

Features

- ▶ Low loss broadband performance
- ▶ High isolation
- ▶ Non-reflective design
- ▶ Integrated 2:4 TTL decoder
- ▶ Pb-free RoHs compliant 4x4 SMT package

Description

The CMD234C4 is a broadband MMIC SP3T switch housed in a leadless 4x4 mm surface mount package. The CMD234C4 covers DC to 18 GHz and offers a low insertion loss of 2 dB and high isolation of 42 dB at 10 GHz. The switch also includes an on board binary decoder circuit which reduces the number of required logic control lines from three to two. The CMD234C4 operates using complementary control voltage logic lines of 0/-5 V and consumes little DC current.

Functional Block Diagram

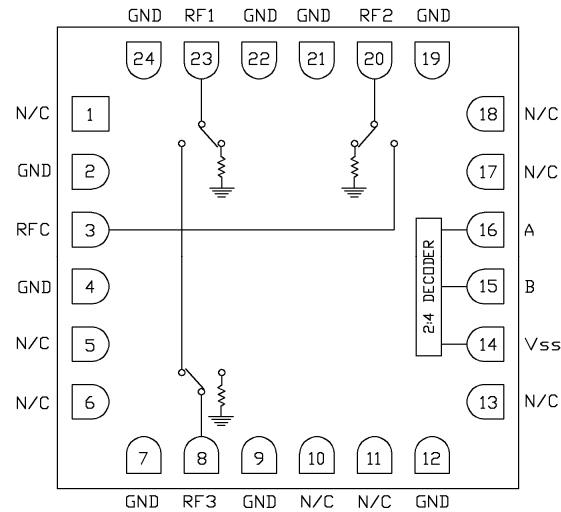

Electrical Performance – $V_{ctl} = 0/-5\text{ V}$, $V_{ss} = -5\text{ V}$, $T_A = 25\text{ }^\circ\text{C}$, $F = 10\text{ GHz}$

Parameter	Min	Typ	Max	Units
Frequency Range	DC – 18			GHz
Insertion Loss		2.0		dB
Isolation		42		dB
Return Loss – On State		12		dB
Return Loss RF1, RF2, RF3 – Off State		8		dB
Input P0.1dB		23		dBm
Switching Speed		66		ns



CMD234C4

DC-18 GHz SP3T Non-reflective Switch

Specifications

Absolute Maximum Ratings

Parameter	Rating
RF Input Power	+27 dBm
Bias Voltage (Vss)	-7 V
Control Voltage Range (A,B)	+0.5 V to -7.5 V
Channel Temperature, T _{ch}	150 °C
Thermal resistance, Θ_{JC}	122.23 °C/W
Operating Temperature	-40 to 85 °C
Storage Temperature	-55 to 150 °C

Operation of this device outside the maximum ratings may cause permanent damage.

Bias Voltage & Current

V _{ss} Range = -5.0V ± 10%		
V _{ss} (V)	I _{ss} (Typ) (mA)	I _{ss} (Max) (mA)
-5	4.5	8.0

TTL/CMOS Control Voltages

State	Bias Condition
Low	-1V to 0V @ 0.5 mA Typ
High	-7V to -3V @ 1 uA Typ

Truth Table

Control Input		Signal Path State
A	B	RFC to:
High	High	RF3
Low	High	RF2
High	Low	RF1
Low	Low	All Off

Electrical Specifications – V_{ctl} = 0/-5 V, V_{ss} = -5 V T_A = 25 °C

Parameter	Min	Typ	Max	Min	Typ	Max	Min	Typ	Max	Units
Frequency Range	DC – 6			DC – 14			DC – 18			GHz
Insertion Loss		2	2.4		2	2.4		3	3.5	dB
Isolation	50	55		35	40		35	40		dB
Return Loss – On State		17			12			12		dB
Return Loss – Off State		9			7			7		dB
Input P _{0.1dB}		18			16			15		dBm
Input IP ₃		38			38			38		dBm
Switching Speed		66			66			66		ns

ver 1.2 1017

Typical Performance

Insertion Loss vs. Temperature

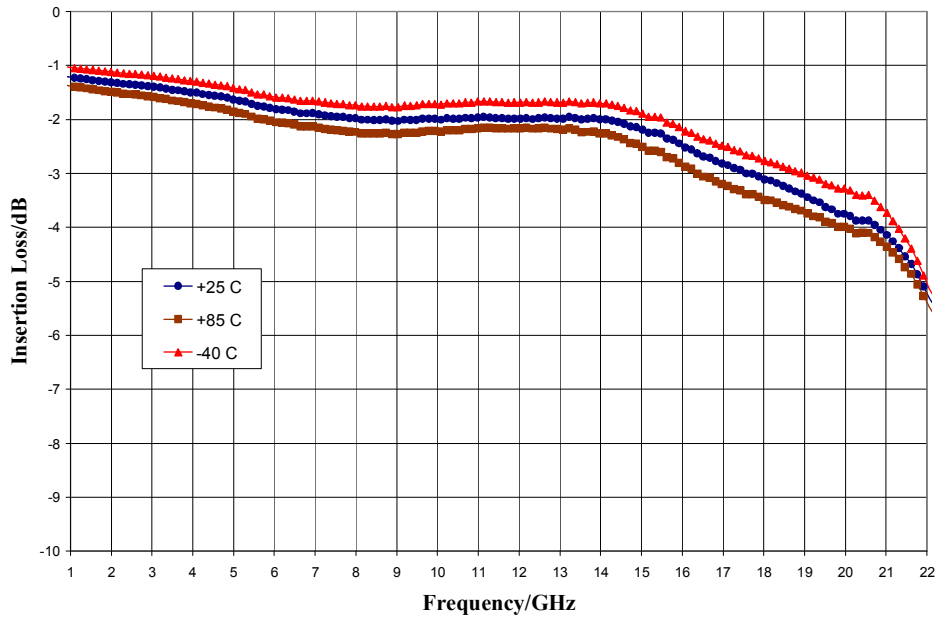

Return Losses

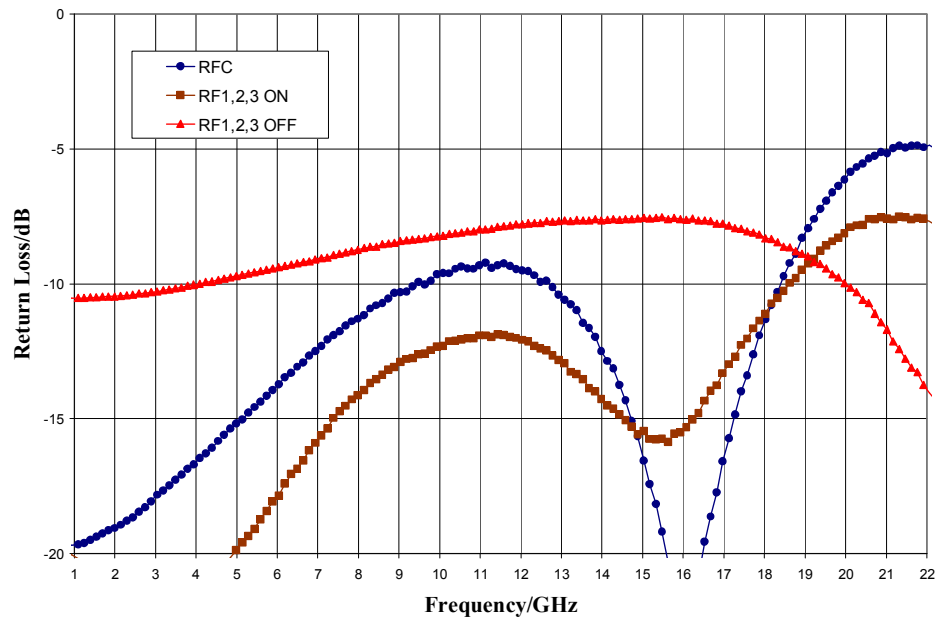

ver 1.2 1017

Typical Performance

Isolation Between Ports RFC and RF1/RF2/RF3

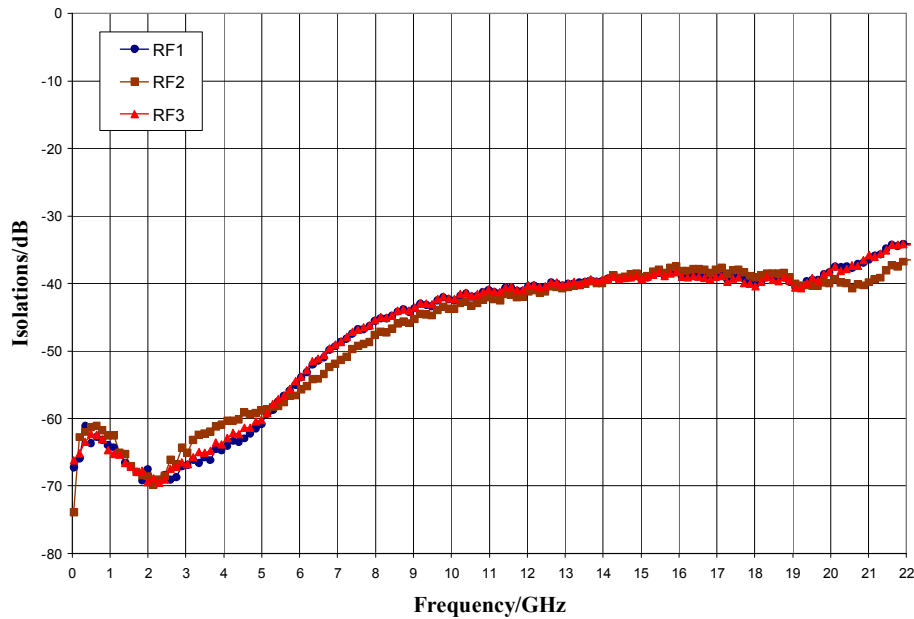

Input P0.1dB Compression Point vs. Temperature

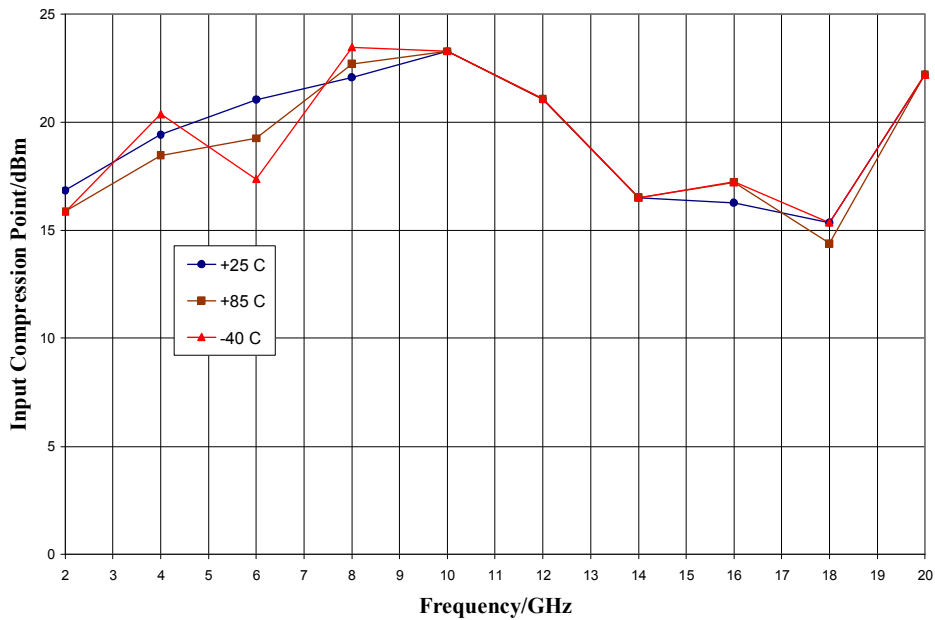

ver 1.2 1017

Typical Performance

Input Third Order Intercept Point vs. Temperature

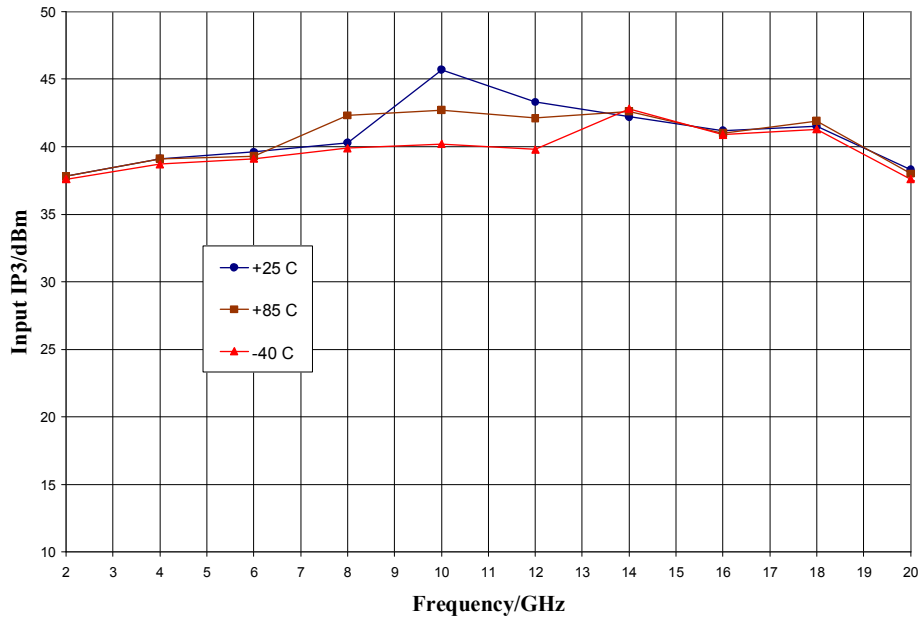

Mechanical Information

Package Information and Dimensions

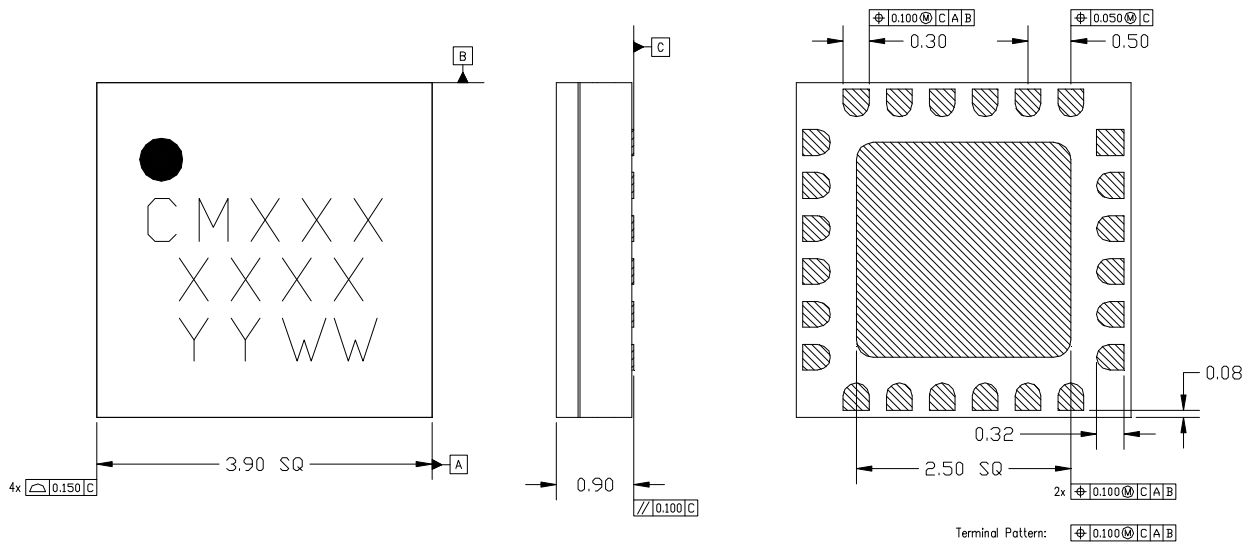

- NOTES:
1. ALL DIMENSIONS SHOWN IN mm.
 2. MATERIAL: BLACK ALUMINA
 3. LEAD FINISH:
 - 3.1. Ni: 8.89um MAX, 1.27um MIN
 - 3.2. Pd: 0.17um MAX, 0.07um MIN
 - 3.3. Au: 0.254um MAX, 0.03um MIN
 4. MARKING
 - 4.1. LINE 1: PART NUMBER
 - 4.1.1. EXAMPLE: CMD191C4 SHALL BE MARKED AS CM191
 - 4.2. LINE 2: LOT NUMBER
 - 4.3. LINE 3: DATE CODE - LAST 2 DIGITS OF THE YEAR OF MANUFACTURE FOLLOWED BY A 2 DIGIT WEEK CODE
 5. ALTERNATE PIN #1 IDENTIFIER IS A SINGLE SQUARE PAD
 6. ALTERNATE DIE PADDLE MAY HAVE CHAMFERED CORNERS

Recommended PCB Land Pattern

Custom MMIC Design Services recommends that the user develop the land pattern that will provide the best design for proper solder reflow and device attach for their specific application. Please review Custom MMIC Application Note AN 105 for a recommended land pattern approach.

Recommended Solder Reflow Profile

Custom MMIC Design Services recommends screen printing with belt furnace reflow to ensure proper solder reflow and device attach. Please review Custom MMIC Application Note AN 102 for a recommended solder reflow profile.

Pin Description

Pin Diagram

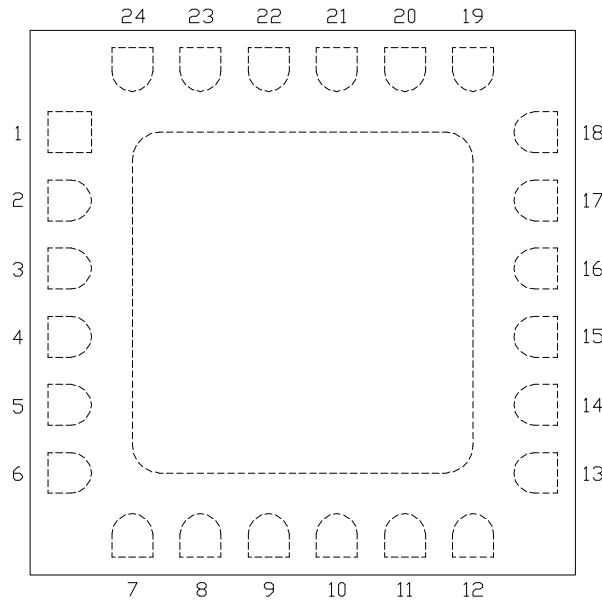

Functional Description

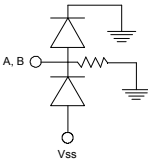
Pin	Function	Description	Schematic
1,5,6,10,11,13,17,18	N/C	No connection required. These pins may be connected to RF/DC ground	
2,4,7,9,12,19,21,22,24 and die paddle	Ground	Connect to RF / DC ground	
3,8,20,23	RFC, RF3, RF2, RF1	These pins are DC coupled and matched to 50 Ohm. Blocking capacitors are required if RF line potential is not equal to 0V	
14	Vss	Power supply voltage	
15	CTLB	See truth table and control voltage table	
16	CTLA	See truth table and control voltage table	

ver 1.2 1017