

### Features

- ▶ Low conversion loss
- ▶ High isolation
- ▶ Wide IF bandwidth
- ▶ Passive double balanced topology
- ▶ Pb-free RoHs compliant 3x3 mm SMT package

### Description

The CMD251C3 is a general purpose double balanced mixer in a leadless surface mount package that can be used for up- and downconverting applications between 4 and 8.5 GHz. The CMD251C3 has very high isolation to both the RF and IF ports due to the optimized balun structures, and can operate with an LO drive level as low as +15 dBm. The CMD251C3 can easily be configured as an image reject mixer or single sideband modulator with external hybrids and power splitters.

### Functional Block Diagram

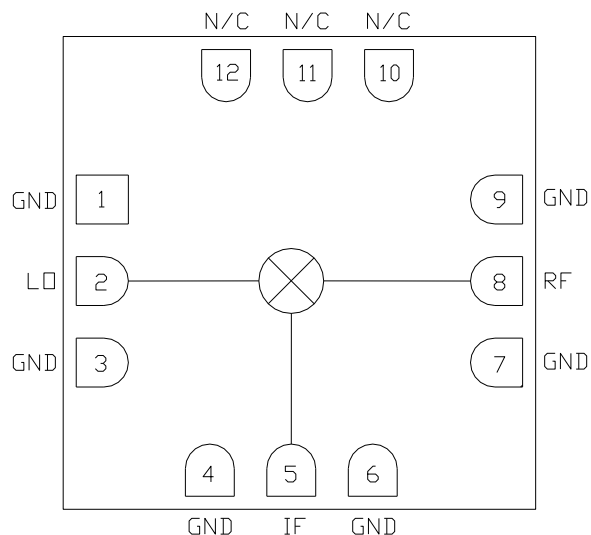

### Electrical Performance – IF = 100 MHz, LO = +17 dBm, $T_A = 25^\circ\text{C}$ , F = 6 GHz

Parameter	Min	Typ	Max	Units
Frequency Range, RF & LO	4 – 8.5			GHz
Frequency Range, IF	DC		2.2	GHz
Conversion Loss		7		dB
LO to RF Isolation		45		dB
LO to IF Isolation		36		dB
RF to IF Isolation		25		dB
Input IP3		21		dBm

Unless otherwise noted, all measurements performed as a downconverter, IF = 100 MHz

### Specifications

#### Absolute Maximum Ratings

Parameter	Rating
RF / IF Input Power	+25 dBm
LO Drive	+25 dBm
Operating Temperature	-40 to 85 °C
Storage Temperature	-55 to 150 °C
Thermal resistance, $\Theta_{JC}$	280.4 °C/ W

Operation of this device outside the maximum ratings may cause permanent damage.

#### Electrical Specifications – IF = 100 MHz, LO = +17 dBm, T<sub>A</sub> = 25 °C

Parameter	Min	Typ	Max	Min	Typ	Max	Units
Frequency Range, RF & LO	4 – 7			7 – 8.5			GHz
Frequency Range, IF	DC		2.2	DC		2.2	GHz
Conversion Loss		7	8.5		8.5	10	dB
Noise Figure (SSB)		7	8.5		8.5	10	dB
LO to RF Isolation	40	45		40	45		dB
LO to IF Isolation	30	40		42	50		dB
RF to IF Isolation	15	25		30	35		dB
Input P1dB		16			17		dBm
Input IP3		22			25		dBm

Unless otherwise noted, all measurements performed as a downconverter, IF = 100 MHz

ver 1.0 0717

### Typical Performance

Conversion Gain vs. Temperature, LO = +17 dBm, IF = 100 MHz USB

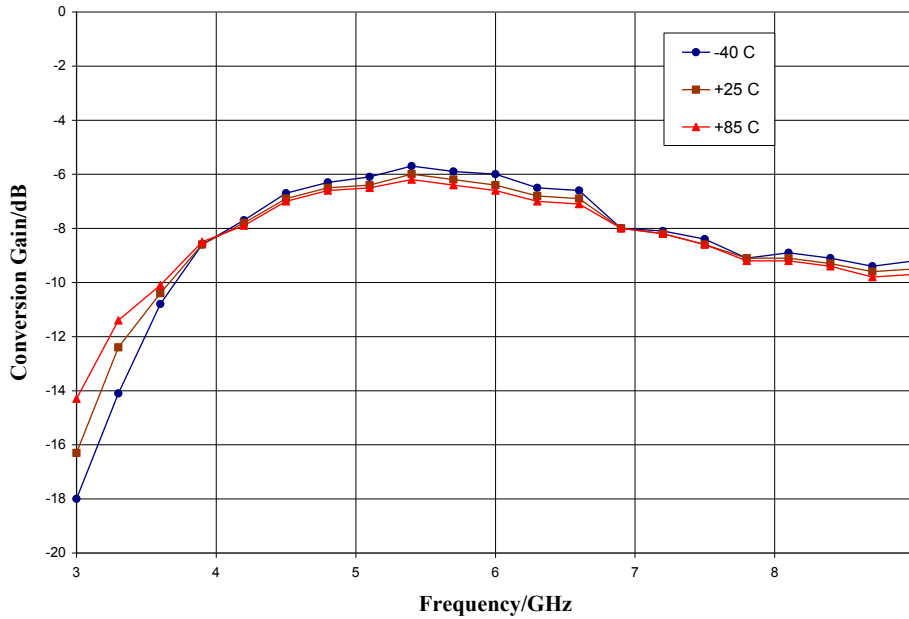

Isolations, LO = +17 dBm

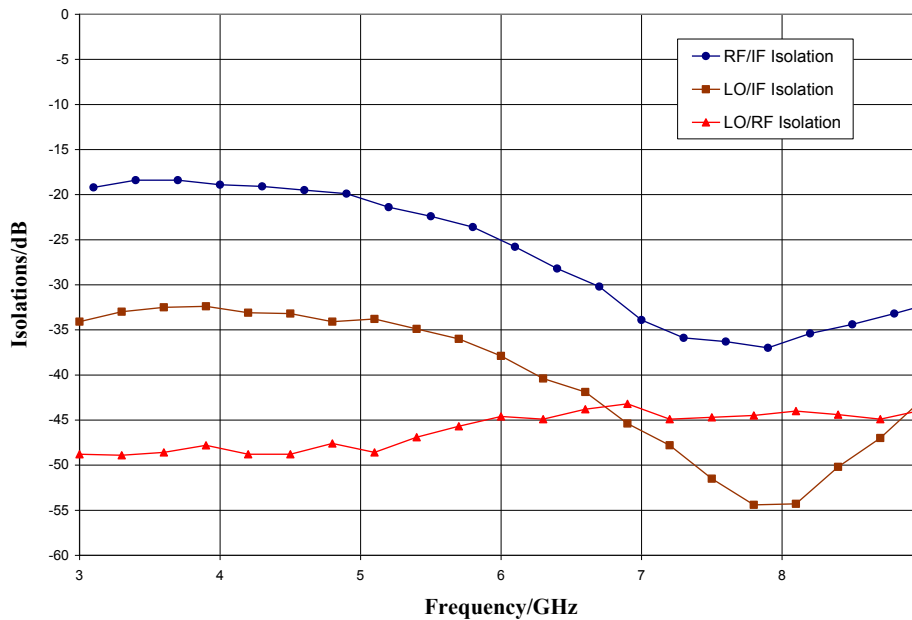

ver 1.0 0717

### Typical Performance

#### Conversion Gain vs. LO Drive, IF = 100 MHz USB

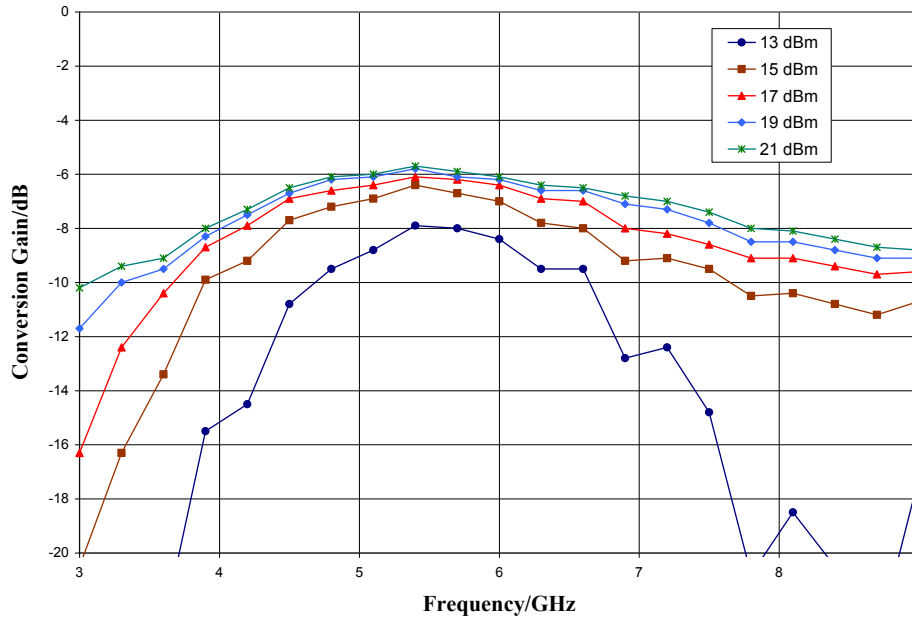

#### Return Loss, LO = +17 dBm

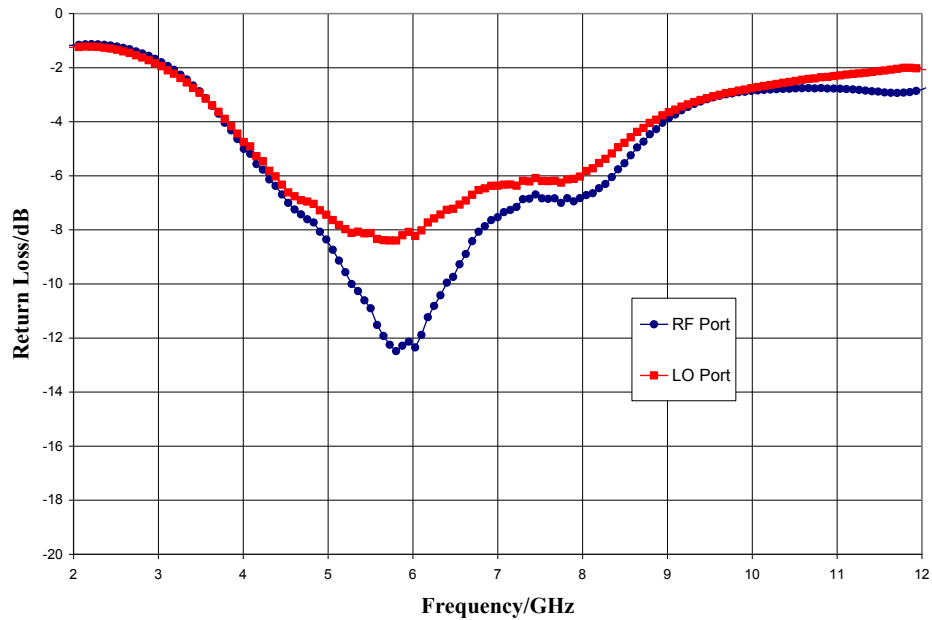

ver 1.0 0717

### Typical Performance

IF Bandwidth, LO = +17 dBm

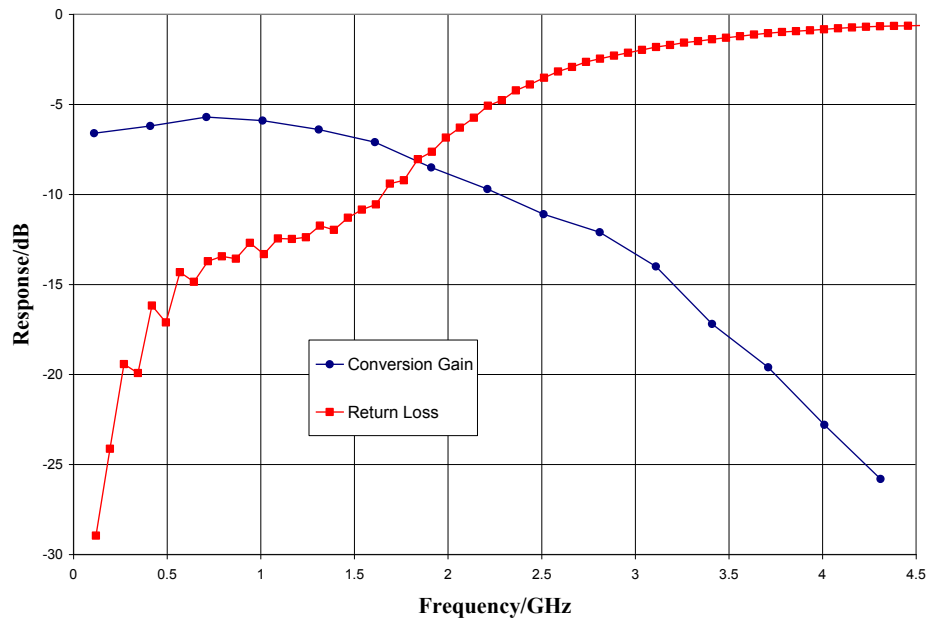

Upconverter Performance, Conversion Gain vs. LO Drive, IF input = 100 MHz

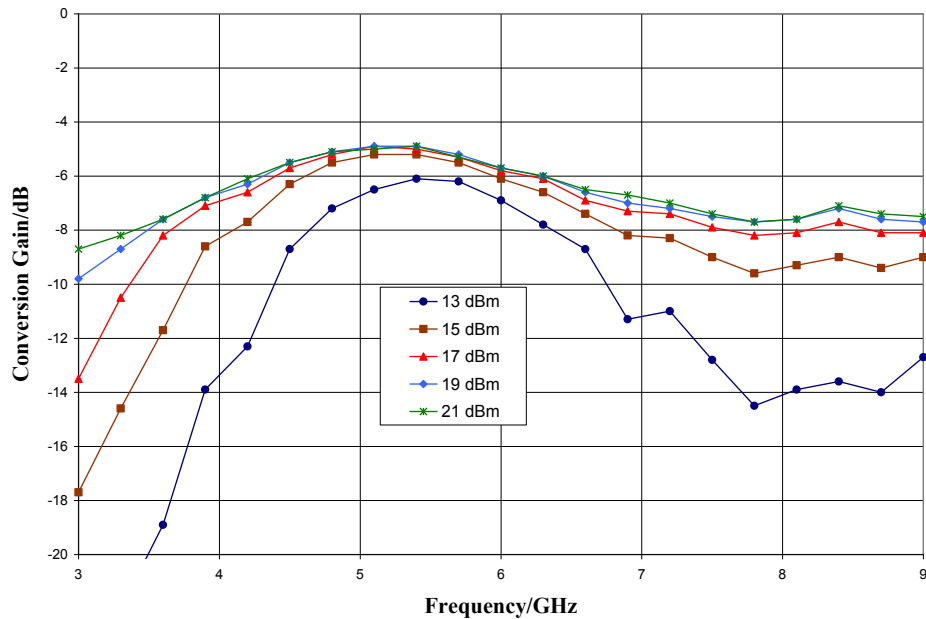

ver 1.0 0717

### Typical Performance

**Input IP3 vs. Temperature, LO = +17 dBm, IF = 100 MHz**

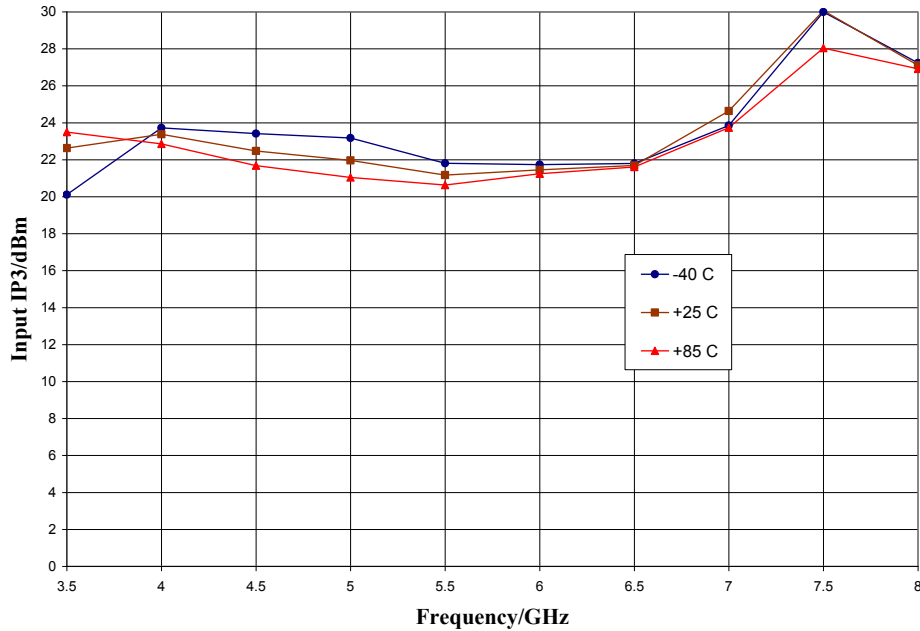

**Input IP3 vs. LO Drive, IF = 100 MHz**

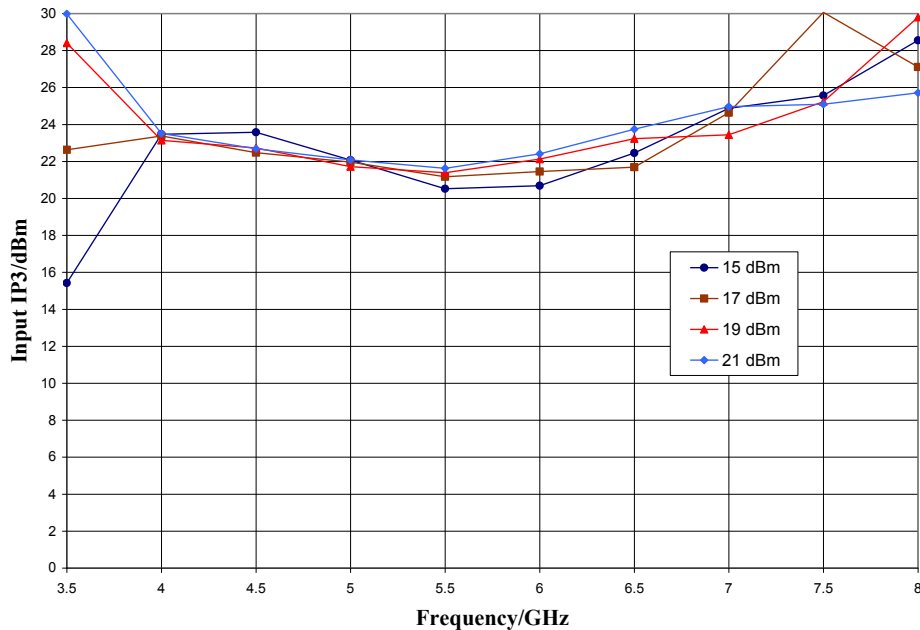

ver 1.0 0717

### Typical Performance

#### Upconverter Performance, Input IP3 vs. LO Drive, IF = 100 MHz

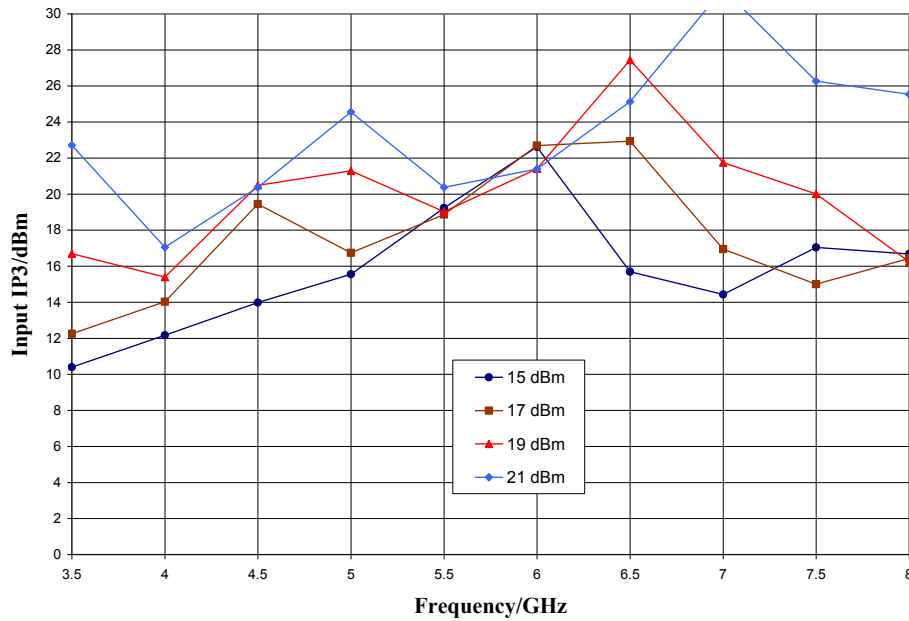

#### Input P1dB vs. Temperature, LO = +17 dBm, IF = 100 MHz USB

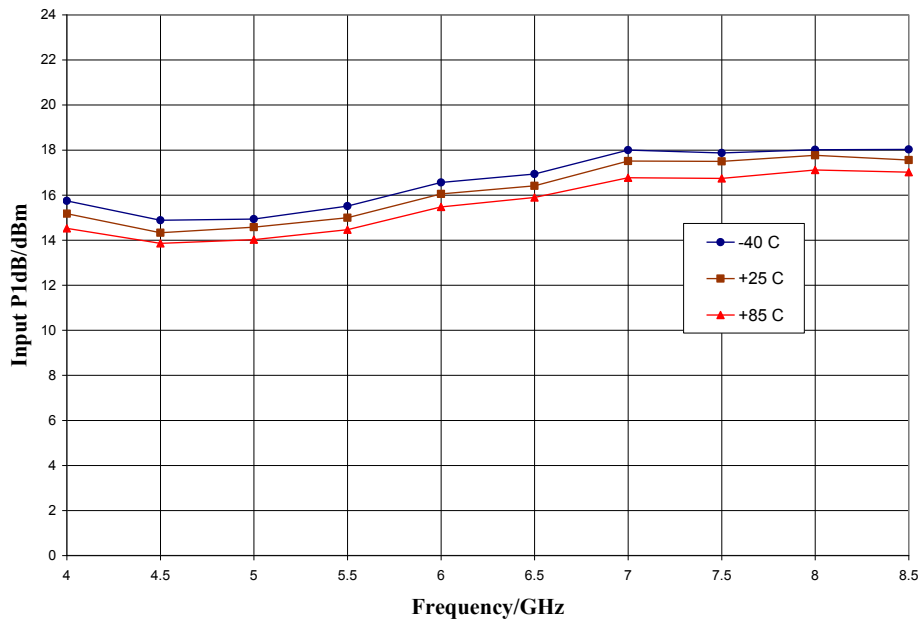

ver 1.0 0717

### Typical Performance

#### MxN Spurious Outputs

mRF	nLO				
	0	1	2	3	4
0	xx	7	9	22	35
1	21	0	35	36	39
2	67	> 80	70	71	68
3	> 80	> 80	> 80	> 80	> 80
4	> 80	> 80	> 80	> 80	> 80

RF = 6.1 GHz @ -10 dBm  
 LO = 6.0 GHz @ +17 dBm  
 All values in dBc below the IF output power level (1RF - 1LO)





### Pin Description

#### Pin Diagram

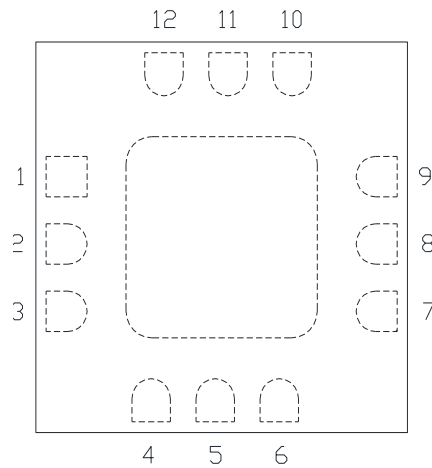

#### Functional Description

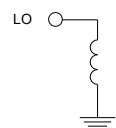
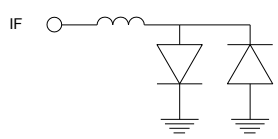
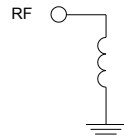
Pin	Function	Description	Schematic
1,3,4,6,7,9 and die paddle	Ground	Connect to RF / DC ground.	
2	LO	This pin is DC coupled and matched to 50 ohms.	
5	IF	This pin is DC coupled. For applications not requiring operation to DC, this port should be DC blocked externally using a series capacitor whose value has been chosen to pass the necessary IF frequency range. For operation to DC, this pin must not source or sink more than 16 mA of current or part non-function or part failure may result.	
8	RF	This pin is DC coupled and matched to 50 ohms.	
10-12	N/C	No connection required. These pins may be connected to RF/DC ground	

ver 1.0 0717