

### Product Overview

The CMD263P3 is a broadband MMIC low noise amplifier housed in a leadless 3x3 mm plastic surface mount QFN package. The CMD263P3 is ideally suited for microwave radios and C and X-band applications where small size and low power consumption are needed. The broadband device delivers greater than 22 dB of gain with a corresponding output 1 dB compression point of +11 dBm and a noise figure of 1.4 dB. The CMD263P3 is a 50 ohm matched design eliminating the need for external DC blocks and RF port matching.

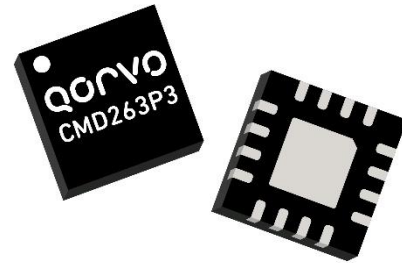

### Functional Block Diagram

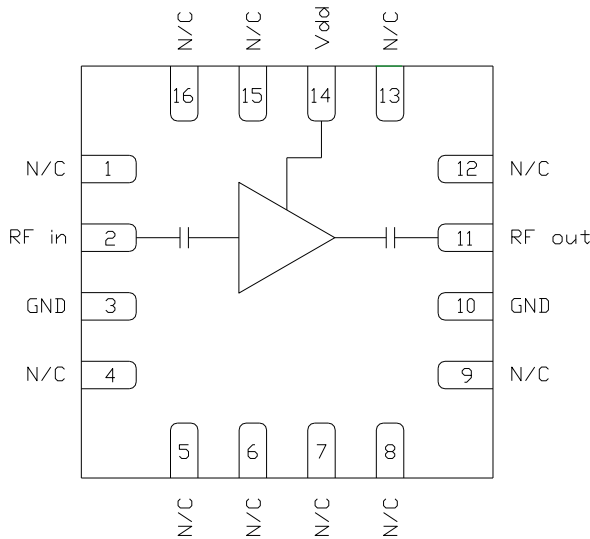

### Key Features

- Ultra Low Noise Figure
- Low Current Consumption
- High Gain Broadband Performance
- Single Supply Voltage: +3.6 V @ 32 mA
- Pb-Free RoHs Compliant 3x3 QFN Package

### Ordering Information

Part No.	Description
CMD263P3	100 pcs on 7" reel

### Electrical Performance ( $V_{dd} = 3.6\text{ V}$ , $T_A = 25^\circ\text{C}$ , $F = 8\text{ GHz}$ )

Parameter	Min	Typ	Max	Units
Frequency Range		5 - 11		GHz
Gain		22		dB
Noise Figure		1.4		dB
Input Return Loss		17		dB
Output Return Loss		13		dB
Output P1dB		11		dBm
Supply Current		32		mA

## Absolute Maximum Ratings

Parameter	Rating
Drain Voltage, $V_{dd}$	5.0 V
RF Input Power	+20 dBm
Channel Temperature, $T_{ch}$	150°C
Power Dissipation, $P_{diss}$	367 mW
Thermal Resistance, $Q_{JC}$	177° C/W
Operating Temperature	-40 to 85°C
Storage Temperature	-55 to 150°C

Exceeding any one or combination of the maximum ratings may cause permanent damage to the device.

## Recommended Operating Conditions

Parameter	Min	Typ	Max	Units
$V_{dd}$	2.0	3.6	4.5	V
$I_{dd}$		32		mA

Electrical performance is measured at specific test conditions. Electrical specifications are not guaranteed over all recommended operating conditions.

## Electrical Specifications ( $V_{dd} = 3.6$ V, $T_A = 25^\circ$ C)

Parameter	Min	Typ	Max	Min	Typ	Max	Units
Frequency Range		5 - 8.5			8.5 - 11		GHz
Gain	19	22	26	19	22	26	dB
Noise Figure		1.6	2.4		1.3	1.7	dB
Input Return Loss		10			10		dB
Output Return Loss		13			12		dB
Output P1dB		11			11.5		dBm
Output IP3		21			21		dBm
Supply Current	22	32	42	22	32	42	mA
Gain Temperature Coefficient		0.013			0.013		dB/°C
Noise Figure Temperature Coefficient		0.008			0.008		dB/°C

Typical Performance

Broadband Performance,  $V_{dd} = 3.6\text{ V}$ ,  $I_{dd} = 32\text{ mA}$ ,  $T_A = 25^\circ\text{ C}$

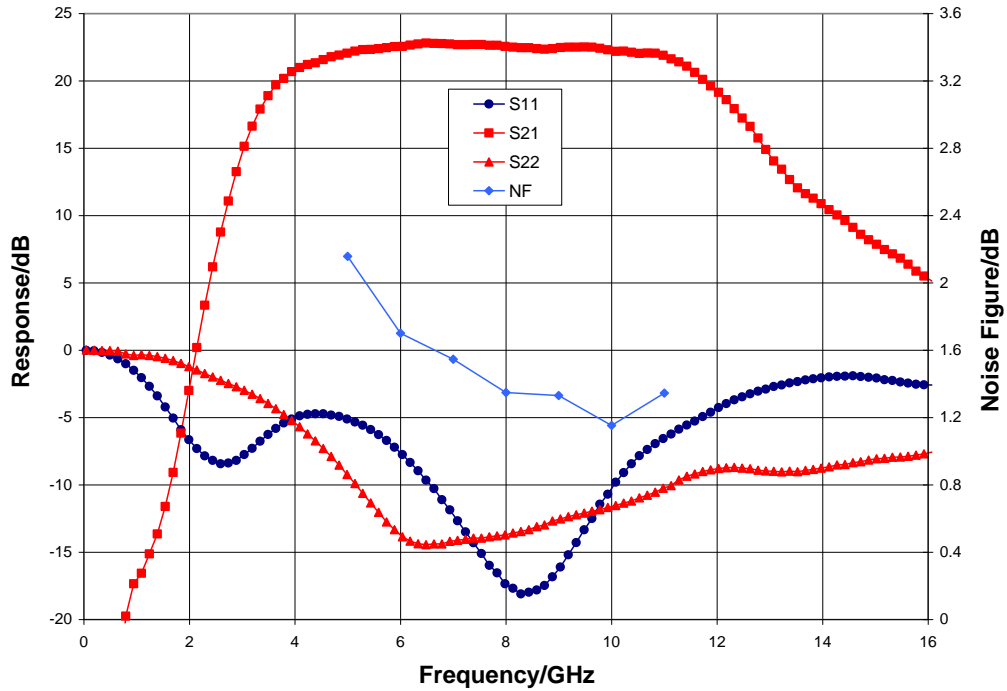

Narrow-band Performance,  $V_{dd} = 3.6\text{ V}$ ,  $I_{dd} = 32\text{ mA}$ ,  $T_A = 25^\circ\text{ C}$

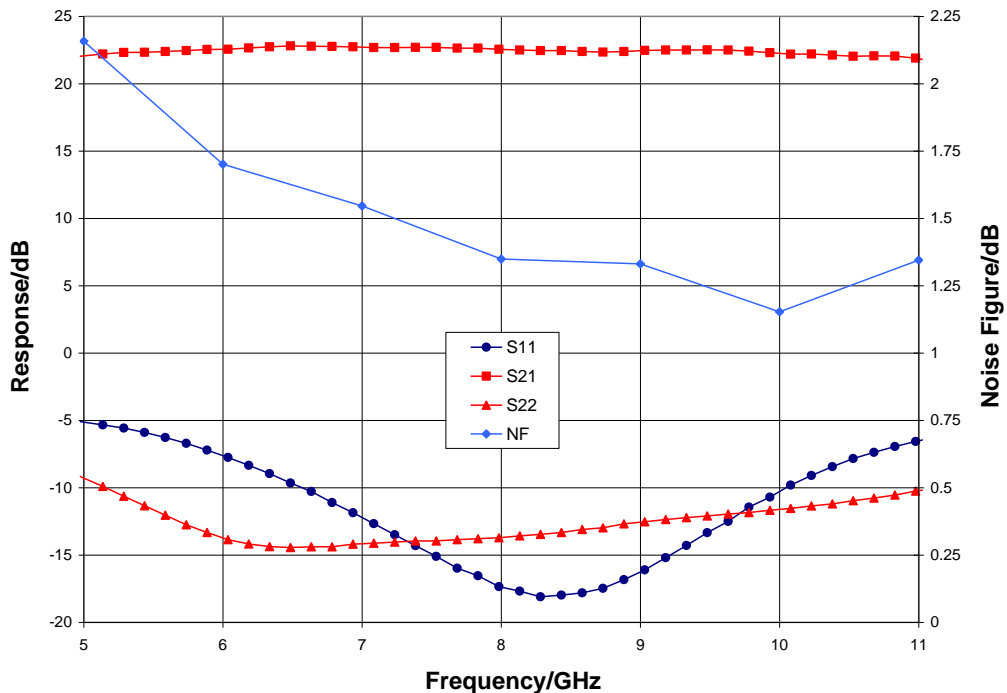

Typical Performance

Gain vs. Temperature,  $V_{dd} = 3.6\text{ V}$

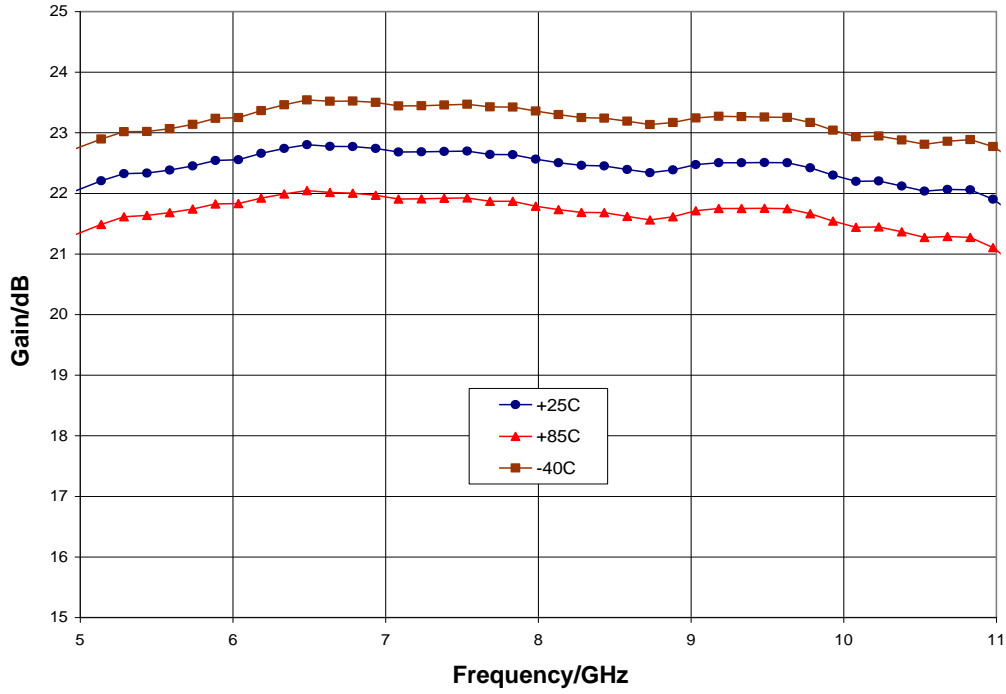

Noise Figure vs. Temperature,  $V_{dd} = 3.6\text{ V}$

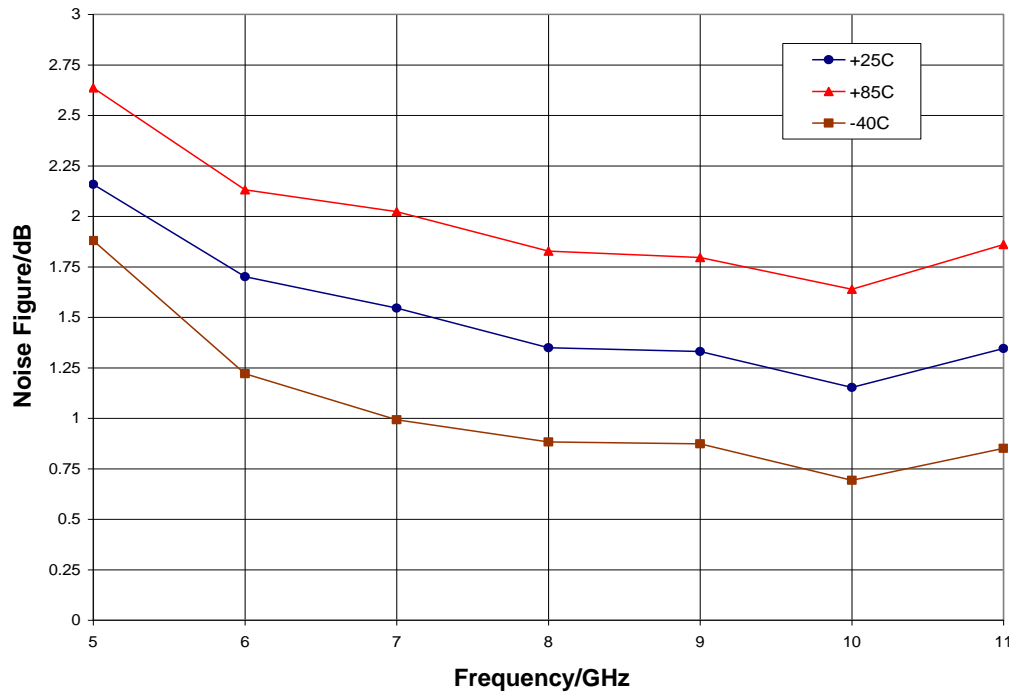

Typical Performance

Output Power,  $V_{dd} = 3.6\text{ V}$ ,  $I_{dd} = 32\text{ mA}$ ,  $T_A = 25^\circ\text{ C}$

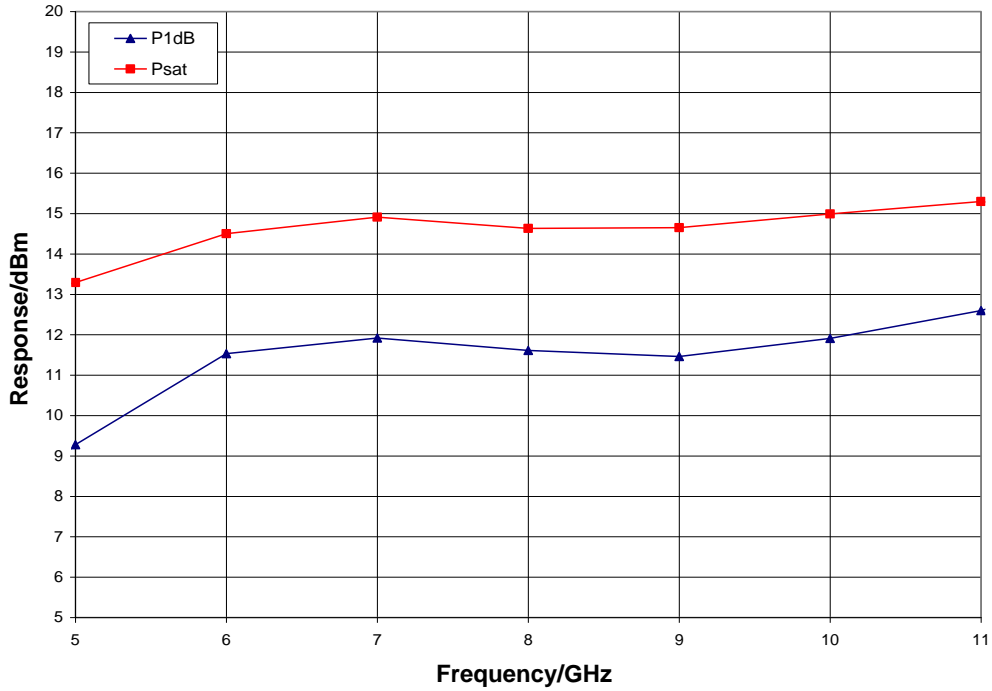

Output P1dB vs. Temperature,  $V_{dd} = 3.6\text{ V}$ ,  $T_A = 25^\circ\text{ C}$

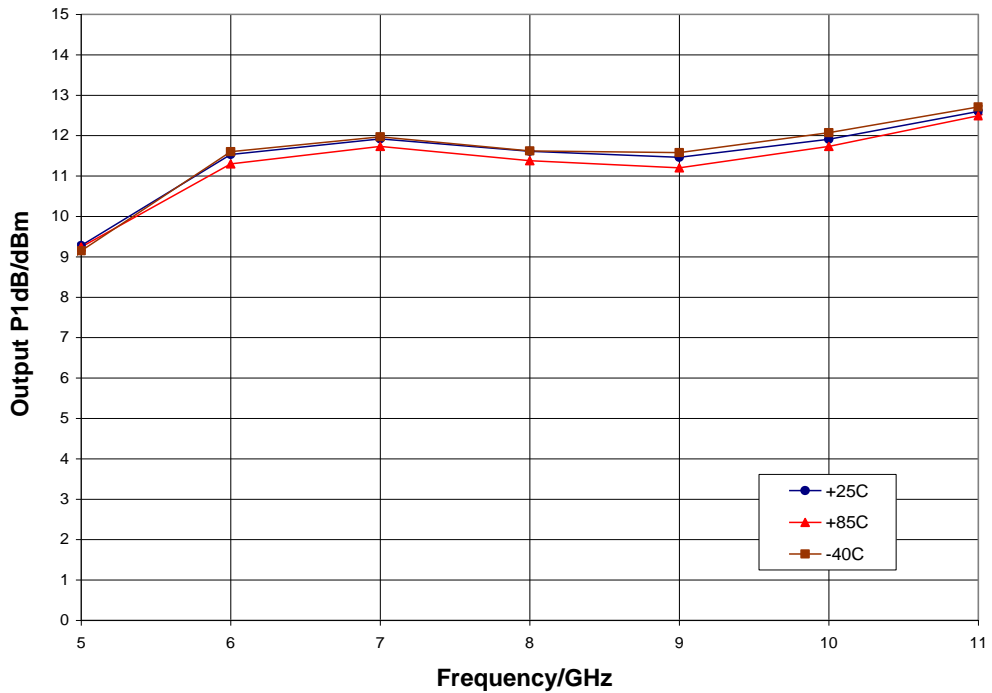

Typical Performance

Output IP3 vs. Temperature,  $V_{dd} = 3.6\text{ V}$ ,  $T_A = 25^\circ\text{C}$

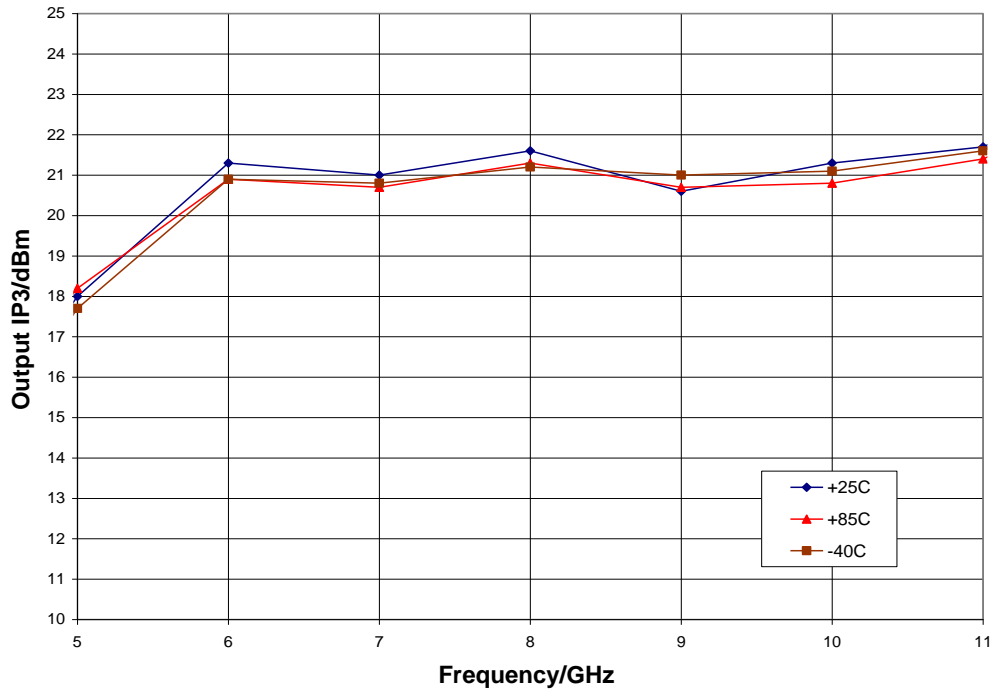

## Mechanical Information

### Package Information and Dimensions

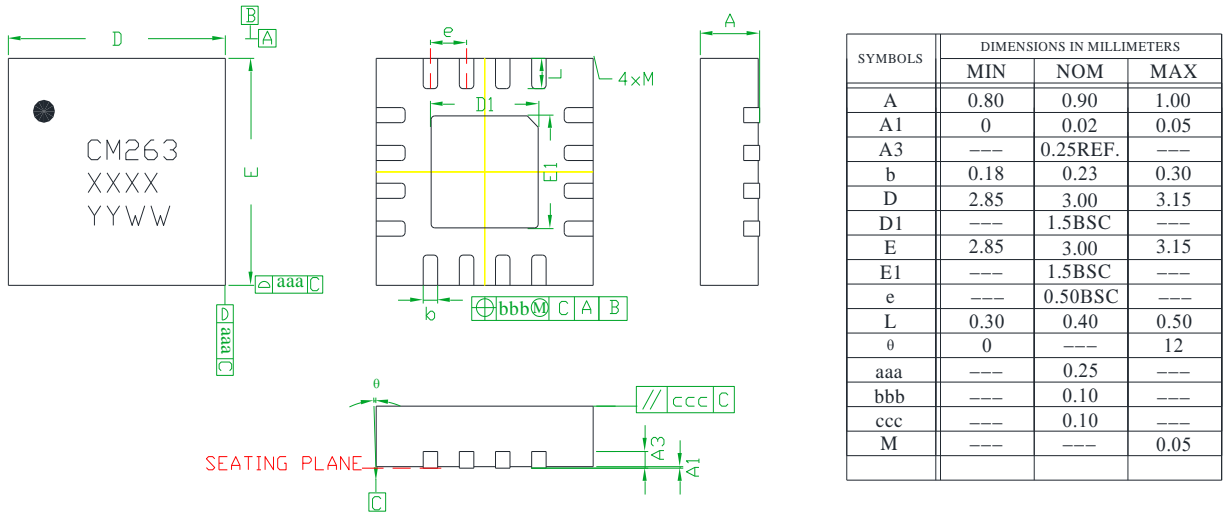

**Notes:**

1. Dimensions are in millimeters
2. RoHS compliant mold compound
3. Lead frame material: Copper alloy
4. Lead finish: Electroless nickel electroless palladium
5. Immersion gold (ENEPIG) plating in accordance with IPC - 4556
6. Indicated dimension/tolerance applies to leads and exposed pads

### Recommended PCB Land Pattern

Qorvo recommends that the user develop the land pattern that will provide the best design for proper solder reflow and device attach for their specific application. Please review Qorvo Application Note AN 105 for a recommended land pattern approach.

### Recommended Solder Reflow Profile

Qorvo recommends screen printing with belt furnace reflow to ensure proper solder reflow and device attach. Please review Qorvo Application Note AN 102 for a recommended solder reflow profile.

## Pin Description

### Pin Diagram

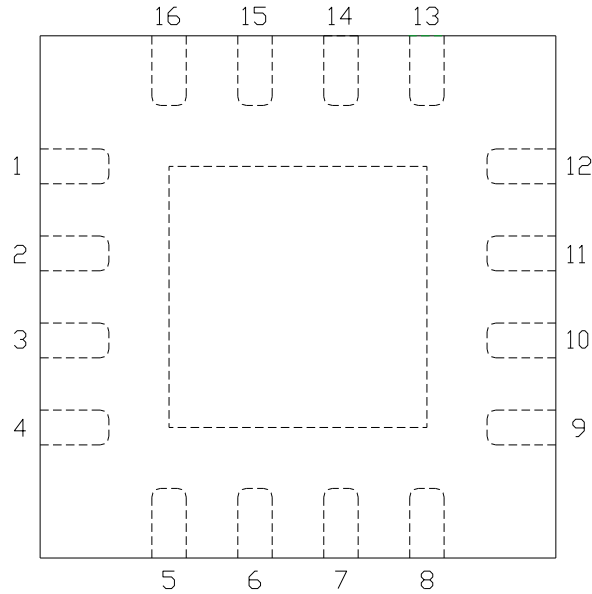

### Functional Description

Pin	Function	Description	Schematic
1, 4 - 9, 12, 13, 15, 16	N/C	No connection required These pins may be connected to RF / DC ground	
2	RF in	DC blocked and 50 ohm matched	
3, 10, and die paddle	Ground	Connect to RF / DC ground	
11	RF out	DC blocked and 50 ohm matched	
14	V <sub>dd</sub>	Power supply voltage Decoupling and bypass caps required	



**Applications Information**

**Application Circuit**

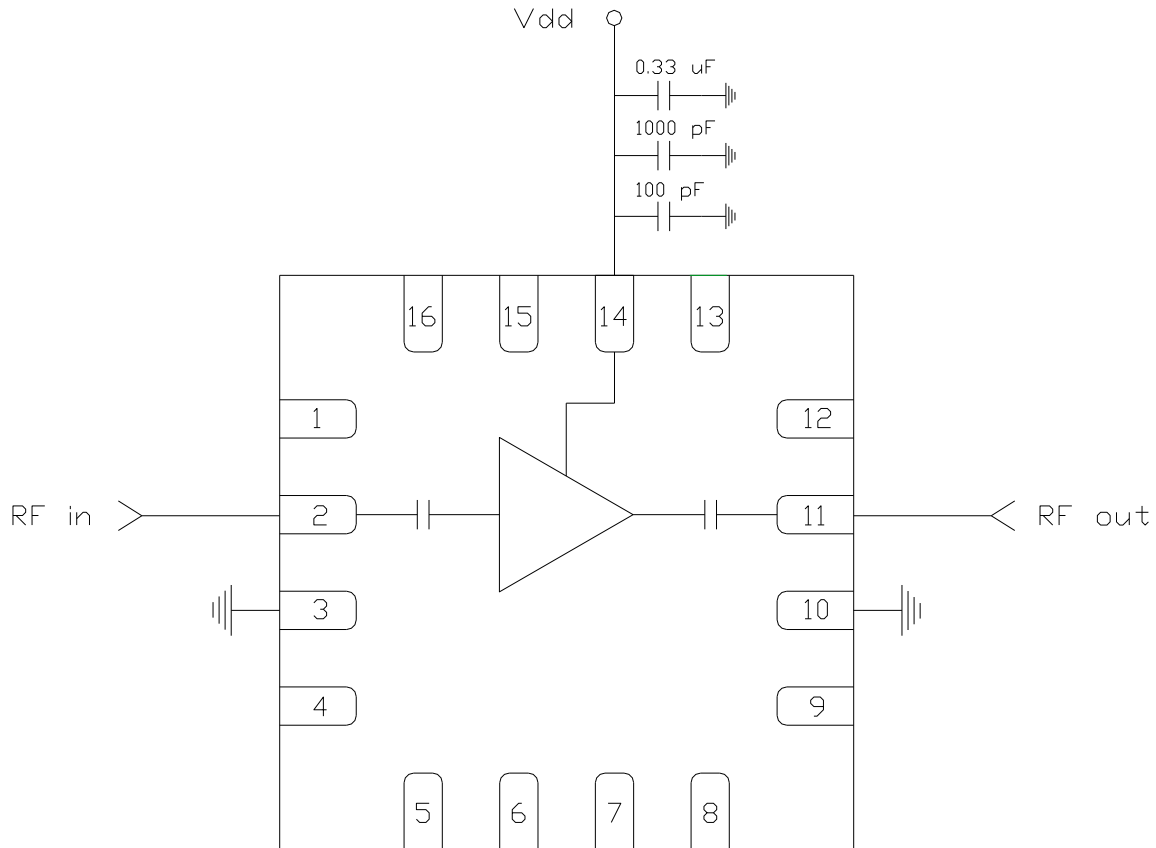

**Biasing and Operation**

The CMD263P3 is biased with a single positive drain supply. Performance is optimized when the drain voltage is set to +3.6 V, though it may be set to a minimum of +2.0 V and a maximum of +4.5 V.

RF power can be applied at any time.

**GaAs MMIC devices are susceptible to damage from Electrostatic Discharge. Proper precautions should be observed during handling, assembly and test.**

## Applications Information

### Evaluation Board

The circuit board shown has been developed for optimized assembly at Qorvo. A sufficient number of via holes should be used to connect the top and bottom ground planes. As surface mount processes vary, careful process development is recommended.

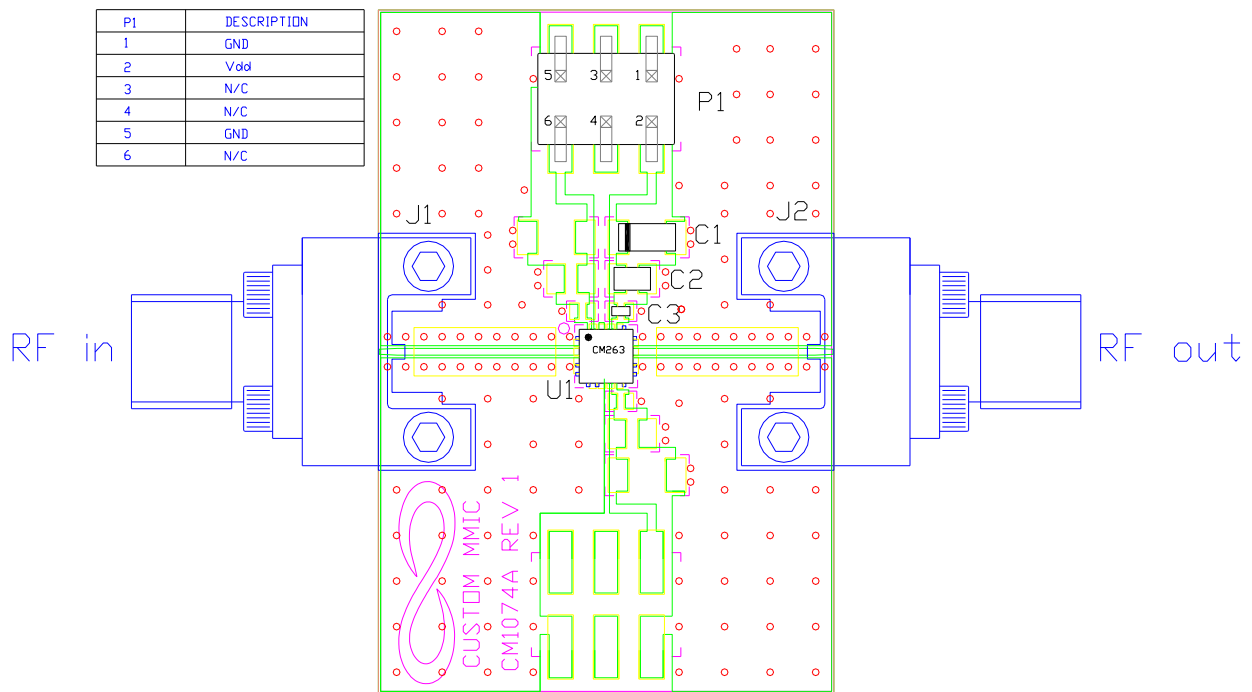

## Bill of Material

Designator	Value	Description
J1, J2		SMA End Launch Connector
P1		6 Pin Header
C1	0.33 $\mu$ F	Capacitor, Tantalum
C2	1000 pF	Capacitor, 0603
C3	100 pF	Capacitor, 0402
U1		CMD263P3 Low Noise Amplifier
PCB		CM1074A Evaluation PCB