

### Product Overview

The CMD264P3 is a broadband MMIC low noise amplifier housed in a leadless 3x3 mm plastic surface mount package. The CMD264P3 is ideally suited for EW and communications systems where small size and low power consumption are needed. The broadband device delivers greater than 26 dB of gain with a corresponding output 1 dB compression point of +12 dBm and a noise figure of 1.6 dB at 10 GHz. The CMD264P3 is a 50 ohm matched design eliminating the need for external DC blocks and RF port matching.

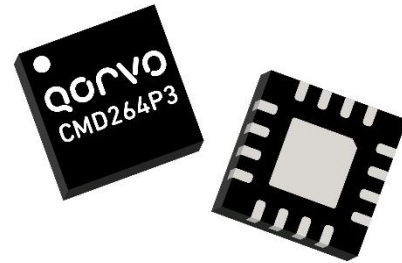

### Functional Block Diagram

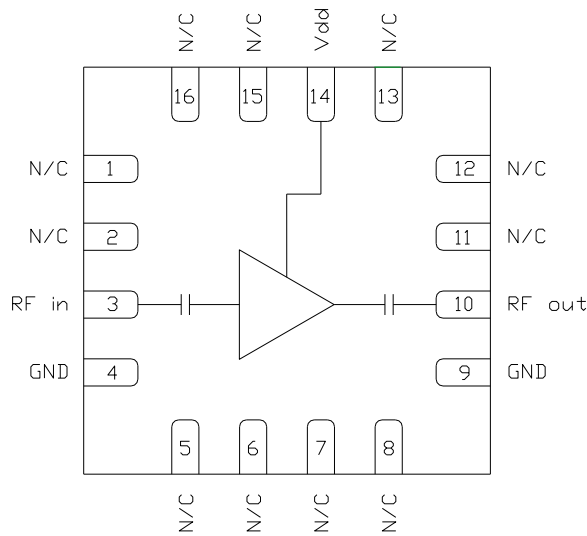

### Key Features

- Ultra Low Noise Figure
- High Gain Broadband Performance
- Single Supply Voltage: +3.0 V @ 63 mA
- Pb-Free RoHs Compliant 3x3 QFN Package

### Ordering Information

Part No.	Description
CMD264P3	100 pcs on 7" reel

### Electrical Performance ( $V_{dd} = 3.0\text{ V}$ , $T_A = 25^\circ\text{C}$ , $F = 10\text{ GHz}$ )

Parameter	Min	Typ	Max	Units
Frequency Range		6 - 18		GHz
Gain		26.5		dB
Noise Figure		1.6		dB
Input Return Loss		13		dB
Output Return Loss		16		dB
Output P1dB		12		dBm
Supply Current		63		mA

## Absolute Maximum Ratings

Parameter	Rating
Drain Voltage, $V_{dd}$	5.0 V
RF Input Power	+20 dBm
Channel Temperature, $T_{ch}$	150°C
Power Dissipation, $P_{diss}$	540 mW
Thermal Resistance, $Q_{JC}$	120°C/W
Operating Temperature	-40 to 85°C
Storage Temperature	-55 to 150°C

Exceeding any one or combination of the maximum ratings may cause permanent damage to the device.

## Recommended Operating Conditions

Parameter	Min	Typ	Max	Units
$V_{dd}$	2.0	3.0	4.5	V
$I_{dd}$		63		mA

Electrical performance is measured at specific test conditions. Electrical specifications are not guaranteed over all recommended operating conditions.

## Electrical Specifications ( $V_{dd} = 3.0$ V, $T_A = 25^\circ\text{C}$ )

Parameter	Min	Typ	Max	Min	Typ	Max	Units
Frequency Range		6 - 9			9 - 18		GHz
Gain	24	27	30	18	25	30	dB
Noise Figure		1.7	2.4		1.8	2.5	dB
Input Return Loss		18			10		dB
Output Return Loss		15			18		dB
Output P1dB		13			12		dBm
Output IP3		24			22		dBm
Supply Current	43	63	83	43	63	83	mA
Gain Temperature Coefficient		0.018			0.018		dB/°C
Noise Figure Temperature Coefficient		0.008			0.008		dB/°C

Typical Performance

Broadband Performance,  $V_{dd} = 3.0\text{ V}$ ,  $I_{dd} = 63\text{ mA}$ ,  $T_A = 25^\circ\text{ C}$

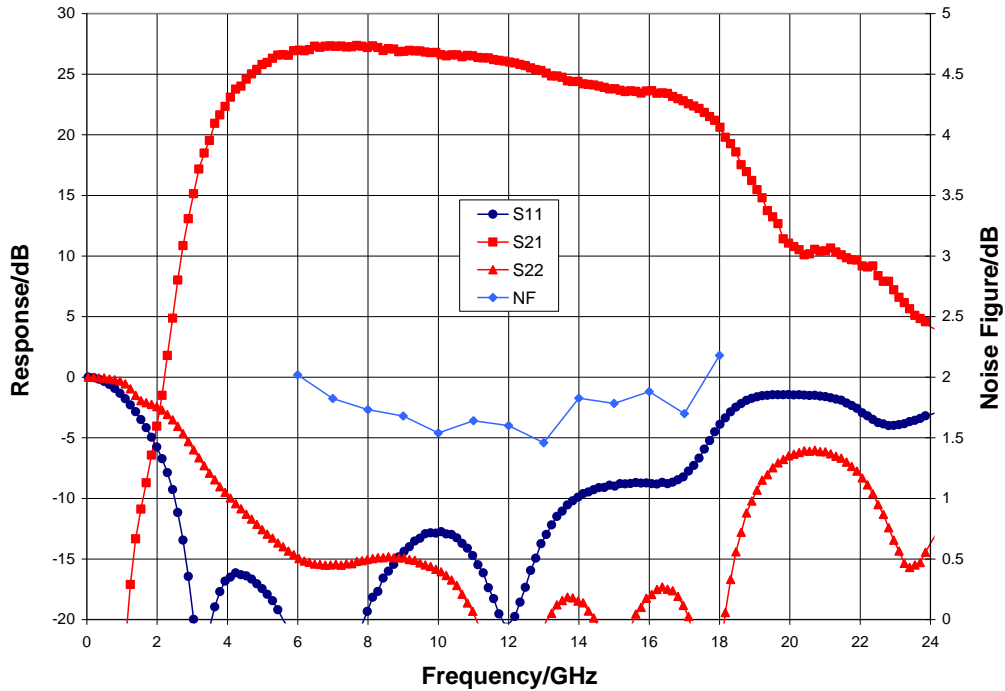

Narrow-band Performance,  $V_{dd} = 3.0\text{ V}$ ,  $I_{dd} = 63\text{ mA}$ ,  $T_A = 25^\circ\text{ C}$

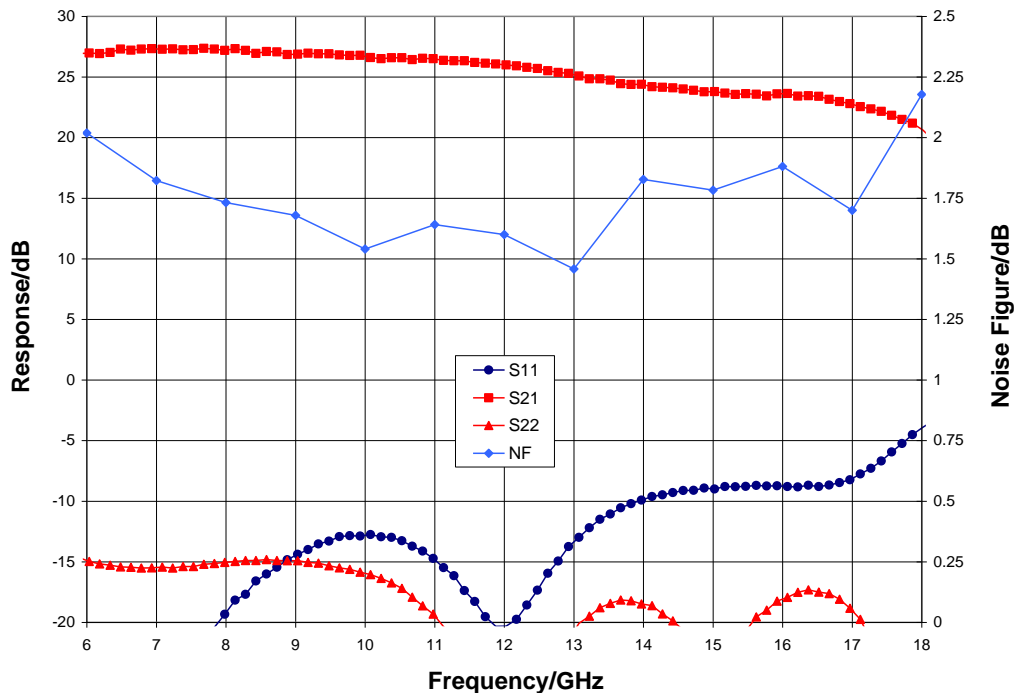

Typical Performance

Gain vs. Temperature,  $V_{dd} = 3.0\text{ V}$

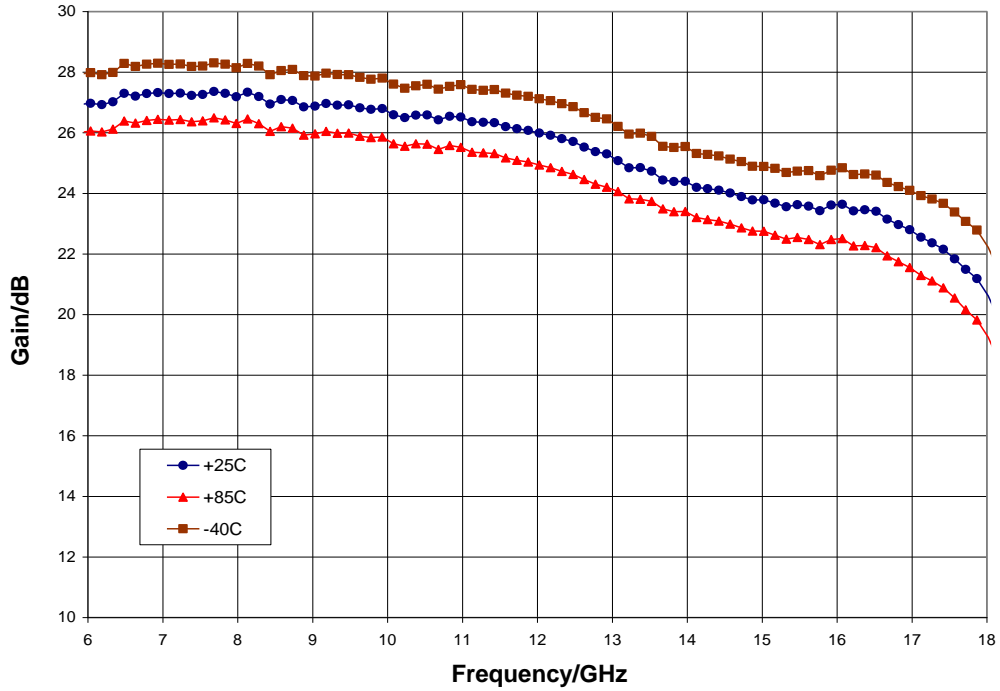

Noise Figure vs. Temperature,  $V_{dd} = 3.0\text{ V}$

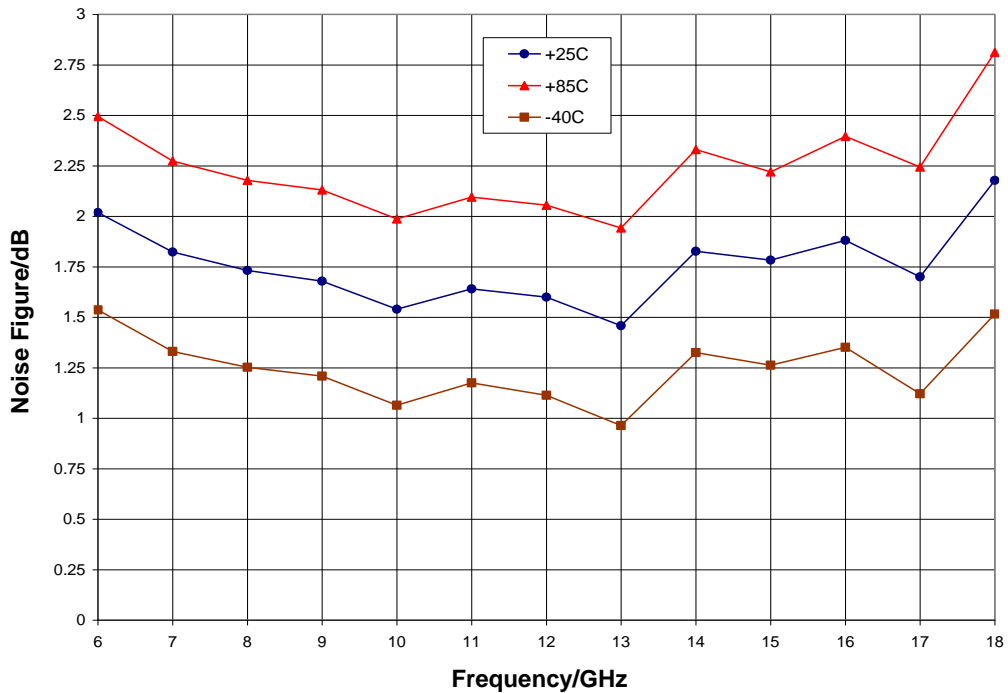

Typical Performance

Output Power,  $V_{dd} = 3.0\text{ V}$ ,  $I_{dd} = 63\text{ mA}$ ,  $T_A = 25^\circ\text{ C}$

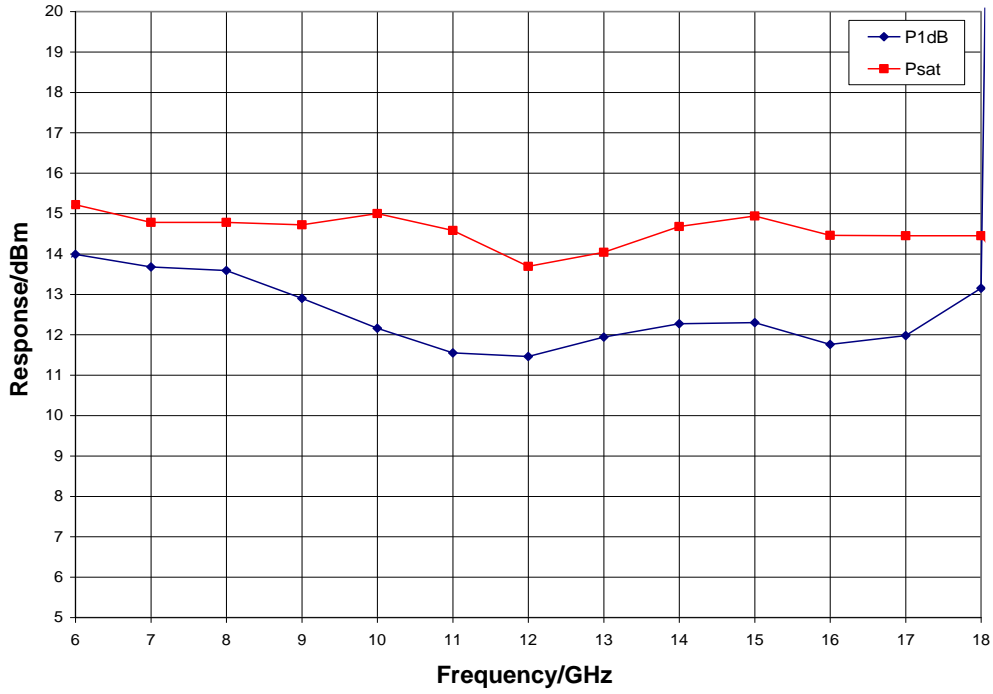

Output P1dB vs. Temperature,  $V_{dd} = 3.0\text{ V}$

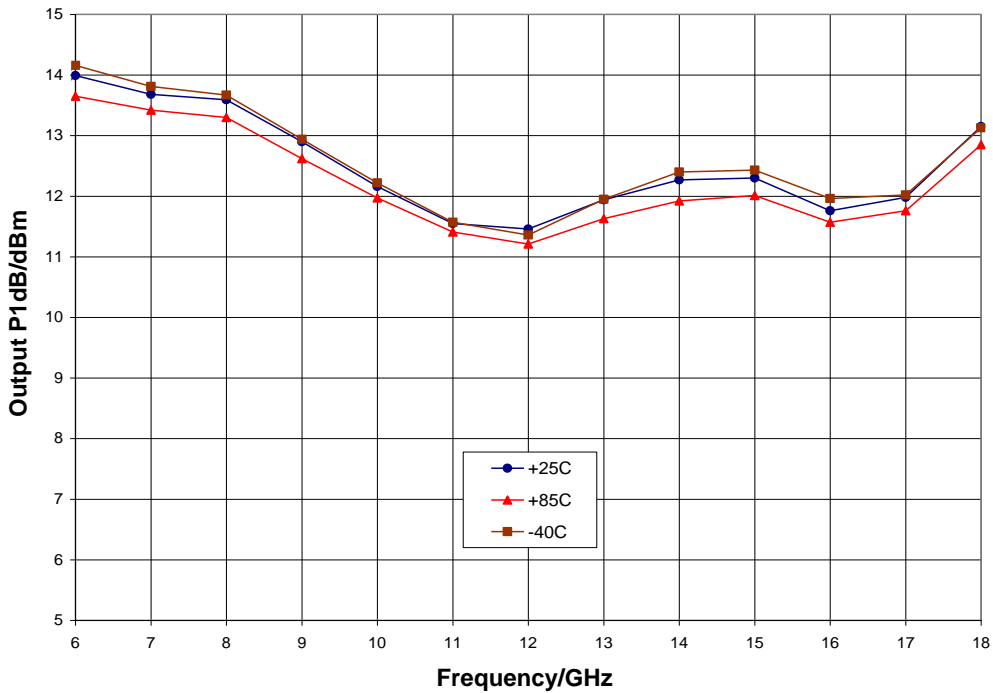

Typical Performance

Output IP3 vs. Temperature,  $V_{dd} = 3.0\text{ V}$

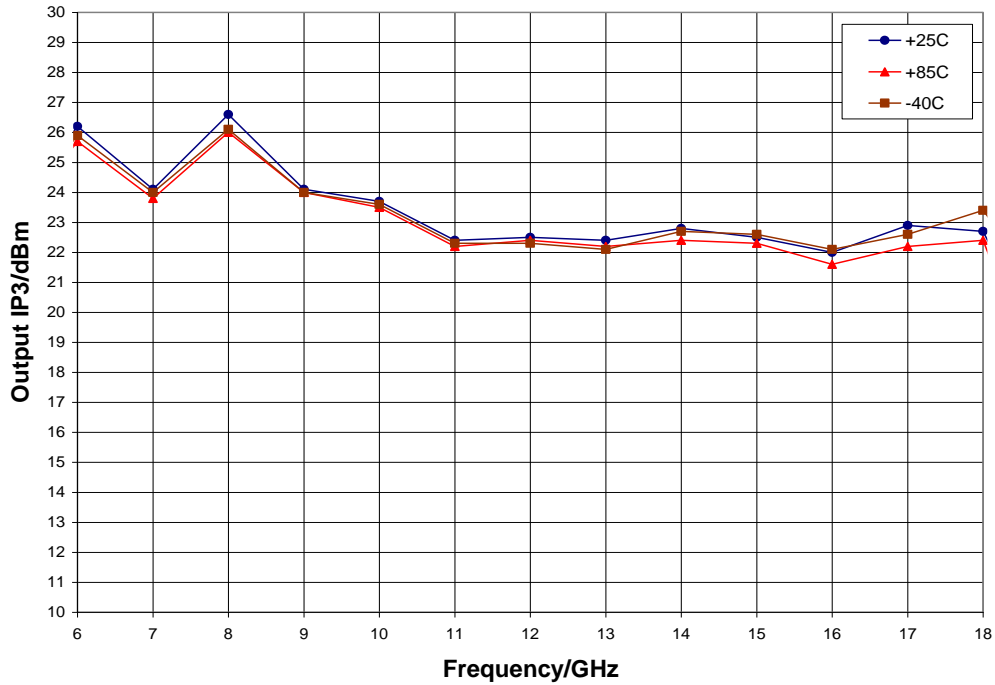

**Mechanical Information**

**Package Information and Dimensions**

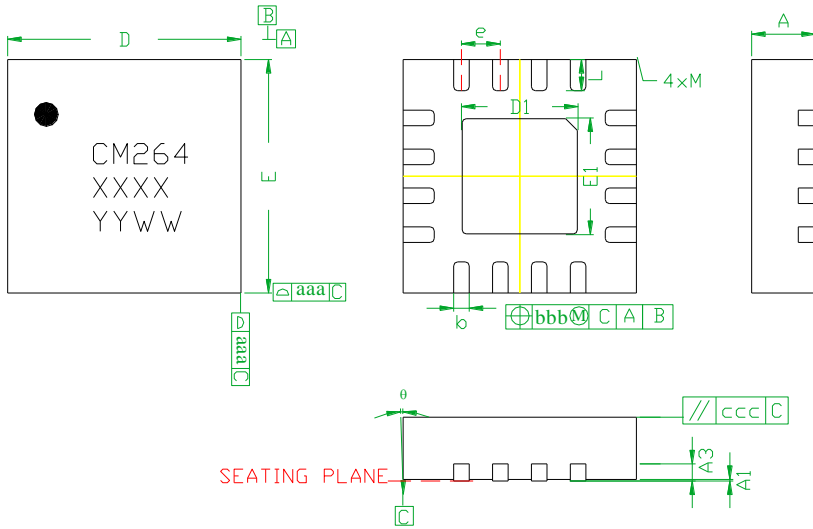

SYMBOLS	DIMENSIONS IN MILLIMETERS		
	MIN	NOM	MAX
A	0.80	0.90	1.00
A1	0	0.02	0.05
A3	---	0.25REF.	---
b	0.18	0.23	0.30
D	2.85	3.00	3.15
D1	---	1.5BSC	---
E	2.85	3.00	3.15
E1	---	1.5BSC	---
e	---	0.50BSC	---
L	0.30	0.40	0.50
θ	0	---	12
aaa	---	0.25	---
bbb	---	0.10	---
ccc	---	0.10	---
M	---	---	0.05

- Notes:
1. Dimensions are in millimeters
  2. RoHS compliant mold compound
  3. Lead frame material: Copper alloy
  4. Lead finish: 100% matte Sn
  5. Indicated dimension/tolerance applies to leads and exposed pads

**Recommended PCB Land Pattern**

Qorvo recommends that the user develop the land pattern that will provide the best design for proper solder reflow and device attach for their specific application. Please review Qorvo Application Note AN 105 for a recommended land pattern approach.

**Recommended Solder Reflow Profile**

Qorvo recommends screen printing with belt furnace reflow to ensure proper solder reflow and device attach. Please review Qorvo Application Note AN 102 for a recommended solder reflow profile.

## Pin Description

### Pin Diagram

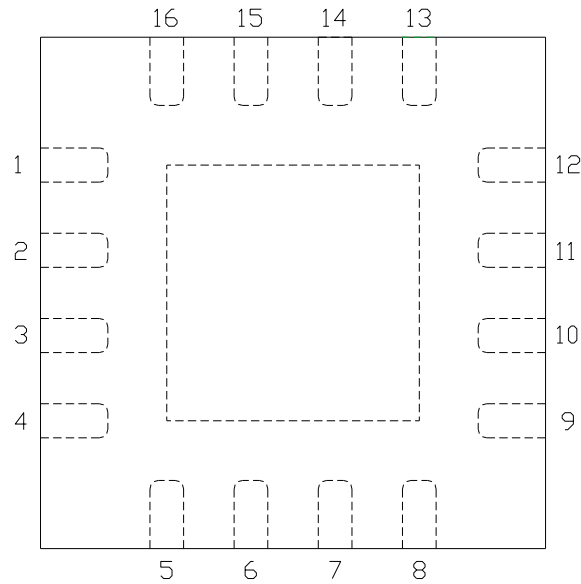

### Functional Description

Pin	Function	Description	Schematic
3	RF in	DC blocked and 50 ohm matched	
10	RF out	DC blocked and 50 ohm matched	
14	V <sub>dd</sub>	Power supply voltage Decoupling and bypass caps required	
4, 9 and die paddle	Ground	Connect to RF / DC ground	



**Applications Information**

**Application Circuit**

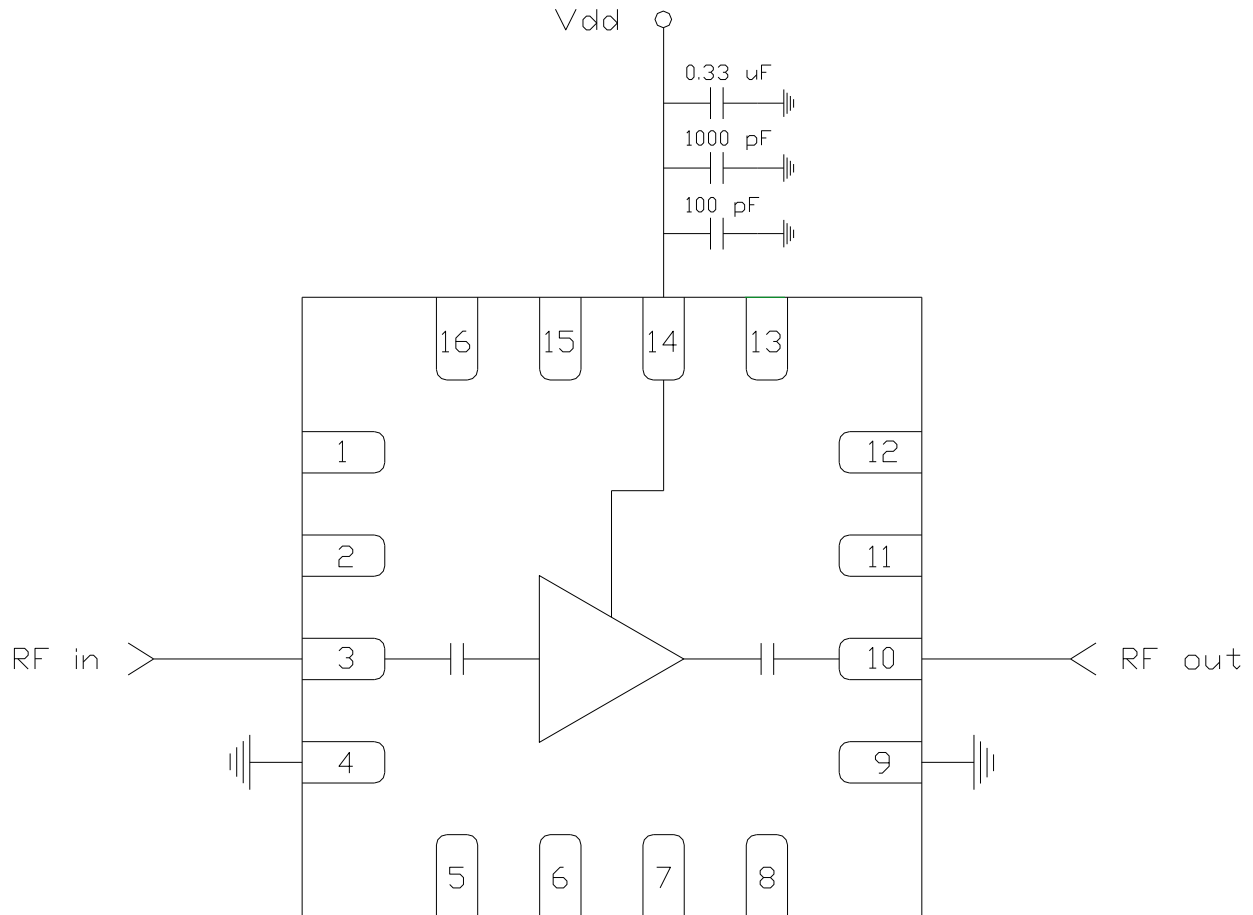

**Biasing and Operation**

The CMD264P3 is biased with a single positive drain supply. Performance is optimized when the drain voltage is set to +3.0 V, though it may be set to a minimum of +2.0 V and a maximum of +4.5 V.

RF power can be applied at any time.

**GaAs MMIC devices are susceptible to damage from Electrostatic Discharge. Proper precautions should be observed during handling, assembly and test.**

## Applications Information

### Evaluation Board

The circuit board shown has been developed for optimized assembly at Qorvo. A sufficient number of via holes should be used to connect the top and bottom ground planes. As surface mount processes vary, careful process development is recommended.

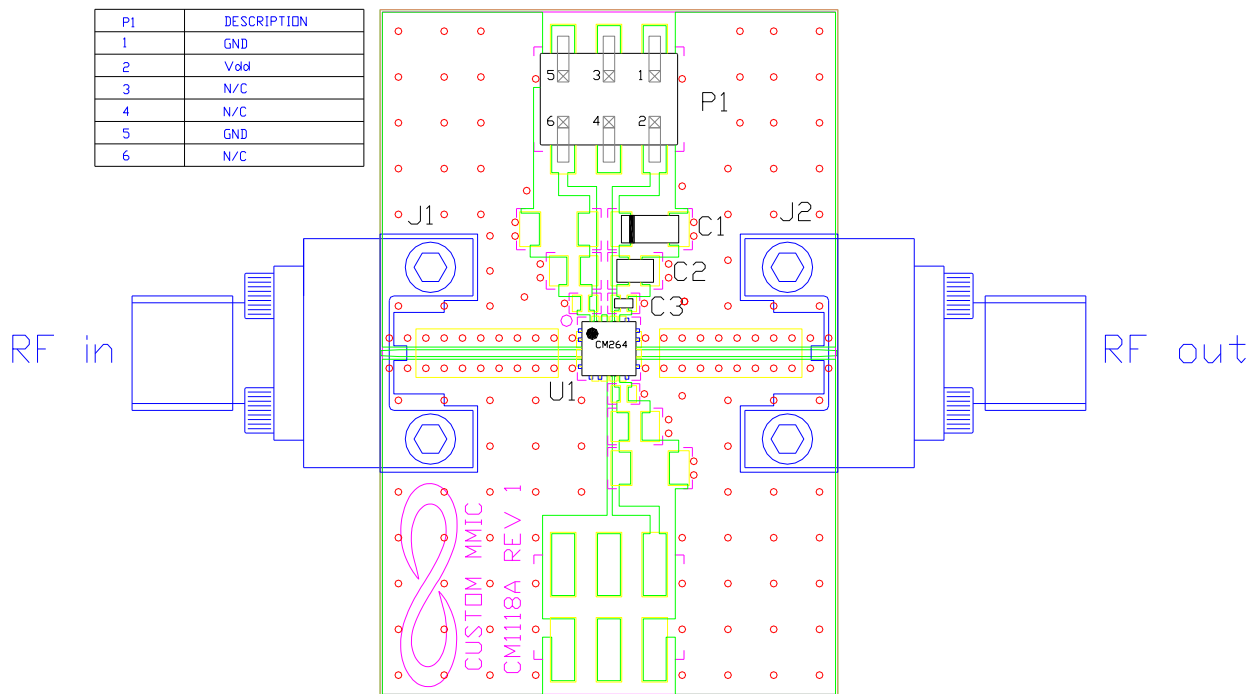

## Bill of Material

Designator	Value	Description
J1, J2		SMA End Launch Connector
P1		6 Pin Header
C1	0.33 $\mu$ F	Capacitor, Tantalum
C2	1000 pF	Capacitor, 0603
C3	100 pF	Capacitor, 0402
U1		CMD264P3 Low Noise Amplifier
PCB		CM118A Evaluation PCB