

Product Overview

The CMD270P3 is a broadband MMIC low noise amplifier housed in a leadless 3x3 mm plastic surface mount package. The CMD270P3 is ideally suited for EW and communications systems where small size and low power consumption are needed. The broadband device delivers greater than 16 dB of gain with a corresponding output 1 dB compression point of +18 dBm and a noise figure of 1.7 dB. The CMD270P3 is a 50 ohm matched design eliminating the need for external DC blocks and RF port matching.

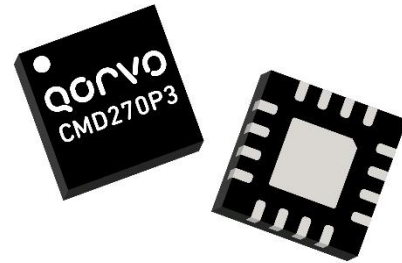

Functional Block Diagram

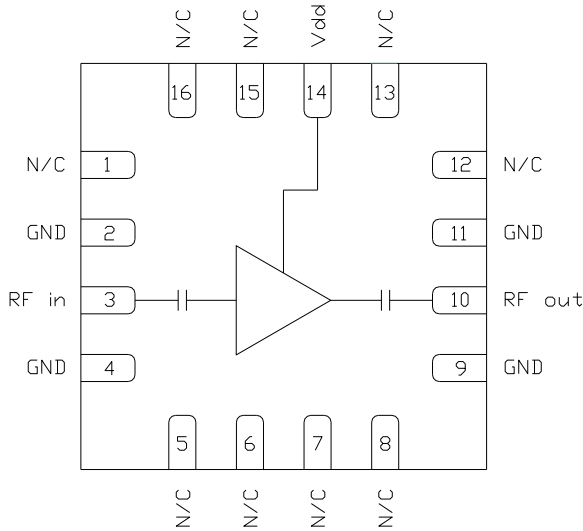

Key Features

- Ultra Low Noise Figure
- High Gain Broadband Performance
- Single Supply Voltage: +4.0 V @ 60 mA
- Pb-free RoHs Compliant 3x3 QFN Package

Ordering Information

| Part No. | Description |
|----------|--------------------|
| CMD270P3 | 100 pcs on 7" reel |

Electrical Performance ($V_{dd} = 4.0\text{ V}$, $T_A = 25^\circ\text{C}$, $F = 6\text{ GHz}$)

| Parameter | Min | Typ | Max | Units |
|--------------------|-----|-------|-----|-------|
| Frequency Range | | 4 - 8 | | GHz |
| Gain | | 16 | | dB |
| Noise Figure | | 1.7 | | dB |
| Input Return Loss | | 15 | | dB |
| Output Return Loss | | 11 | | dB |
| Output P1dB | | 18 | | dBm |
| Supply Current | | 60 | | mA |

Absolute Maximum Ratings

| Parameter | Rating |
|-------------------------------|--------------|
| Drain Voltage, V_{dd} | 5 V |
| RF Input Power | +20 dBm |
| Channel Temperature, T_{ch} | 150°C |
| Power Dissipation, P_{diss} | 523 mW |
| Thermal Resistance, Q_{JC} | 124.3°C/W |
| Operating Temperature | -40 to 85°C |
| Storage Temperature | -55 to 150°C |

Exceeding any one or combination of the maximum ratings may cause permanent damage to the device.

Recommended Operating Conditions

| Parameter | Min | Typ | Max | Units |
|-----------|-----|-----|-----|-------|
| V_{dd} | 2.0 | 4.0 | 5.0 | V |
| I_{dd} | | 60 | | mA |

Electrical performance is measured at specific test conditions. Electrical specifications are not guaranteed over all recommended operating conditions.

Electrical Specifications ($V_{dd} = 4.0$ V, $T_A = 25^\circ$ C)

| Parameter | Min | Typ | Max | Min | Typ | Max | Units |
|--------------------------------------|------|-------|-----|-----|-------|-----|-------|
| Frequency Range | | 4 - 6 | | | 6 - 8 | | GHz |
| Gain | 13.5 | 17.5 | 20 | 11 | 15.5 | 19 | dB |
| Noise Figure | | 1.8 | 2.6 | | 1.8 | 2.4 | dB |
| Input Return Loss | | 11 | | | 12 | | dB |
| Output Return Loss | | 15 | | | 15 | | dB |
| Output P1dB | | 18 | | | 19 | | dBm |
| Output IP3 | | 28 | | | 31 | | dBm |
| Supply Current | 40 | 60 | 80 | 40 | 60 | 80 | mA |
| Gain Temperature Coefficient | | 0.008 | | | 0.008 | | dB/°C |
| Noise Figure Temperature Coefficient | | 0.008 | | | 0.008 | | dB/°C |

Typical Performance

Broadband Performance, $V_{dd} = 4.0\text{ V}$, $I_{dd} = 60\text{ mA}$, $T_A = 25^\circ\text{ C}$

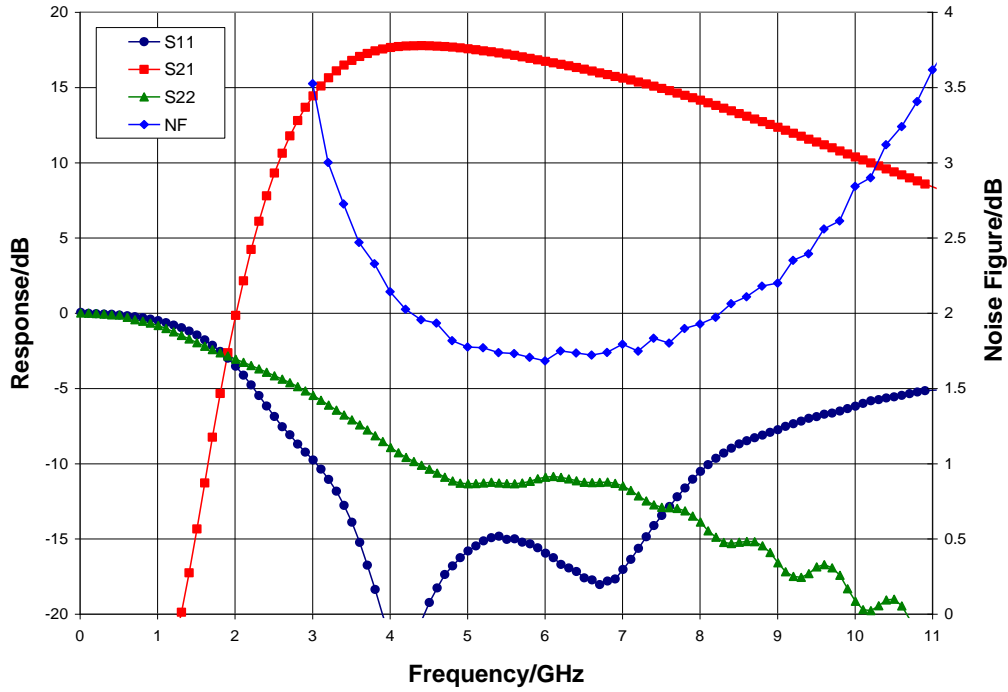

Narrow-band Performance, $V_{dd} = 4.0\text{ V}$, $I_{dd} = 60\text{ mA}$, $T_A = 25^\circ\text{ C}$

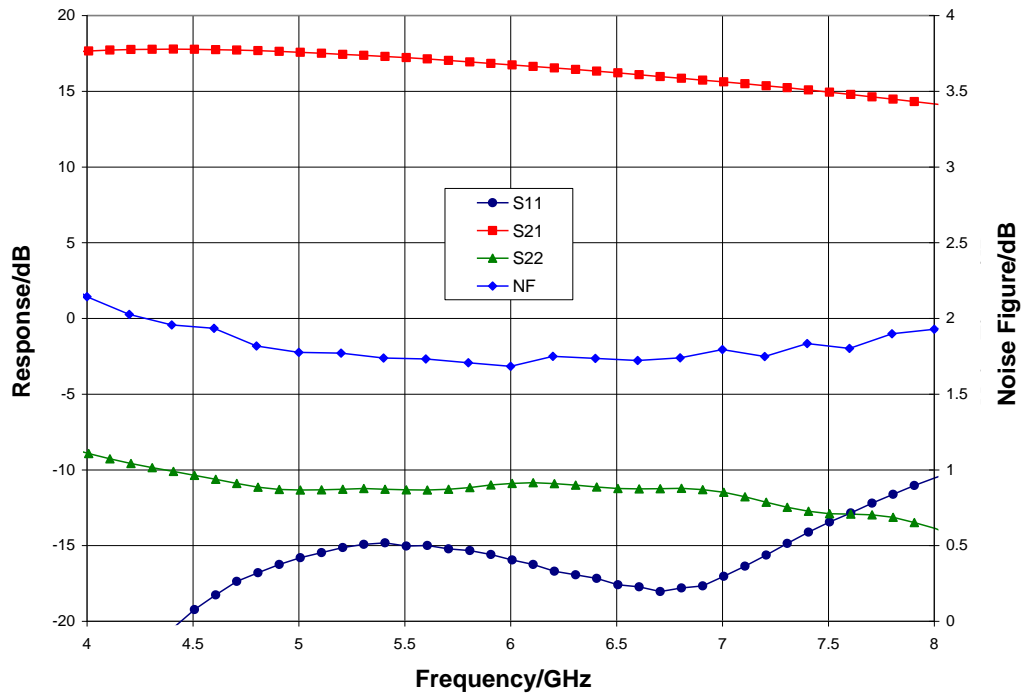

Typical Performance

Gain vs. Temperature, $V_{dd} = 4.0\text{ V}$

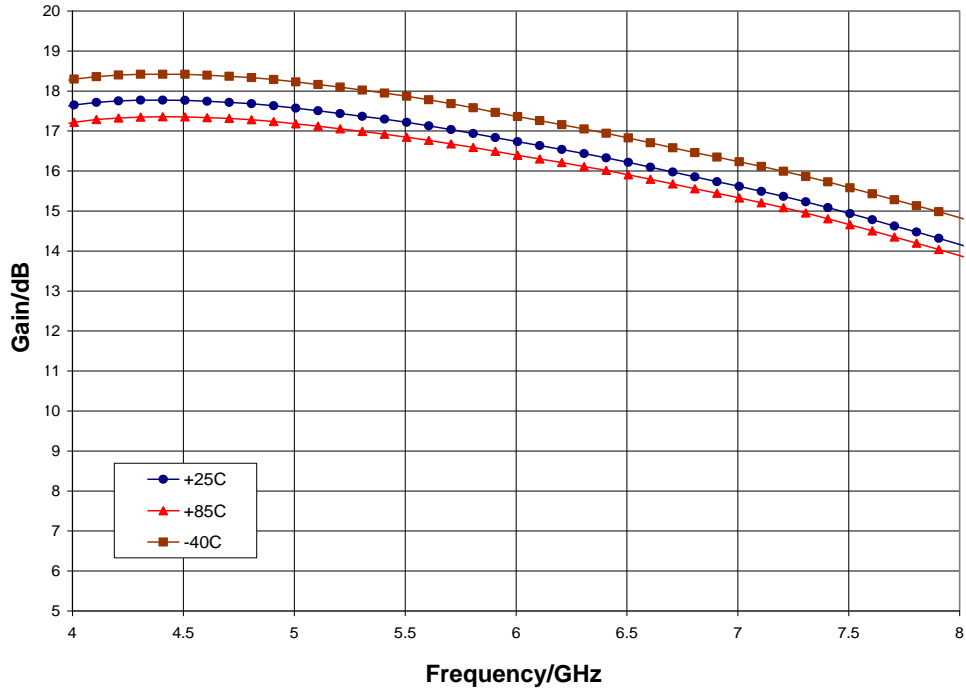

Noise Figure vs. Temperature, $V_{dd} = 4.0\text{ V}$

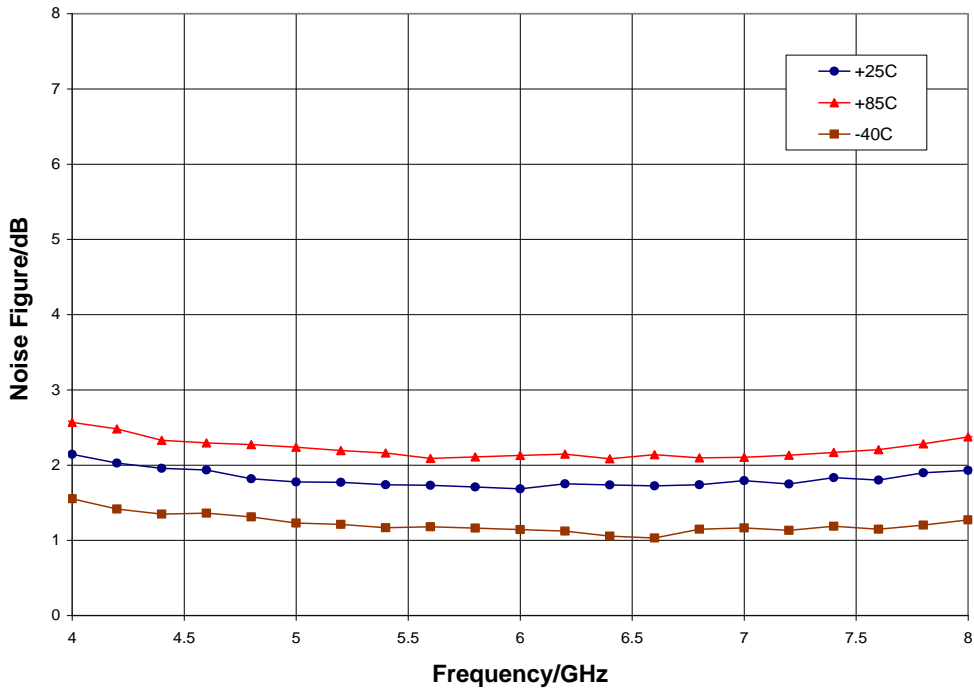

Typical Performance

P1dB vs. Temperature, $V_{dd} = 4.0\text{ V}$

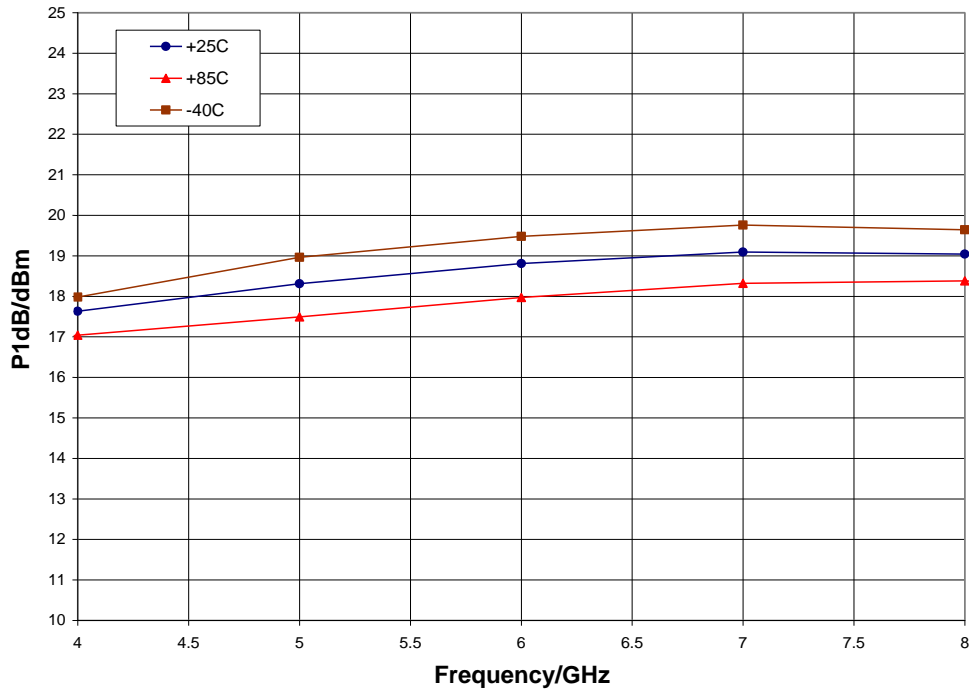

Output IP3 vs. Temperature, $V_{dd} = 4.0\text{ V}$

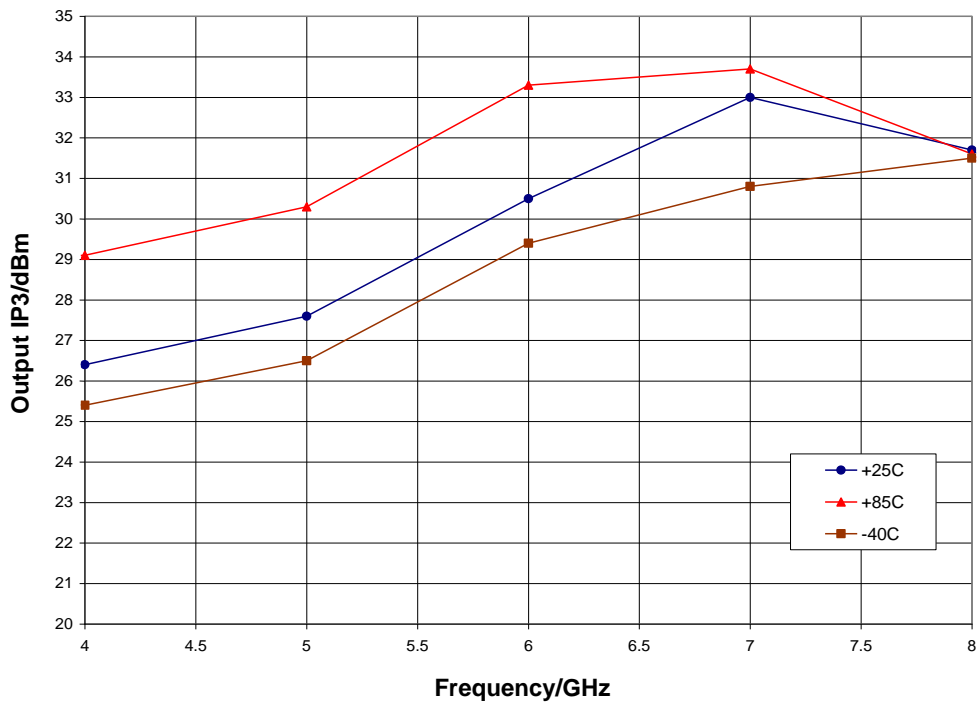

Mechanical Information

Package Information and Dimensions

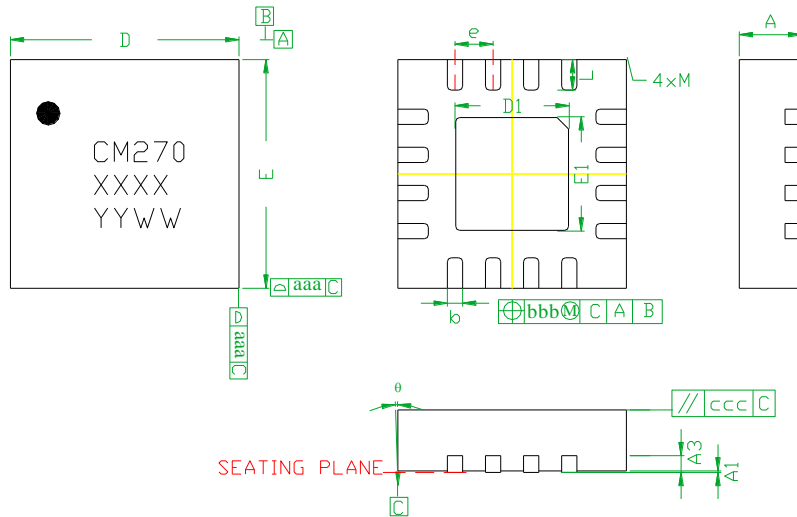

| SYMBOLS | DIMENSIONS IN MILLIMETERS | | |
|---------|---------------------------|----------|------|
| | MIN | NOM | MAX |
| A | 0.80 | 0.90 | 1.00 |
| A1 | 0 | 0.02 | 0.05 |
| A3 | --- | 0.25REF. | --- |
| b | 0.18 | 0.23 | 0.30 |
| D | 2.85 | 3.00 | 3.15 |
| D1 | --- | 1.5BSC | --- |
| E | 2.85 | 3.00 | 3.15 |
| E1 | --- | 1.5BSC | --- |
| e | --- | 0.50BSC | --- |
| L | 0.30 | 0.40 | 0.50 |
| θ | 0 | --- | 12 |
| aaa | --- | 0.25 | --- |
| bbb | --- | 0.10 | --- |
| ccc | --- | 0.10 | --- |
| M | --- | --- | 0.05 |

Notes:

1. Dimensions are in millimeters
2. RoHS compliant mold compound
3. Lead frame material: Copper alloy
4. Lead finish: 100% matte Sn
5. Indicated dimension/tolerance applies to leads and exposed pad

Recommended PCB Land Pattern

Qorvo recommends that the user develop the land pattern that will provide the best design for proper solder reflow and device attach for their specific application. Please review Qorvo Application Note AN 105 for a recommended land pattern approach.

Recommended Solder Reflow Profile

Qorvo recommends screen printing with belt furnace reflow to ensure proper solder reflow and device attach. Please review Qorvo Application Note AN 102 for a recommended solder reflow profile.

Pin Description

Pin Diagram

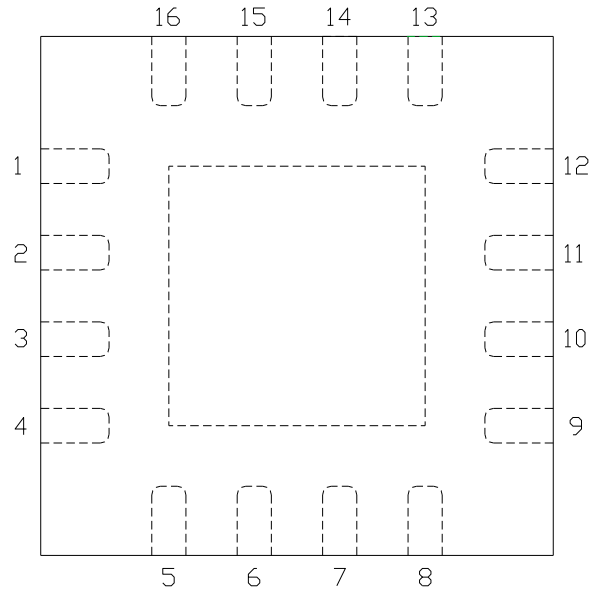

Functional Description

| Pin | Function | Description | Schematic |
|----------------------------|-----------------|---|-----------|
| 1, 5 - 8, 12, 13, 15, 16 | N/C | No connection required These pins may be connected to RF / DC ground | |
| 2, 4, 9, 11 and die paddle | Ground | Connect to RF / DC ground | |
| 3 | RF in | DC blocked and 50 ohm matched | |
| 10 | RF out | DC blocked and 50 ohm matched | |
| 14 | V _{dd} | Power supply voltage Decoupling and bypass caps required | |

Applications Information

Application Circuit

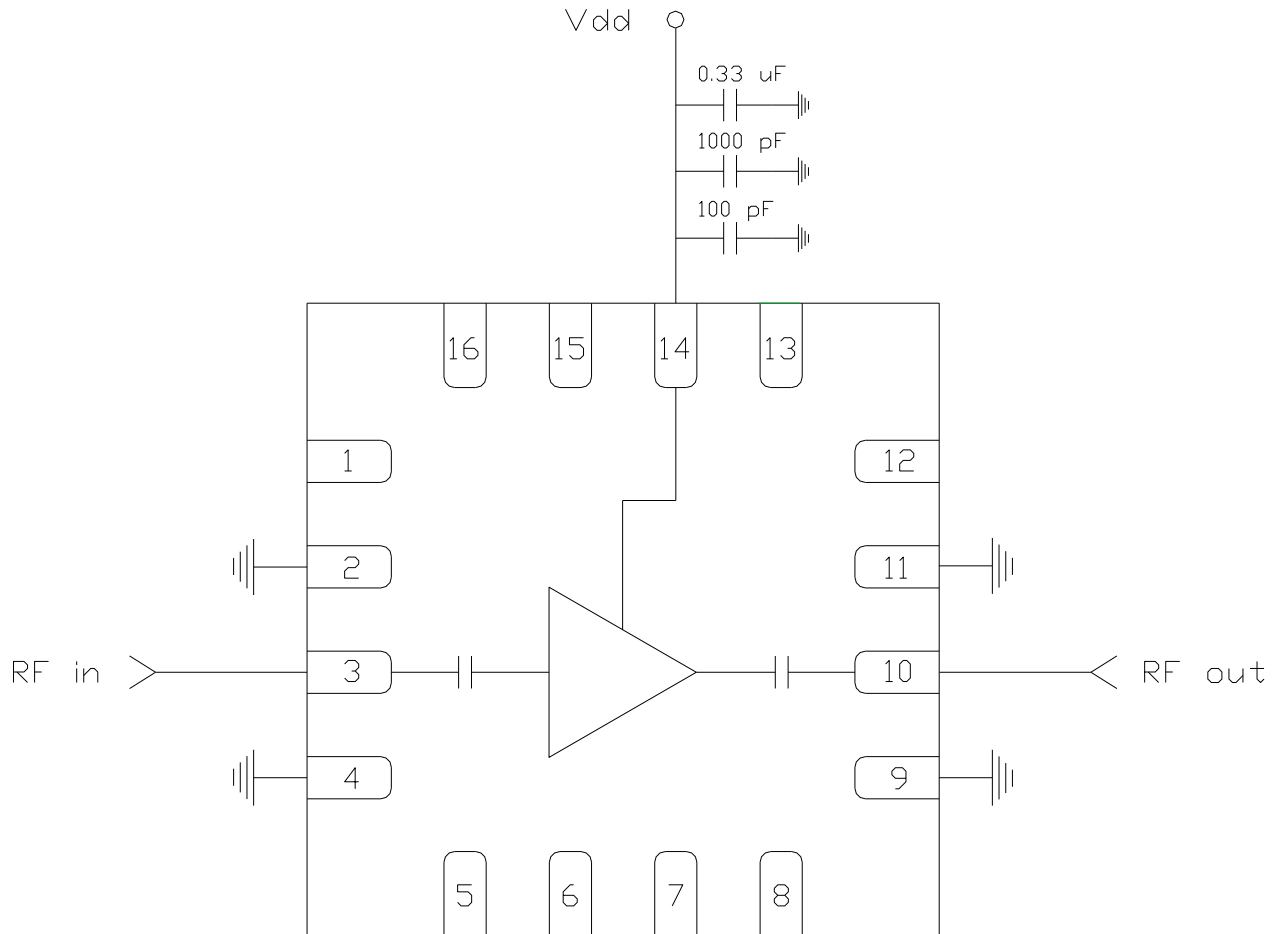

Biasing and Operation

The CMD270P3 is biased with a single 4.0 V positive drain supply.

RF power can be applied at any time.

GaAs MMIC devices are susceptible to damage from Electrostatic Discharge. Proper precautions should be observed during handling, assembly and test.

Applications Information

Evaluation Board

The circuit board shown has been developed for optimized assembly at Qorvo. A sufficient number of via holes should be used to connect the top and bottom ground planes. As surface mount processes vary, careful process development is recommended.

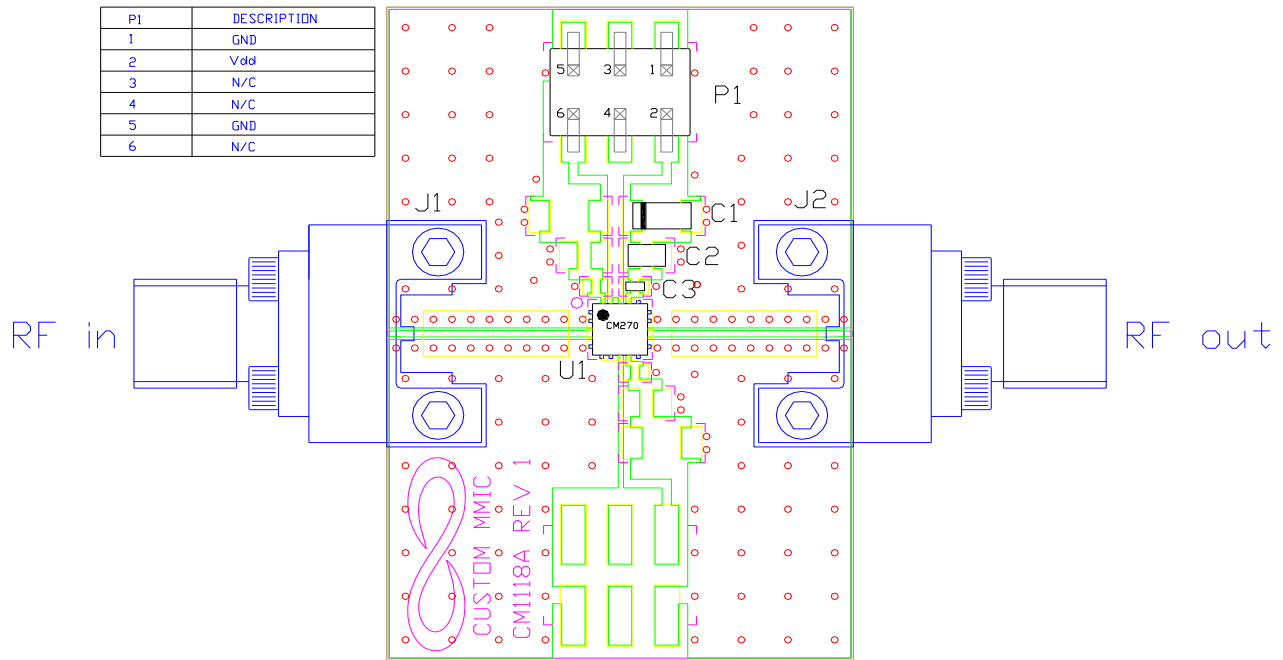

Bill of Material

| Designator | Value | Description |
|------------|--------------|------------------------------|
| J1, J2 | | SMA End Launch Connector |
| P1 | | 10 Pin Header |
| C1 | 0.33 μ F | Capacitor, Tantalum |
| C2 | 1000 pF | Capacitor, 0603 |
| C3 | 100 pF | Capacitor, 0402 |
| U1 | | CMD270P3 Low Noise Amplifier |
| PCB | | CM118A Evaluation PCB |