



CMD272P3

DC-10 GHz DPDT Transfer Switch

Features

- ▶ Low loss broadband performance
- ▶ High isolation
- ▶ Non-reflective design
- ▶ Pb-free RoHs compliant 3x3 SMT package

Description

The CMD272P3 is a low loss broadband positive control MMIC DPDT transfer switch housed in a leadless 3x3 mm surface mount package. The CMD272P3 covers DC to 10 GHz and offers a low insertion loss of 1.6 dB and high isolation of 43 dB at 5 GHz. The CMD272P3 operates using complementary control voltage logic lines of 0/+5 V.

Functional Block Diagram

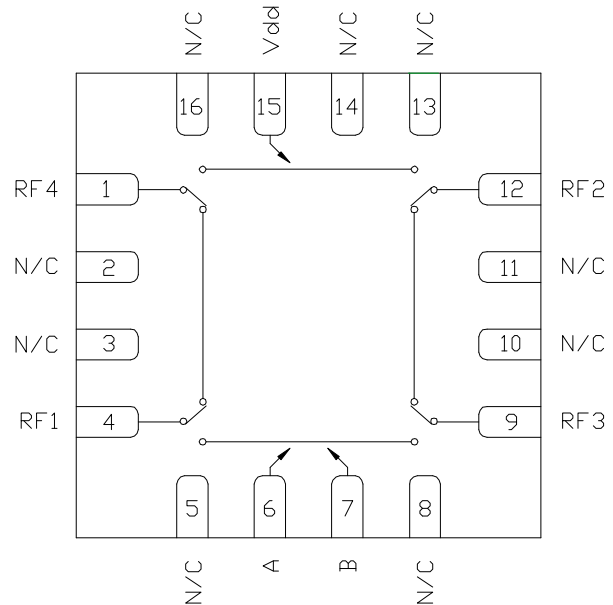

Electrical Performance - $V_{ctl} = 0/+5\text{ V}$, $V_{dd} = +5\text{ V}$, $T_A = 25\text{ }^\circ\text{C}$, $F = 5\text{ GHz}$

Parameter	Min	Typ	Max	Units
Frequency Range	DC - 10			GHz
Insertion Loss		1.6		dB
Isolation		43		dB
Return Loss		13		dB
Input P0.1dB		25		dBm
Input IP3		38		dBm
Switching Speed		10		ns

ver 2.0 0618



CMD272P3

DC-10 GHz DPDT Transfer Switch

Specifications

Absolute Maximum Ratings

Parameter	Rating
RF Input Power	+27 dBm
Bias Voltage (Vdd)	+7.0V
Control Voltage Range (A,B)	-0.5V to Vdd + 1V
Channel Temperature, T _{ch}	150 °C
Thermal Resistance, Θ_{jc}	34.5 °C/W
Operating Temperature	-40 to 85 °C
Storage Temperature	-55 to 150 °C

Exceeding any one or combination of the maximum ratings may cause permanent damage to the device.

Bias Voltage & Current

Vdd Range = +5.0V ± 10%		
Vdd (V)	I _{dd} (Typ) (uA)	I _{dd} (Max) (uA)
+5	5	10

TTL/CMOS Control Voltages

State	Bias Condition
Low	0V to +0.2V @ 1 uA Typ
High	Vdd ± 0.2V @ 1 uA Typ

Truth Table

Control Input					
A	B	RF4 to RF2	RF1 to RF3	RF4 to RF1	RF2 to RF3
Low	High	On	On	Off	Off
High	Low	Off	Off	On	On

Electrical Specifications - V_{ctl} = 0/+5 V, Vdd = +5 V T_A = 25 °C

Parameter	Min	Typ	Max	Min	Typ	Max	Min	Typ	Max	Units
Frequency Range	DC - 4			DC - 8			DC - 10			GHz
Insertion Loss		1.2	1.8		1.5	2.1		1.6	2.4	dB
Isolation	37	44		32	40		28	35		dB
Return Loss		15			13			11		dB
Input P0.1dB		24			24			24		dBm
Input IP3		38			38			38		dBm
Switching Speed		10			10			10		ns

ver 2.0 0618

Typical Performance

Insertion Loss vs. Temperature

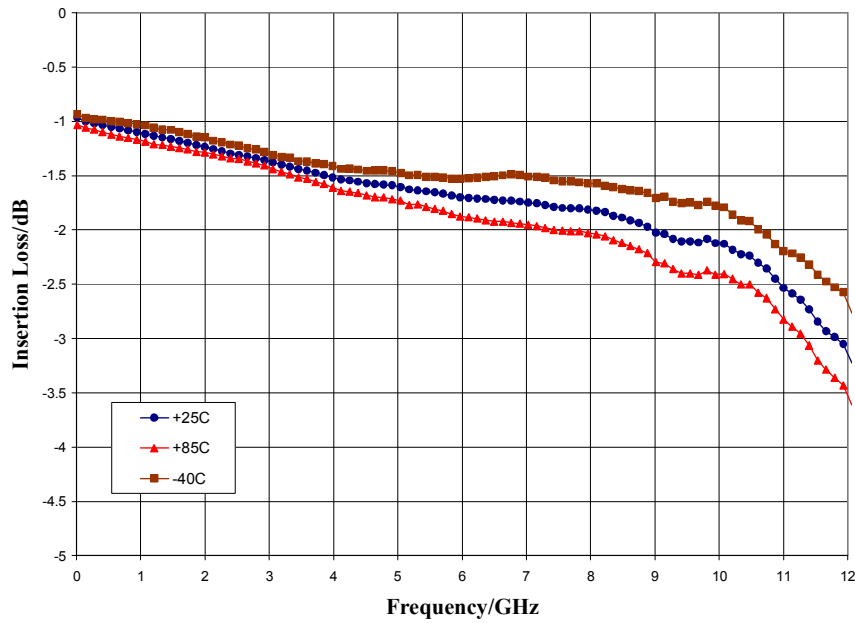

Return Loss

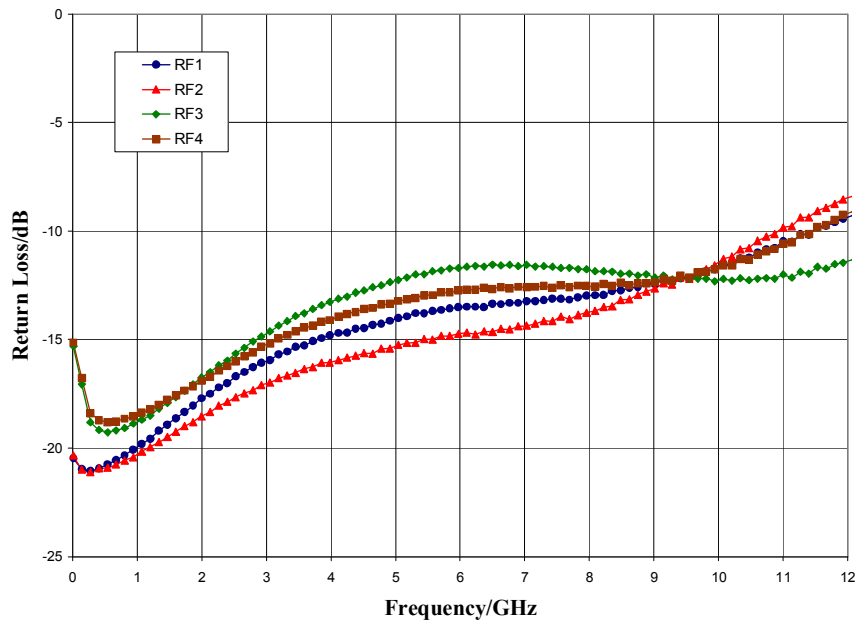

ver 2.0 0618

Typical Performance

Isolation

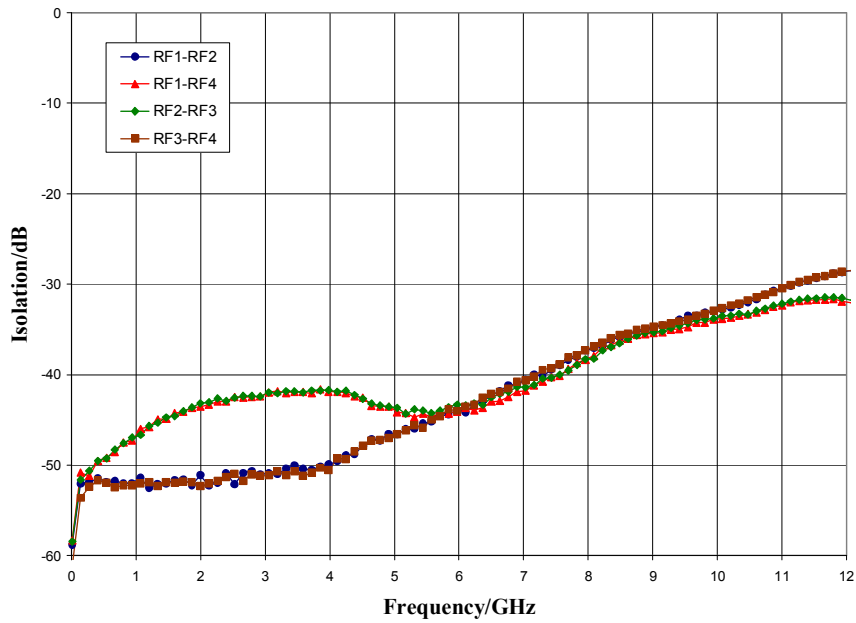

Input P0.1dB Compression Point vs. Temperature

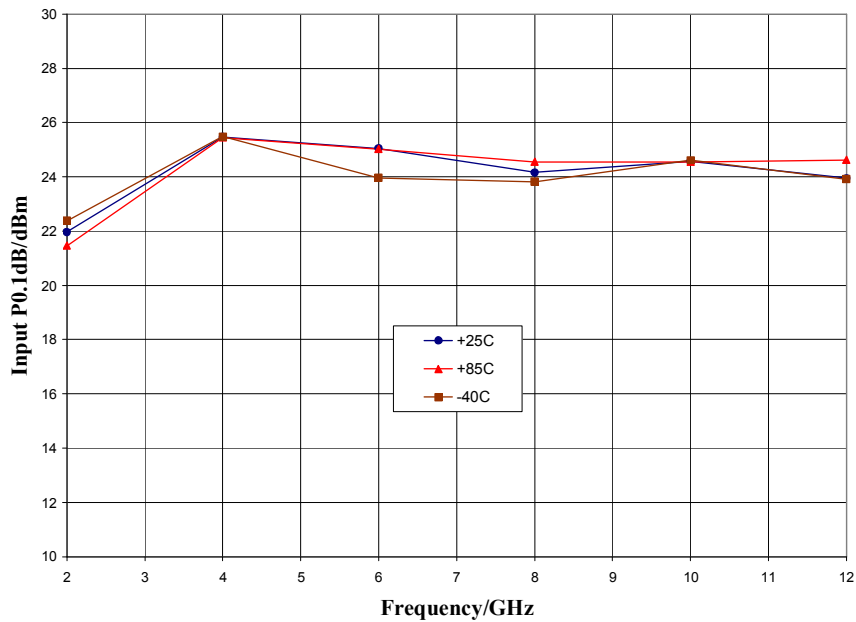

ver 2.0 0618

Typical Performance

Input Third Order Intercept Point vs. Temperature

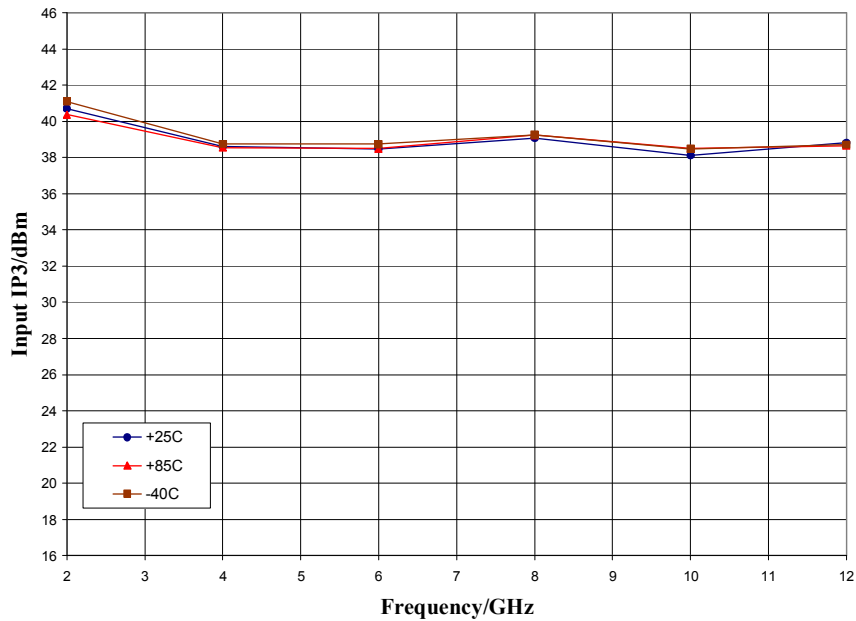

Mechanical Information

Package Information and Dimensions

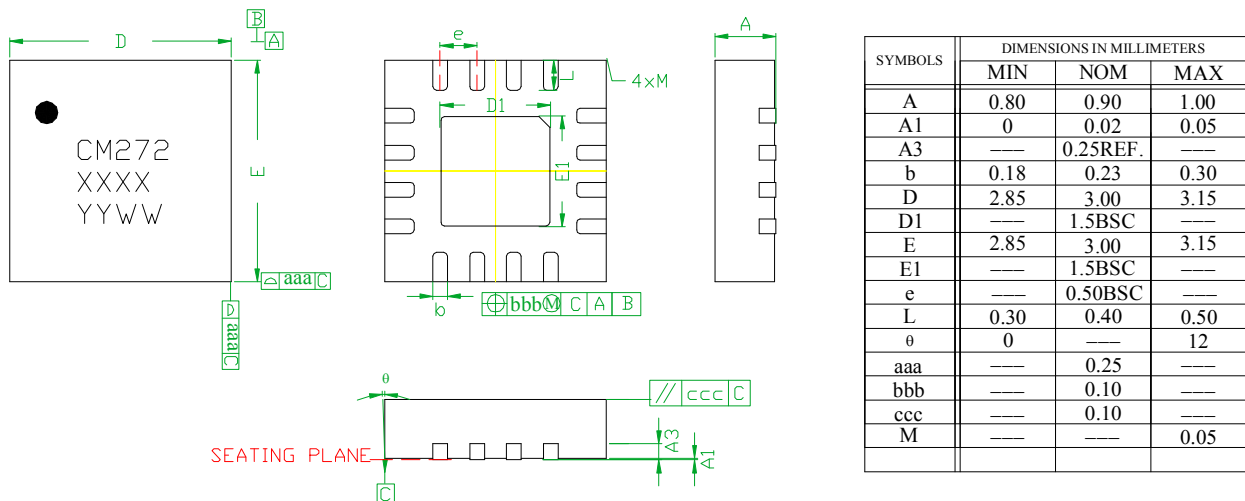

- NOTES:
1. DIMENSIONS ARE IN MILLIMETERS
 2. RoHS COMPLIANT MOLD COMPOUND
 3. LEADFRAME MATERIAL: COPPER ALLOY
 4. LEAD FINISH: 100% MATTE Sn
 5. INDICATED DIMENSION/TOLERANCE APPLIES TO LEADS AND EXPOSED PAD

Recommended PCB Land Pattern

Custom MMIC Design Services recommends that the user develop the land pattern that will provide the best design for proper solder reflow and device attach for their specific application. Please review Custom MMIC Application Note AN 105 for a recommended land pattern approach.

Recommended Solder Reflow Profile



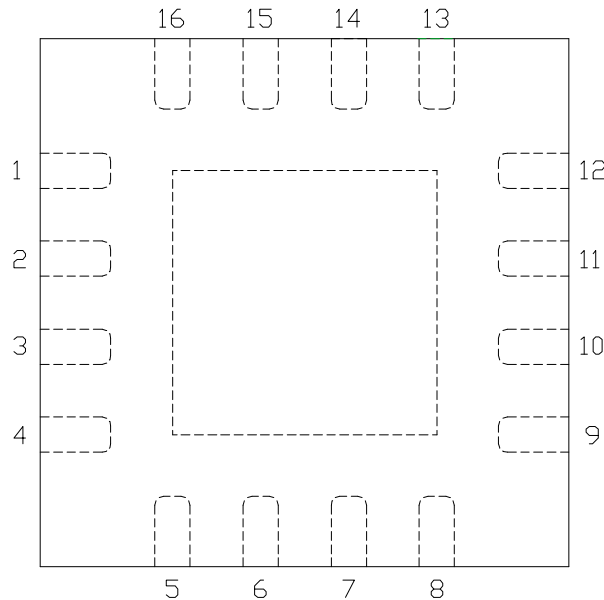

Custom MMIC Design Services recommends screen printing with belt furnace reflow to ensure proper solder reflow and device attach. Please review Custom MMIC Application Note AN 102 for a recommended solder reflow profile.

Pin Description

Pin Diagram

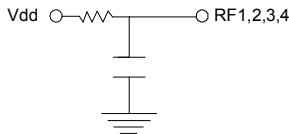

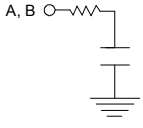
Functional Description

Pin	Function	Description	Schematic
1,4, 9,12	RF4, RF1, RF3, RF2,	These pins are DC coupled and matched to 50 Ohm. Blocking capacitors are required	
15	Vdd	Power supply voltage	
6	CTLA	See truth table and control voltage table	
7	CTLB	See truth table and control voltage table	
2,3,5,8,10,11, 13,14,16	N/C	No connection required. These pins may be connected to RF/DC ground	
Die paddle	Ground	Connect to RF / DC ground	

ver 2.0 0618