

Product Overview

The CMD291 is a wideband GaAs MMIC driver amplifier die which operates from 16 to 24 GHz. The broadband device is ideally suited for applications requiring high dynamic range. The CMD291 delivers 23 dB of gain with a corresponding output 1 dB compression point of +25.5 dBm and output IP3 of 32 dBm at 20 GHz. The amplifier is a 50 ohm matched design which eliminates the need for external DC blocks and RF port matching. The CMD291 offers full passivation for increased reliability and moisture protection.

Key Features

- Wideband Performance
- High Gain
- High Linearity
- HMC498 Replacement
- Small Die Size

Functional Block Diagram

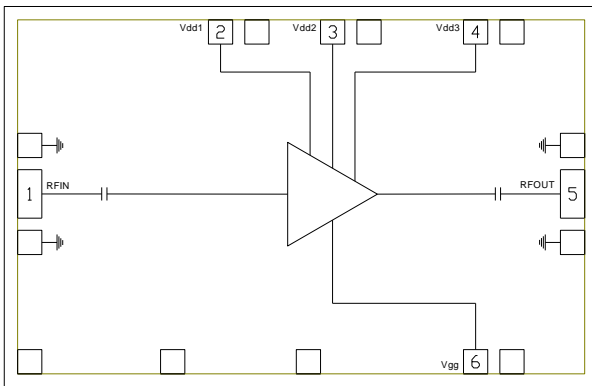

Ordering Information

Part No.	Description
CMD291	100 pcs gel pack

Electrical Performance ($V_{dd} = 5\text{ V}$, $I_{dd} = 250\text{ mA}$, $T_A = 25^\circ\text{ C}$, $F = 20\text{ GHz}$)

Parameter	Min	Typ	Max	Units
Frequency Range		16 - 24		GHz
Gain		23		dB
Noise Figure		5		dB
Input Return Loss		19		dB
Output Return Loss		15		dB
Output P1dB		25.5		dBm
Psat		27		dBm
Output IP3		32		dBm
Supply Current		250		mA

Absolute Maximum Ratings

Parameter	Rating
Drain Voltage, V_{dd}	5.5
Gate Voltage, V_{gg}	-2.5 V to 0 V
RF Input Power	+18 dBm
Channel Temperature, T_{ch}	150° C
Power Dissipation, P_{diss}	1.83 W
Thermal Resistance, Q_{JC}	35.5° C/W
Operating Temperature	-55 to 85° C
Storage Temperature	-55 to 150° C

Exceeding any one or combination of the maximum ratings may cause permanent damage to the device.

Recommended Operating Conditions

Parameter	Min	Typ	Max	Units
V_{dd}	3	5	5.5	V
I_{dd}		250		mA
V_{gg}		-0.5		V

Electrical performance is measured at specific test conditions. Electrical specifications are not guaranteed over all recommended operating conditions.

Electrical Specifications ($V_{dd} = 5\text{ V}$, $I_{dd} = 250\text{ mA}$, $T_A = 25^\circ\text{ C}$)

Parameter	Min	Typ	Max	Min	Typ	Max	Units
Frequency Range	16 - 20			20 - 24			GHz
Gain	20	23		19	22.5		dB
Noise Figure		5			5		dB
Input Return Loss		15			20		dB
Output Return Loss		13			15		dB
Output P1dB	22.5	25.5		23	26		dBm
Psat		26.5			27		dBm
Output IP3		33.5			32.5		dBm
Supply Current		250	325		250	325	mA
Gain Temperature Coefficient		0.029			0.031		dB/°C
Noise Figure Temperature Coefficient		0.014			.014		dB/° C

Typical Performance

Broadband Performance, $V_{dd} = 5\text{ V}$, $I_{dd} = 250\text{ mA}$, $T_A = 25^\circ\text{ C}$

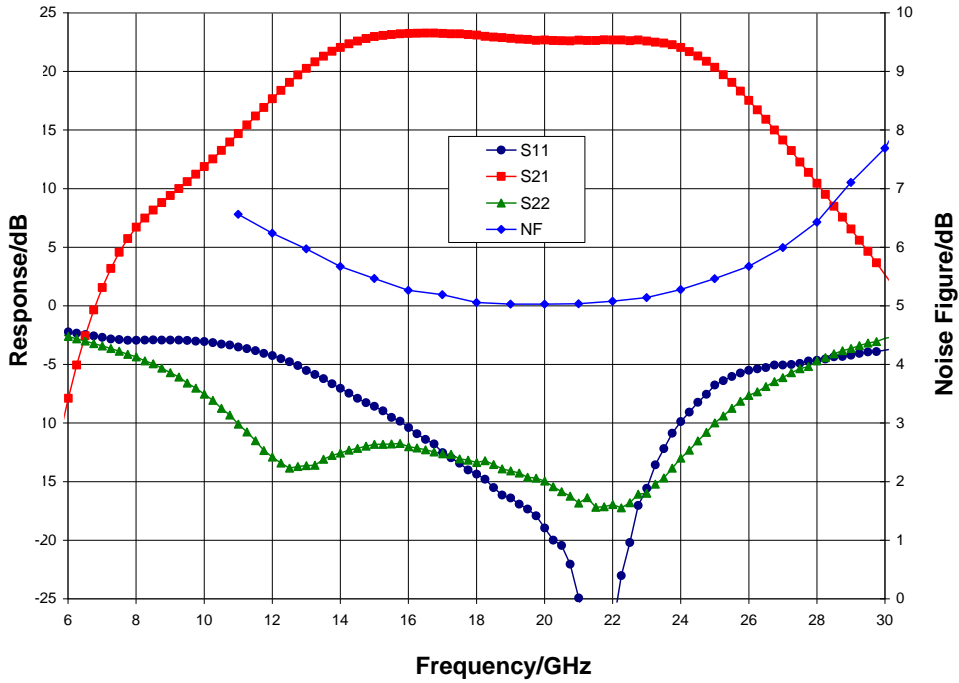

Narrow-band Performance, $V_{dd} = 5\text{ V}$, $I_{dd} = 250\text{ mA}$, $T_A = 25^\circ\text{ C}$

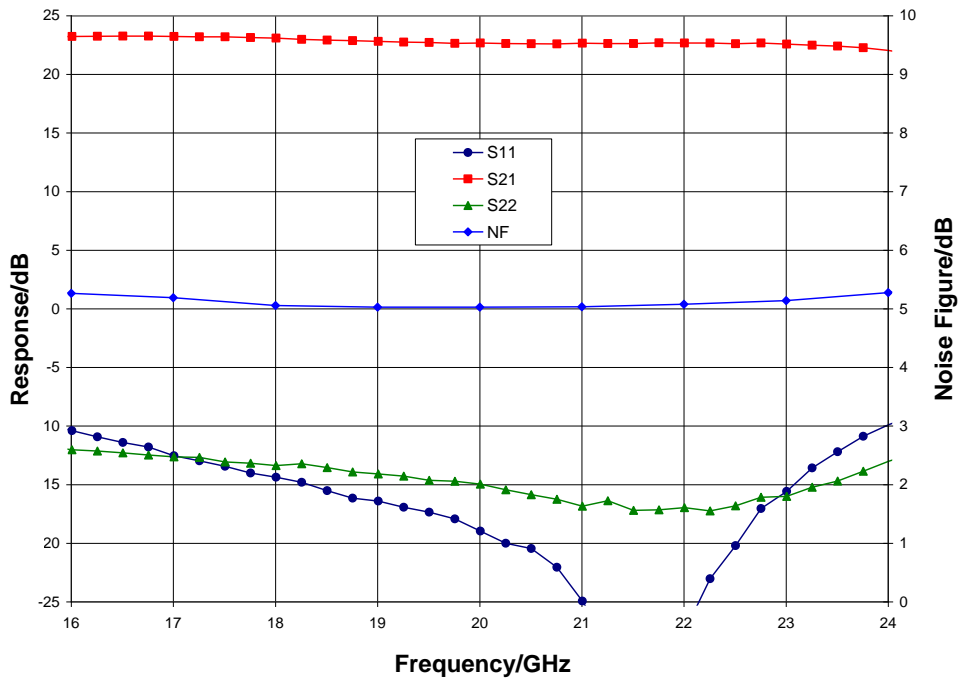

Typical Performance

Gain vs. Temperature, $V_{dd} = 5\text{ V}$

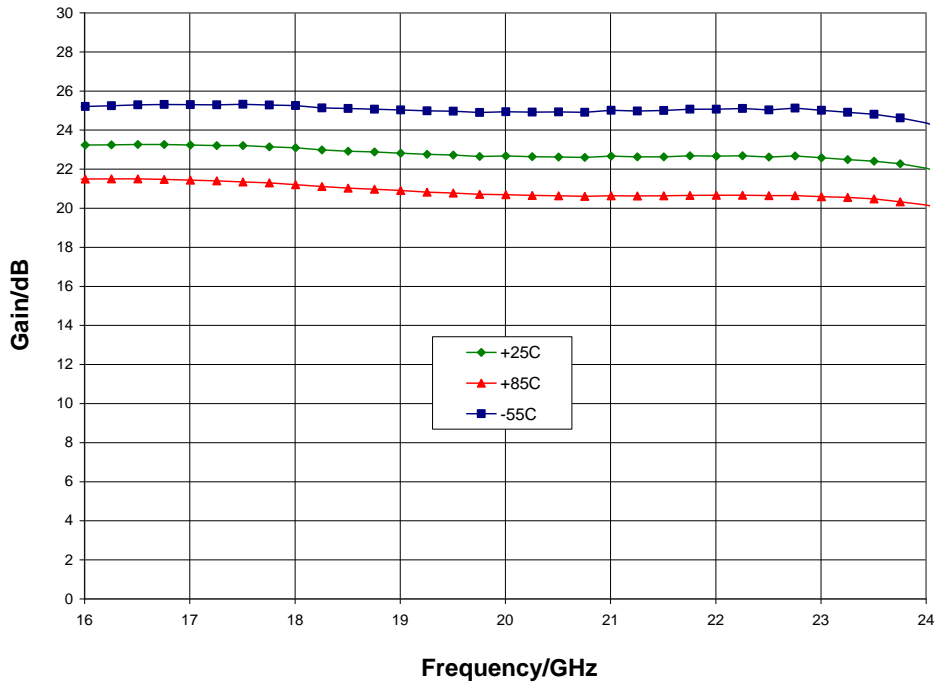

Gain vs. V_{dd} , $I_{dd} = 250\text{ mA}$, $T_A = 25^\circ\text{ C}$

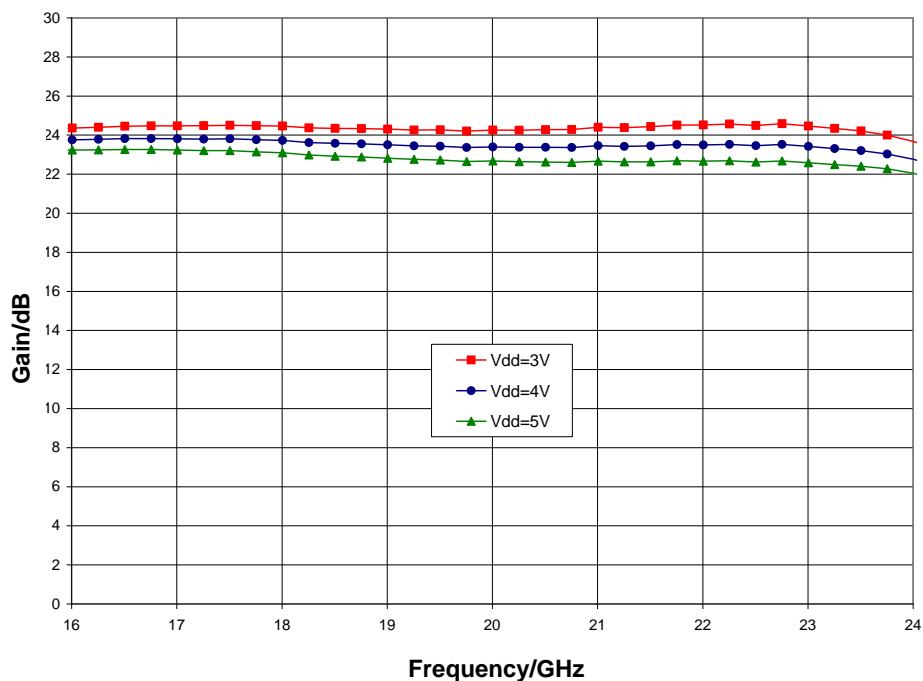

Typical Performance

Noise Figure vs. Temperature, $V_{dd} = 5\text{ V}$

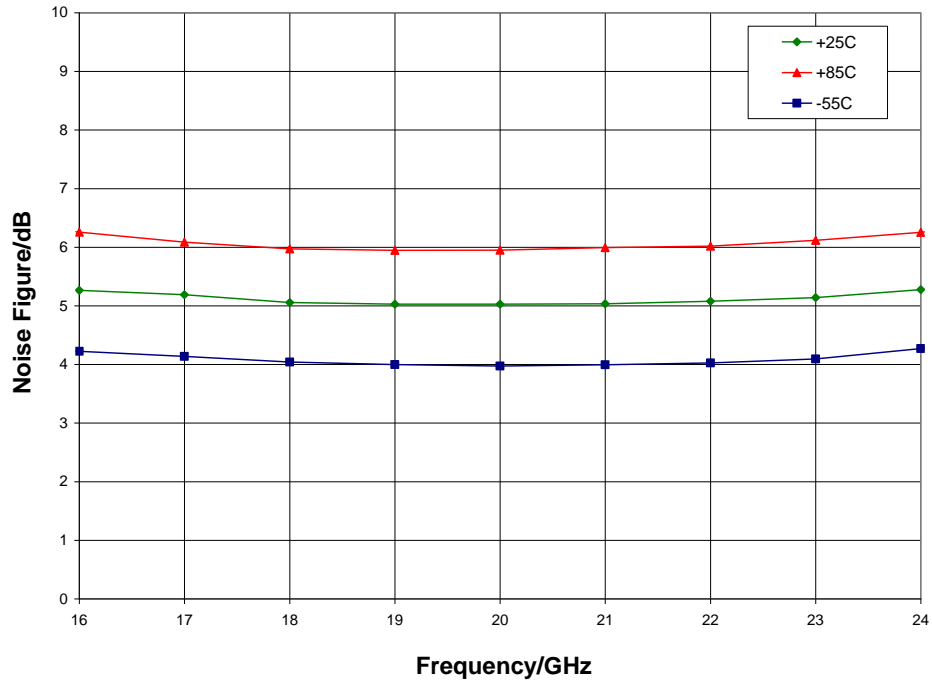

Noise Figure vs. V_{dd} , $I_{dd} = 250\text{ mA}$, $T_A = 25^\circ\text{ C}$

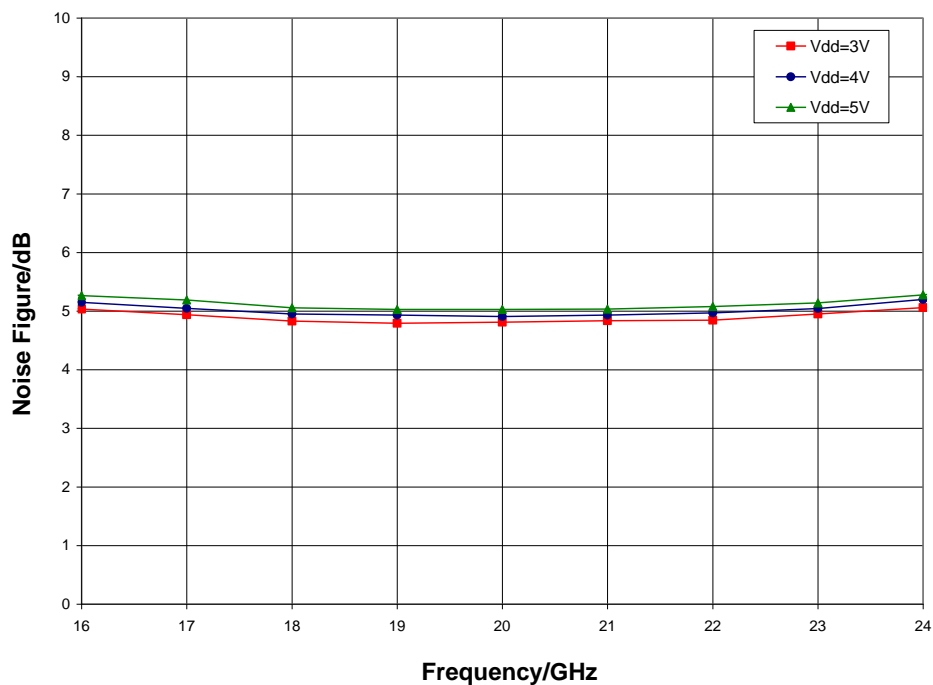

Typical Performance

P1dB vs. Temperature, $V_{dd} = 5\text{ V}$

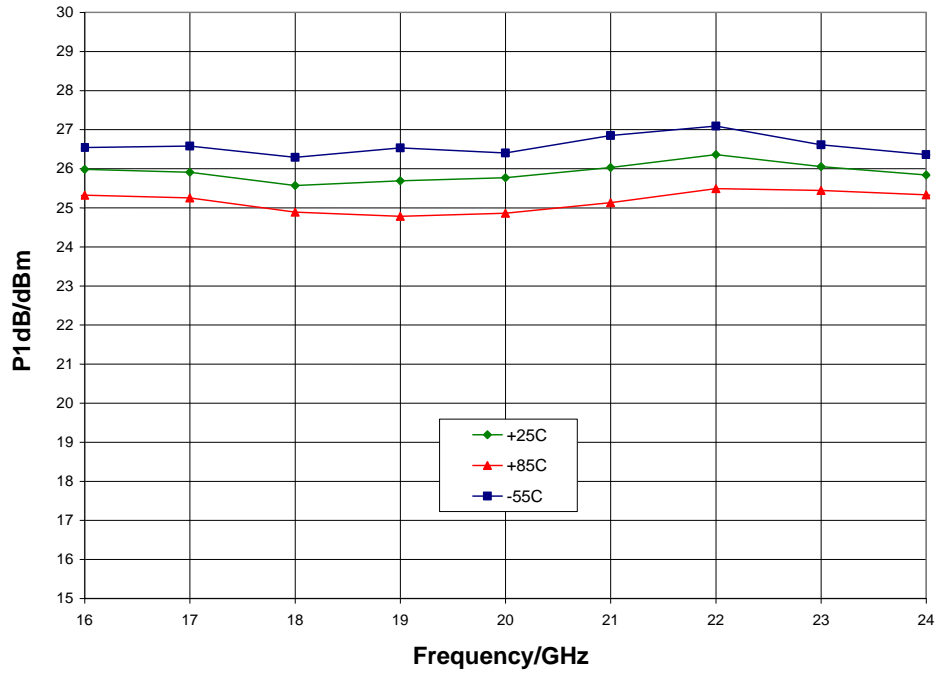

P1dB vs. V_{dd} , $I_{dd} = 250\text{ mA}$, $T_A = 25^\circ\text{ C}$

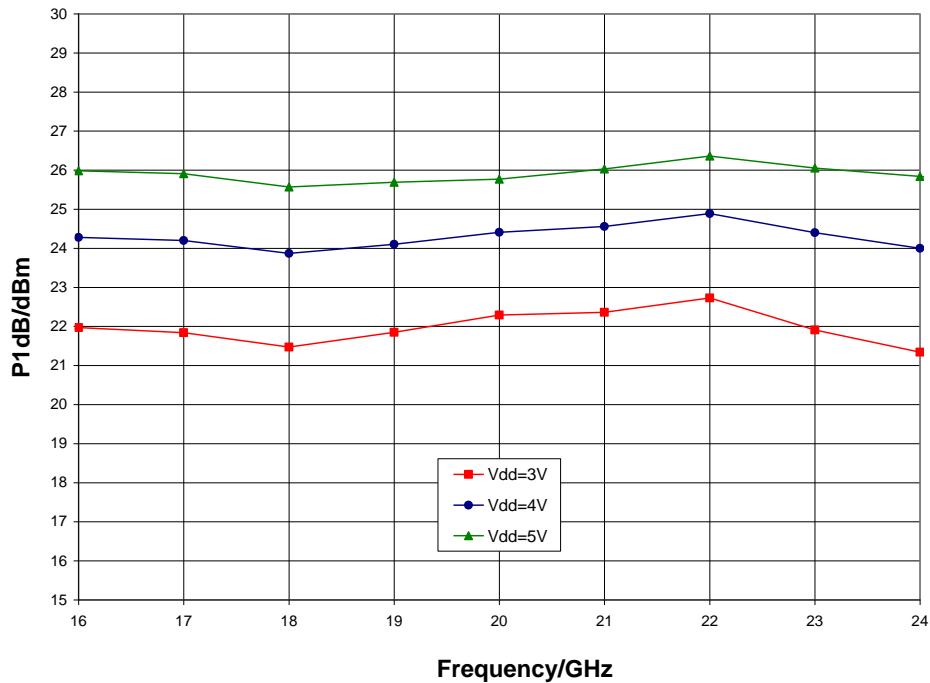

Typical Performance

Psat vs. Temperature, $V_{dd} = 5\text{ V}$

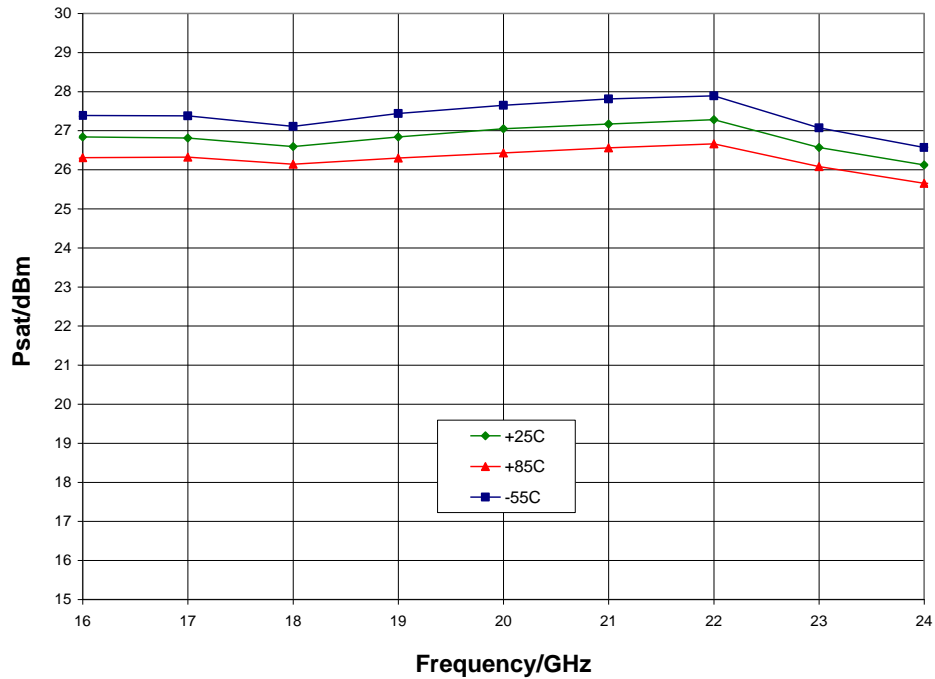

Psat vs. V_{dd} , $I_{dd} = 250\text{ mA}$, $T_A = 25^\circ\text{ C}$

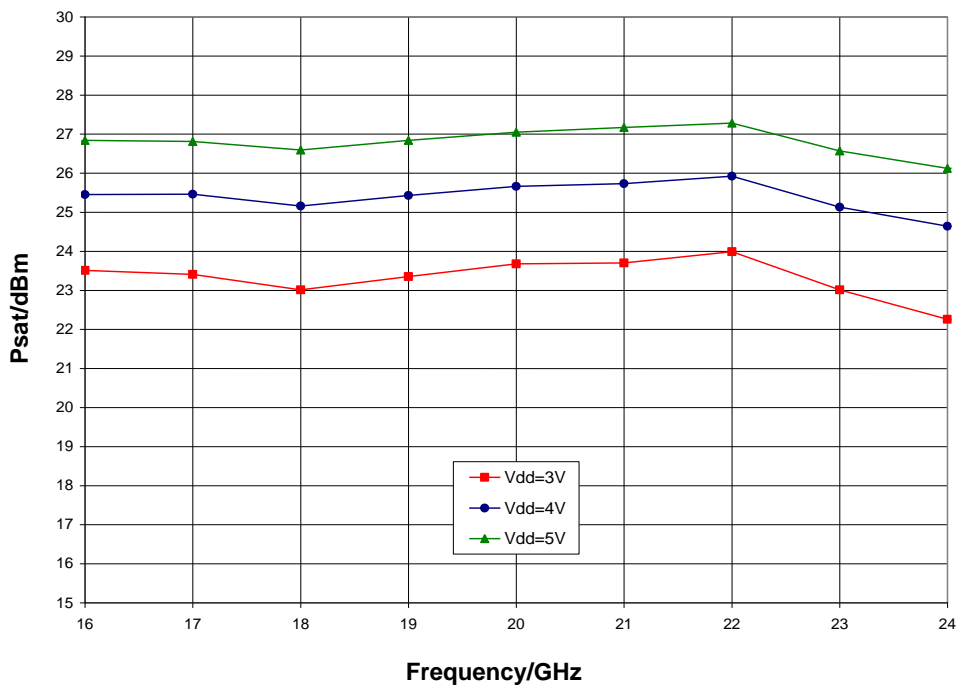

Typical Performance

Output IP3 vs. Temperature, $V_{dd} = 5\text{ V}$

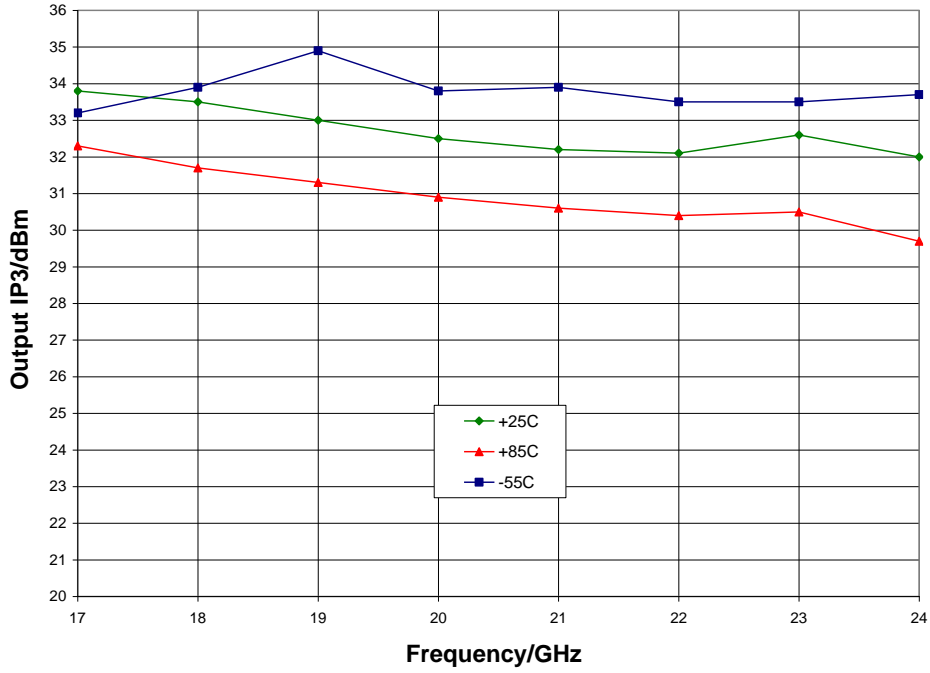

Output IP3 vs. V_{dd} , $I_{dd} = 250\text{ mA}$, $T_A = 25^\circ\text{C}$

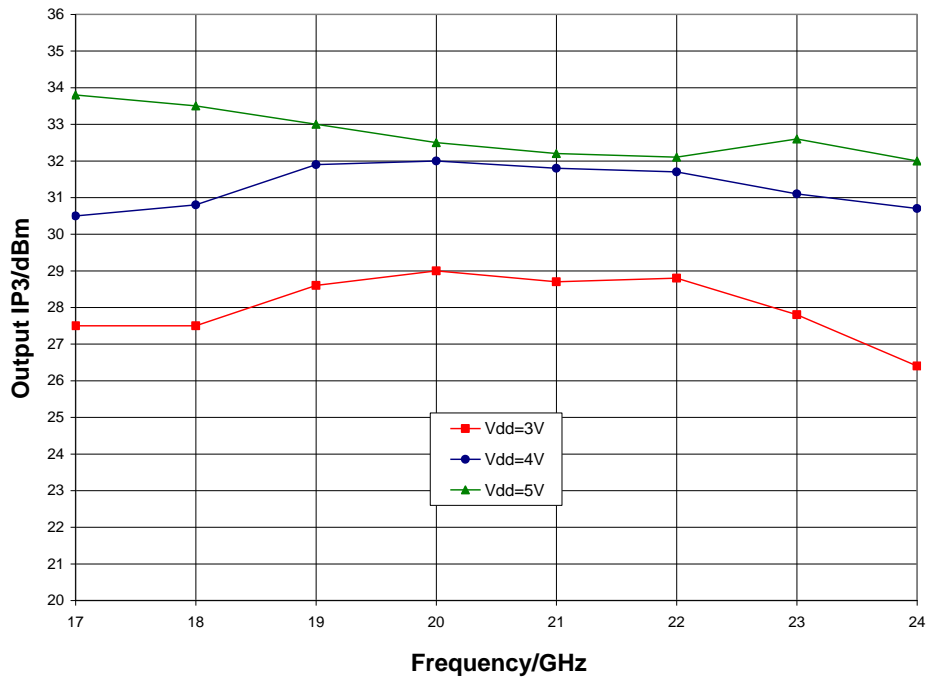

Mechanical Information

Die Outline (all dimensions in microns)

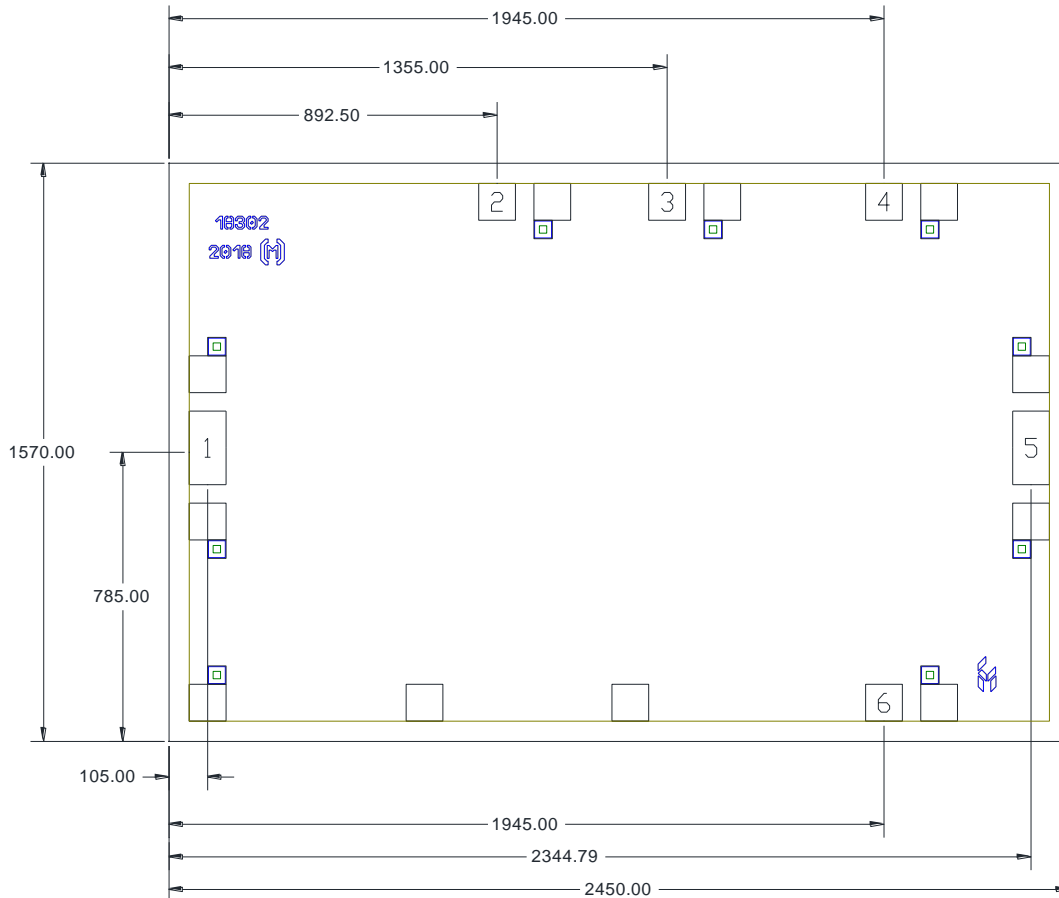

Notes:

1. No connection required for unlabeled pads
2. Backside is RF and DC ground
3. Backside and bond pad metal: Gold
4. Die is 70 microns thick
5. DC bond pads (2, 3, 4, 6) are 100 x 100 microns
6. RF bond pads (1, 5) are 100 x 200 microns

Pad Description

Pad Diagram

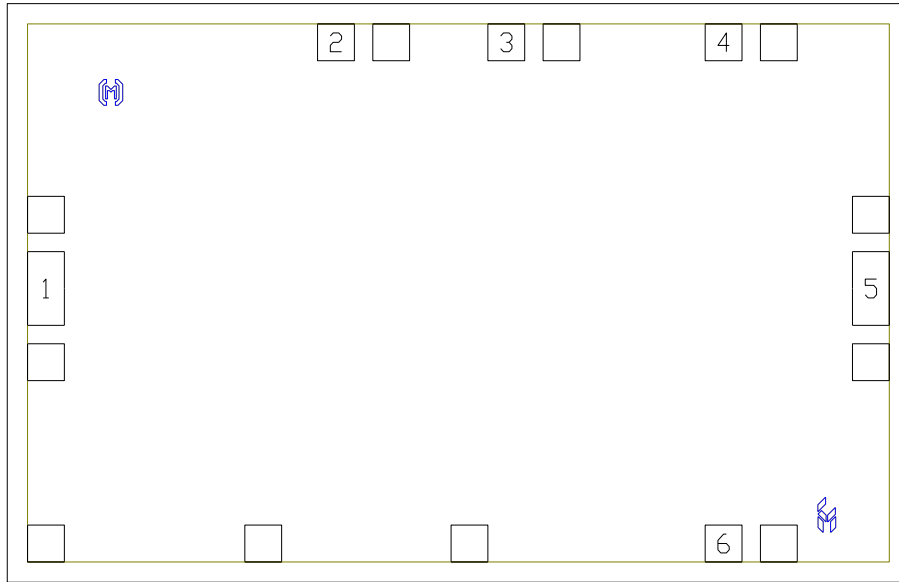

Functional Description

Pad	Function	Description	Schematic
1	RF in	DC blocked and 50 ohm matched	
2, 3, 4	V _{dd1, 2, 3}	Power supply voltage Decoupling and bypass caps required	
5	RF out	DC blocked and 50 ohm matched	
6	V _{gg}	Power supply voltage Decoupling and bypass caps required	
Backside	Ground	Connect to RF / DC ground	

Applications Information

Assembly Guidelines

The backside of the CMD291 is RF ground. Die attach should be accomplished with electrically and thermally conductive epoxy or eutectic attach. Standard assembly procedures should be followed for high frequency devices. The top surface of the semiconductor should be made planar to the adjacent RF transmission lines, and the RF decoupling capacitors placed in close proximity to the DC connections on chip.

RF connections should be made as short as possible to reduce the inductive effect of the bond wire. Use of a 0.8 mil thermosonic wedge bonding is highly recommended as the loop height will be minimized. The RF input and output require a double bond wire as shown.

The semiconductor is 70 μm thick and should be handled by the sides of the die or with a custom collet. Do not make contact directly with the die surface as this will damage the monolithic circuitry. Handle with care.

Assembly Diagram

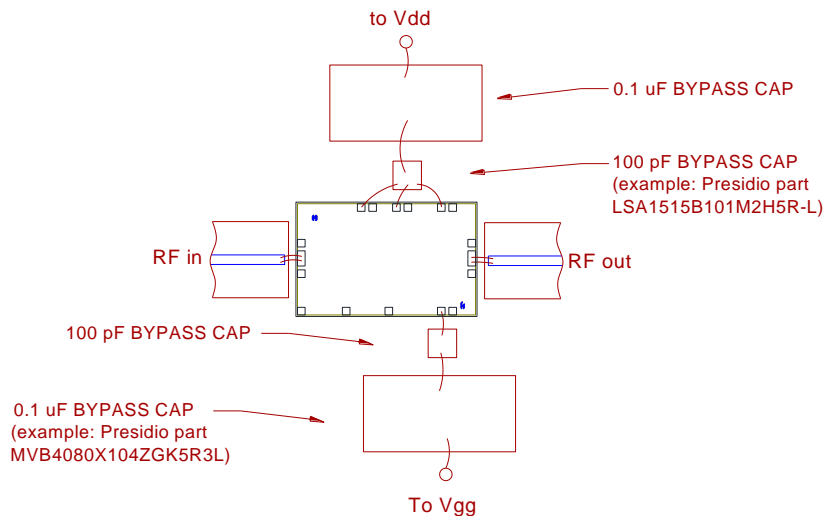

GaAs MMIC devices are susceptible to damage from Electrostatic Discharge. Proper precautions should be observed during handling, assembly and test.

Applications Information

Application Circuit

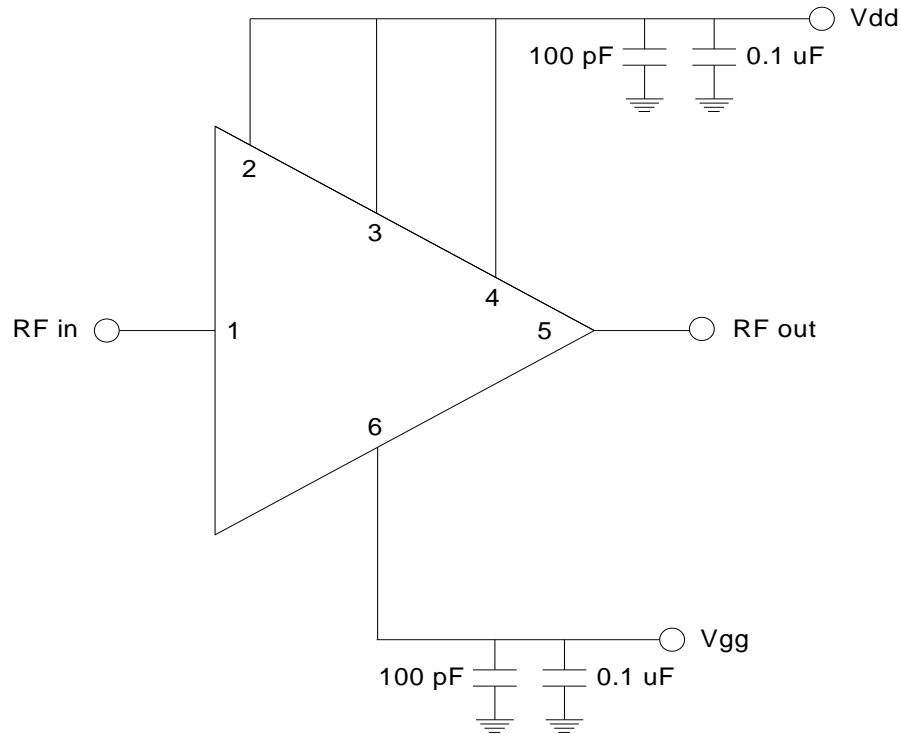

Biasing and Operation

The CMD291 is biased with a positive drain supply and a negative gate supply. Performance is optimized when the drain voltage is set to +5 V, though it may be set to as low as +3 V. The nominal gate voltage is -0.5 V.

Turn ON procedure:

1. Apply gate voltage V_{gg} and set to -2 V
2. Apply drain voltage V_{dd} and set to +5 V
3. Increase V_{gg} (less negative) to achieve a drain current of 250 mA

Turn OFF procedure:

1. Turn off drain voltage V_{dd}
2. Turn off gate voltage V_{gg}

For either approach, RF power can be applied at any time.