

Product Overview

The CMD303C3 is a sub-harmonically pumped mixer with an integrated LO amplifier housed in a leadless 3x3 mm surface mount QFN package. The CMD303C3 can be used as an upconverter or downconverter. The device has low conversion loss and excellent 2LO to RF isolation eliminating the need for additional filtering. The CMD303C3 requires as low as 0 dBm LO drive and operates on a single positive supply voltage. The sub-harmonic design and low LO drive level allows for less stringent oscillator requirements.

Functional Block Diagram

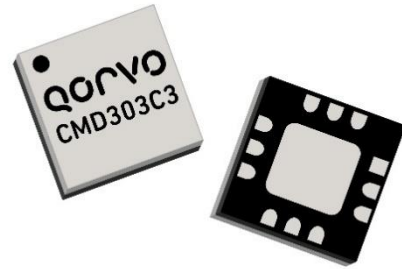
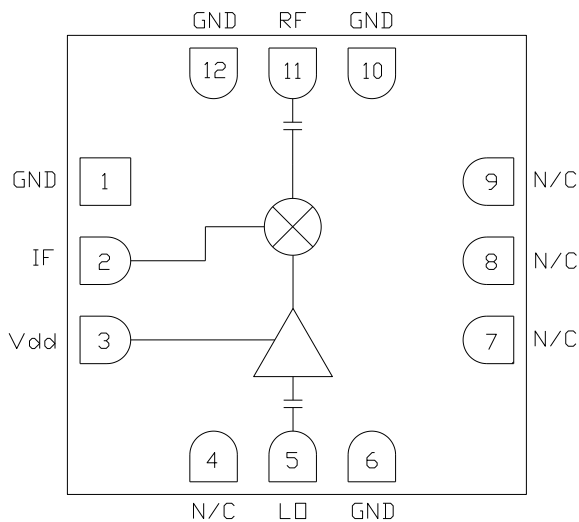

Key Features

- Integrated LO Amplifier
- High Isolations
- Sub-Harmonic x2 LO
- Single Positive Supply Voltage
- HMC258 Replacement

Ordering Information

Part No.	Description
CMD303C3	100 pcs on 7" reel
CMD303C3-EVB	Evaluation Board

Electrical Performance (V_{dd} = 3 V, IF = 100 MHz, LO = +2 dBm, RF = 18 GHz, T_A = 25° C)

Parameter	Min	Typ	Max	Units
Frequency Range, RF		13 - 21		GHz
Frequency Range, LO		6.5 - 10.5		GHz
Frequency Range, IF	DC		4	GHz
Conversion Loss		10		dB
Noise Figure (SSB)		10		dB
2LO to RF Isolation		22		dB
2LO to IF Isolation		43		dB
Input IP3		13		dBm
Input P1dB		4		dBm
Supply Current	22	32	42	mA

Unless otherwise noted, all measurements performed as a downconverter, IF = 100 MHz USB

Absolute Maximum Ratings

Parameter	Rating
RF / IF Input Power	+13 dBm
LO Drive	+8 dBm
Drain Voltage, V_{dd}	5.5 V
Channel Temperature, T_{ch}	150° C
Power Dissipation, P_{diss}	0.67 W
Thermal Resistance, Q_{JC}	97.2° C /W
Operating Temperature	-55 to 85° C
Storage Temperature	-55 to 150° C

Exceeding any one or combination of the maximum ratings may cause permanent damage to the device.

Recommended Operating Conditions

Parameter	Min	Typ	Max	Units
V_{dd}	2	3	5	V
I_{dd}		32		mA

Electrical performance is measured at specific test conditions. Electrical specifications are not guaranteed over all recommended operating conditions.

Electrical Specifications ($V_{dd} = 3$ V, $IF = 100$ MHz, $LO = +2$ dBm, $T_A = 25^\circ$ C)

Parameter	Min	Typ	Max	Min	Typ	Max	Units
Frequency Range, RF		13 - 17			17 - 21		GHz
Frequency Range, LO		6.5 - 8.5			8.5 - 10.5		GHz
Frequency Range, IF		DC - 4			DC - 4		GHz
Conversion Loss		9.5	13		10	13.5	dB
Noise Figure (SSB)		9.5			10		dB
2LO to RF Isolation	14	20		19	22		dB
2LO to IF Isolation	33	43		39	47		dB
Input IP3		13			9		dBm
Input P1dB		3			3		dBm
Supply Current	22	32	42	22	32	42	mA

Unless otherwise noted, all measurements performed as a downconverter, $IF = 100$ MHz USB

Typical Performance

Conversion Gain vs. Temperature, LO = +2 dBm, IF = 100 MHz USB

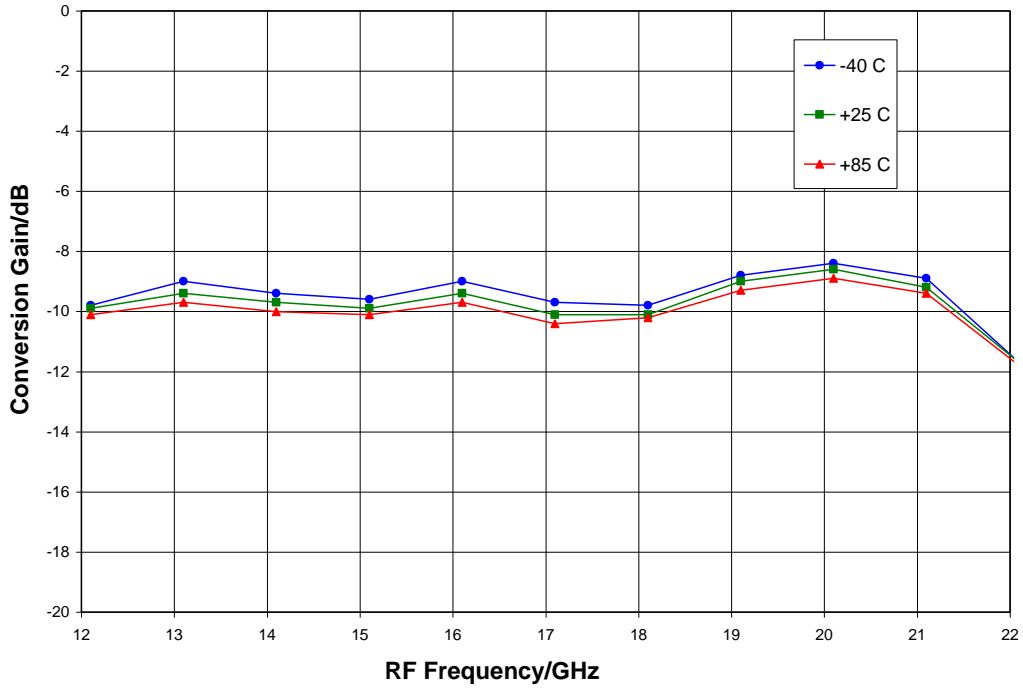

Conversion Gain vs. LO Drive, IF = 100 MHz USB, T_A = 25° C

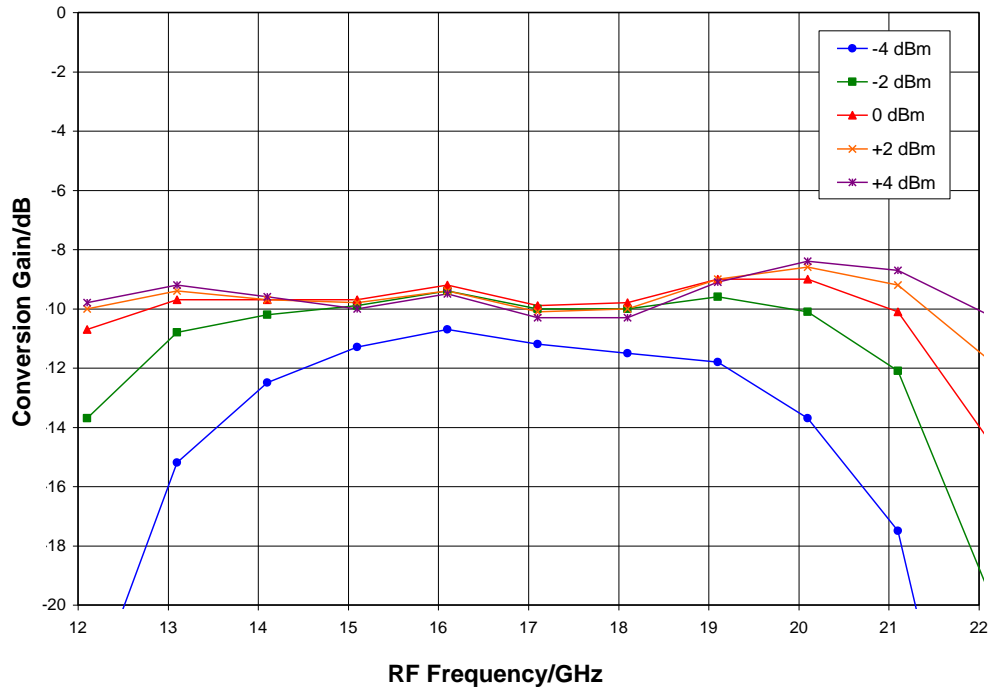

Typical Performance

Isolations, LO = +2 dBm, RF = -10 dBm, T_A = 25° C

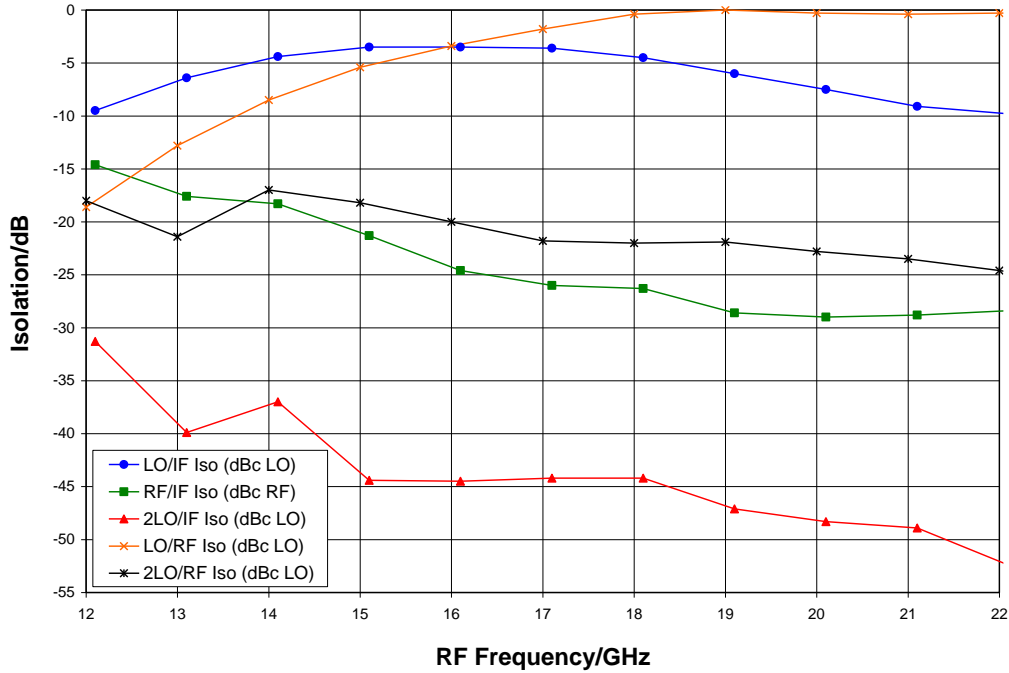

Return Loss, LO = +2 dBm, T_A = 25° C

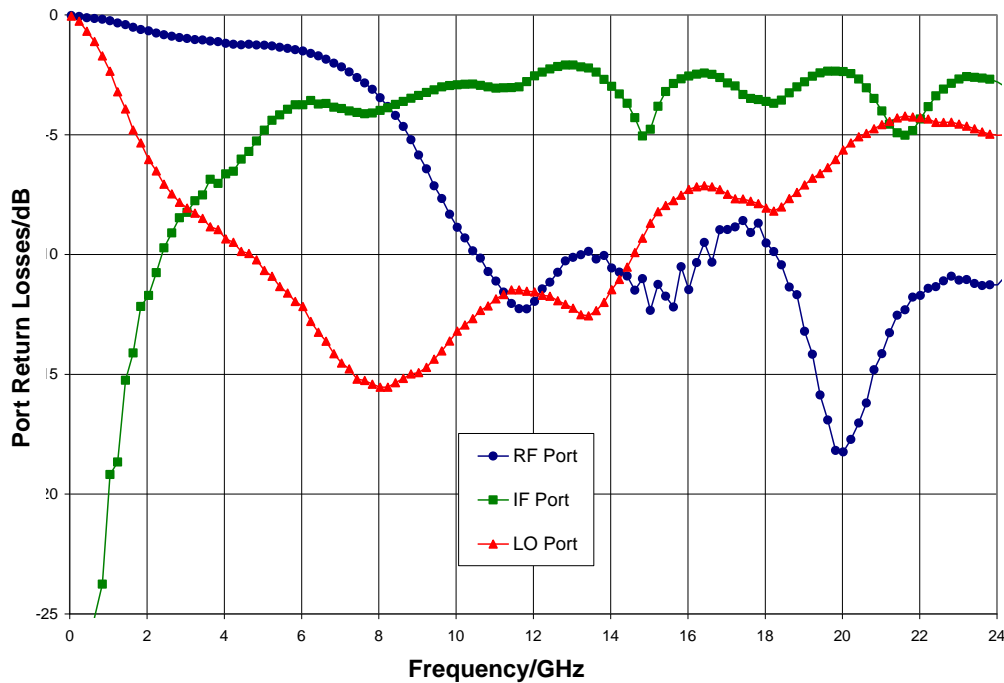

Typical Performance

IF Bandwidth, LO = +2 dBm, T_A = 25° C

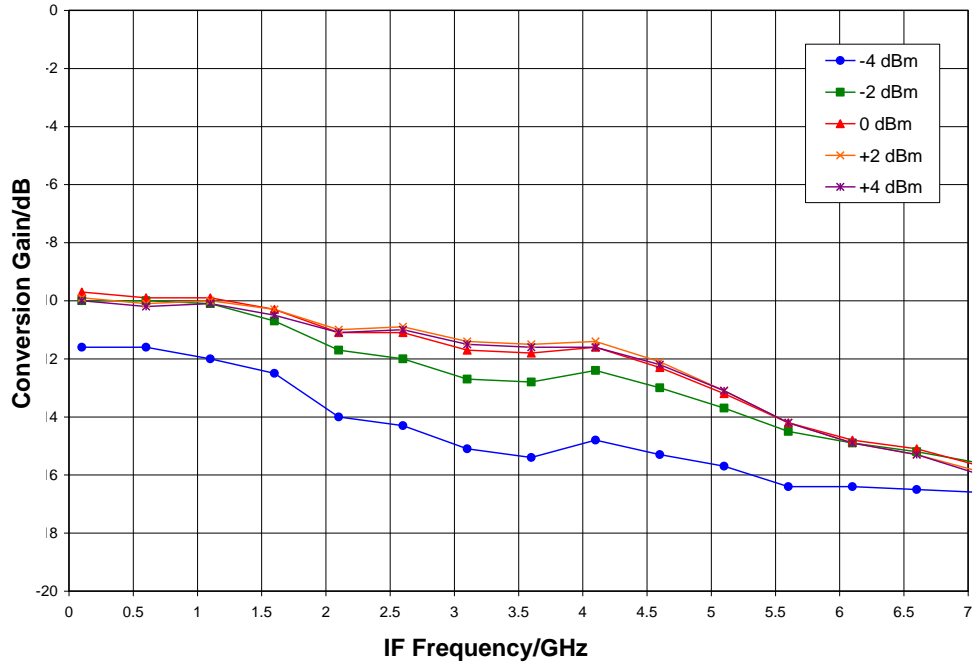

Upconverter Performance, Conversion Gain vs. LO Drive, T_A = 25° C

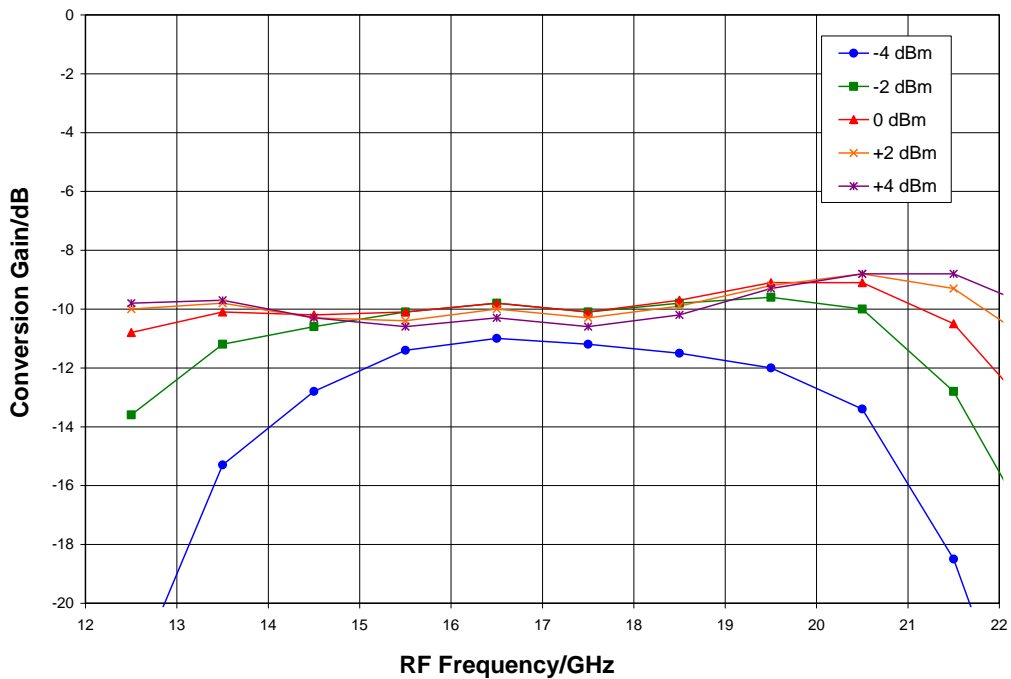

Typical Performance

Input IP3 vs. Temperature, LO = +2 dBm

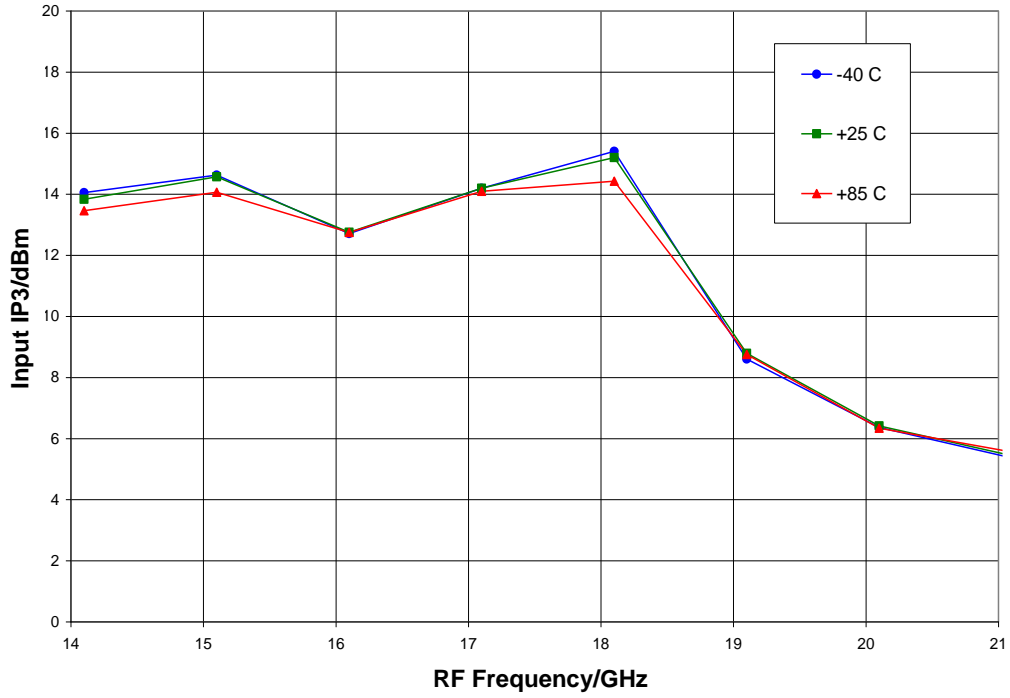

Input IP3 vs. LO Drive, T_A = 25° C

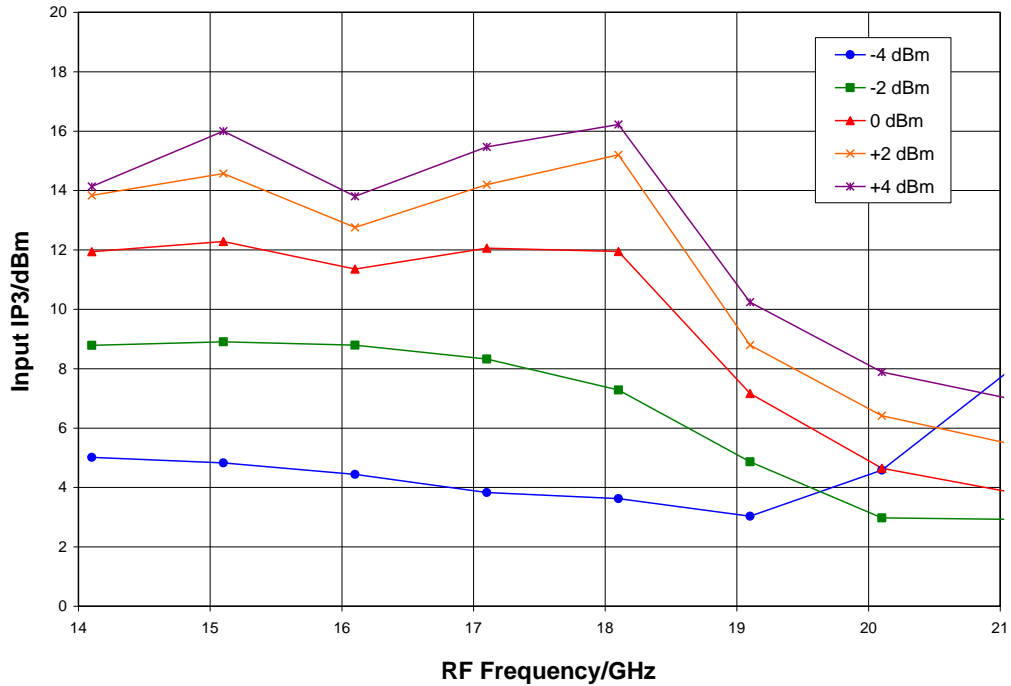

Typical Performance

Input P1dB vs. Temperature, LO = +2 dBm

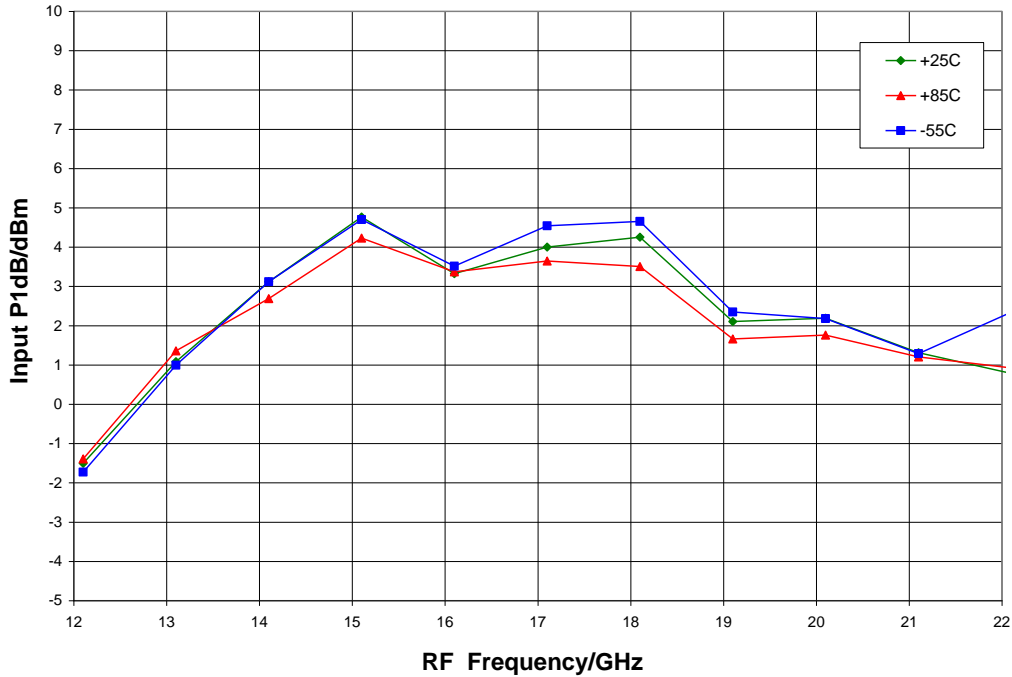

MxN Spur Table

mRF	nLO				
	0	1	2	3	4
0	X	-9	38	31	61
1	18	31	0	35	41
2	76	60	60	32	45
3	76	76	76	76	68
4	-14	76	76	76	76

RF = 18 GHz @ -10 dBm
 LO = 8.55 GHz @ 0 dBm
 All values in dBc below the IF output power level (1RF - 2LO)

Mechanical Information

Package Information and Dimensions

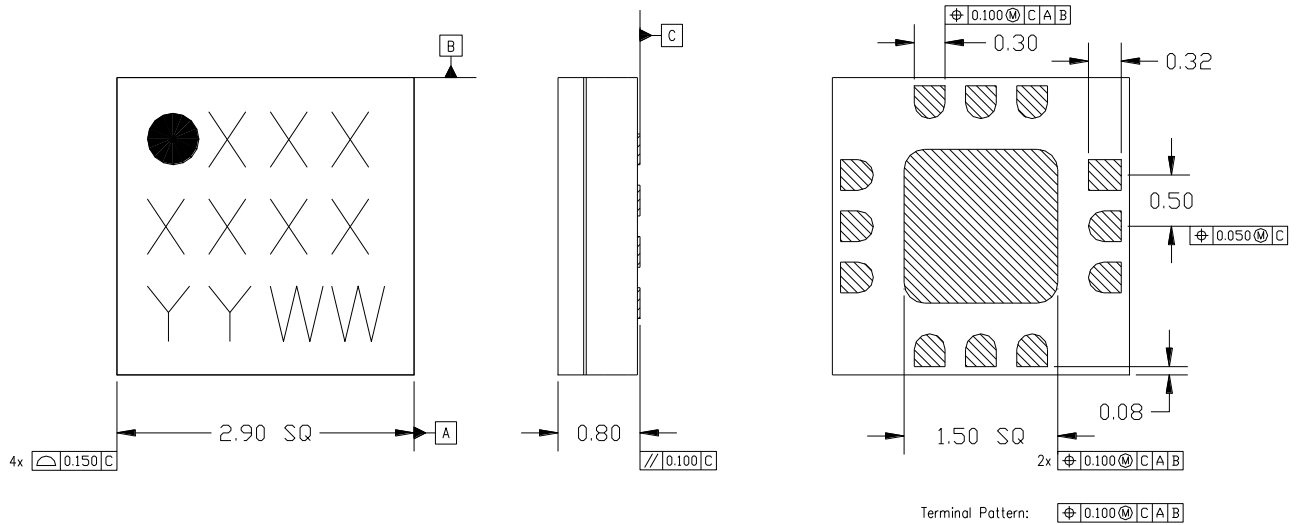

Notes:

1. All dimensions shown in mm.
2. Material: Black alumina
3. Lead finish:
 - 3.1. Ni: 8.89um max, 1.27um min
 - 3.2. Pd: 0.17um max, 0.07um min
 - 3.3. Au: 0.254um max, 0.03um min
4. Marking
 - 4.1. Line 1: Part number
 - 4.1.1. Example: CMD177C3 shall be marked as 177
 - 4.2. Line 2: Lot number
 - 4.3. Line 3: Date code - Last 2 digits of the year of manufacture followed by a 2 digit week code
5. Alternate pin #1 identifier is a single square pad
6. Alternate die paddle may have chamfered corners

Recommended PCB Land Pattern

Qorvo recommends that the user develop the land pattern that will provide the best design for proper solder reflow and device attach for their specific application. Please review Qorvo Application Note AN 105 for a recommended land pattern approach.

Recommended Solder Reflow Profile

Qorvo recommends screen printing with belt furnace reflow to ensure proper solder reflow and device attach. Please review Qorvo Application Note AN 102 for a recommended solder reflow profile.

Pin Description

Pin Diagram

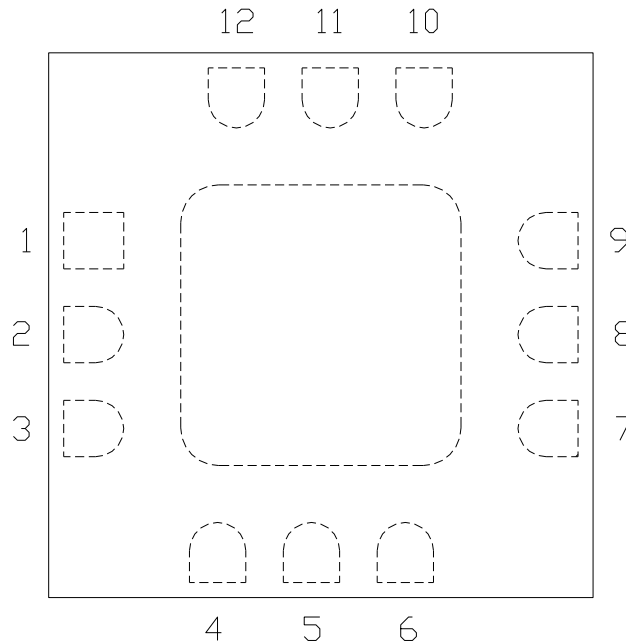

Functional Description

Pin	Function	Description	Schematic
2	IF	This pin is DC coupled and should be DC blocked externally using a series capacitor whose value has been chosen to pass the necessary IF frequency. Any applied DC voltage to this pin will result in die non-function and possible die failure.	
3	V _{dd}	Power supply voltage Decoupling and bypass caps required	
4, 7 - 9	N/C	No connection required These pins may be connected to RF / DC ground	
5	LO	DC blocked and 50 ohm matched	
11	RF	DC blocked and 50 ohm matched	
1, 6, 10, 12 and die paddle	Ground	Connect to RF / DC ground	

Applications Information

Evaluation Board

The circuit board shown has been developed for optimized assembly at Qorvo. A sufficient number of via holes should be used to connect the top and bottom ground planes. As surface mount processes vary, careful process development is recommended.

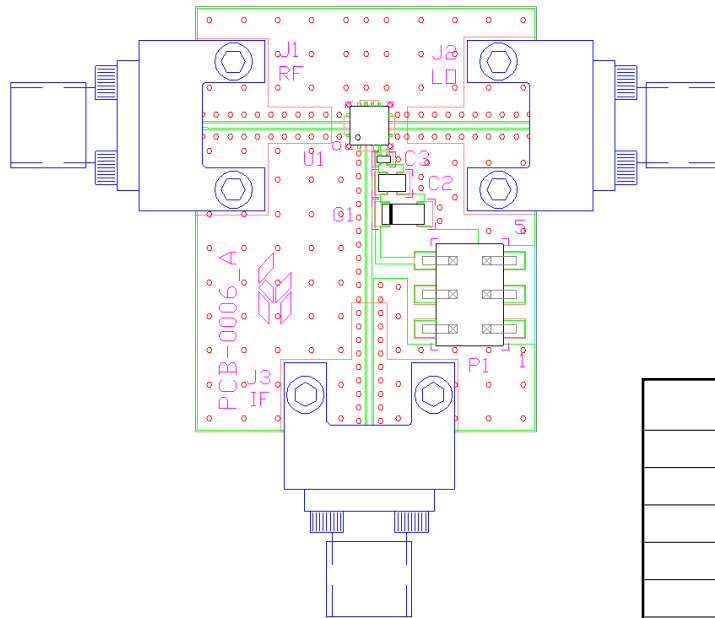

P1	DESCRIPTION
1	GND
2	N/C
3	N/C
4	N/C
5	GND
6	Vdd

Bill of Material

Designator	Value	Description
J1 - J3		2.92 mm End Launch Connector
P1		6 Pin Header
C1	0.33 μ F	Capacitor, Tantalum
C2	1000 pF	Capacitor, 0603
C3	100 pF	Capacitor, 0402
U1		CMD303C3 Sub-harmonic x2 Mixer
PCB		DRAW-PCB-0006 Evaluation PCB

GaAs MMIC devices are susceptible to damage from Electrostatic Discharge. Proper precautions should be observed during handling, assembly and test.