

REV.	REVISION DESCRIPTION	APP.	DRW.	DATE	CHANGE No.
X 5	Housing design change, Add Note.1	K.A	K.A	03/17/09	
X					
X					

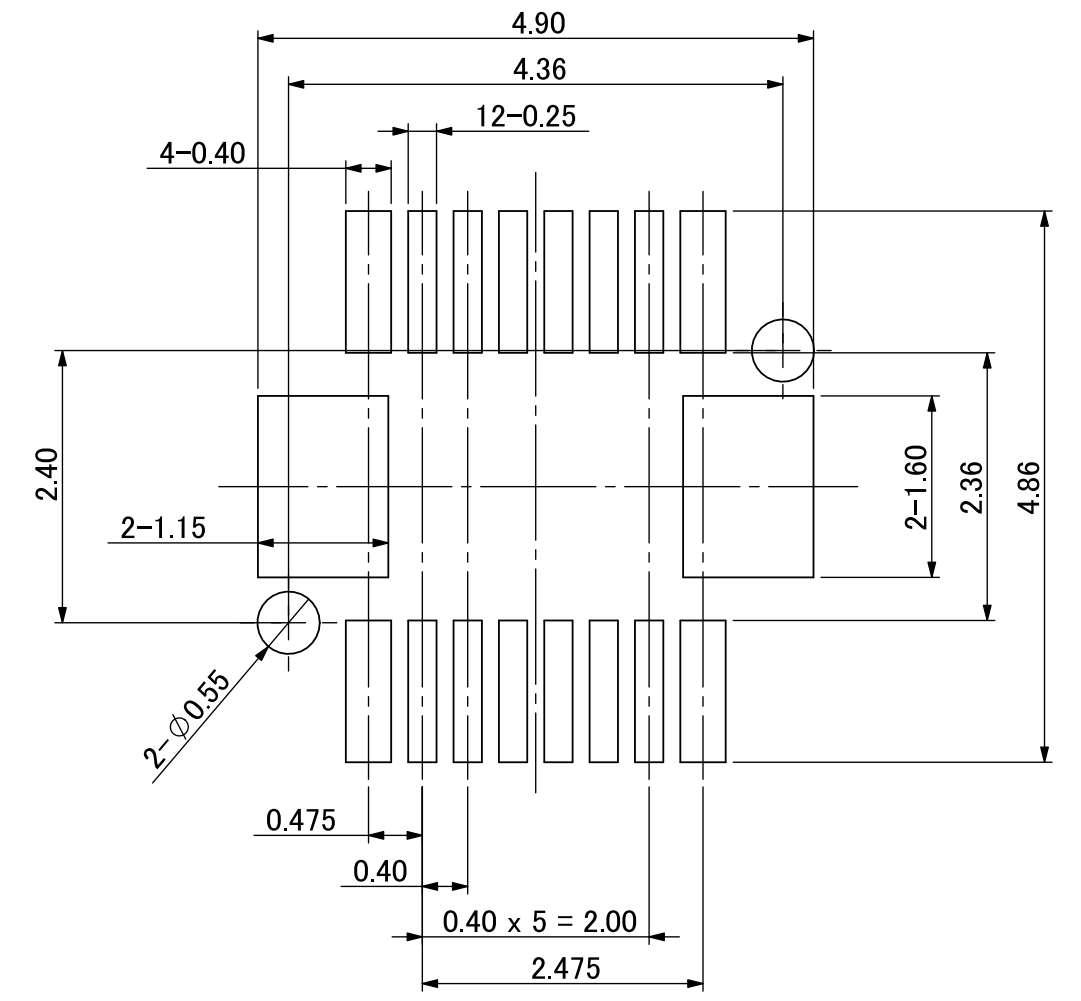
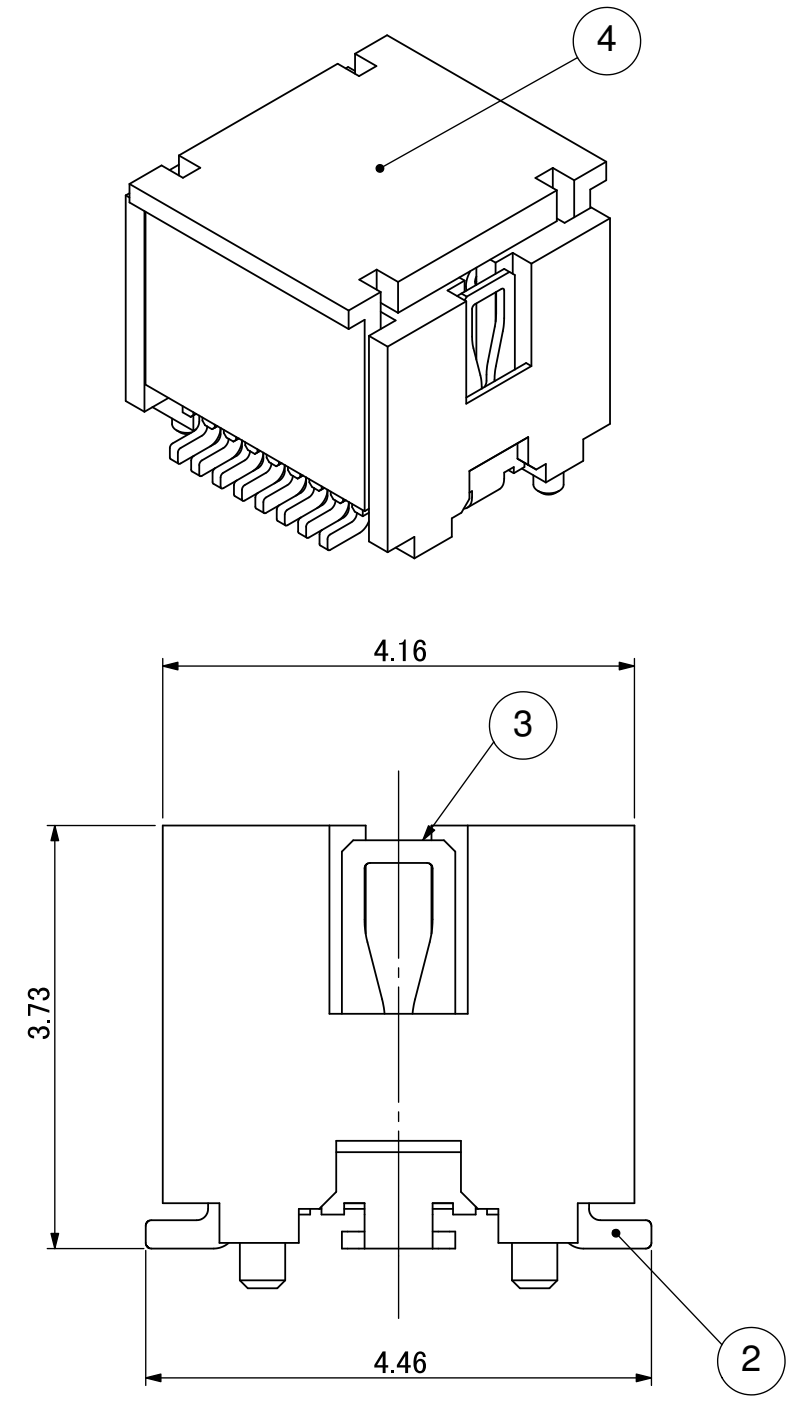
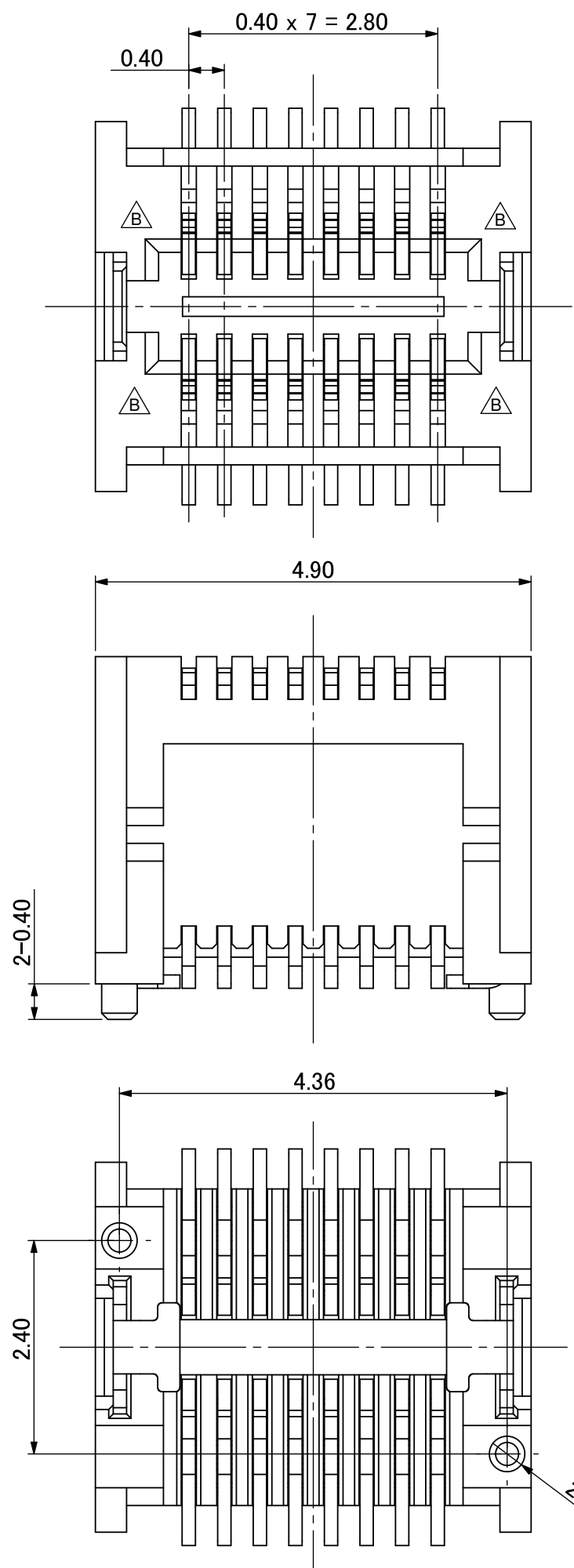

Recommended PCB Layout
Tolerance ± 0.05

Note.
B 1. Recommended solder paste thickness: 0.08mm

Item No.	Description	Qty.	Material	Content
4	Pick & Place Cap	1	LCP	Black
3	Lock Metal Parts	2	PB, t=0.15	Ni-Tin
2	Contact Pin	16	PB, t=0.15	Ni-Au
1	Insulator	1	LCP	Black

Tolerance ± 0.25 Unless otherwise specified						YAMAICHI ELECTRONICS USA INC.				
Sierra Wireless						CLASS 0.40mm Pitch, BtoB Connector, Socket				
SCALE	15 / 1	APP.	APP.	CHK.	DRW.	DSGN.	Part # CNU010S-016-0001			
DIMENSION	mm		01/27/09	01/27/09	01/27/09	01/27/09	DRW No. YEU-A1131			
ANGLE PROJ	3rd		T. Nishimura	T. Nishimura	K. Abe	K. Abe	Sheet No. /		REV. B	