

	REVISION DESCRIPTION	APP.	DRW.	DATE	CHANGE No.
△x					
△x					
△x					

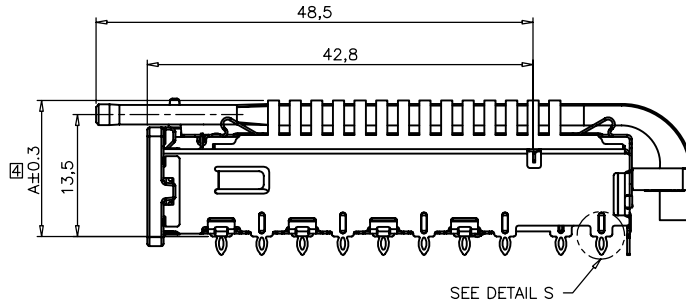

SEE DETAIL S

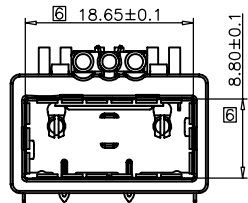
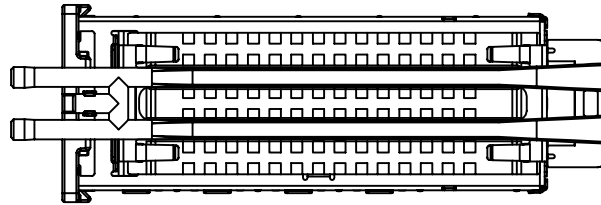
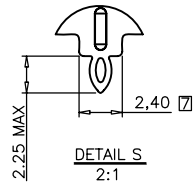
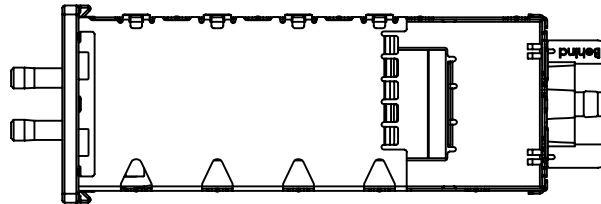

1. MATERIALS:
 CAGE ASSEMBLY: COPPER ALLOY, 0.25 THICKNESS
 EMI SPRING: STAINLESS STEEL
 FRONT FLANGE: ZINC ALLOY
 HEAT SINK: ALUMINUM
 HEAT SINK CLIP: STAINLESS STEEL
 LIGHT PIPE MATERIAL: CLEAR POLYCARBONATE
2. SPACING BETWEEN GAGES ON THE SAME PC BOARD, TO BE SPECIFIED BY CUSTOMER, MUST COMPLY WITH MINIMUM DIMENSIONS SHOWN.
3. DIMENSION F IS THE NOMINAL THICKNESS OF CUSTOMER SUPPLIED PC BOARD.
 MINIMUM SINGLE SIDED PC BOARD THICKNESS: 1.45mm
 MINIMUM DOUBLE SIDED PC BOARD THICKNESS: 2.7mm PER QSFP
4. DIMENSION APPLIES WITH MODULE INSERTED IN CAGE.
5. MATES WITH QSFP MSA COMPATIBLE TRANSCEIVER.
6. INSIDE SURFACE OF CASSETTE WHEN FULLY COMPRESSED.
7. SURFACE TRACES PERMITTED WITHIN THIS AREA EXCEPT WHERE CAGE STANDOFFS, SHOWN IN DETAIL S CONTACT PC BOARD.
8. EMI SPRING FINISH: CLEAR PASSIVATION
 FRONT FLANGE FINISH: OVER 8um MIN COPPER, OVER 8um MIN NICKEL
 HEAT SINK FINISH: CLEAR PASSIVATION
 HEAT SINK CLIP FINISH: CLEAR PASSIVATION
9. CAGE BASED ON STD. SFF-8436 Rev 3.5.
10. THIS PRODUCT COMPLY TO ROHS DIRECTIVE 2002/95/EC.
11. DATUM X & Y ARE ESTABLISHED BY THE CUSTOMER'S FIDUCIAL
12. DATUM A IS THE TOP SURFACE OF THE HOST BOARD
13. LOCATION OF THE EDGE OF PCB IS APPLICATION SPECIFIC
14. BASELINE FOR THESE DIMENSIONS IS THE CENTER OF COMPLIANT PIN HOLE.
15. FINISHED HOLE SIZE
16. UNPLATED THRU HOLE.
17. CENTERLINE OF PAD
18. SURFACE TRACES PERMITTED WITHIN THIS LENGTH

UNITS:		
<input checked="" type="checkbox"/>	MM	<input type="checkbox"/> INCH
GENERAL TOLERANCES: UNLESS SPECIFIED		
	MM	INCH
4 PLACE	±**	±**
3 PLACE	±0.1	±**
2 PLACE	±0.2	±**
1 PLACE	±0.3	±**
ANGULAR	X°±2'	X°±1'

22.1	NETWORKING	CNU120A-10-40-30	YEU-A1944
15.1	SAN	CNU120A-10-30-30	YEU-A1943
12.8	PCI	CNU120A-10-20-30	YEU-A1942
A	HEAT SINK PROFILE	PART No.	DWG No.

SCALE 2/1						CLASS DSFP Cage Assembly					
DIMENSION mm						TITLE CNU120A-10-**-30					
ANGLE PROJ 3rd						DRW No. YEU-A1929					
APP. / CHK. / DRW. / DSGN.						Sheet No. 1/4					
APP. / CHK. / DRW. / DSGN.						REV. A					



YAMAICHI ELECTRONICS
USA INC.

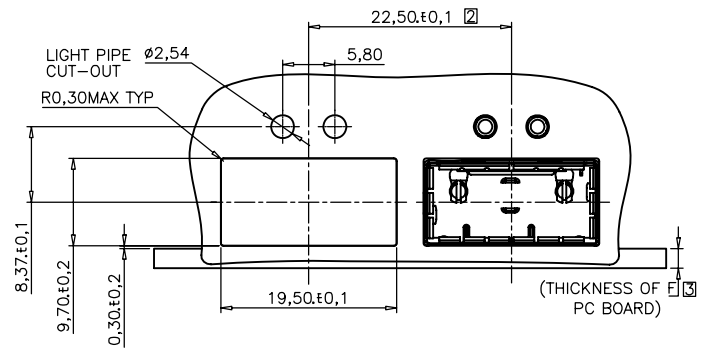

RECOMMENDED SINGLE SIDE MOUNTING BEZEL DESIGN

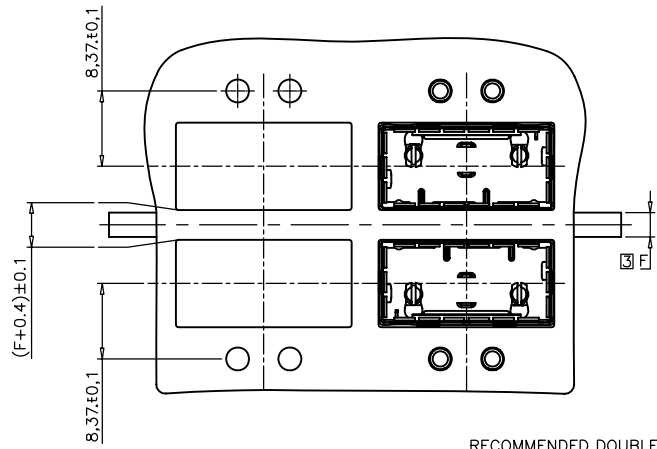
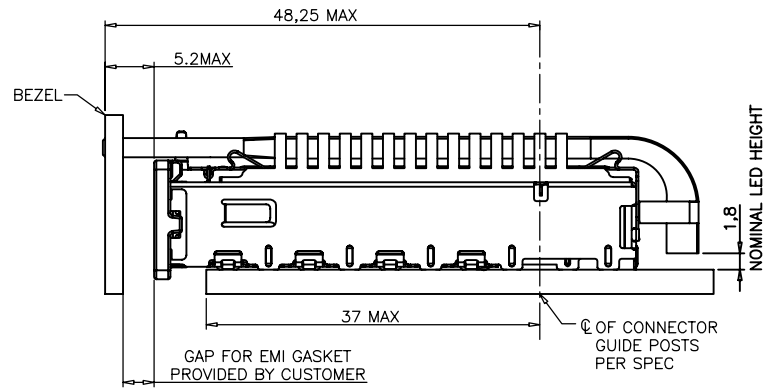

RECOMMENDED DOUBLE SIDE MOUNTING BEZEL DESIGN

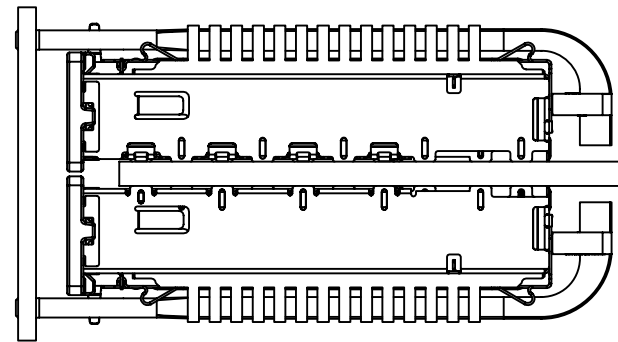

UNITS:
 ■ MM □ INCH

GENERAL TOLERANCES:
 UNLESS SPECIFIED

	MM	INCH
4 PLACE	±**	±**
3 PLACE	±0.1	±**
2 PLACE	±0.2	±**
1 PLACE	±0.3	±**
ANGULAR	X°±2°	X°±1°

SCALE 2/1						APP.		APP.	CHK.	DRW.	DSGN.	YAMAICHI ELECTRONICS USA INC. CLASS DSFP Cage Assembly TITLE CNU120A-10-**-30 DRW No. YEU-A1929	Sheet No.	REV.
DIMENSION mm						07/02/12		07/02/12	07/02/12	07/02/12	07/02/12		2/4	A
ANGLE PROJ 3rd						K. Abe		K. Abe	Shimizu	Shimizu				

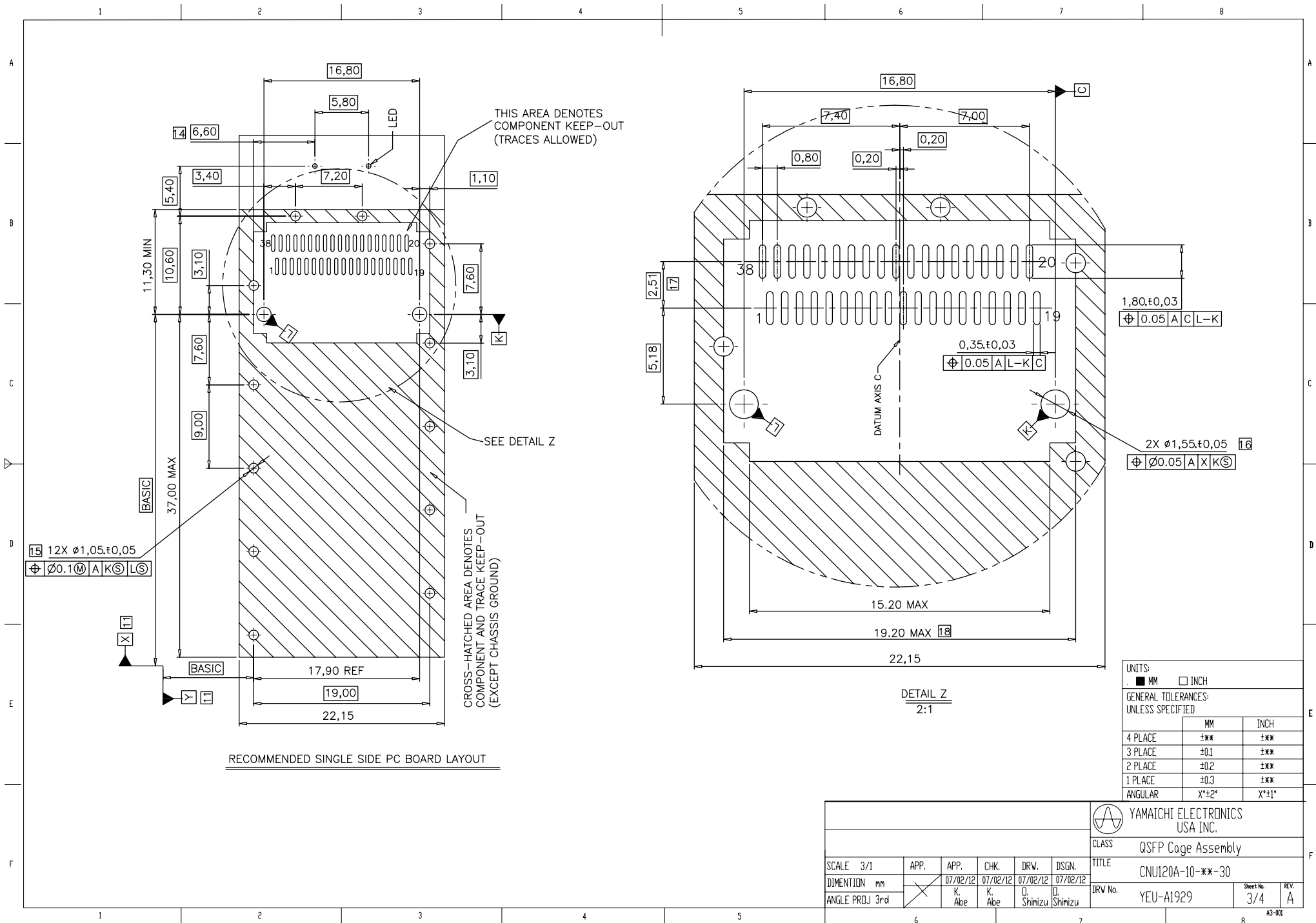

RECOMMENDED SINGLE SIDE PC BOARD LAYOUT

DETAIL Z
2:1

UNITS:
 ■ MM □ INCH

GENERAL TOLERANCES:
 UNLESS SPECIFIED

	MM	INCH
4 PLACE	±**	±**
3 PLACE	±0.1	±**
2 PLACE	±0.2	±**
1 PLACE	±0.3	±**
ANGULAR	X°±2'	X°±1'

						CLASS QSFP Cage Assembly		
						TITLE CNU120A-10-**-30		
SCALE 3/1	APP.	APP. K. Abe	CHK. K. Abe	DRW. I. Shimizu	DSGN. I. Shimizu	DRW No. YEU-A1929	Sheet No. 3/4	REV. A
DIMENSION mm						ANGLE PROJ 3rd		43-001