



CON292003

2.92 mm Jack PCB Compression Surface-Mount Connector

The CON292003 is a 2.92 mm jack (female socket) PCB solderless surface-mount connector designed for installation directly to a printed circuit board using the provided split washers and screws.

Operating from 0 Hz to 40 GHz, the CON292003 combines superior performance, compact size, and a convenient threaded mating interface to provide a reliable, easy-to-use connector. Additionally, all Linx connectors meet RoHS lead free standards and are tested to meet requirements for corrosion resistance, vibration, mechanical and thermal shock.

FEATURES

- 0 Hz to 40 GHz operation
- Nickel plated brass body for superior corrosion resistance
- Gold plated beryllium copper center contact
- All mounting hardware is passivated stainless steel
 - 2x split washers
 - 2x pan-head screws
- Direct PCB attachment
- Solderless compression-mount design

APPLICATIONS

- Satellite communications
- Test and measurement
- Radar
- Experimental

TABLE 1. ELECTRICAL SPECIFICATIONS

Parameter	Value
Impedance	50 Ω
Frequency Range	0 Hz to 40 GHz
Dielectric Withstanding Voltage	750 V RMS
Contact Resistance	Center: ≤ 3.0 m Ω Outer: ≤ 2.0 m Ω
Insulation Resistance	5000 M Ω min.
Insertion Loss (dB max)	0.1
VSWR (max)	1.1

ORDERING INFORMATION

Part Number	Description
CON292003	2.92 mm jack (female socket) PCB solderless surface-mount connector with split washers and pan-head 0-80UNF-2A screws

Available from Linx Technologies and select distributors and representatives.

PRODUCT DIMENSIONS

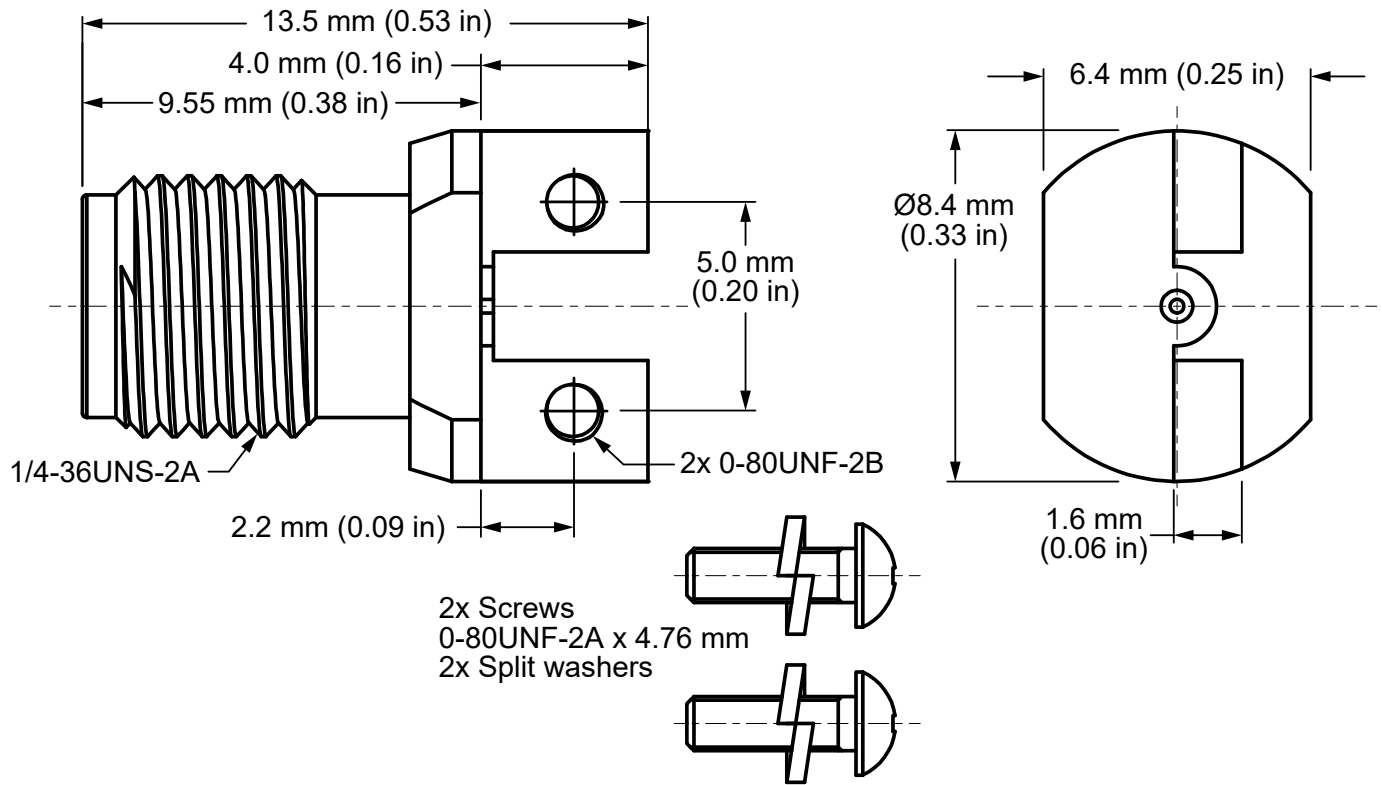

Figure 1: Product Dimensions for the CON292003 Connector

TABLE 2. CONNECTOR COMPONENTS

Model	CON292003	
Connector Part	Material	Finish
Connector Body	Brass	Nickel
Center Contact (female socket)	Beryllium Copper	Gold
Split Washer (2x)	Stainless Steel	Passivated
Screw, PHP (2x) 0-80UNF-2A	Stainless Steel	Passivated

RECOMMENDED PCB FOOTPRINT

Figure 2 shows the connectors recommended PCB footprint and mounting requirements. The printed circuit board thickness should be no more than 2 mm thick. The provided split washers and screws should be tightened to a torque setting not to exceed 0.09N:m (12 in-oz).

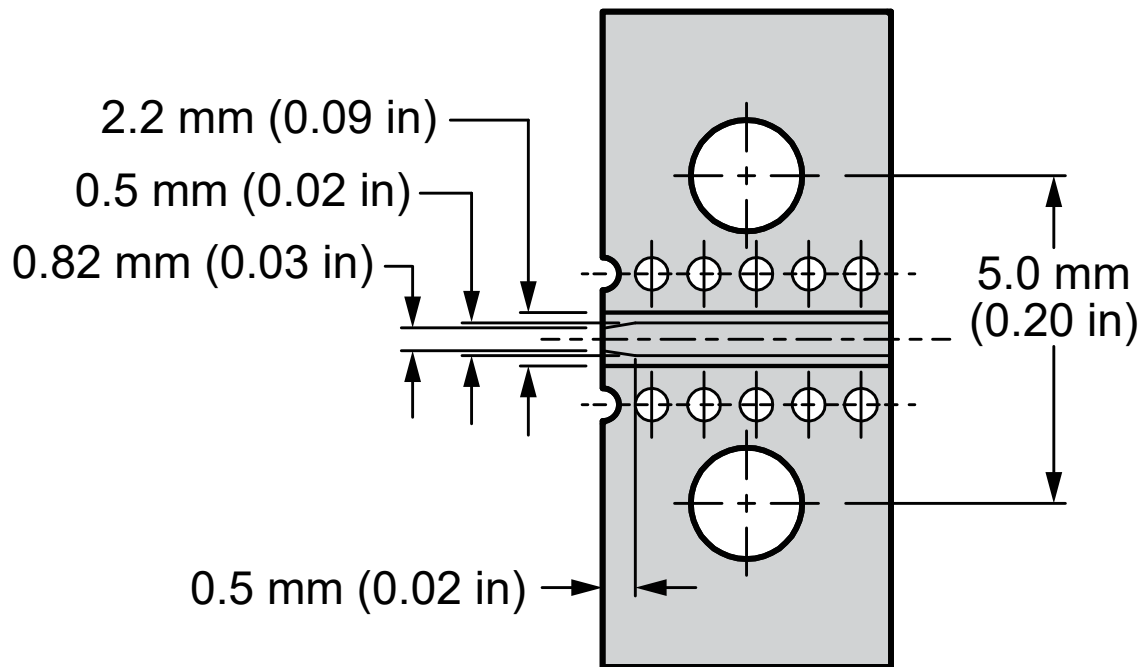

Figure 2: Recommended PCB Dimensions for the CON292003

TABLE 3. MECHANICAL SPECIFICATIONS

Model	CON292003
Mounting Type	Solderless PCB end-launch design
Fastening Type	1/4-36UNS Threaded Coupling
Interface in Accordance with	MIL-STD-348B
Connector Durability	500 cycles min.
Recommended torque	8.0 in. -lbs
Weight	2.2 g (0.08 oz)

INSERTION LOSS

Figure 3 shows the Insertion Loss for the CON292003 connector. Insertion loss is the loss of signal power (gain) resulting from the insertion of a device in a transmission line.

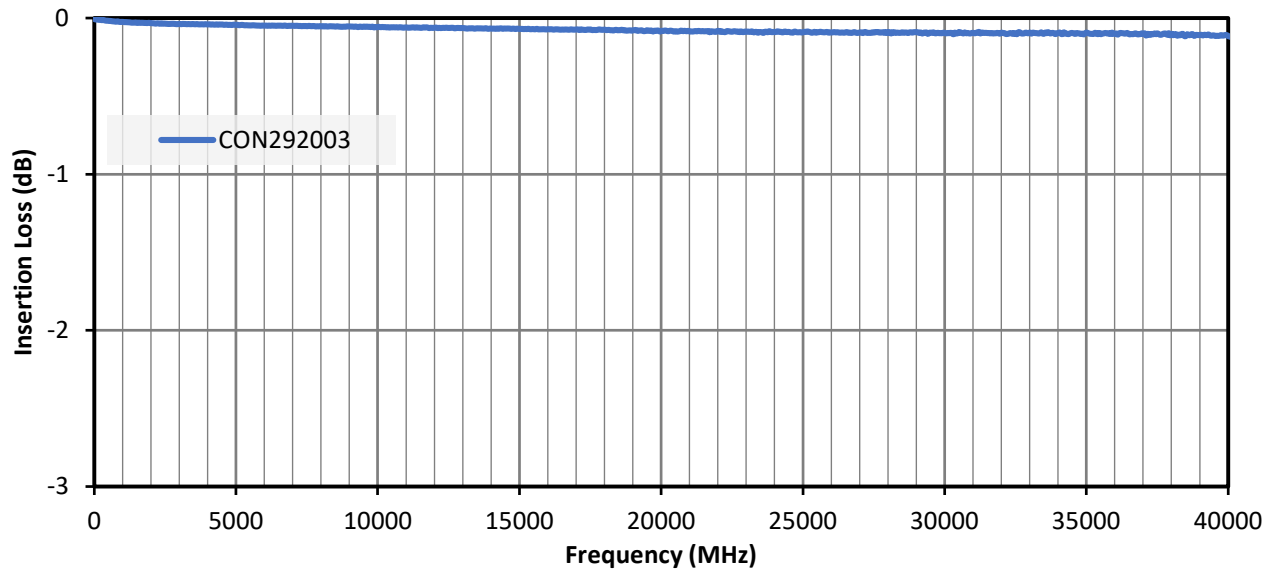

Figure 3: Insertion Loss for the CON292003 Connector

VSWR

Figure 4 provides the voltage standing wave ratio (VSWR) across the adapter's bandwidth for the CON292003 connector. VSWR describes how efficiently power is transmitted. A lower VSWR value indicates better performance at a given frequency.

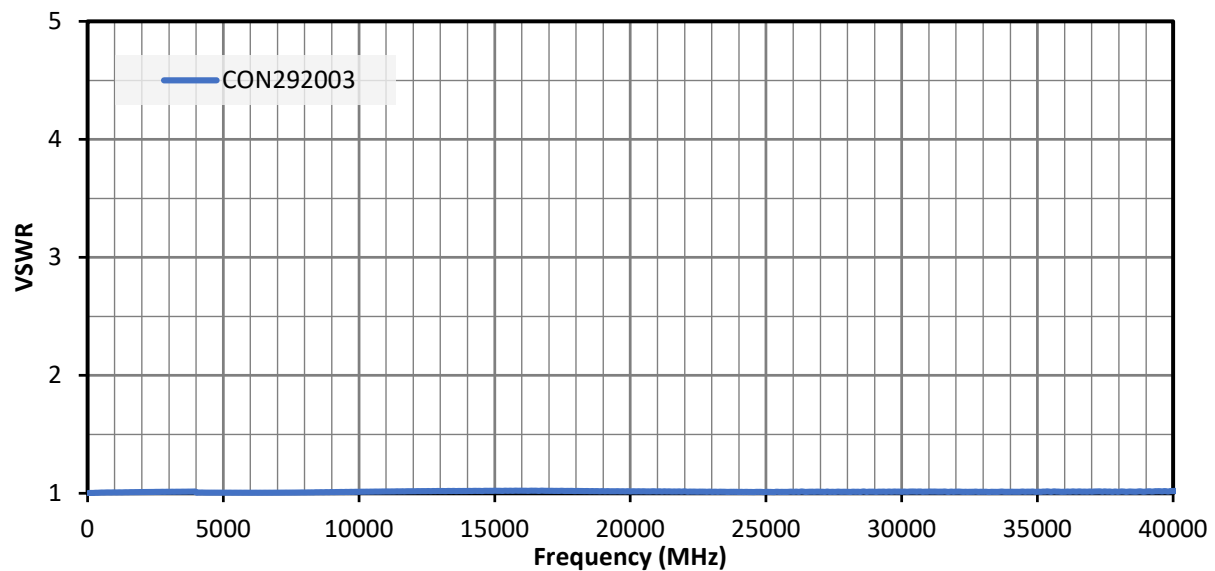

Figure 4: VSWR for the CON292003 Connector