



## CONSPA020.042-G

### SMP Plug PCB Through-Hole Connector

The CONSMP001-2-G is an SMP plug limited detent PCB through-hole connector designed for reflow- solder mounting directly to a printed circuit board.

Operating from 0 GHz to 40 GHz, the CONSMP001- 2-G combines superior performance, compact size, and a convenient snap-on mating interface to provide a reliable, easy-to-use connector. Linx SMP connectors are ideal for making board-to-board connections. Additionally, all Linx connectors meet RoHS lead free standards and are tested to meet requirements for corrosion resistance, vibration, mechanical and thermal shock.

#### FEATURES

- 0 to 40 GHz operation
- SMP plug (male pin) connection
  - Gold plated beryllium copper center contact
  - Limited detent
- Ideal for board-to-board connections
- Direct PCB attachment
- Reflow- or hand-solder assembly

#### APPLICATIONS

- Cellular IoT
  - LTE-M (Cat-M1), NB-IoT
- Cellular
  - 5G/4G LTE/3G/2G
- WiFi/WLAN
  - WiFi 6/6E
- GNSS
  - GPS, Galileo, GLONASS, BeiDou, QZSS
- Radar, Satellite Communications, Experimental
- Industrial, Commercial, Enterprise

#### TABLE 1. ELECTRICAL SPECIFICATIONS

Parameter	Value	
Impedance	50 $\Omega$	
Frequency Range	0 to 40 GHz	
Voltage Rating	500 V RMS	
Contact Resistance	Center: $\leq 6.0$ m $\Omega$ Outer: $\leq 2.0$ m $\Omega$	
Select Frequencies	0 GHz to 26.5 GHz	26.5 GHz to 40 GHz
Insertion Loss (dB max.)	1.07	1.22
VSWR (max.)	1.5	1.4

## ORDERING INFORMATION

Part Number	Description
CONSMPO01-2-G	SMP plug (male pin) limited detent PCB through-hole connector

Available from Linx Technologies and select distributors and representatives.

## PRODUCT DIMENSIONS

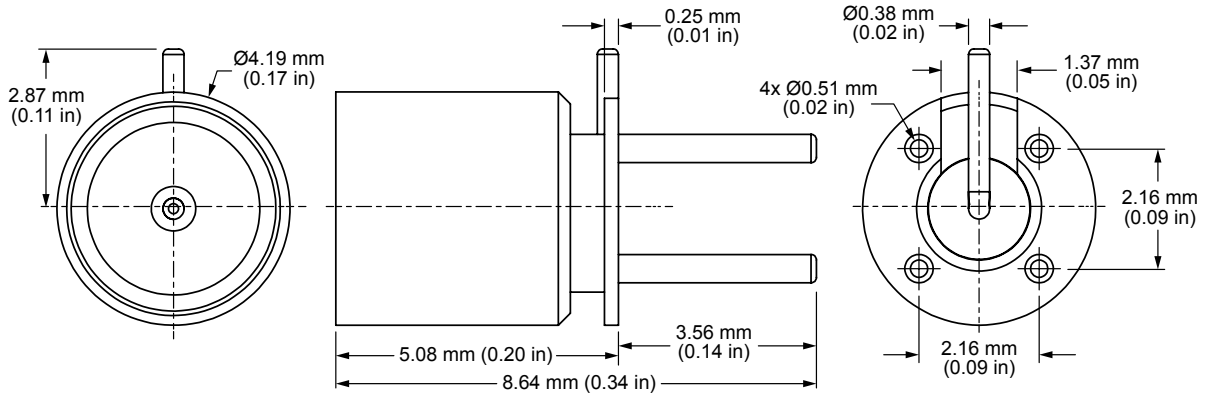

Figure 1. Product Dimensions for the CONSMPO01-2-G Connector Table

## 2. CONNECTOR COMPONENTS

Model	CONSMPO01-2-G	
Connector Part	Material	Finish
Connector Body	Beryllium Copper	Gold
Base	Beryllium Copper	Gold
Center Contact (male pin)	Beryllium Copper	Gold
Insulator	Torlon	-

## RECOMMENDED PCB FOOTPRINT

Figure 2 shows the connectors recommended PCB footprint and through-hole sizes.

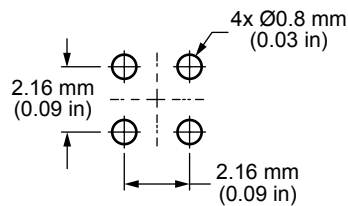

Figure 2. Recommended PCB Dimensions for the CONSMPO01-2-G

## CONNECTOR PERFORMANCE

Table 3 shows insertion loss and VSWR values for the CONSMP001-2-G connector at commonly used frequencies. Insertion loss is the loss of signal power (gain) resulting from the insertion of a device in a transmission line. VSWR describes how efficiently power is transmitted through the connector. A lower VSWR value indicates better performance at a given frequency.

**TABLE 3. INSERTION LOSS AND VSWR FOR THE CONSMP001-2-G CONNECTOR**

Band	Low-Band Cellular/ ISM/LPWA	GNSS, Midband Cellular, Wifi, WiFi 6E	Ku	Ka
Frequency Range	400 MHz to 960 MHz	1.1 GHz to 7.125 GHz	12 GHz to 18 GHz	26.5 GHz to 40 GHz
Insertion Loss (dB max.)	0.15	0.41	0.79	1.22
VSWR (max.)	1.0	1.1	1.3	1.4

**TABLE 4. MECHANICAL SPECIFICATIONS**

Model	CONSMP001-2-G
Mounting Type	PCB Through-Hole
Fastening Type	Snap-on Coupling
Interface in Accordance with	MIL-STD-348B
Connector Durability	100 cycles min.
Weight	0.35 g (0.01 oz)

**TABLE 5. ENVIRONMENTAL SPECIFICATIONS**

MIL-STD, Method, Test Condition	
Corrosion (Salt spray)	MIL-STD-202 Method 101 test condition B
Thermal Shock	MIL-STD-202 Method 107 test condition C
Vibration	MIL-STD-202 Method 204 test condition B
Mechanical Shock	MIL-STD-202 Method 213 test condition B
Moisture Resistance	MIL-STD-202 Method 106 test condition D
Temperature Range	-65 °C to +155 °C
Environmental Compliance	RoHS

## REFLOW SOLDER PROFILE

Figure 3 shows the time and temperature data for reflow soldering the connector to a PCB.

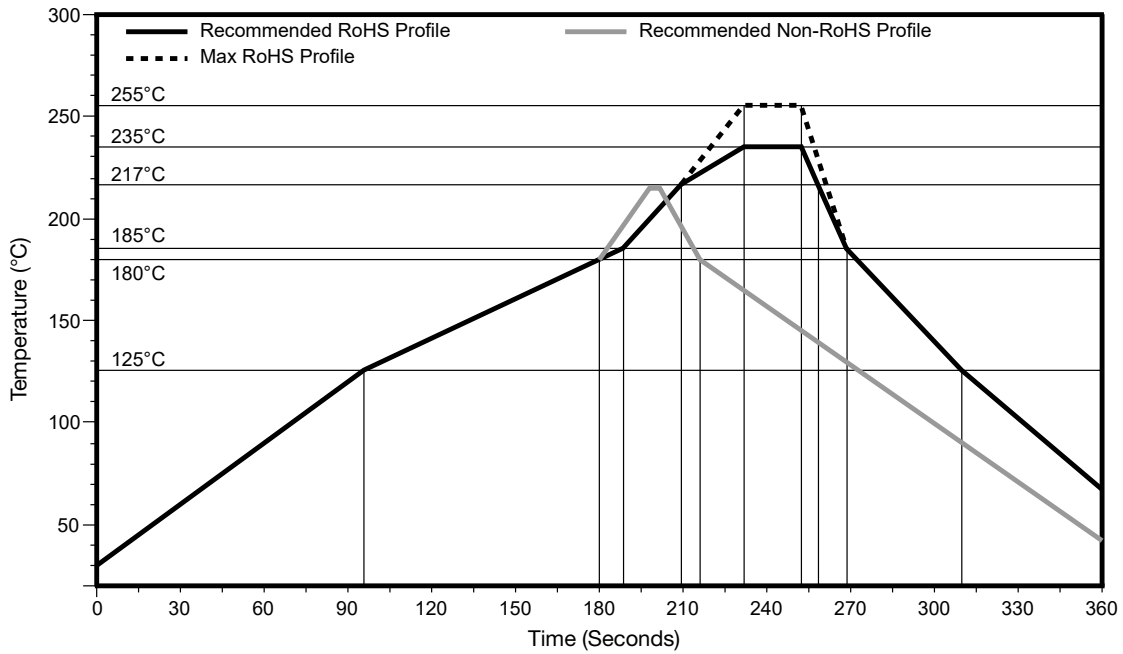

Figure 3. Recommended Reflow Solder Profile

## PACKAGING INFORMATION

The CONSMPO01-2-G connector is packaged in plastic trays of 150 pcs, 9000 Pcs per carton. Distribution channels may offer alternative packaging options.