CP2108 EVALUATION KIT USER'S GUIDE

1. Kit Contents

The CP2108 Evaluation Kit contains the following items:

- CP2108 evaluation board
- Four RS232 serial cables
- USB cable
- Quick Start Guide

2. Relevant Documentation

Application notes are available on the Interface application notes page for all fixed-function devices:

www.silabs.com/interface-appnotes.

- AN721: USBXpress™ Device Configuration and Programming Guide — Customize the VID, PID, serial number, and other parameters stored in the CP2108 EEPROM.
- AN197: Serial Communications Guide for CP210x — Programming guide for using the Virtual COM Port (VCP) drivers.
- AN169: USBXpress® Programmer's Guide — Programming guide for using the USBXpress drivers.
- AN220: USB Driver Customization — VCP or USBXpress driver customization tool.
- AN223: Runtime GPIO Control for CP210x — Programming guide and DLL for runtime control of the CP2108 GPIO pins.
- AN571: CP210x Virtual COM Port Interface — USB interface details for CP210x devices.

3. Software Setup

The software packages and documentation for the CP2108 kit are available on the device page (<https://www.silabs.com/interface/usb-bridges/classic/device.cp2108>) and include the following:

- CP210x Drivers (Software & Tools Tab)
- USBXpress Host SDK (Software & Tools Tab)
- Documentation: (Tech Docs Tab)
 - CP2108 data sheet
 - CP2108 Evaluation Kit User's Guide (this document)

3.1. USBXpress Driver Development Kit

The Silicon Laboratories USBXpress® Development Kit provides a complete host software solution for interfacing to CP210x devices. No USB protocol or host device driver expertise is required. Instead, a simple, high-level Application Program Interface (API) for the host software is used to provide complete USB connectivity. The USBXpress Development Kit includes Windows device drivers, Windows device driver installer, and a host interface function library (host API) provided in the form of a Windows Dynamic Link Library (DLL). See application note, "AN169: USBXpress® Programmer's Guide", for detailed information on using the USBXpress drivers.

The USBXpress drivers are available here: <https://www.silabs.com/developers/direct-access-drivers>. Click the USBXpress Development Kit link in the Downloads section to download the USBXpress drivers. Run the installer and follow the steps to install the software to the desired location. The default installation directory is:

C:\Silicon Labs\MCU\USBXpress_SDK.

Further installation instructions for the WinCE drivers are available in the ReadMe.txt file contained inside the driver package.

4. CP2108 Hardware Interface

Connect the CP2108 evaluation board to a PC as shown in Figure 1.

1. Connect one end of the USB cable to a USB Port on the PC.
2. Connect the other end of the USB cable to the USB connector on the CP2108 evaluation board.
3. Connect one end of the RS232 serial cable to one of the DB9 connectors on the CP2108 evaluation board.
4. Connect the other end of the RS232 serial cable to the target serial device.
5. To connect to additional serial devices, repeat Steps 3 and 4 using another RS232 serial cable and one of the unused DB9 connectors on the CP2108 evaluation board.

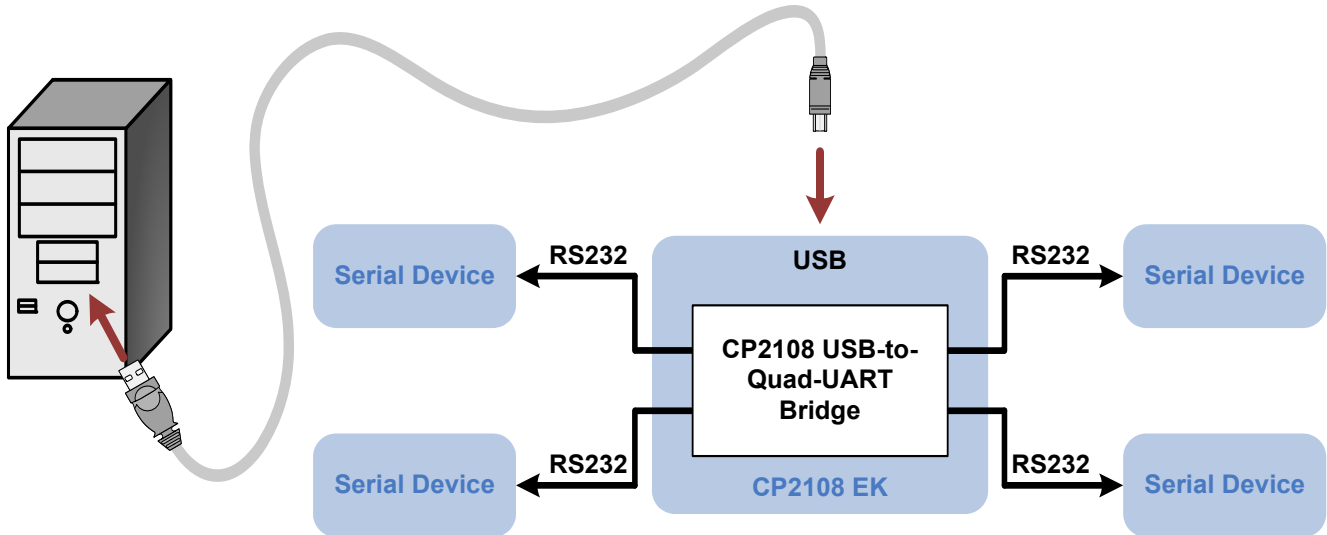

Figure 1. Hardware Setup

5. CP2108 Software Interface

If the Virtual COM Port drivers are used, the CP2108 will appear as four COM ports in the Device Manager, as shown in Figure 2. The CP2108 will always use the lowest available COM ports for operation. For instance, if COM ports 1 through 6 are in use by other peripherals and applications, the CP2108 will use COM 7, COM 8, COM 9 and COM 10.

The CP2108 functions identically to four COM ports from the reference point of both the host application and the serial devices, and it can support serial device control requests defined in the Microsoft Win32® Communications API. Examples for how to communicate with the device as two serial COM ports are included in application note, “AN197: Serial Communications for the CP210x” on the www.silabs.com/interface-appnotes page or in the USBXpress Host SDK.

If the USBXpress drivers are used, the CP2108 will appear as four USB USBXpress devices as shown in Figure 3. The USBXpress driver must be customized using application note, “AN220: USB Driver Customization”. Examples for how to communicate with the device using the USBXpress interface are included in application note, “AN169: USBXpress Programmer’s Guide”, on the www.silabs.com/interface-appnotes page.

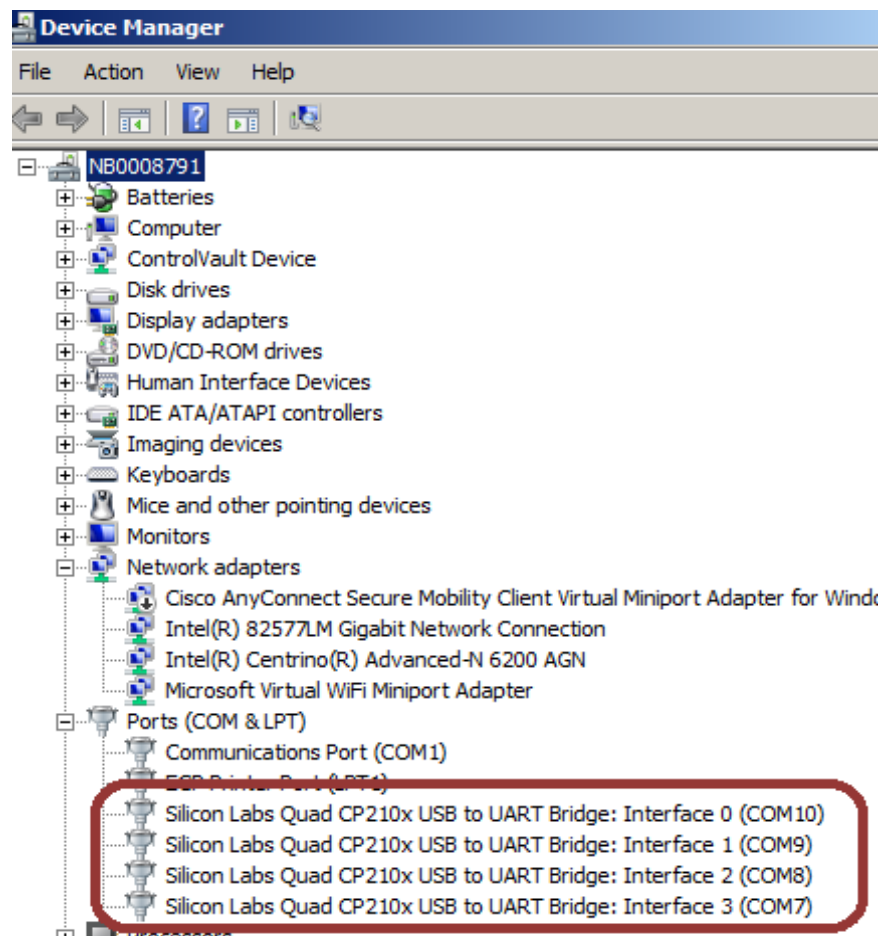

Figure 2. CP210x in Device Manager Using the VCP Driver

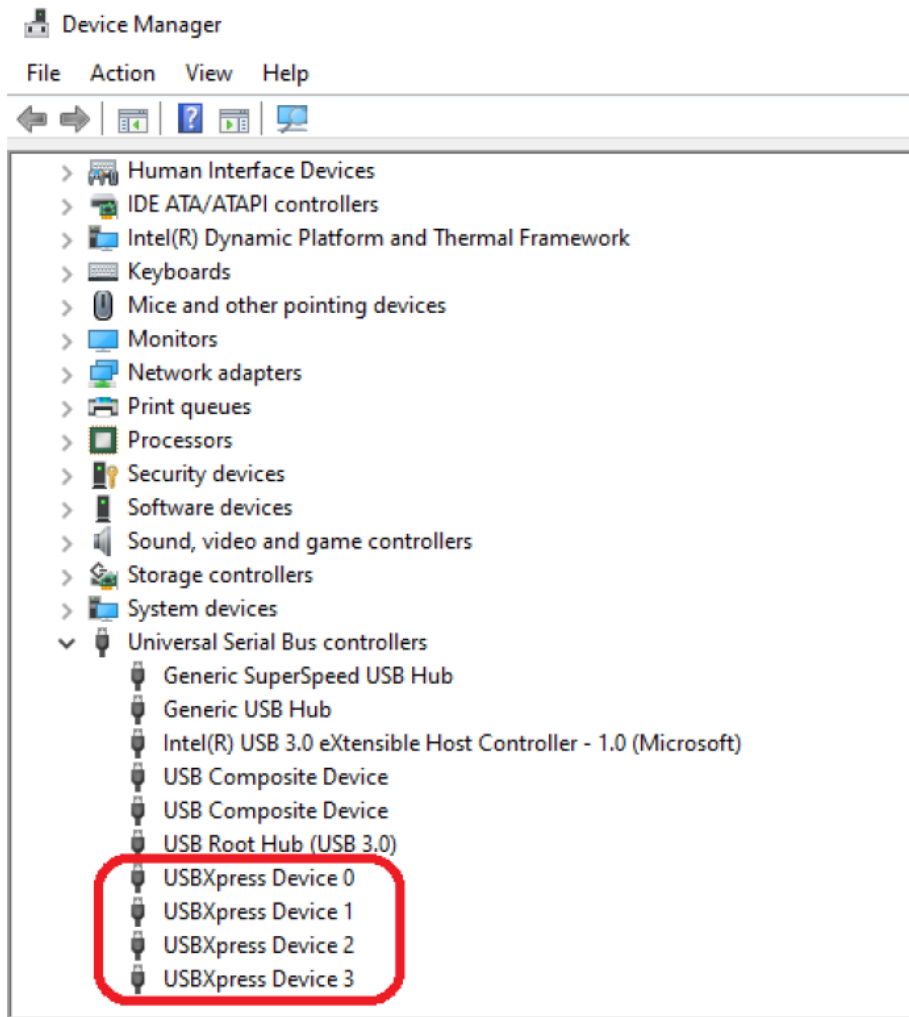

Figure 3. CP210x in Device Manager Using the USBXpress Driver

6. Target Board

The CP2108 Evaluation Kit includes an evaluation board with a CP2108 device pre-installed for evaluation and preliminary software development. Numerous input/output (I/O) connections are provided to facilitate prototyping using the evaluation board. Refer to Figure 4 for the locations of the various I/O connectors.

P0-3	DB9 connectors for the RS232 interface
P4	USB connector for USB interface
J0-3	UART signal access connector
J4	SUSPEND LED connector
DS8	Red SUSPEND indicator LED
J5	Board Power Selector (bus- or self-powered)
J6	GPIO0-7 LED Connector
J7	GPIO8-15 Rx/Tx Toggle Pins
J8	VBUS Pin Connection for current measurements
J9	+3V/VDD Connector Option
J10	VIO/VDD Connector Option
J11	NC Pins, GND
DS0-DS7	Green GPIO LEDs

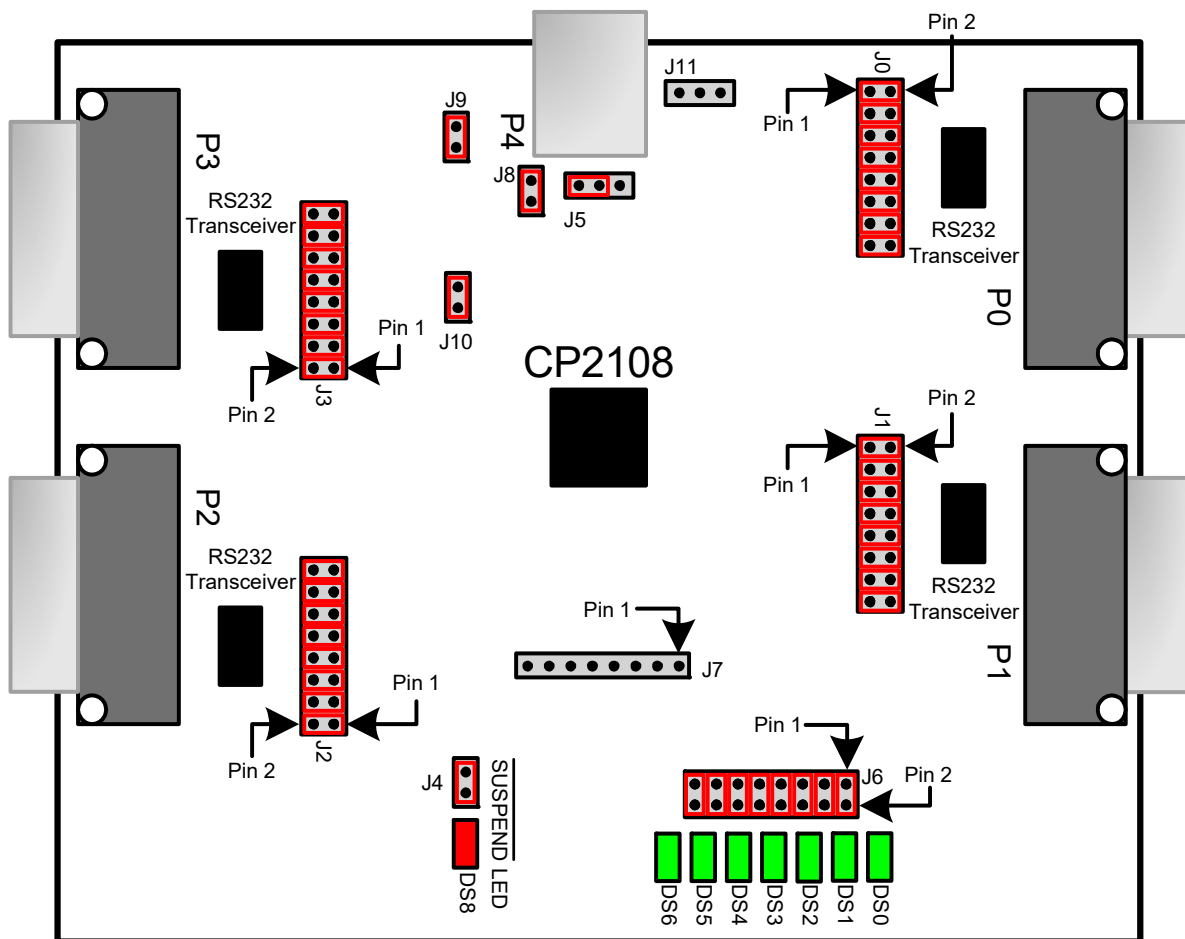

Figure 4. CP2108 Evaluation Board with Default Shorting Blocks Installed

CP2108-EK

6.1. DB9 Connector for RS232 Interface (P0-P3, J0-J3)

Four RS232 transceiver circuits and DB9 connectors (P0-3) are provided on the evaluation board to connect the CP2108 virtual serial ports to external serial devices. The headers J0-3 connect the CP2108 pins to the DB9 connectors and provide access to the RS232 signals. See Table 1 for the RS232 P0-3 pin descriptions and Table 2 for J0, J1, J2, J3 pin descriptions.

Table 1. RS232 Connector (P0-3) Pin Descriptions

Pin	Signal	CP2108 Direction	Description
1	DCD	Input	Data Carrier Detect
2	RXD	Input	Receive Data
3	TXD	Output	Transmit Data
4	DTR	Output	Data Terminal Ready
5	GND		Ground
6	DSR	Input	Data Set Ready
7	RTS	Output	Request to Send
8	CTS	Input	Clear to Send
9	RI	Input	Ring Indicator

Table 2. RS232 Header (J0-3) Pin Descriptions

Pins	Signal	CP2108 Direction	Description
1-2	TXD	Output	Transmit Data
3-4	RXD	Input	Receive Data
5-6	DTR	Output	Data Terminal Ready
7-8	RI	Input	Ring Indicator
9-10	DCD	Input	Data Carrier Detect
11-12	DSR	Input	Data Set Ready
13-14	CTS	Input	Clear to Send
15-16	RTS	Output	Request to Send

6.2. Board Power Selector (J5)

This header (J5) provides bus- or self-powered options for the CP2108 device.

- Pins 1-2 connect USB connector VBUS (P4) to the VREGIN pin on the CP2108 and puts the device in bus powered mode. The voltage regulator output appears on the VDD pin (pin 3).
- Pins 2-3 connect the CP2108 VREGIN to the CP2108 VDD pin and puts the device in self-powered mode. This bypasses the voltage regulator. A voltage of 1.8 to 3.6 V power must be supplied to the VDD pin.

6.3. Power Connectors (J9, J10)

The J9 and J10 headers are included on the evaluation board to provide several power options.

- J9 connects the main +3 V net to the CP2108 VDD pin. The VDD pin is the output of the on-chip regulator. The main +3 V net powers the other components (green LEDs and RS-232 transceivers) on the board. It can be disconnected using J9 for current measurement purposes.
- J10 connects the CP2108 VIO input to the CP2108 VDD pin. Remove the shorting block to power VIO from an external source.

6.4. VBUS Connector (J8)

The VBUS connector J8 connects the VBUS pin on the USB connector (P4) to the CP2108 VBUS pin. If the jumper is removed and a multimeter is inserted, the power consumption can be measured.

6.5. GPIO.0-7 LED Header (J6)

Place shorting blocks on J6 to connect the GPIO.0–7 pins to the eight green LEDs (DS0-DS7). These LEDs can be used to indicate active communications through the CP2108. Table 3 shows the LED corresponding to each header position. When using the CP2108 in modem mode, the shorting blocks on J6 should be removed.

Table 3. J6 LED Locations

LED	J6 Pins
DS0	1-2
DS1	3-4
DS2	5-6
DS3	7-8
DS4	9-10
DS5	11-12
DS6	13-14
DS7	15-16

6.6. GPIO.8-15 Header (J7)

The J7 header allows access to the GPIO.8-15 pins on the CP2108. These GPIO pins may be connected to the LEDs using J6 or used for alternate functions described in the CP2108 data sheet.

6.7. Universal Serial Bus (USB) Interface (P4)

A Universal Serial Bus (USB) connector (P4) is provided to facilitate connections to the USB interface on the CP2108. See Table 4 for the USB pin definitions.

Table 4. USB Connector Pin Descriptions

Pin #	Description
1	VBUS
2	D-
3	D+
4	GND (Ground)

6.8. SUSPEND LED Header (J4)

The J4 header enables the DS8 LED on the $\overline{\text{SUSPEND}}$ output pin on the CP2108.

7. Schematic

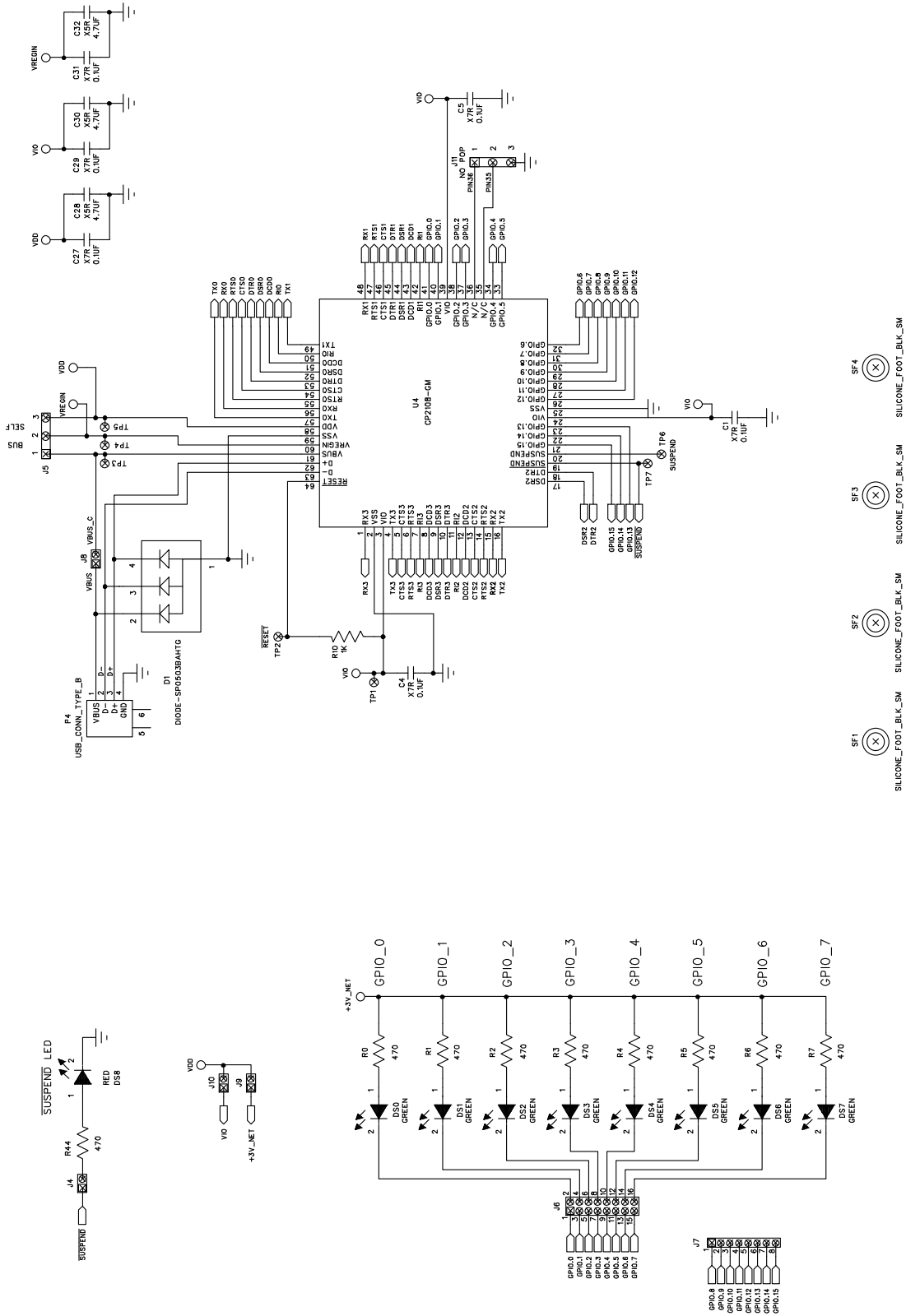

Figure 5. CP2108 Evaluation Kit Board Schematic (1 of 2)

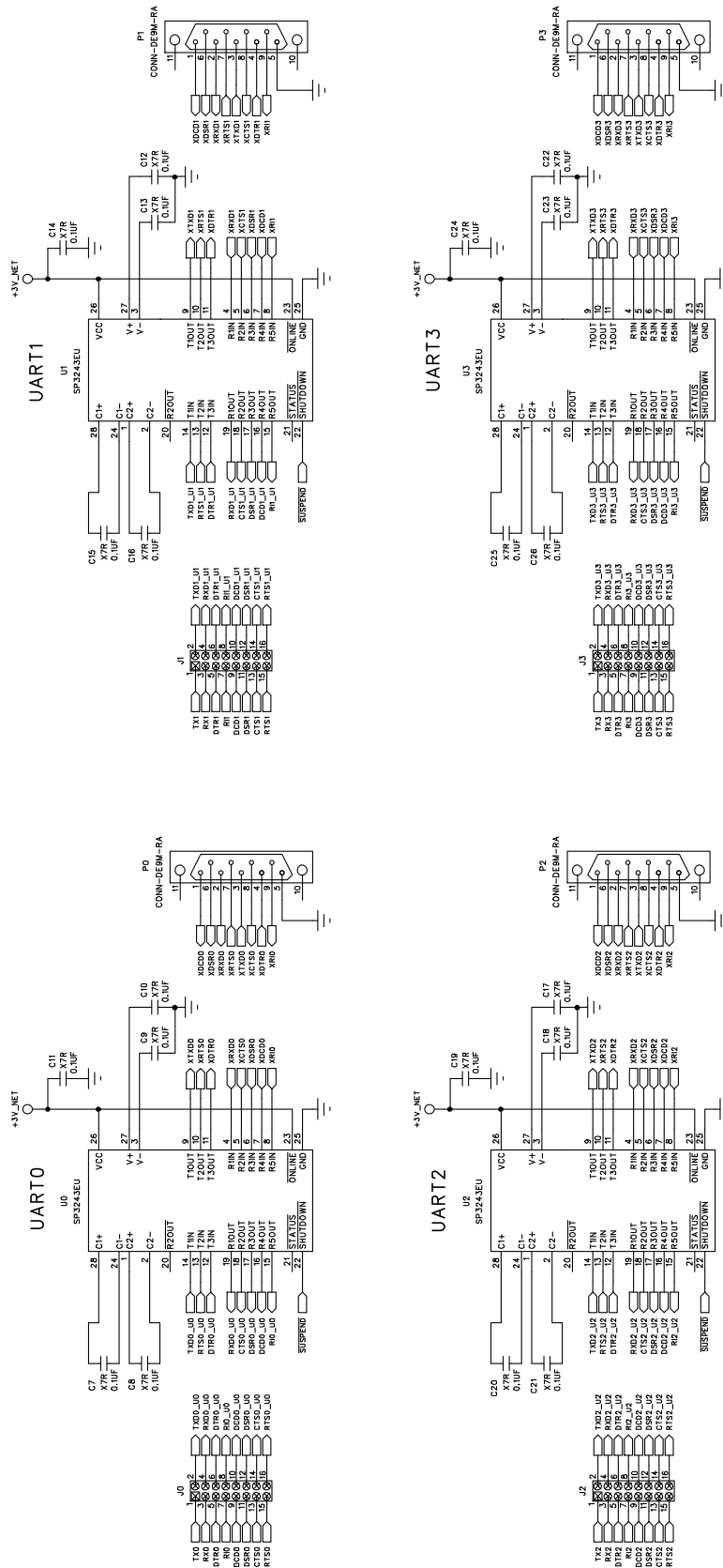

Figure 6. CP2108 Evaluation Kit Board Schematic (2 of 2)