

## CPDV3V3A-HF

**RoHS Device**  
**Halogen Free**

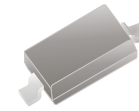

### Features

- Transient protection for high-speed data lines  
IEC61000-4-2 (ESD)  $\pm 15\text{kV}$  (air),  $\pm 8\text{kV}$  (contact)  
IEC61000-4-4 (EFT) 40A (5/50ns)  
Cable discharge event (CDE)
- Ultra-small package.
- Protects one data, control line.
- Low capacitance: 0.25pF (typical).
- Low leakage current.
- Low clamping voltage.

### Mechanical data

- Case: SOD-323 package.
- Flammability rating: UL 94V-0.
- High temperature soldering guaranteed:  
260°C/10s

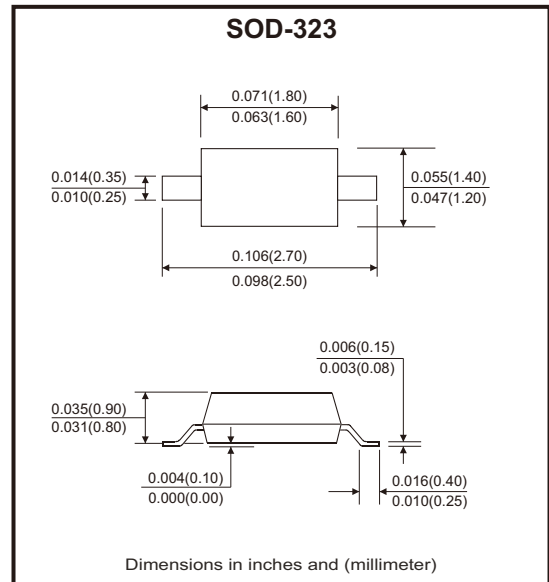

### Circuit diagram



### Maximum Rating (at Ta=25°C unless otherwise noted)

Parameter	Symbol	Value	Unit
ESD per IEC 61000-4-2 (air)	V <sub>ESD</sub>	$\pm 20$	kV
ESD per IEC 61000-4-2 (contact)		$\pm 20$	
Peak pulse power (8/20 $\mu$ s)	P <sub>PP</sub>	100	W
Operating temperature range	T <sub>OPT</sub>	-55 to +125	°C
Storage temperature range	T <sub>STG</sub>	-55 to +150	°C

### Electrical Characteristics (at Ta=25°C unless otherwise noted)

Parameter	Conditions	Symbol	Min	Typ	Max	Unit
Reverse working voltage		V <sub>RWM</sub>			3.3	V
Reverse breakdown voltage	I <sub>T</sub> = 1mA	V <sub>BR</sub>	4.2			V
Reverse leakage current	V <sub>RWM</sub> = 3.3V	I <sub>R</sub>			100	nA
Clamping voltage	I <sub>PP</sub> = 1A, T <sub>P</sub> = 8/20 $\mu$ s	V <sub>C</sub>			12	V
	I <sub>PP</sub> = 4A, T <sub>P</sub> = 8/20 $\mu$ s				25	
Junction capacitance	V <sub>R</sub> = 0V, f = 1MHz	C <sub>J</sub>		0.25	0.4	pF

Company reserves the right to improve product design, functions and reliability without notice.

REV:A

## Rating and Characteristic Curves (CPDV3V3A-HF)

Fig.1 - Power Derating Curve

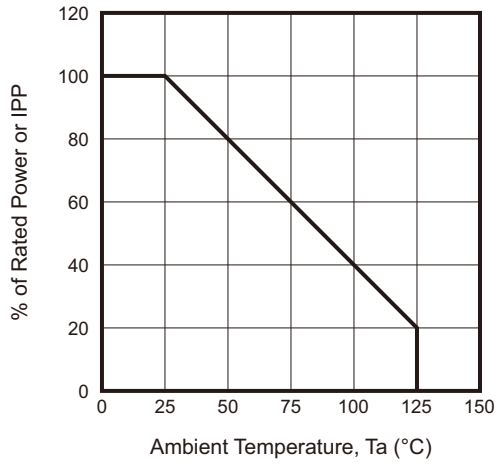

Fig.2 - Clamping Voltage vs Peak Pulse Current

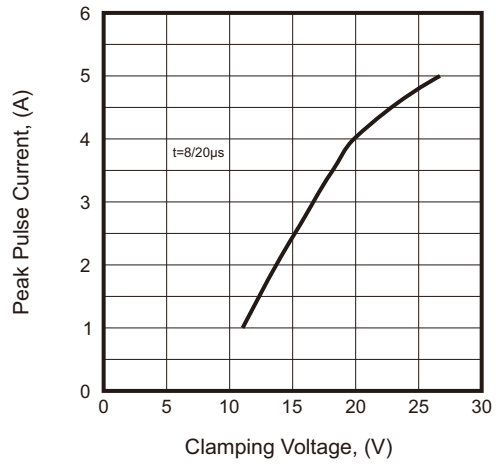

Fig.3 - Voltage Sweeping

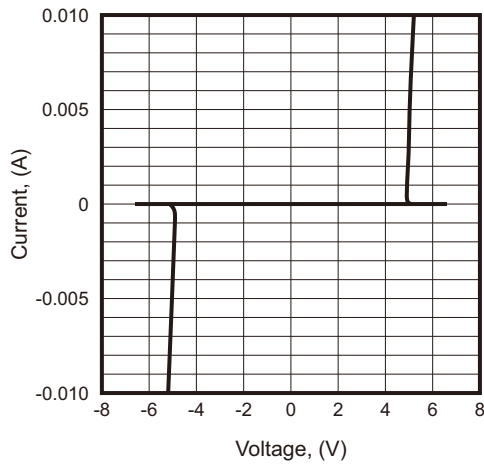

Fig.4 - Voltage vs Capacitance

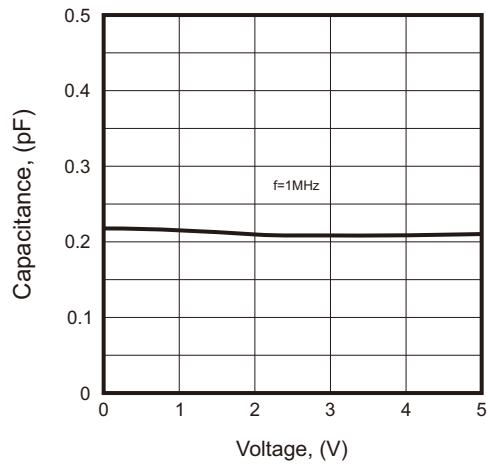

Fig.5 - ESD Clamping (+8kV Contact per IEC 61000-4-2)

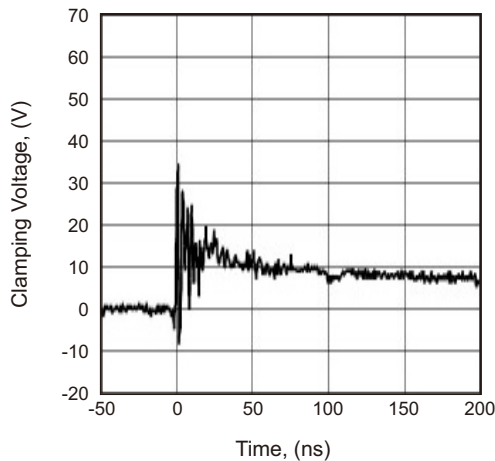
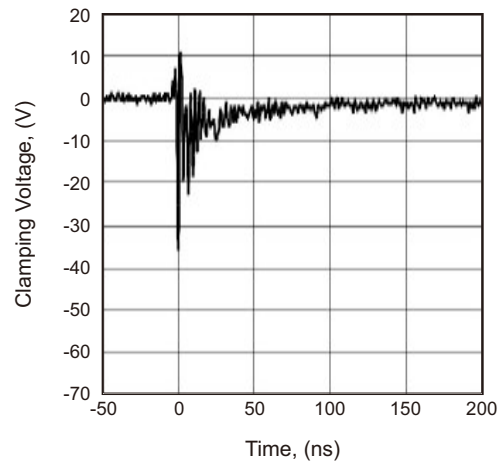
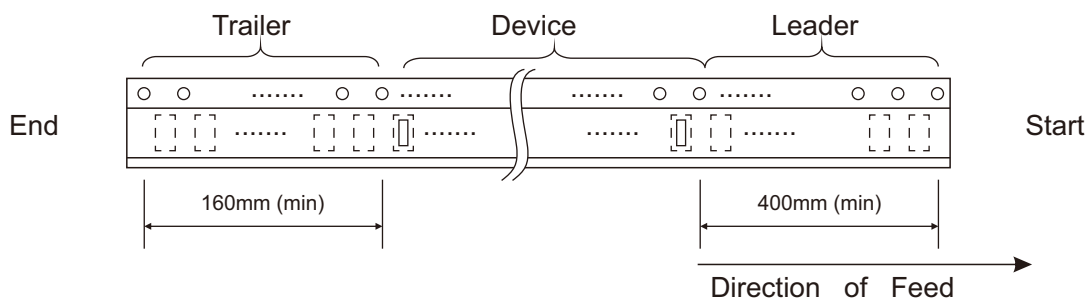
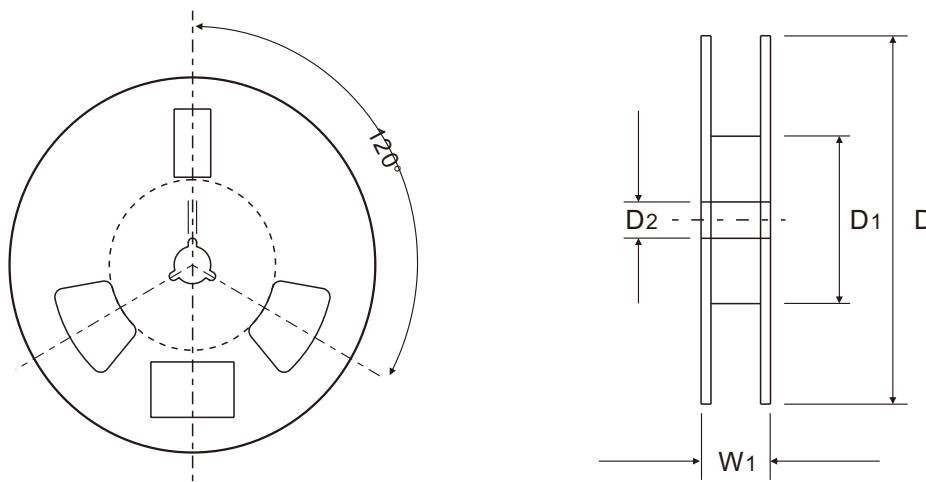
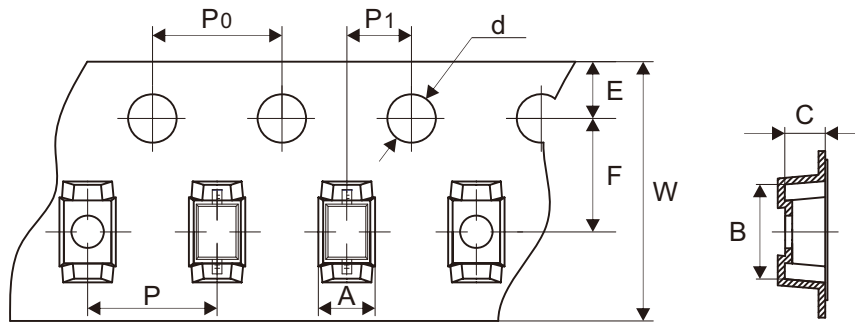

Fig.6 - ESD Clamping (-8kV Contact per IEC 61000-4-2)



## Reel Taping Specification



SOD-323	SYMBOL	A	B	C	d	D	D1	D2
	(mm)	1.46 ± 0.05	2.90 ± 0.05	1.25 ± 0.05	1.50 ± 0.10	178.00 ± 2.00	54.40 ± 1.00	13.00 ± 1.00
	(inch)	0.057 ± 0.002	0.114 ± 0.002	0.049 ± 0.002	0.059 ± 0.004	7.008 ± 0.079	2.142 ± 0.039	0.512 ± 0.039

SOD-323	SYMBOL	E	F	P	P0	P1	W	W1
	(mm)	1.75 ± 0.10	3.50 ± 0.10	4.00 ± 0.10	4.00 ± 0.10	2.00 ± 0.10	8.00 + 0.30 - 0.10	12.30 ± 1.00
	(inch)	0.069 ± 0.004	0.138 ± 0.004	0.157 ± 0.004	0.157 ± 0.004	0.079 ± 0.004	0.315 + 0.012 - 0.004	0.484 ± 0.039

Company reserves the right to improve product design, functions and reliability without notice. REV:A