

Art.-Number: 701067

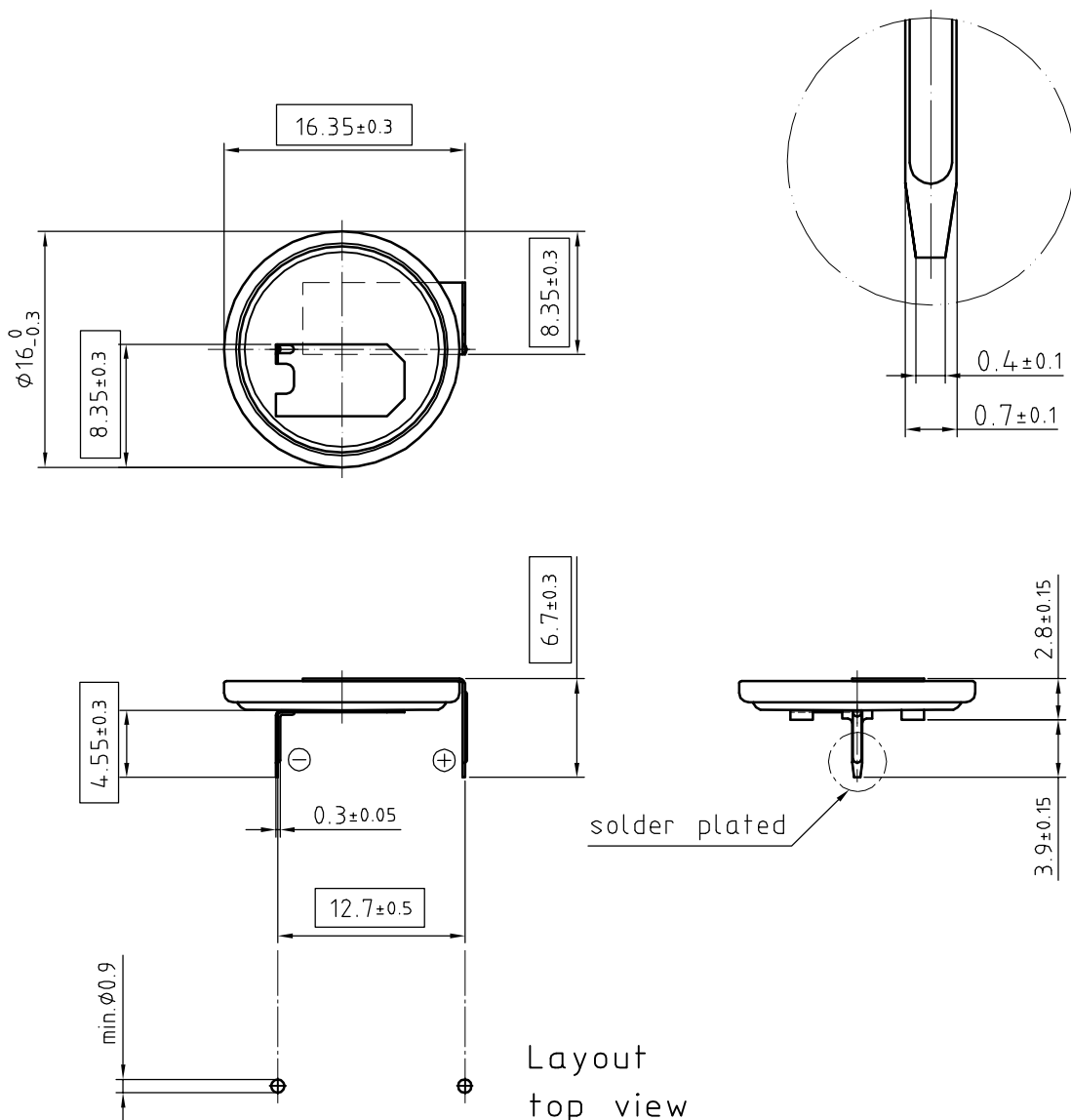

Layout
top view

All dimensions in mm.

Tab material: Stainless steel

Direction of tab corrugation could be to the inner side, or outer side

All framed values will be used for dimension checking !

The Products of Renata SA are neither designed nor authorized for use in certain areas of application of environment.
For further details we refer to our webpage www.renata.com/downloads/restriction_of_use

Rev.	①	23.08.19	PWu	Rev.	○				Customer's Approval		
Rev.	○			Rev.	○				Date		
Rev.	○			Rev.	○				Signature		
Title:								Scale	Drawn	22.12.04	SRI
CR1620FH-LF								2:1	Checked		
								Approved			
				CH-4452 Itingen Switzerland				3.8704.4-1			

Samples can deviate in the execution from the serie.

Dimensions and tolerances can be specified only after the testing of the devices for the mass production definitely