

8-MOSFETS for RASPBERRY PI

USER'S GUIDE VERSION 3.0

SequentMicrosystems.com

GENERAL DESCRIPTION..... 2

FEATURES..... 3

WHAT IS IN YOUR KIT..... 4

QUICK START-UP GUIDE..... 5

BOARD LAYOUT..... 6

STACK LEVEL JUMPERS..... 7

RS-485 COMMUNICATION..... 7

POWER REQUIREMENTS..... 8

MECHANICAL SPECIFICATIONS..... 9

SOFTWARE SETUP..... 10

GENERAL DESCRIPTION

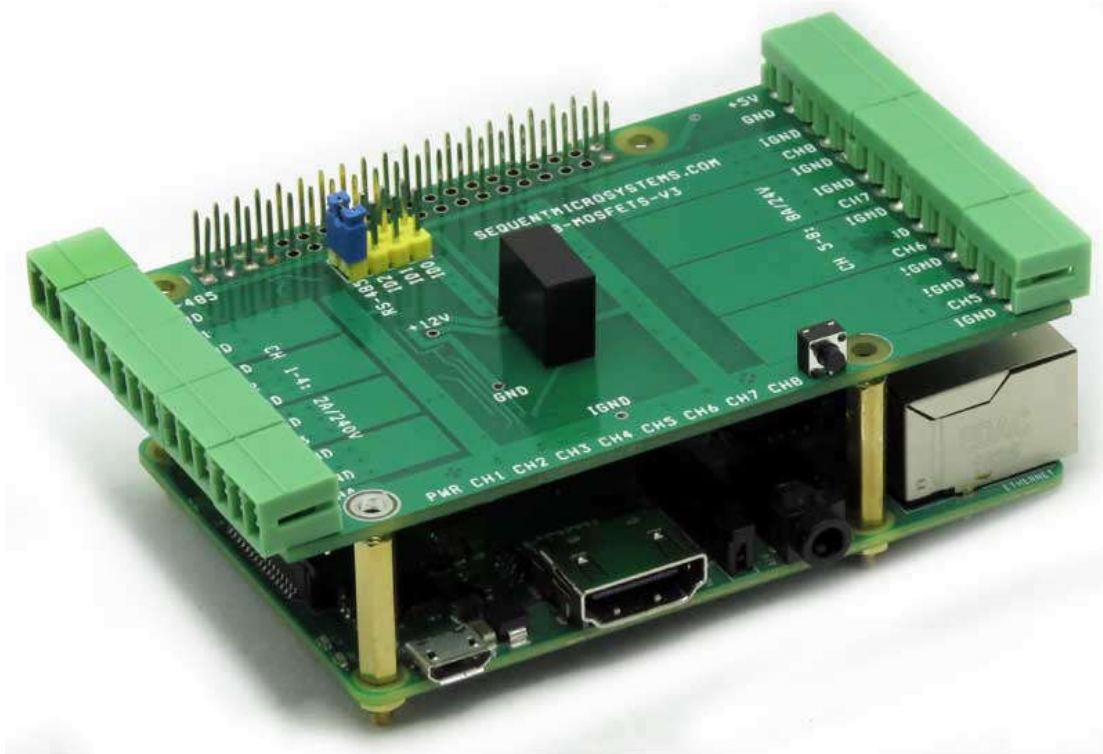

The 8-MOSFETS card is a stackable expansion card for Raspberry Pi. The card is compatible with all Raspberry Pi versions from Zero to 4. It offers a compact and inexpensive solution for adding up to 64 MOSFETs to your Raspberry Pi project.

Pluggable connectors make the 8-MOSFETS card easy to use when multiple cards are stacked up. Four MOSFETS are optimized for current and can switch up to 10A and 48VDC. The other four MOSFETS are optimized for voltage and can switch up to 300VDC and 4A. Status LEDs show when MOSFETs are on or off.

Each MOSFET has a corresponding LED installed on the long side of the card which turns on when the MOSFET is energized. A LED also shows when power is applied to the board. A pushbutton permits the user to issue a command to Raspberry Pi or to shut it down (a script is required for the desired application).

The 8-MOSFET card has also an RS485 driver which can communicate with other industrial equipment using the MODBUS protocol.

Mechanically, the 8-MOSFET card adheres to the Sequent Microsystems Modular Industrial format. It can be installed in the free 3D printable stackable enclosure. All the cards in this format have the same mechanical specifications.

FEATURES

- Eight MOSFETs with Status LEDs
- Pluggable Connectors 26-16 AWG wires
- 4 High Current (HC) Loads @ 10A/24VDC
- 4 High Voltage (HV) Loads @ 2A/240VDC
- RS485 Port with TVS protection
- Reverse polarity power supply protection
- General purpose pushbutton
- All mounting hardware included: brass stand-offs, screws and nuts
- Software self-test
- Command Line, Node-RED and Python Drivers

Up to eight 8-MOSFETS cards can be stacked on top of one Raspberry Pi. The 8-MOSFETS cards share a serial I2C bus using only two of the Raspberry Pi's GPIO pins to manage all eight cards. This feature leaves the remaining 24 GPIOs available for the user.

WHAT IS IN YOUR KIT

1. 8-MOSFETS add-on card for Raspberry Pi

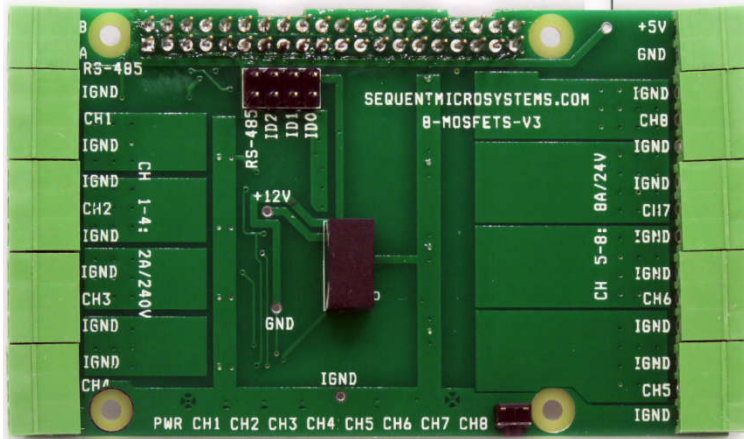

2. Mounting hardware



- a. Four M2.5x18mm male-female brass standoffs
- b. Four M2.5x5mm brass screws
- c. Four M2.5 brass nuts

3. Two jumpers.



You do not need the jumpers when using only one card. See STACK LEVEL JUMPERS section if you plan to use multiple cards.

4. All the required female mating connectors.

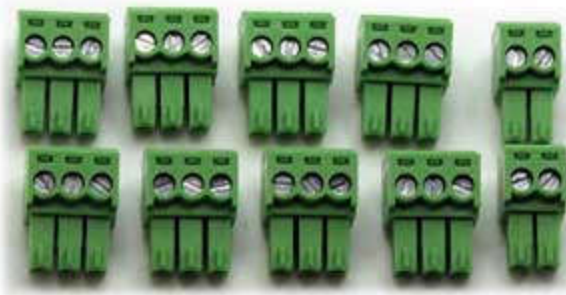

QUICK START-UP GUIDE

1. Plug your 8-MOSFETS card on top of your Raspberry Pi and power up the system using only one 5V/3A power supply.
2. Enable I2C communication on Raspberry Pi using raspi-config.
3. Install the 8-MOSFETS software from github.com:
 - a. `~$ git clone https://github.com/SequentMicrosystems/8mosfet-rpi.git`
 - b. `~$ cd /home/pi/8mosfet-rpi`
 - c. `~/8mosfet-rpi$ sudo make install`
4. `~/8mosfet-rpi$ 8mosfet`

The program will respond with a list of available commands.
5. Connect your load between pin 2 of any of the load connectors and the positive side of your external power supply.
6. Connect the negative side of your external power supply to pin 1 of the output connectors.
7. Turn on and off the load using the corresponding command.

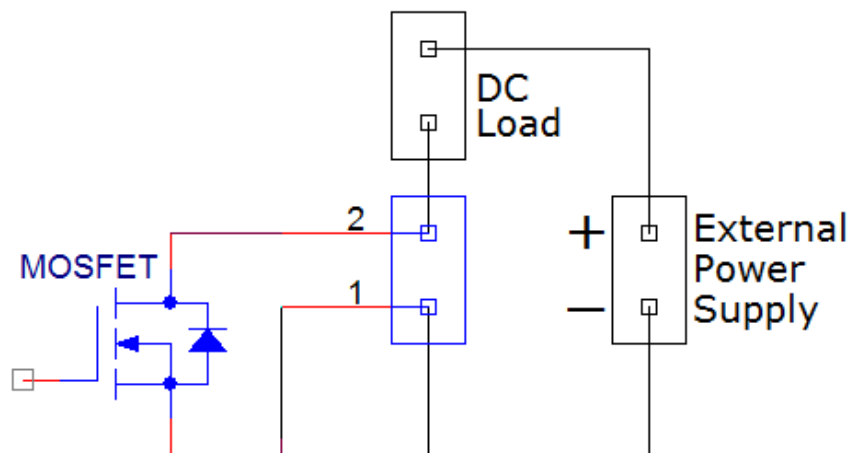

BOARD LAYOUT

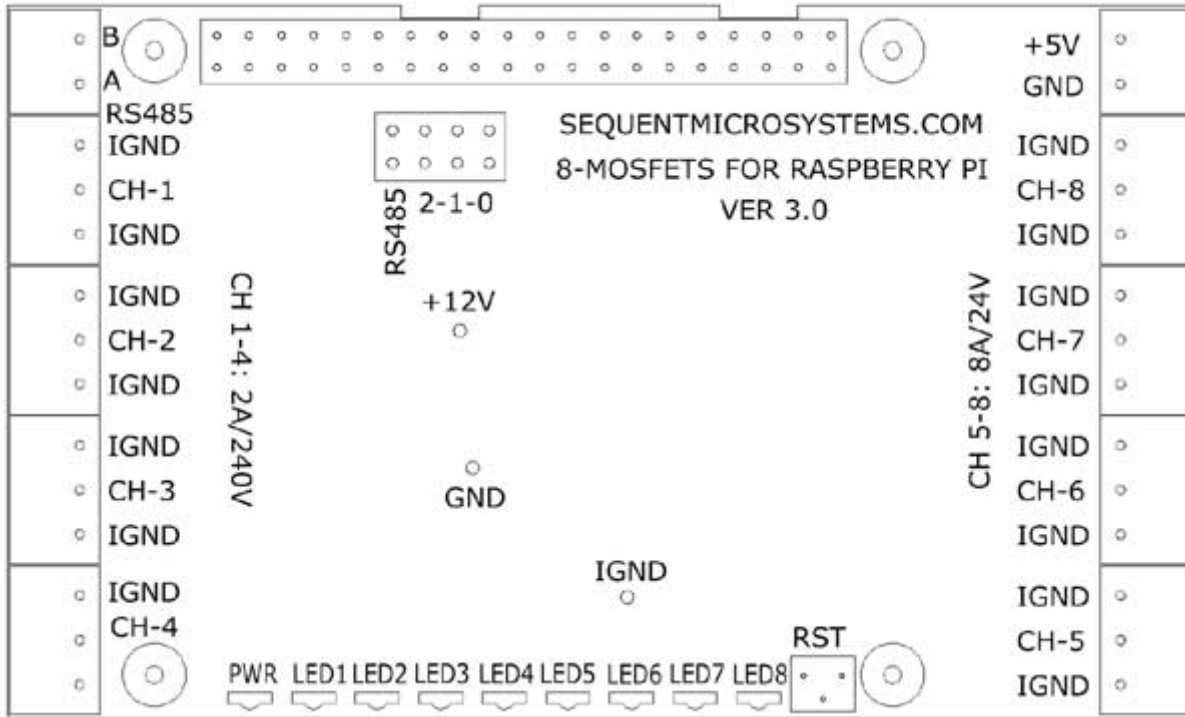

Your 8-MOSFETS card comes with appropriate mounting hardware. Up to eight 8-MOSFETS cards can be stacked on top of one Raspberry Pi. Eight LEDs indicate the status of their respective MOSFET. An LED is lit when the corresponding MOSFET is energized. The General Purpose Pushbutton GPB is connected to pin 37 of the Raspberry Pi GPIO connector (GPIO26). In order to use the pushbutton you need to write a shell script to accomplish the desired function.

All MOSFETS have the open drain output and two ground signals brought out to pluggable connectors.

The three right-most positions of the jumper block are used for selecting the stack level (see next section). The left position is used for the RS485 port. The port is driven by the serial pin of Raspberry Pi. Install the jumper if you want to use the RS485 port. Remove the jumper if the serial port of Raspberry Pi is used for another purpose.

STACK LEVEL JUMPERS

Up to eight 8-MOSFETS cards may be stacked on your Raspberry Pi module. The card occupies the address space 0x38 - 0x3F. Each card is identified by jumpers you install to indicate the level in the stack. Cards can be installed on Raspberry Pi in any order. The 3 position jumper is selecting the stack level of the card, as follows:

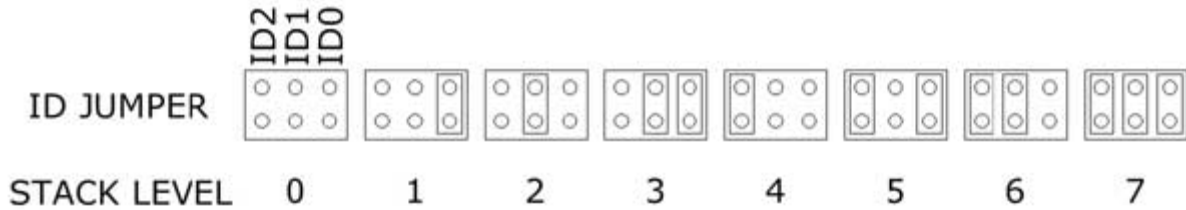

RS-485 COMMUNICATION

The 8-MOSFETS cards card contains a standard RS485 transceiver which can be accessed by the serial port of the Raspberry Pi. In order to enable communication, the jumper labeled RS485 on J2 connector needs to be installed.

POWER REQUIREMENTS

The 8-MOSFETS card requires +5V power, supplied either from the Raspberry Pi expansion bus, or from its own pluggable connector. The MOSFETS are triggered using an on-board 12V power supply galvanically isolated from the 5V power supply.

Raspberry Pi current consumption: 250 mA @ +5V (could be as high as 2A)

8-MOSFETS Card current consumption: 25 mA @ +5V

The power connector which powers the 8-MOSFETS card can handle up to 4A and is protected by a 3A resettable fuse. We recommend using a 5V regulated power supply rated at 3A or higher. The 8-MOSFET card can be stacked up to eight levels. A multi-stack configuration can be powered from any of the cards.

MECHANICAL SPECIFICATIONS

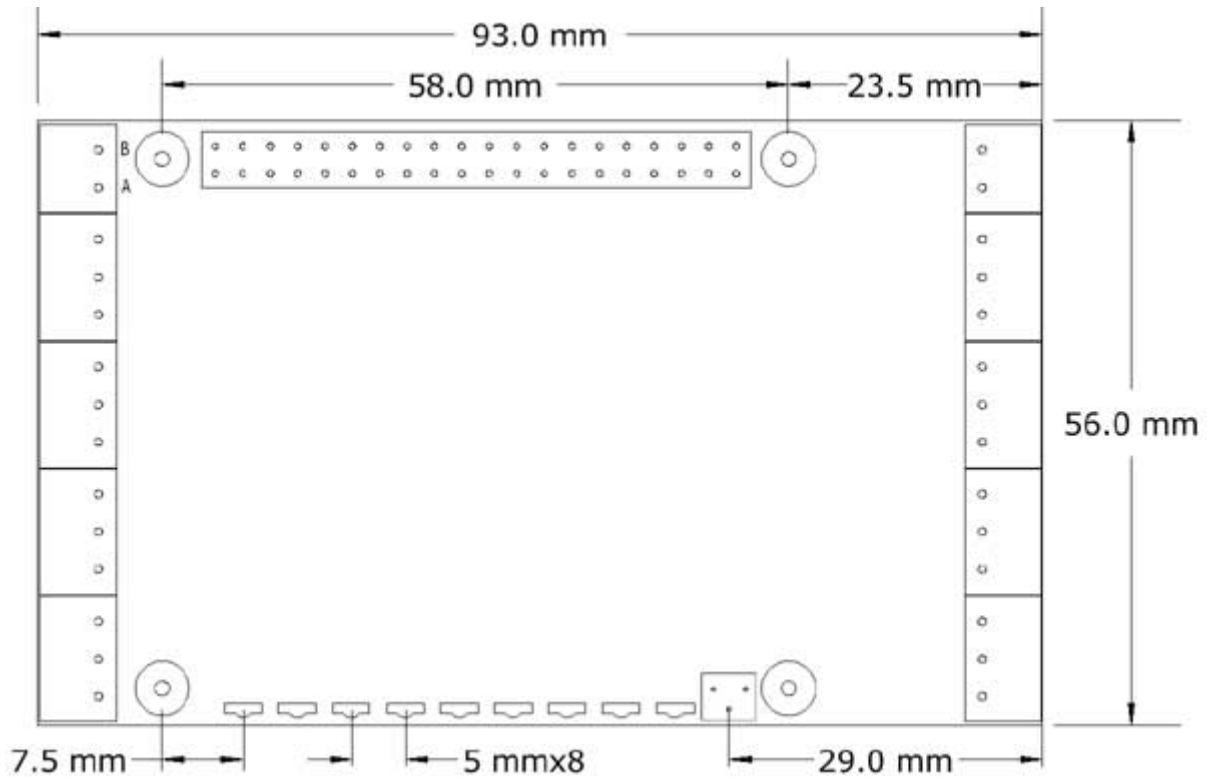

The card is compatible with any card manufactured by Sequent Microsystems and can be mounted in any order. You may also intermix cards from other vendors, assuming they do not use the same I2C address. It can be installed in the 3d-printable modular enclosure available for download from our website.