

**SERIES:** CSXX150B | **DESCRIPTION:** CURRENT SENSOR**FEATURES**

- open loop
- bipolar
- detects current direction
- single channel



MODEL	rated current (If)	linearity range <sup>1</sup> (Im)
	(A <sub>RMS</sub> )	(A <sub>PEAK</sub> )
CS03150B	±3	±9
CS05150B	±5	±15
CS10150B	±10	±30
CS15150B	±15	±45
CS20150B	±20	±60

Notes: 1. Im is the maximum peak current for which the output voltage specifications are guaranteed, however the If RMS rating must not be exceeded.  
 2. All specifications measured at 25°C, RI=10 kΩ, unless otherwise noted.  
 3. It is recommended to add a 1 μF capacitor connected between the common terminal 4 and the +12 V and -12 V terminals, 1 and 2, to avoid noise problems.

**SPECIFICATIONS**

parameter	conditions/description	min	typ	max	units
supply voltage (Vcc)		±14.25	±15.0	±15.75	V
max current consumption (Ic)				25	mA
output voltage (Vo)	at +If	±3.96	±4.00	±4.04	V
zero current offset voltage (Vr)	after demagnetization	-0.03	0	+0.03	V
output voltage linearity <sup>4</sup> (ΔKo)				±0.5	%
response (tr)	at di/dt = If/μs		3		μs
output voltage temperature characteristics				±0.1	%/°C
zero current offset voltage characteristics				±1.5	mV/°C
hysteresis (Vh)	at +If to zero current			15	mV
primary over current	for maximum 50 ms, no damage			10*If	A
withstand voltage	between coil and each terminal for 1 minute		2,000		Vac
insulation resistance	between coil and each terminal at 500 Vdc		500		MΩ
operating temperature		-10		75	°C
storage temperature		-30		90	°C
safety approvals	UL 508				
flammability rating	UL94V-0				
RoHS	yes				

Notes: 4. Deducing the value of hysteresis and offset voltage, calculated by (V/Vo)/(IfxI-1)x100%.

## SOLDERABILITY

parameter	conditions/description	min	typ	max	units
hand soldering	for maximum 3 seconds		280		°C

## MECHANICAL

parameter	conditions/description	min	typ	max	units
dimensions	15 x 15 x 20				mm
case material	PBT				
terminals	phosphor bronze with tin plating				
weight			8		g

## MECHANICAL DRAWING

units: mm  
tolerance: ±0.5 mm

PIN CONNECTIONS	
PIN	FUNCTION
1	+15 V
2	-15 V
3	Output (V)
4	0 V
5	+Input (A)
6	-Input (A)

MODEL NO.	ØA (mm)	ØB (mm)
CS03150B	0.6	1.2
CS05150B	0.9	1.5
CS10150B	1.1	1.7
CS15150B	1.4	2.0
CS20150B	1.7	2.3

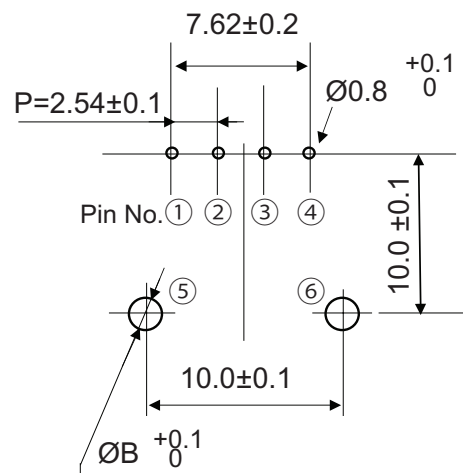
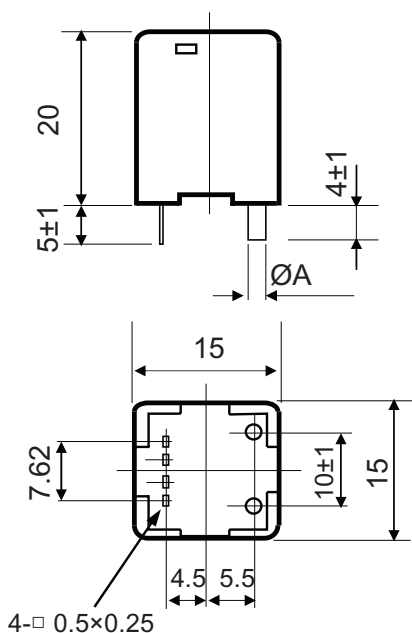

Recommended PCB Layout  
Top View

## DERATING CURVE



## PERFORMANCE CURVES

Output Voltage vs. Input Current

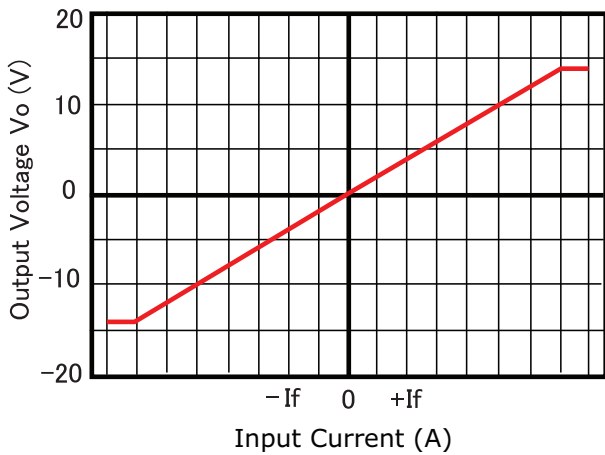

Input Current Frequency vs. Output Attenuation

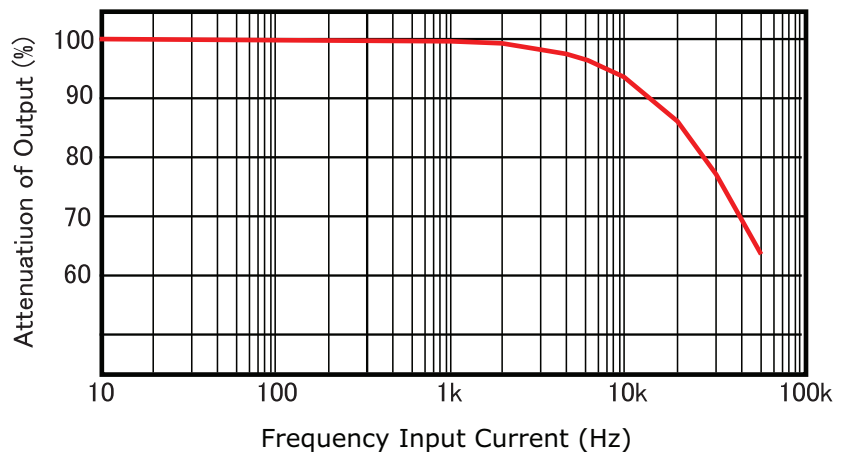

Output Voltage vs. Ambient Temperature  
(at +If)

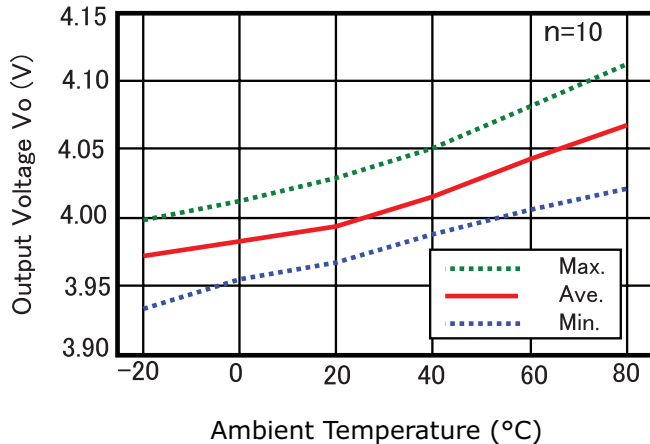

Offset Voltage vs. Ambient Temperature  
(at Zero Current)

