



# CTD452 User Guide

## Referenced Devices

CT452 – XtremeSense® TMR IC  
CTD452 – Evaluation Board

## Introduction

This user guide describes the operation and use of the CTD452 demo board as an engineering tool for evaluating the CT452 IC performance in contactless current sensing applications.

The CT452 is a differential magnetic field sensor IC that detects a current induced magnetic flux and outputs a voltage proportional to the AC or DC current flow. The CT452 integrates two patented XtremeSense® TMR flux sense elements configured for common field rejection, high bandwidth, high current accuracy, and immune to external magnetic field noise. It achieves a total output error of less than  $\pm 0.7\%$  FS (typ) with a total lifetime drift of  $\pm 1.0\%$  FS (typ).

The CTD452 is a 4-layer (3 oz copper) PCB designed to test two types of contactless current sensing methods: with a PCB trace for  $<75 A_{PK}$  current or with a busbar for  $300 A_{NOMINAL}$  current. Both the PCB current carrying trace and the supplied copper busbar have three (3) slits for current steering and generating a differential magnetic field.

## Features

- Total Error:  $\pm 0.7\%$  FS (Typ.)
- Available Field Ranges:
  - +6 mT
  - $\pm 6$  mT
  - +12 mT
  - $\pm 12$  mT
  - +24 mT
  - $\pm 24$  mT
- Built-in Galvanic Isolation
- Low Noise Performance
- 1 MHz Operating Bandwidth
- $\sim 300$  ns Signal Response
- Immunity to Common Mode Fields

## General Description

The CTD452 demo board shown in Figure 1 features:

- 1x CT452 current sense IC
- 1x 4-layer 3oz copper PCB
- 1x 100 pF SMD capacitor (optional)
- 1x 1  $\mu$ F SMD capacitor
- 1x 5 pF SMD capacitor
- Six pin male header for biasing and measurements
- 2x Metal screw connectors
- 2 Sets of nylon screws and nuts
- 1x Custom slitted busbar

The CTD452 is enabled by applying a 5.0V bias between the  $V_{CC}$  and GND pins. The voltage corresponding to the detected flux is available on the Out pin. The  $V_{REF}$  pin provides a voltage that is half of  $V_{CC}$  while the FLTB pin provides an active low signal for an over-field or under-voltage condition. The FILT pin has a capacitor C3 to improve noise performance. Figure 2 shows the schematic and table for C3 value options. Please review the CT452 datasheet for more detailed electrical and performance specifications.

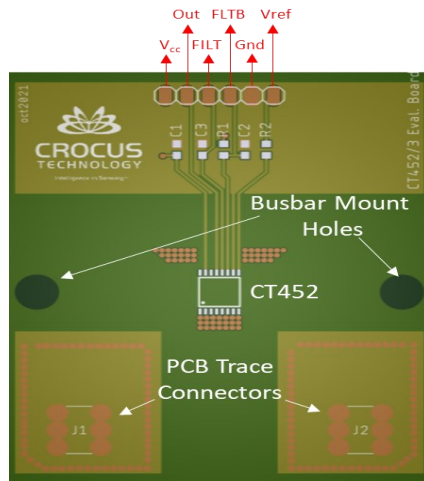

**FIGURE 1 CTD452 DEMO BOARD**

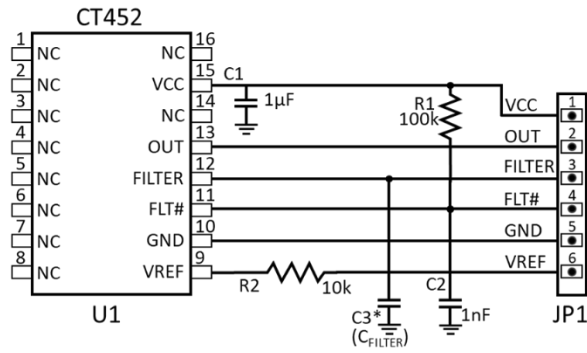

**Table 1. Capacitor C3 Options for FILTER pin**

Cut-off Frequency	*C <sub>FILTER</sub> (pF)	Capacitor Part Number
100 kHz	91	GRM0225C1C910JA02
250 kHz	33	GRM0225C1C330JA02
500 kHz	16	GRM0225C1C160JA03
1.0 MHz	5	GRM0225C1C5R0CA03

**FIGURE 2 CTD452 DEMO BOARD SCHEMATIC**

### PCB Current Sensing (Steady State Current < 75A<sub>pk</sub>)

In this configuration, the busbar is removed so current is measured by placing the CTD452 in-line between the supply voltage and the load as shown in Figure 3. For DC currents the supply voltage must be connected to the 'Current IN' terminal (Red) and the load is connected to the 'Current OUT' (Black) terminal resulting in a current flow through the PCB trace underneath the CT452 IC. The top layer of the EVB has the CT452 IC as well as the signal traces routed to

the 6-pin header. The remaining 3 layers of the PCB are used to carry the in-line current. The maximum current passed through the EVB is limited by the thermal capability of the PCB layers.

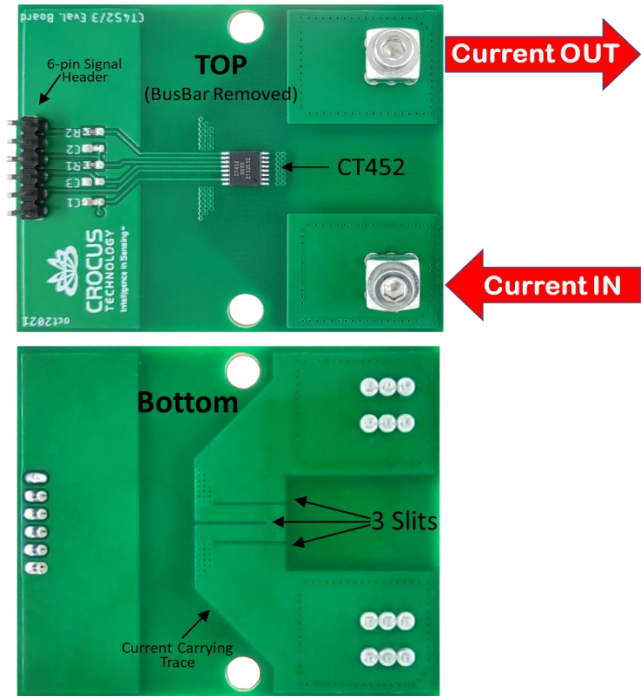

**FIGURE 3 CTD452 PCB CURRENT SENSING**

### Busbar Current Sensing (300 A<sub>NOMINAL</sub>)

As shown in Figure 4, the custom slitted busbar is placed over the CT452 for measuring currents in the range of 70~300A. It can carry a steady state current of 300A with a peak current of ~900A. When installing the busbar, make sure the slit orientation is opposite to the bottom PCB trace's slit orientation (this is due to the inversion of the magnetic flux). Take care in handling the busbar and do not over-tighten the nylon screws as this could bend the busbar. Do not use the PCB's Red and Black terminals, they must be left floating when using the busbar. Also note the DC current flow direction shown in Figure 4.