

# SERPAC CXL65D-YY-A-ZZ

Electronic Enclosures

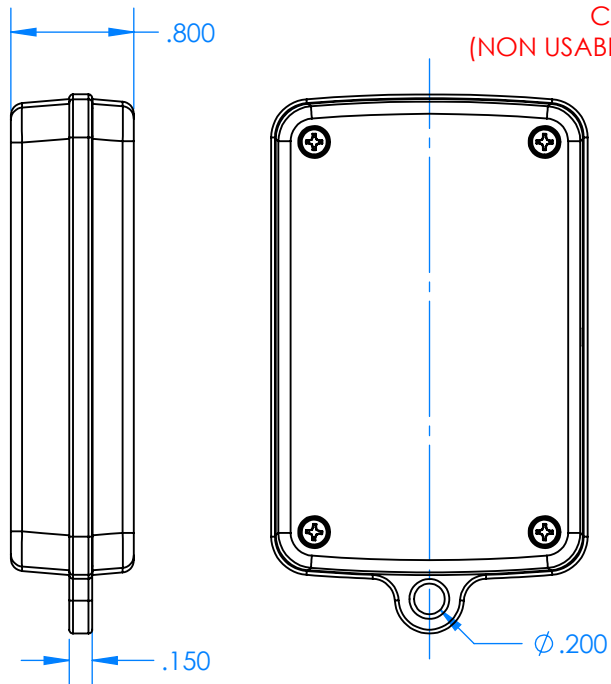

.035 TYP. PCB CLAMP AREA (NON USABLE MARGIN)

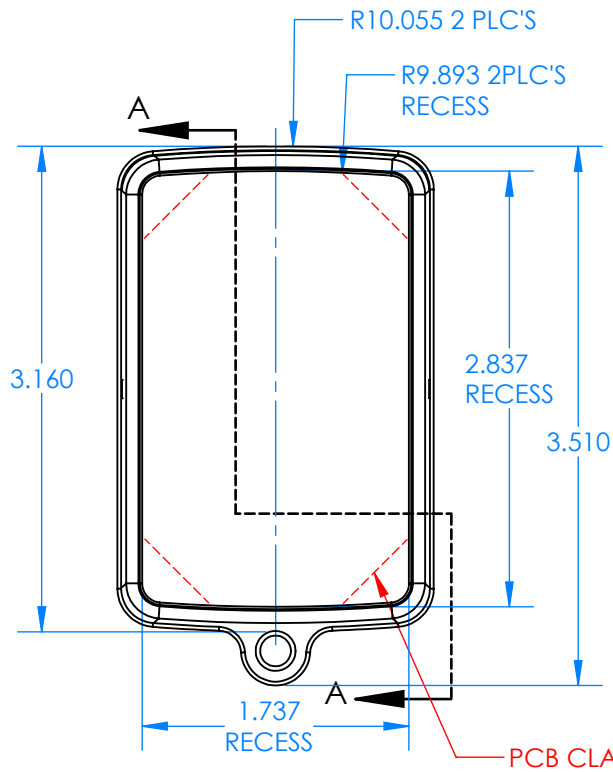
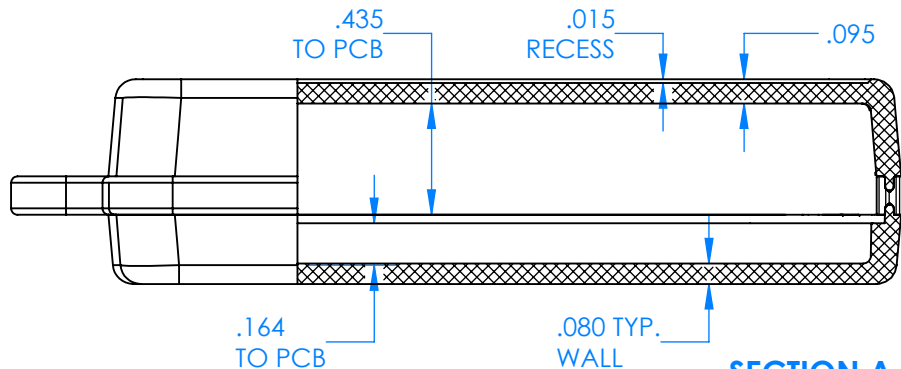
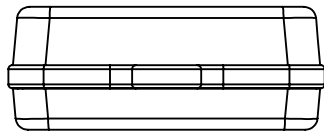
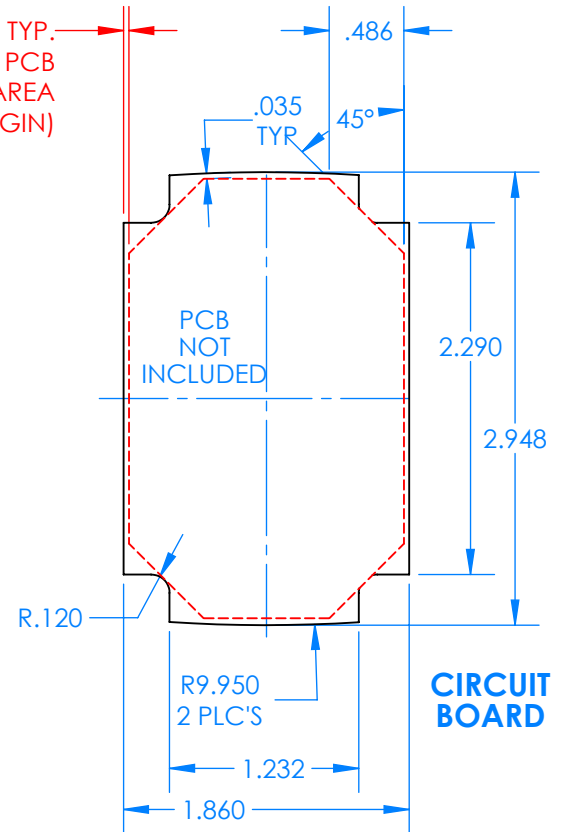

### Enclosure color (YY)

#### Top-Bottom combinations available

- BK=black
- CL=clear
- TRGY=translucent gray
- TRRD=translucent red

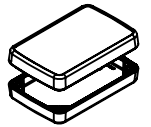

### Seal color (ZZ)

- BK=black
- BL=blue
- GM=gunmetal
- NG=neon green
- NO=neon orange
- OR=orange
- YL=yellow
- WH=white

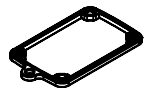

| PN    | Description                                   |
|-------|---|
| 5535D | (1) BW 6C Top style D                         |
| 5534D | (1) BW 6B Bottom style D.                     |
| 5541A | (1) CXL6A Series perimeter seal style A       |
| 6002  | (4) #2 X 3/8" PH HD screw TORQUE 35-60 in-oz. |

Wateright enclosure meets or exceeds:  
**IP67**  
**NEMA 4X, 12, 13**