

EZ-PD™ CCG7DC dual-port USB-C power delivery and DC-DC controller

General description

EZ-PD™ CCG7DC is Infineon highly integrated dual-port USB Type-C power delivery (PD) solution with integrated buck-boost controllers. It complies to the latest USB Type-C and PD specifications, and is targeted for multi-port consumer charging applications. Integration offered by CCG7DC not only reduces the BOM but also provides a footprint optimized solution to support higher power density designs. CCG7DC has integrated gate drivers for VBUS NFET on the provider path. It also includes hardware-controlled protection features on the VBUS. CCG7DC supports a wide input voltage range (4 V to 24 V with 40 V tolerance) and programmable switching frequency (150 kHz to 600 kHz) in an integrated PD solution.

EZ-PD™ CCG7DC is the most programmable USB-PD solution with on-chip 32-bit Arm® Cortex®-M0 processor, 128-KB flash, 16-KB RAM and 32-KB ROM that leaves most flash available for user application use. It also includes various analog and digital peripherals such as ADC, PWMs and Timers. The inclusion of a fully programmable MCU with analog and digital peripherals allows the implementation of custom system management functions such as dynamic load sharing and temperature monitoring.

Applications

- Cigarette lighter adapter (CLA)
- Multi-port AC-DC charger and adapter

Features

- USB-PD
 - Supports two USB-PD ports
 - Supports latest USB-PD 3.0 version 2.0 including programmable power supply (PPS) mode
 - Extended data messaging (EDM)
- Type-C
 - Configurable resistors RP and RD
 - VBUS NFET gate driver
 - Integrated 100-mW VCONN power supply and control
- 2x buck-boost controller
 - 150 kHz to 600 kHz switching frequency
 - 5.5 V to 24 V input, 40 V tolerant
 - 3.3 V to 21.5 V output
 - 20-mV voltage and 50-mA current steps for PPS
 - Supports selectable pulse skipping mode (PSM) and forced continuous conduction mode (FCCM)
 - Supports soft start
 - Programmable spread spectrum frequency modulation for low EMI
 - Programmable phase shift across two ports to further reduce the EMI
- 2x legacy/proprietary charging blocks
 - Supports QC4+, QC4.0, Samsung AFC, Apple 2.4A, and BC v1.2 charging protocols
- Integrated voltage (VBUS) regulation and current sense amplifier (CSA)
 - Integrated shunt regulator function for VBUS control
 - Constant current or constant voltage mode
 - Supports current sensing for constant current control
- System-level fault protection
 - On-chip VBUS, overvoltage protection (OVP), overcurrent protection (OCP), undervoltage protection (UVP)
 - VBUS to CC short protection

Features

- Under-voltage lockout (UVLO)
- Supports over-temperature protection through integrated ADC circuit and internal temperature sensor
- Supports connector and board temperature measurement using external thermistors
- 32-bit MCU subsystem
 - 48-MHz Arm® Cortex®-M0 CPU
 - 128-KB flash
 - 16-KB SRAM
 - 32-KB ROM
- Peripherals and GPIOs
 - 19 GPIOs
 - Two over-voltage GPIOs
 - 3x 8-bit ADC
 - 4x 16-bit timer/counter/PWMs (TCPWM)
- Communication interfaces
 - 4x SCBs (I²C/SPI/UART)
- Clocks and oscillators
 - Integrated oscillator eliminating the need for an external clock
- Power supply
 - 4 V to 24 V input (40-V tolerant)
 - 3.3 V to 21.5 V output
 - Integrated LDO capable of 5 V @ 150 mA
- Packages
 - 68-pin QFN (8 mm × 8 mm) package with -40 °C to +105 °C extended industrial temperature range

Logic block diagram

Logic block diagram

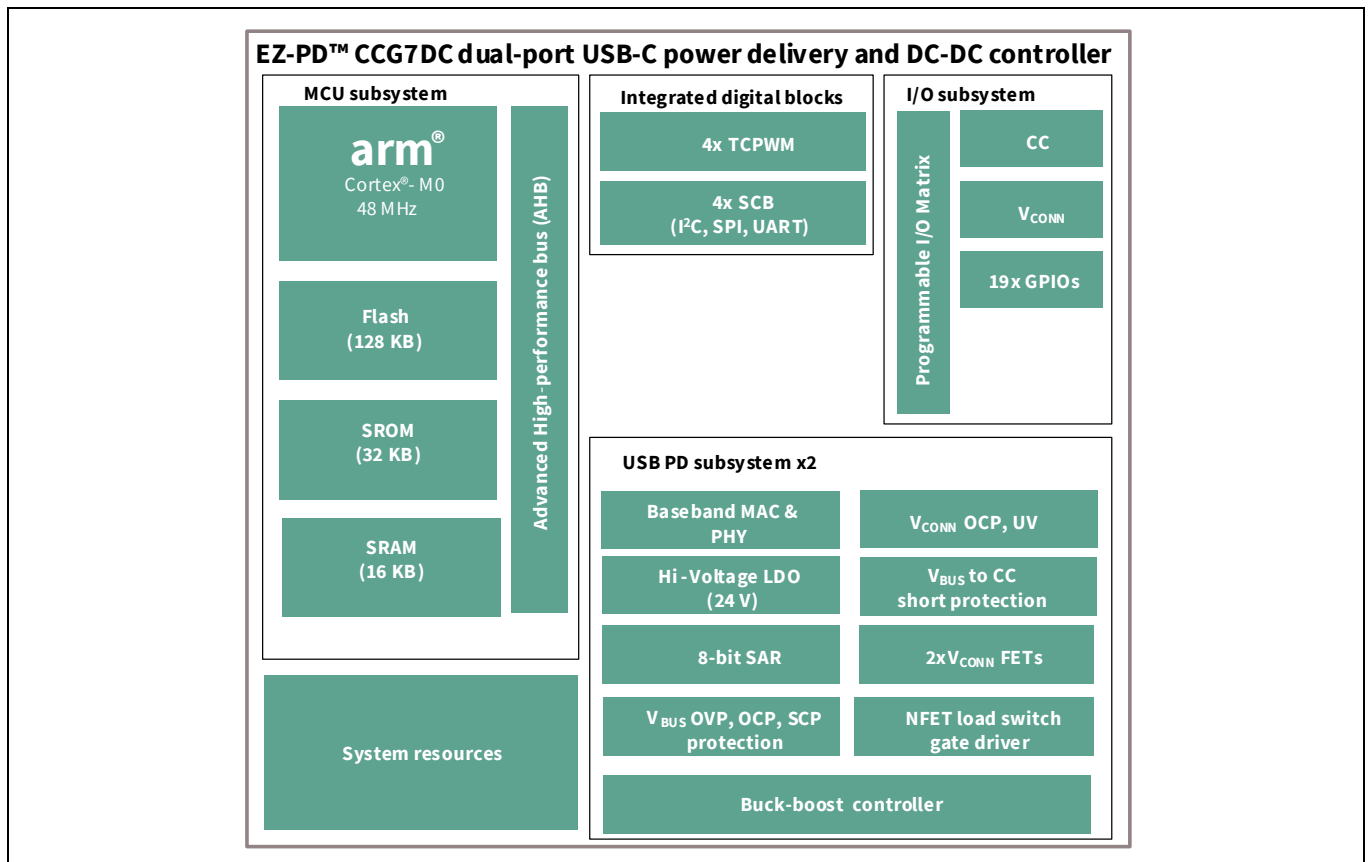

Functional block diagram

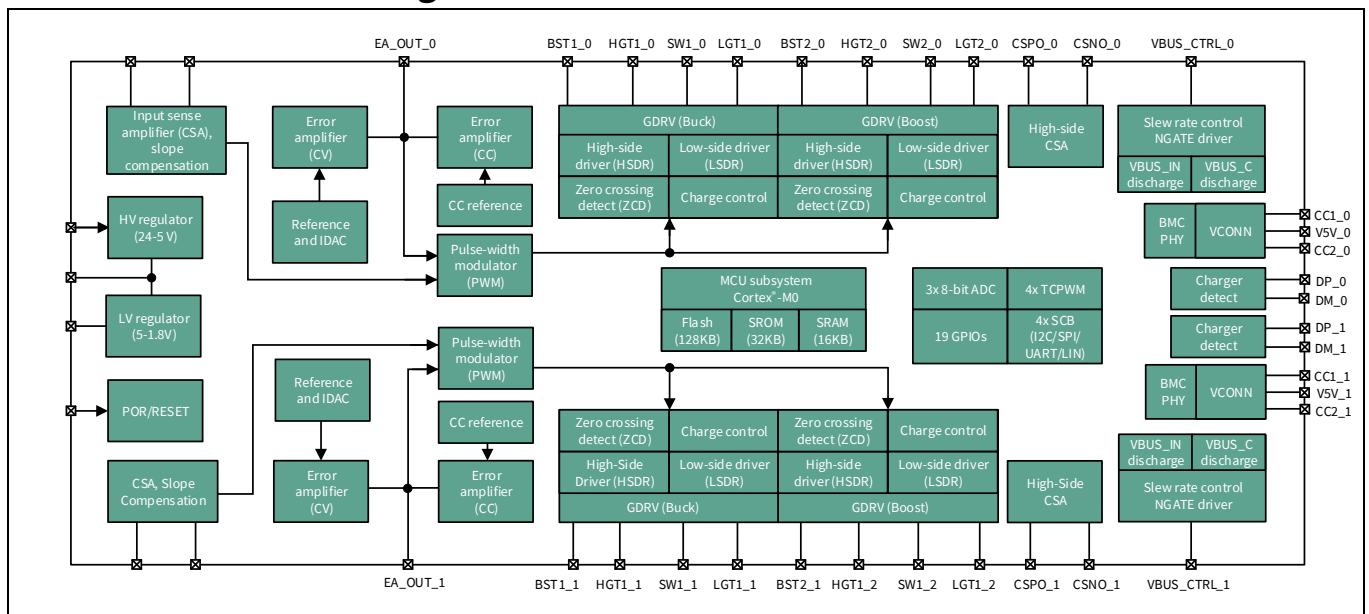

Table of contents

General description	1
Applications	1
Features	1
Logic block diagram	3
Functional block diagram	3
Table of contents	4
1 Functional overview	5
1.1 MCU subsystem.....	5
1.2 USB PD subsystem.....	5
1.3 Buck-boost subsystem	7
1.4 Buck-boost controller operation regions	8
1.5 Analog blocks	11
1.6 Integrated digital blocks.....	11
1.7 I/O subsystem	11
1.8 System resources.....	12
2 Power subsystem	14
2.1 VIN undervoltage lockout (UVLO)	15
2.2 Using external VDDD supply	15
2.3 Power modes	15
3 Pin information	16
4 EZ-PD™ CCG7DC programming and bootloading	21
4.1 Programming the device flash over SWD interface.....	21
5 Applications	22
6 Electrical specifications	26
6.1 Absolute maximum ratings	26
6.2 Device-level specifications	29
6.3 Digital peripherals.....	34
6.4 System resources.....	36
7 Ordering information	42
7.1 Ordering code definitions.....	42
8 Packaging	43
9 Package diagram	44
10 Acronyms	45
11 Document conventions	46
Revision history	47

1 Functional overview

1.1 MCU subsystem

1.1.1 CPU

The Cortex®-M0 in EZ-PD™ CCG7DC devices is a 32-bit MCU, which is optimized for low-power operation with extensive clock gating. It mostly uses 16-bit instructions and executes a subset of the thumb-2 instruction set. It also includes a hardware multiplier, which provides a 32-bit result in one cycle. It includes an interrupt controller (the NVIC block) with 32 interrupt inputs and a wakeup interrupt controller (WIC), which can wake the processor up from deepsleep mode.

1.1.2 Flash ROM and SRAM

EZ-PD™ CCG7DC devices have 128-KB flash and 32-KB ROM for non-volatile storage. ROM stores libraries for authentication and device drivers such as I²C, SPI, and so on. That spares flash for user application. Flash provides the flexibility to store code for any customer feature and allows firmware upgrades to meet the latest USB PD specifications and application needs.

The 16-KB RAM is used under software control to store the temporary status of system variables and parameters. A supervisory ROM that contains boot and configuration routines is provided.

1.2 USB PD subsystem

This subsystem provides the interface to the Type-C USB port. This subsystem comprises:

- USB PD physical layer
- VCONN switches
- Under voltage (UVP), over voltage (OVP) on VBUS
- Output high-side CSA (HS CSA) for VBUS
- VBUS discharge control
- Gate driver for VBUS provider NFET
- Charger detection block for legacy charging
- VBUS to CC short-circuit protection

1.2.1 USB PD physical layer

The USB PD subsystem contains the USB PD physical layer block and supporting circuits. The USB PD physical layer consists of a transmitter and receiver that communicate BMC encoded data over the CC channel per the PD 3.0 standard. All communication is half-duplex. The physical layer or PHY practices collision avoidance to minimize communication errors on the channel.

Also, the USBPD block includes all termination resistors (Rp and Rd) and their switches as required by the USB Type-C spec. Rp and Rd resistors are required to implement connection detection, plug orientation detection and for the establishment of the USB source/sink roles. The Rp resistor is implemented as a current source.

CCG7DC device family is fully complaint with revisions 3.0 and 2.0 of the USB PD specification. The device supports PPS operation at all valid voltages from 3.3 V to 21 V.

CCG7DC devices support Rp under HW control in unconnected (standby) state to minimize standby power.

CCG7DC devices support USB-PD extended messages containing data of up to 260 bytes. The extended messages are larger than expected by USB-PD 2.0 hardware. As per the USB-PD protocol specification, USB-PD 3.0 compliant devices implement a Chunking mechanism; messages are limited to Revision 2.0 sizes unless both source and sink confirm and negotiate compatibility with longer message lengths.

1.2.2 VCONN switches

EZ-PD™ CCG7DC's internal LDO voltage regulator is capable of powering a 100mW VCONN supply for electronically marked cable assemblies (EMCA), VCONN-powered devices (VPD), and VCONN-powered accessories as defined in the USB Type-C specification. All circuitry including VCONN switches and over-current protection is integrated in the device. In the event the VCONN current exceeds the VCONN OCP limit, CCG7DC can be configured to shut down the Type-C port after a certain number of user configurable retries. The port can be re-enabled after a physical disconnect.

1.2.3 VBUS UVP and OVP

VBUS undervoltage and overvoltage faults are monitored using internal resistor dividers. The fault thresholds and response times are user configurable. Refer to the [EZ-PD™ Configuration Utility](#) for more details. In the event of a UVP or OVP, CCG7DC can be configured to shut down the Type-C port after a certain number of user configurable retries. The port can be re-enabled after a physical disconnect.

1.2.4 VBUS OCP and SCP

VBUS overcurrent and short-circuit faults are monitored using internal CSAs. Similar to OVP and UVP, the OCP and SCP fault thresholds and response times are configurable as well. Refer to the [EZ-PD™ Configuration Utility](#) for more details. In the event of OCP or SCP, CCG7DC can be configured to shut down the Type-C port after a certain number of user configurable retries. The port can be re-enabled after a physical disconnect.

1.2.5 HS-CSA for VBUS

EZ-PD™ CCG7DC device family supports VBUS current measurement and control using an external resistor (5 mΩ) in series with the VBUS path. The voltage drop across this resistor is used to measure the average output current. The same resistor is also used to sense and precisely control the output current in the PPS current foldback mode of operation.

1.2.6 VBUS discharge control

The chip supports high-voltage (21.5 V) VBUS discharge circuitry. Upon the detection of device disconnection, faults, or hard resets, the chip will discharge the output VBUS terminals to vSafe5 V and/or vSafe0V within the time limits specified in the USB PD specification.

1.2.7 Gate driver for VBUS provider NFET

EZ-PD™ CCG7DC devices have an integrated high-voltage gate driver to drive the gate of an external high-side NFET on the VBUS provider path. The gate driver drives the load switch that controls the connection between VBUS_IN and VBUS_C. VBUS_CTRL is the output of this gate driver. To turn off the external NFET, the gate driver drives VBUS_IN low. To turn on the external NFET, it drives the gate to VBUS_IN + 8 V. There is an optional slow turn-on feature which is meant to avoid sudden in-rush current. For a typical gate capacitance of 3-nF, a slow turn-on time of 2 ms to 10 ms is configurable using firmware.

1.2.8 Legacy charge detection and support

The chip implements battery charger emulation and detection (source and sink) for USB BC.1.2, legacy Apple charging, Qualcomm quick charge 2.0/3.0, Samsung AFC protocols and several upcoming proprietary charging protocols.

1.2.9 VBUS to CC short protection

EZ-PD™ CCG7DC's CC pins have integrated protection from accidental shorts to high-voltage VBUS. CCG7DC devices can handle up to 24 V external voltage on its CC pins without damage. In the event an over-voltage is detected on the CC pin, CCG7DC can be configured to shut down the Type-C port completely. The port will resume normal operation once the CC voltage detected is within normal range.

1.3 Buck-boost subsystem

The buck-boost subsystem in EZ-PD™ CCG7DC devices can be configured to operate in buck-boost mode, buck-only mode or boost-only mode. While buck-boost mode requires four external switching FETs, buck-only and boost-only modes require only two FETs. Buck-only mode is useful when CCG7DC device's port is used for multi-port AC/DC designs. **Figure 1** illustrates the buck-boost subsystem's main external components and connections.

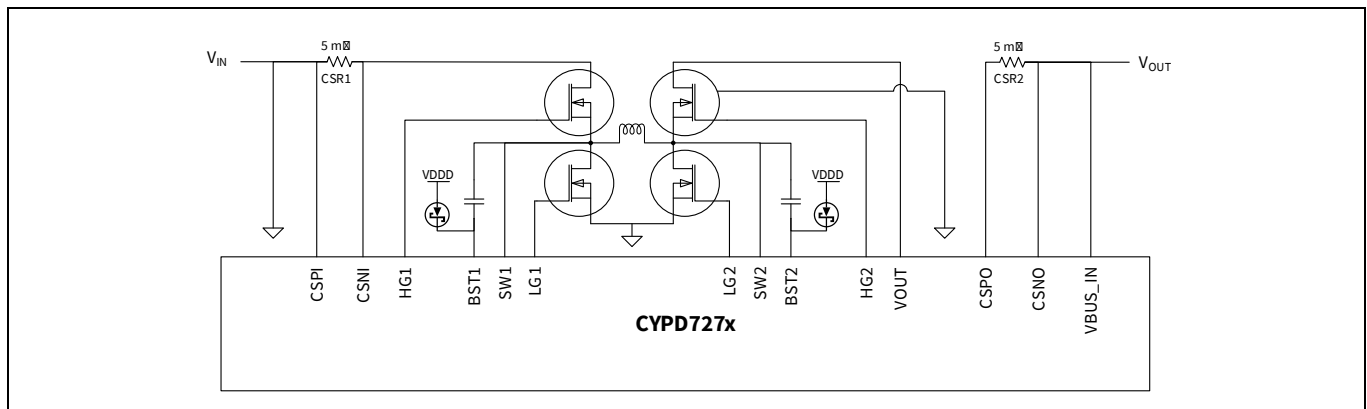

Figure 1 Buck-boost schematic showing external components

Buck-boost subsystem in EZ-PD™ CCG7DC devices have the following key functional blocks:

- High-side (cycle-by-cycle) CSA
- High-side and low-side gate driver
- Pulse-width modulator (PWM)
- Error amplifier (EA)

1.3.1 High-side (cycle-by-cycle) CSA

EZ-PD™ CCG7DC device's buck-boost controller implements peak current control in both boost and buck modes. A high-side CSA is used for peak current sensing through an external resistor (5 mΩ; see CSR1 in **Figure 1**) placed in series with the buck control FET. This CSA is high bandwidth and very wide common mode amplifier. This current sense resistor is connected to the CSA block through pins CSPI and CSNI as shown in **Figure 1**. This block implements slope compensation to avoid sub-harmonic oscillation for the internal current loop. In addition to peak current sensing, it provides a current limit comparator for shutting off the buck-boost converter if the current hits an upper threshold which is programmable.

1.3.2 High-side gate driver and low-side gate driver (HG/LG)

EZ-PD™ CCG7DC's buck-boost controller provides four N-channel MOSFET gate drivers: two floating high-side gate drivers at the HG1 and HG2 pins, and two ground referenced low-side drivers at the LG1 and LG2 pin. The high-side gate drivers drive the high-side external FET with a nominal VGS of 5 V. The high-side gate driver has a programmable drive strength to drive external FET. An external capacitor and Schottky diode form a bootstrap network to collect and store the high voltage source ($V_{IN} + \sim 5$ V for HG1 and $V_{BUS} + \sim 5$ V for HG2) needed to drive the high-side FET.

The low-side gate driver drives the low-side external FET with a nominal VGS of 5 V using energy sourced from CCG7DC's internal LDO regulator and stored in the capacitor between PVDD and PGND. Low-side gate driver has programmable drive strength to drive external FET.

Functional overview

In addition to drive strength, the high-side gate driver and the low-side gate driver have programmable options for deadtime control and zero-crossing levels. High-side gate driver and low-side gate driver blocks include zero-crossing detector (ZCD) to implement discontinuous-conduction mode (DCM) mode with diode emulation.

The gate drivers for the switching FETs function at their nominal drive voltage levels (5 V) provided the VIN voltage is between 5.5 V and 24 V.

1.3.3 Error amplifier (EA)

EZ-PD™ CCG7DC's buck-boost controller contains two error amplifiers for output voltage and current regulation. The error amplifier is a trans-conductance type amplifier with single compensation pin (COMP) to ground for both the voltage and current loops. In voltage regulation, the output voltage is compared with the internal reference voltage and the output of EA is fed to the PWM block. In current regulation, the average current is sensed by VBUS high-side CSA through the external resistor. The output of the VBUS CSA is compared with internal reference in error amplifier block and EA output is fed to the PWM block. CCG7DC devices negotiate a power delivery contract over the Type-C port in compliance to USB-PD specification with the peer sink device and in turn controls the EA output through the integrated programmable error amplifier circuit for achieving the required VBUS voltage output.

1.3.4 Pulse-width modulator (PWM)

EZ-PD™ CCG7DC device family's PWM block generates the control signals for the gate drivers driving the external FETs in peak current mode control. There are many programmable options for minimum/maximum pulse width, minimum/maximum period, frequency and pulse skip levels to optimize the system design.

CCG7DC devices have two firmware-selectable operating modes to optimize efficiency and reduce losses under light load conditions: PSM and FCCM. It is critical in charger applications where the load can vary from a few watts to 100 W.

1.3.5 Pulse skipping mode (PSM)

In pulse skipping mode, the controller reduces the total number of switching pulses without reducing the active switching frequency by working in “bursts” of normal nominal-frequency switching interspersed with intervals without switching. The output voltage thus increases during a switching burst and decreases during a quiet interval. This mode results in minimal losses at the cost of higher output voltage ripple. When in this mode, EZ-PD™ CCG7DC devices monitor the voltage across the buck or boost sync FET to detect when the inductor current reaches zero; when this occurs, the CCG7DC devices switch off the buck or boost sync FET to prevent reverse current flow from the output capacitors (i.e. diode emulation mode). Several parameters of this mode are programmable through firmware, allowing the user to strike their own balance between light load efficiency and output ripple.

1.3.6 Forced continuous conduction mode (FCCM)

In forced continuous conduction mode, the nominal switching frequency is maintained at all times, with the inductor current going below zero (i.e. “backwards” or from the output to the input) for a portion of the switching cycle as necessary to maintain the output voltage and current. This keeps the output voltage ripple to a minimum at the cost of light-load efficiency.

1.4 Buck-boost controller operation regions

The CSA output is compared with the output of the error amplifier to determine the pulse width of the PWM. PWM block compares the Input voltage and output voltage to determine the buck, boost, and buck-boost regions. The switching time/period of the four gate drivers (HG1, LG1, HG2, LG2) depends upon the region in which the block is operating as well as the mode such as DCM or FCCM. The exact VIN vs VOUT thresholds for transitions into and out of each region are adjustable in firmware including the hysteresis.

1.4.1 Buck region operation ($V_{IN} \gg V_{BUS}$)

When the V_{IN} voltage is significantly higher than the required V_{BUS} voltage, EZ-PD™ CCG7DC devices operate in the buck region. In this region, the boost side FETs are inactivated, with the boost control FET (connected to LG2) turned off and the boost sync FET (connected to HG2) turned on. The buck side FETs are controlled as a buck converter with synchronous rectification as shown in [Figure 2](#). Depending on the application and requirement the device can be configured to operate in buck mode only at all times using only two FETs.

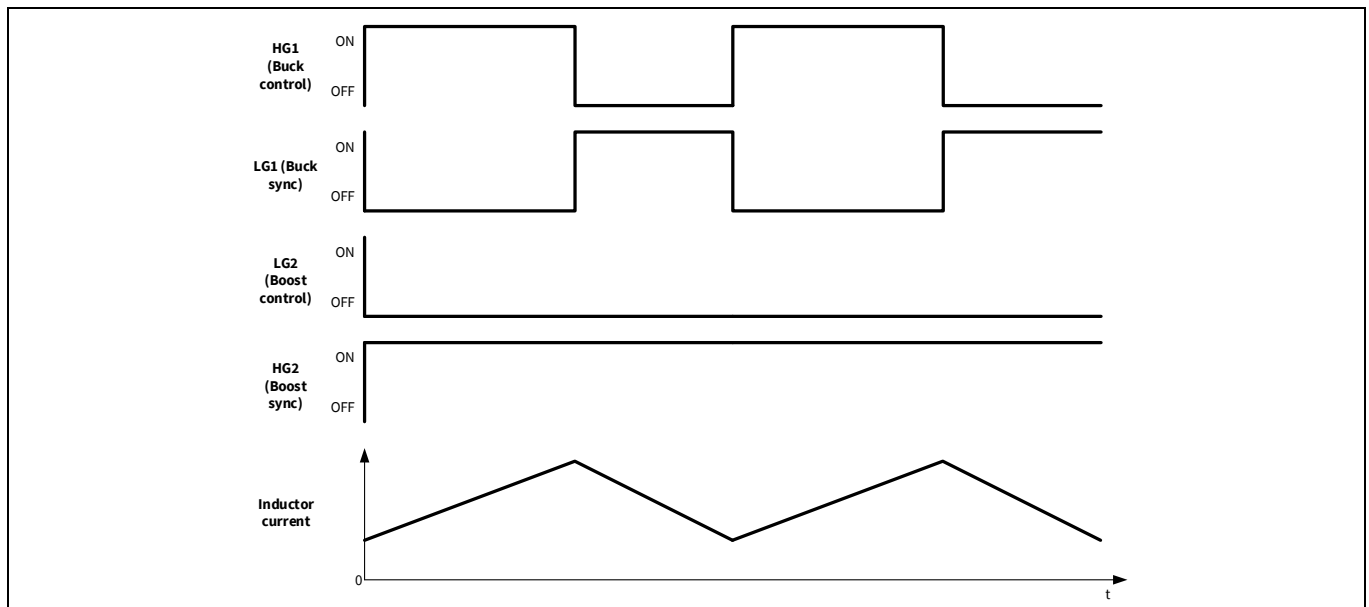

Figure 2 Buck operation waveforms

1.4.2 Boost region operation ($V_{IN} \ll V_{BUS}$)

When the V_{IN} voltage is significantly lower than the required V_{BUS} voltage, EZ-PD™ CCG7DC devices operate in the boost region. In this region, the buck side FETs are inactivated, with the sync FET turned OFF and the buck control FET turned ON. The boost side FETs are controlled as a boost converter with synchronous rectification as shown in [Figure 3](#).

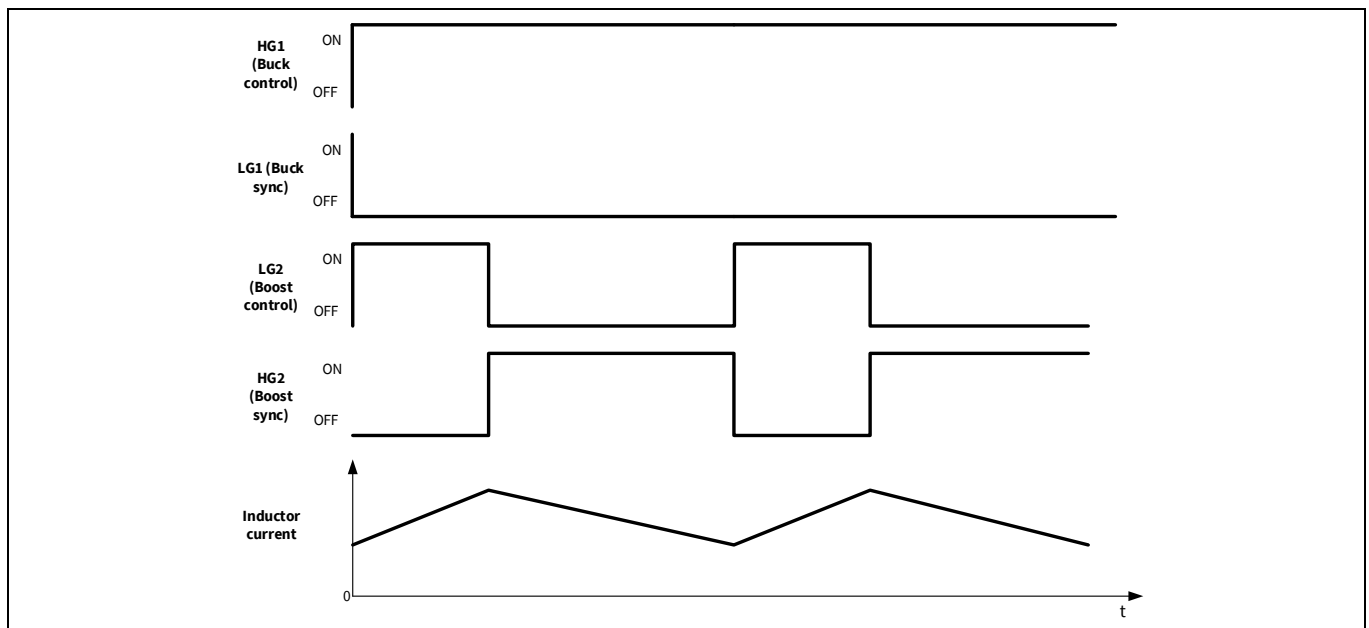

Figure 3 Boost operation waveforms

1.4.3 Buck-boost region 1 operation ($V_{IN} \sim V_{BUS}$)

When the V_{IN} voltage is slightly higher than the required V_{BUS} voltage, EZ-PD™ CCG7DC devices operate in the buck-boost region 1. In this region, the boost side FET (LG2) works at a fixed 20% duty cycle (programmable) while the buck side (LG1 / HG1) duty cycle is modulated to control the output voltage. All four FETs are switching every cycle in this operating region as shown in [Figure 4](#).

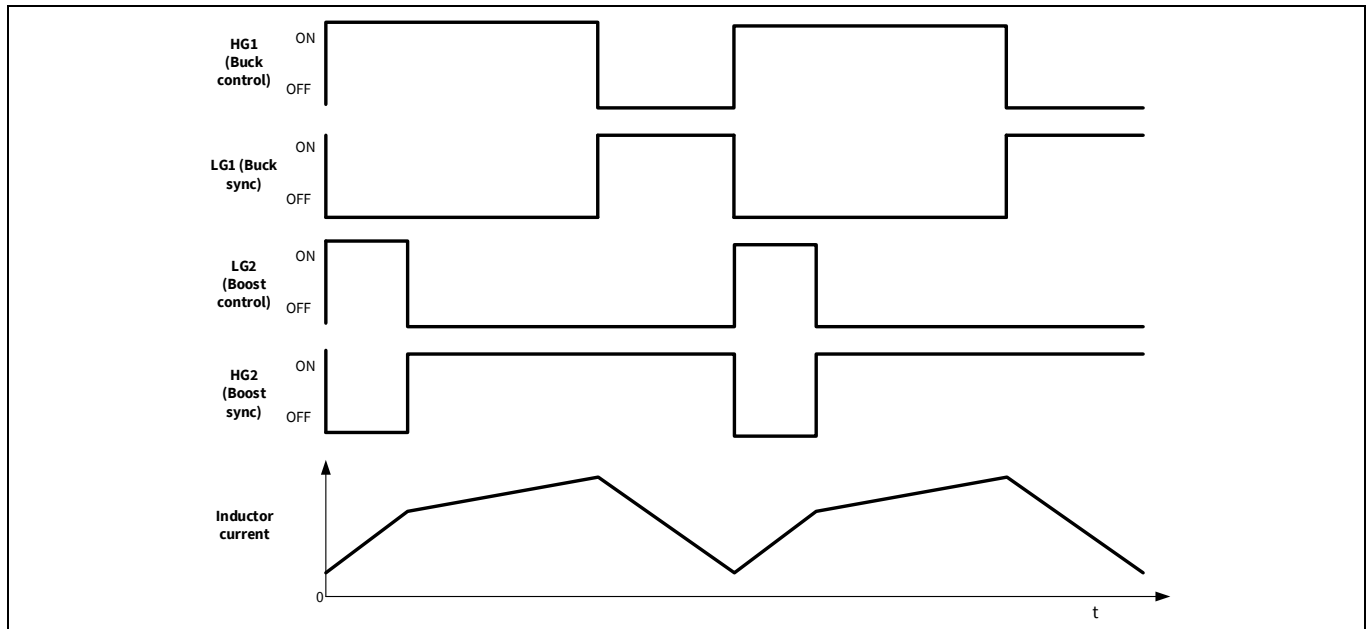

Figure 4 Buck-boost region 1 ($V_{IN} \sim V_{BUS}$) operation waveforms

1.4.4 Buck-boost region 2 operation ($V_{IN} \sim < V_{BUS}$)

When the V_{IN} voltage is slightly lower than the required V_{BUS} voltage, EZ-PD™ CCG7DC devices operate in the buck-boost region 2. In this region, the buck side (HG1) works at a fixed 80% duty cycle (programmable) while the boost side (LG2) duty cycle is modulated to control the output voltage. All four FETs are switching every cycle in this operating region as shown in [Figure 5](#).

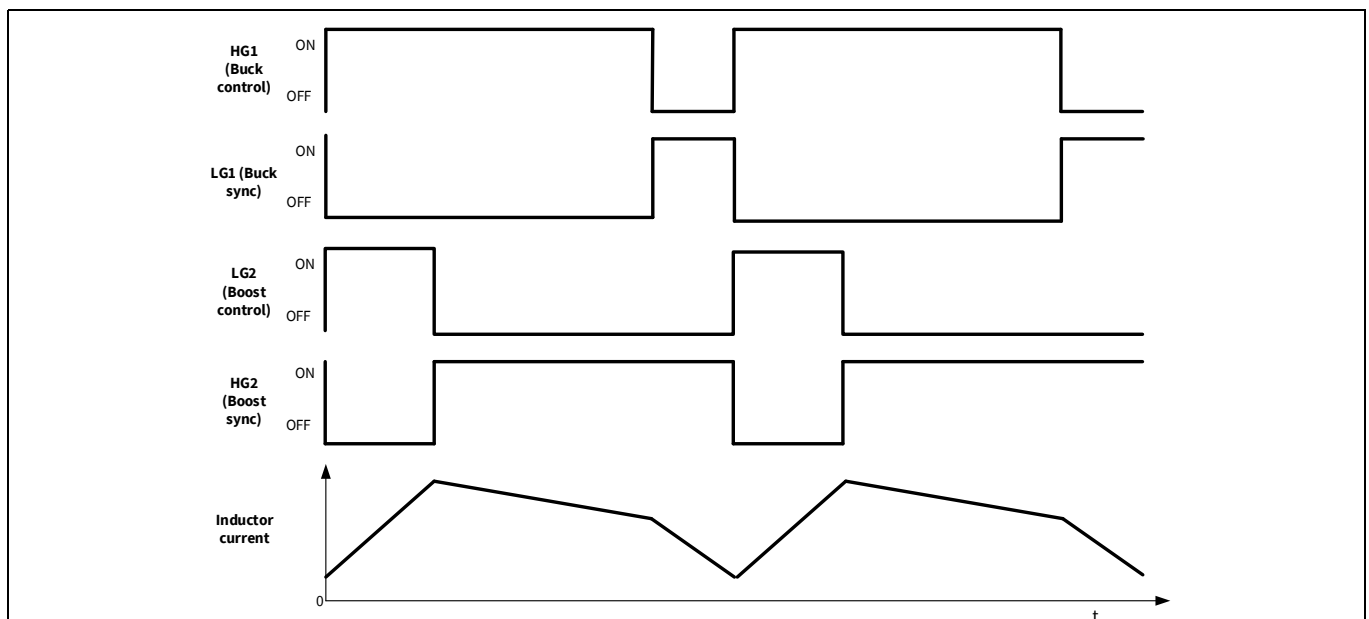

Figure 5 Buck-boost region 2 ($V_{IN} \sim < V_{BUS}$) operation waveforms

1.4.5 Switching frequency and spread spectrum

EZ-PD™ CCG7DC devices offer programmable switching frequency between 150 kHz and 600 kHz. The controller supports spread spectrum clocking within the operating frequency range in all operating modes. Spread spectrum is essential for charging applications to meet EMC/EMI requirements by spreading emissions caused by switching over a wide spectrum instead of a fixed frequency, thereby reducing the peak energy at any particular frequency. Both the switching frequency and the spread spectrum span are firmware programmable.

1.5 Analog blocks

1.5.1 ADC

CCG7DC devices family have three 8-bit SAR ADCs available for general purpose A-D conversion applications in the chip. The ADCs can be accessed from the GPIOs through an on-chip analog mux. See [Table 27](#) for detailed specs on the ADCs.

1.6 Integrated digital blocks

1.6.1 Serial communication block (SCB)

EZ-PD™ CCG7DC devices have four SCB blocks that can be configured for I²C, SPI, or UART. These blocks implement full multi-master and slave I²C interfaces capable of multi-master arbitration. I²C is compatible with the standard Philips I²C specification v3.0. These blocks operate at speeds of up to 1 Mbps and have flexible buffering options to reduce interrupt overhead and latency for the CPU. The SCB blocks support 8-byte deep FIFOs for receive and transmit, which, by increasing the time given for the CPU to read data, greatly reduces the need for clock stretching caused by the CPU not having read data on time. The I²C port I/Os for SCB0 are over-voltage tolerant (OVT). The I²C ports for SCB1-3 are not OVT compliant.

1.6.2 Timer, counter, pulse-width modulator (TCPWM)

The TCPWM block of EZ-PD™ CCG7DC devices support four timers or counters or pulse-width modulators. These timers are available for internal timer use by firmware or for providing PWM-based functions on the GPIOs.

1.7 I/O subsystem

The EZ-PD™ CCG7DC devices have 19 GPIOs including the I2C and SWD pins which can also be used as GPIOs. The GPIO block implements the following:

- Eight drive strength modes
 - Input only
 - Weak pull-up with strong pull-down
 - Strong pull-up with weak pull-down
 - Open drain with strong pull-down
 - Open drain with strong pull-up
 - Strong pull-up with strong pull-down
 - Disabled
 - Weak pull-up with weak pull-down
- Input threshold select (CMOS or LVTTTL)
- Individual control of input and output disables
- Hold mode for latching previous state (used for retaining I/O state in Deep Sleep mode)
- Selectable slew rates for dV/dt related noise control.
- OVT on one pair of GPIOs

During power-on and reset, the blocks are forced to the disable state so as not to crowbar any inputs and/or cause excess turn-on current. A multiplexing network known as a high-speed I/O matrix (HSIOM) is used to multiplex

Functional overview

between various signals that may connect to an I/O pin. Pin locations for fixed-function peripherals such as USB Type-C port are also fixed in order to reduce internal multiplexing complexity. Data Output registers and Pin State register store, respectively, the values to be driven on the pins and the states of the pins themselves. The configuration of the pins can be done by the programming of registers through software for each digital I/O port.

Every I/O pin can generate an interrupt if so enabled and each I/O port has an interrupt request (IRQ) and interrupt service routine (ISR) vector associated with it.

The I/O ports can retain their state during deepsleep mode or remain ON. If the operation is restored using reset, then the pins shall go the high-Z state. If operation is restored by an interrupt event, then the pin drivers shall retain their state until firmware chooses to change it. The IOs (on data bus) do not draw current on power down.

1.8 System resources

1.8.1 Watchdog timer (WDT)

EZ-PD™ CCG7DC devices have a watchdog timer running from the internal low-speed oscillator (ILO). This allows watchdog operation during deepsleep and generate a watchdog reset if not serviced before the timeout occurs. The watchdog reset is recorded in the Reset Cause register.

1.8.2 Reset

EZ-PD™ CCG7DC devices can be reset from a variety of sources including a software reset. Reset events are asynchronous and guarantee reversion to a known state. The Reset cause is recorded in a register, which is sticky through reset and allows software to determine the cause of the reset. XRES pin is the dedicated pin for reset to apply hardware reset.

1.8.3 Clock system

CCG7DC devices have a fully integrated clock with no external crystal required. CCG7DC device's clock system is responsible for providing clocks to all sub-systems that require clocks (SCB and PD) and for switching between different clock sources, without glitches.

The HFCLK signal can be divided down as shown to generate synchronous clocks for the digital peripherals. The clock dividers have 8-bit, 16-bit and 16-bit fractional divide capability. The 16-bit capability allows a lot of flexibility in generating fine-grained frequency values. The clock dividers generate either enabled clocks (that is, 1 in N clocking where N is the divisor) or an approximately 50% duty cycle clock (exactly 50% for even divisors, one clock difference in the high and low values for odd divisors).

In [Figure 6](#), PERXYZCLK represents the clocks for different peripherals.

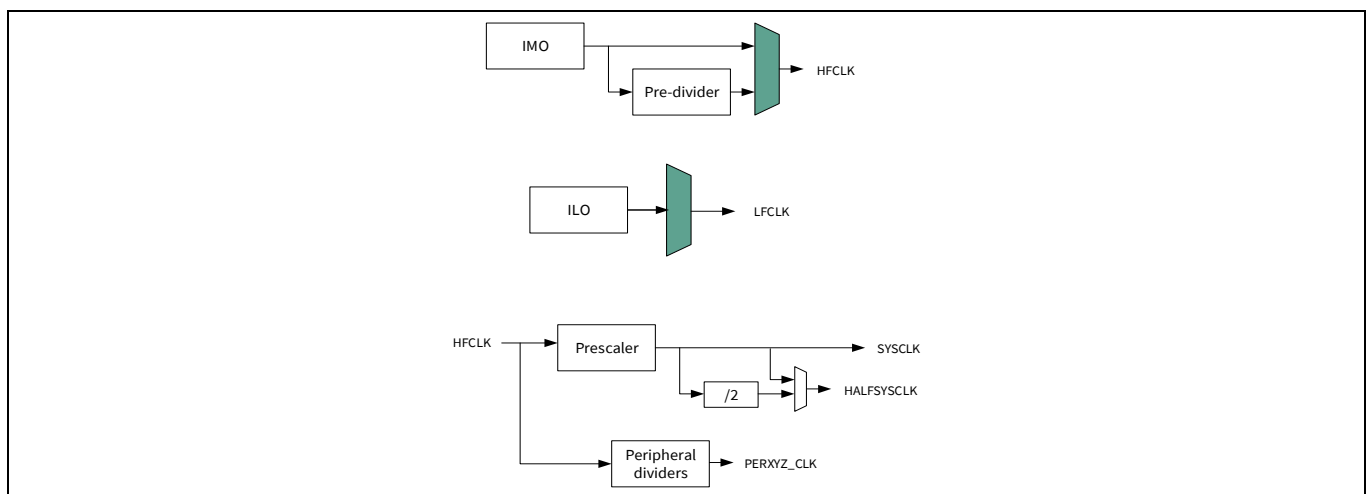

Figure 6 Clocking architecture of EZ-PD™ CCG7DC devices

1.8.4 Internal main oscillator (IMO) clock source

The internal main oscillator is the primary source of internal clocking in CCG7DC devices. IMO default frequency for CCG7DC devices is 48 MHz \pm 2%.

1.8.5 ILO clock source

The internal low-speed oscillator is a very low power, relatively inaccurate, oscillator, which is primarily used to generate clocks for peripheral operation in USB suspend (deepsleep) mode.

2 Power subsystem

Figure 7 illustrates an overview of the power subsystem architecture for EZ-PD™ CCG7DC devices. The power subsystem of CCG7DC devices operate from VIN supply which can vary from 4 V to 24 V. The VDDD pin, the output of 5 V LDO gets input from VIN supply. The VDDD pin can also be used as a power supply for external loads up to 150 mA. CCG7DC devices have two different power modes: Active and deepsleep, transitions between which are managed by the power system. The VCCD pin, the output of the core (1.8 V) regulator, is brought out for connecting a 0.1- μ F capacitor for the regulator stability only. This pin is not supported as a power supply for external load.

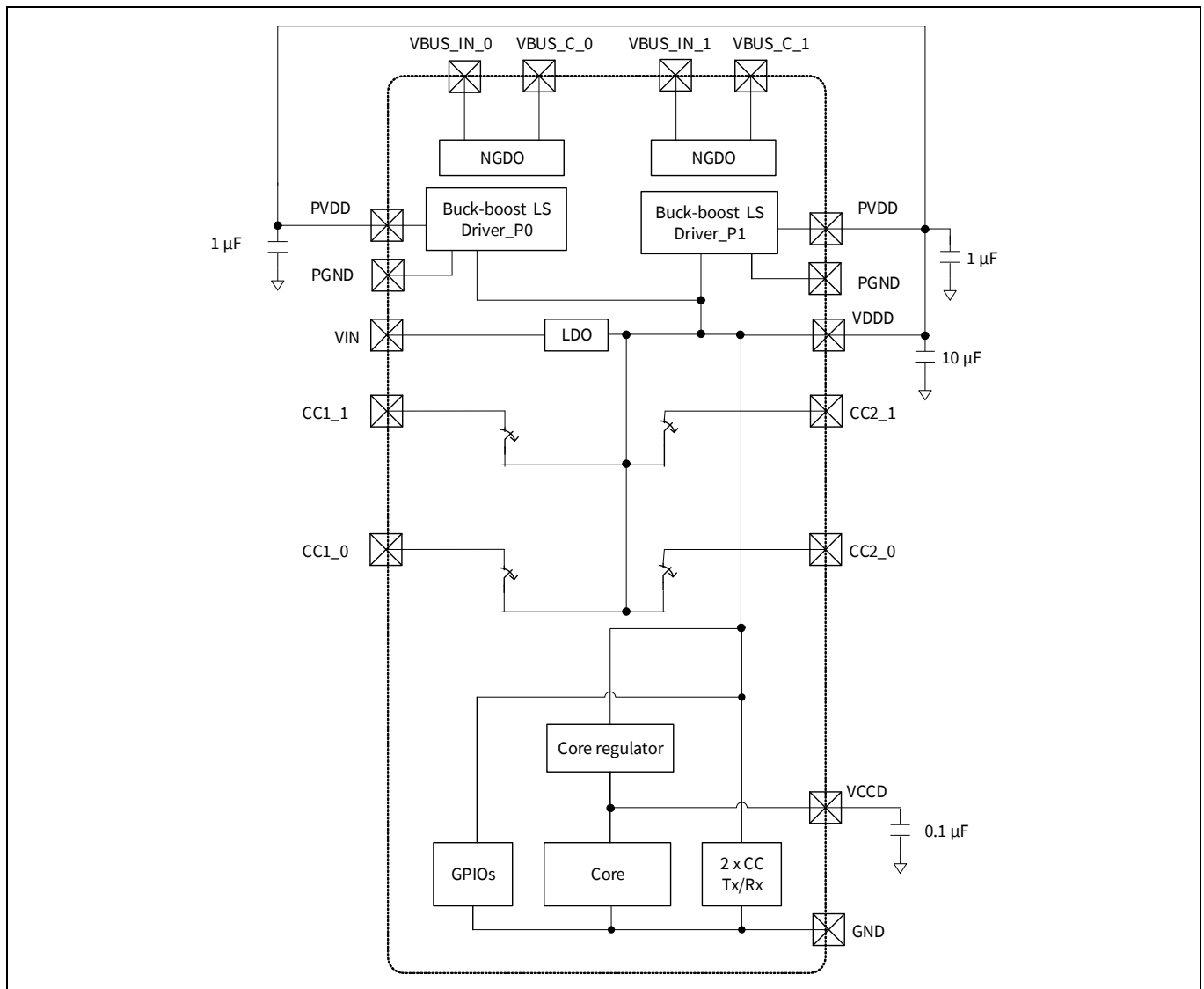

Figure 7 Power system requirement block diagram

2.1 VIN undervoltage lockout (UVLO)

EZ-PD™ CCG7DC supports UVLO to allow the device to shut down when the input voltage is below the reliable level. It guarantees predictable behavior when the device is up and running.

2.2 Using external VDDD supply

By default, external VDDD is not supported for CCG7DC devices. However, usage of external VDDD supply can be enabled using firmware. The pre-requisite for enabling external forcing of VDDD is to always maintain VIN higher than VDDD and the external load on VDDD pin of CCG7DC devices should never be higher than prescribed load capability of internal VDDD LDO.

2.3 Power modes

The power modes of the device accessible and observable by the user are shown in [Table 1](#).

Table 1 Power modes

Mode	Description
RESET	Power is valid and XRES is not asserted. An internal reset source is asserted or sleep controller is sequencing the system out of reset.
ACTIVE	Power is valid and CPU is executing instructions.
SLEEP	Power is valid and CPU is not executing instructions. All logic that is not operating is clock gated to save power.
DEEPSLEEP	Main regulator and most hard-IP are shut off. Deepsleep regulator powers logic, but only low-frequency clock is available.
XRES	Power is valid and XRES is asserted. Core is powered down.

3 Pin information

Table 2 EZ-PD™ CCG7DC pinout table

Pin#	Pin name	GPIO port	Description
1	SW1_0	-	Negative power rail of port 0 buck high-side gate driver. This is also connected to one input terminal of zero current detection of buck low-side gate driver. Connect to the switch node (inductor) on the buck (input) side. Use a short and wide trace to minimize the inductance and resistance of this connection.
2	LG1_0		Buck low-side gate driver output of port 0. Connect to the buck (input) side sync (low-side) FET gate. Use a wide trace to minimize inductance of this connection.
3	PGND_0		Ground of low-side gate driver of port 0. This is also connected to one input terminal of ZCD of buck low-side gate driver. Connect directly to port 0's board ground plane.
4	PVDD_0		Supply of low-side gate driver of port 0. Connect to VDDD. Use 1- μ F and 0.1- μ F bypass capacitors as close to the CCG7DC IC as possible.
5	LG2_0		Boost low-side gate driver output of port 0. Connect to the boost (output) side control (low-side) FET gate. Use a wide trace to minimize inductance of this connection.
6	VOUT_0		Output of the buck-boost converter of port 0. This is also connected to one input terminal of reverse current protection of boost high-side gate driver. Connect to the boost sync (high-side) FET's drain. Use a dedicated (Kelvin) trace for this connection.
7	SW2_0		Negative power rail of port 0 boost high-side gate driver. This is also connected to one input terminal of reverse current protection of boost high-side gate driver. Connect to the switch node (inductor) on the boost (output) side. Use a short and wide trace to minimize the inductance and resistance of this connection.
8	HG2_0		Boost high-side gate driver output of port 0. Connect to the boost (output) side sync (high-side) FET gate. Use a wide trace to minimize inductance of this connection.
9	BST2_0		Boosted power supply of port 0 boost high-side gate driver. Bootstrap capacitor node. Connect Schottky diode from VDDD to BST2_0. Also, connect a bootstrap capacitor from this pin to SW2_0.
10	COMP_0		EA output pin of port 0. Connect a compensation network to GND. Contact Infineon for assistance in designing the compensation network.
11	CSPO_0		Positive input of output CSA of port 0. Connect to positive terminal of the output current sense resistor.
12	CSNO_0		Negative input of output CSA of port 0. Connect to negative terminal of the output current sense resistor.
13	VBUS_IN_0		Input of feedback voltage of EA of port 0. Connect to the VBUS node between the output current sense resistor and the VBUS Provider NFET.
14	VBUS_C_0		Type-C connector VBUS voltage of port 0. Connect to the Type-C connector's VBUS pin.
15	CC1_0		Type-C connector configuration channel 1 of port 0. Connect directly to the CC1 pin on the port's Type-C connector. Also connect a 390-pF capacitor to ground.
16	CC2_0		Type-C connector configuration channel 2 of port 0. Connect directly to the CC2 pin on the port's Type-C connector. Also connect a 390-pF capacitor to ground.
17	VBUS_CTRL_0		VBUS NFET gate driver output of port 0. Connect to the provider NFET's gate.

Pin information

Table 2 EZ-PD™ CCG7DC pinout table (continued)

Pin#	Pin name	GPIO port	Description
18	CSN_0_GPIO0	P0.0	GPIO
19	CSP_0_GPIO1	P0.1	
20	GPIO2	P0.2	
21	GPIO3	P0.3	
22	GPIO4	P0.4	
23	DP_0_GPIO5	P1.0	USB D+ of port 0/GPIO: D+ for implementing BC 1.2, AFC, QC or Apple Charging. CCG7DC does not support USB data transmission on this pin.
24	DM_0_GPIO6	P1.1	USB D- of port 0/GPIO: D- for implementing BC 1.2, AFC, QC or Apple Charging. CCG7DC does not support USB data transmission on this pin.
25	VDDD	-	5-V LDO output. Connect a 1- μ F ceramic bypass capacitor to this pin. Also, connect this pin directly to pin 63.
26	DM_1_GPIO7	P1.2	USB D- of port 1/GPIO: D- for implementing BC 1.2, AFC, QC or Apple Charging. CCG7DC does not support USB data transmission on this pin.
27	DP_1_GPIO8	P1.3	USB D+ of port 1/ GPIO: D+ for implementing BC 1.2, AFC, QC or Apple Charging. CCG7DC does not support USB data transmission on this pin.
28	XRES	-	External reset – active low. Contains a 3.5 k Ω to 8.5 k Ω internal pull-up.
29	GPIO9	P2.0	GPIO
30	GPIO10	P2.1	
31	GPIO11	P1.4	
32	CSP_1_GPIO12	P1.5	
33	CSN_1_GPIO13	P1.6	

Pin information

Table 2 EZ-PD™ CCG7DC pinout table (continued)

Pin#	Pin name	GPIO port	Description
34	GND	-	Chip ground. Connect directly to the exposed pad (EPAD) and to pin 64.
35	VBUS_CTRL_1		VBUS NFET gate driver output of port 1. Connect to the provider NFET's gate.
36	CC2_1		Type-C connector configuration channel 2 of port 1. Connect directly to the CC2 pin on the port's Type-C connector. Also connect a 390-pF capacitor to ground.
37	CC1_1		Type-C connector configuration channel 1 of port 1. Connect directly to the CC1 pin on the port's Type-C connector. Also connect a 390-pF capacitor to ground.
38	VBUS_C_1		Type-C connector BUS voltage of port 1. Connect to the Type-C connector's VBUS pin.
39	VBUS_IN_1		Input of feedback voltage of EA of port 1. Connect to the VBUS node between the output current sense resistor and the VBUS provider NFET.
40	CSNO_1		Negative input of output CSA of port 1. Connect to negative terminal of the output current sense resistor.
41	CSPO_1		Positive input of output CSA of port 1. Connect to positive terminal of the output current sense resistor.
42	COMP_1		EA output pin of port 1. Connect a compensation network to GND. Contact Infineon for assistance in designing the compensation network.
43	BST2_1		Boosted power supply of port 1 boost high-side gate driver. Connect Schottky diode from VDD to BST2_1. Bootstrap capacitor node. Also, connect a bootstrap capacitor from this pin to SW2_1.
44	HG2_1		Boost high-side gate driver output of port 1. Connect to the boost (output) side sync (high-side) FET gate. Use a wide trace to minimize inductance of this connection.

Pin information

Table 2 EZ-PD™ CCG7DC pinout table (continued)

Pin#	Pin name	GPIO port	Description	
45	SW2_1	-	Negative power rail of port 1 boost high-side gate driver. This is also connected to one input terminal of reverse current protection of boost high-side gate driver. Connect to the switch node (inductor) on the boost (output) side. Use a short and wide trace to minimize the inductance and resistance of this connection.	
46	VOUT_1		Output of the buck-boost converter of port 1. This is also connected to one input terminal of reverse current protection of boost high-side gate driver. Connect to the boost sync (high-side) FET's drain. Use a dedicated (Kelvin) trace for this connection.	
47	LG2_1		Boost low-side gate driver output of port 1. Connect to the boost (output) side control (low-side) FET gate. Use a wide trace to minimize inductance of this connection.	
48	PVDD_1		Supply of low-side gate driver of port 1. Connect to VDDD. Use a 1 μ F and 0.1 μ F bypass capacitors as close to the CCG7DC device as possible.	
49	PGND_1		Ground of low-side gate driver of port 1. This is also connected to one input terminal of zero current detection of buck low-side gate driver. Connect directly to Port 0's board ground plane.	
50	LG1_1		Buck low-side gate driver output of port 1. Connect to the buck (input) side sync (low-side) FET gate. Use a wide trace to minimize inductance of this connection.	
51	SW1_1		Negative power rail of port 1 buck high-side gate driver. This is also connected to one input terminal of zero current detection of buck low-side gate driver. Connect to the switch node (inductor) on the buck (input) side. Use a short and wide trace to minimize the inductance and resistance of this connection.	
52	HG1_1		Buck high-side gate driver output of port 1. Connect to the buck (input) side control (high-side) FET gate. Use a wide trace to minimize inductance of this connection.	
53	BST1_1		Boosted power supply of port 1 buck high-side gate driver. Connect Schottky diode from VDDD to BST1_1. Bootstrap capacitor node.	
54	CSNI_1		Negative input of input CSA of port 1. Connect to the negative terminal of the input current sense resistor. Use a dedicated (Kelvin) connection.	
55	CSPI_1		Positive input of input CSA of port 1. Connect to the positive terminal of the input current sense resistor. Use a dedicated (Kelvin) connection.	
56	GPIO14/SWD_DATA		P3.0	GPIO/SWD programming and debug data signal
57	GPIO15/SWD_CLOCK		P3.1	GPIO/SWD programming and debug clock signal
58	GPIO16		P3.2	GPIO
59	GPIO17		P3.3	
60	GPIO18	P3.4		

Pin information

Table 2 EZ-PD™ CCG7DC pinout table (continued)

Pin#	Pin name	GPIO port	Description
61	VIN	-	4 V–24 V input supply. Connect a ceramic bypass capacitor to GND close to this pin.
62	VCCD		1.8-V core LDO output. Connect a 0.1-μF bypass capacitor to ground. Do not connect anything else to this pin.
63	VDDD		5-V LDO output. Connect to pin 25. Also connect a 10-μF bypass capacitor to this pin.
64	GND		Chip ground. Connect to the EPAD and to pin 34.
65	CSPI_0		Positive input of input CSA of port 0. Connect to the positive terminal of the input current sense resistor. Use a dedicated (Kelvin) connection.
66	CSNI_0	-	Negative input of input CSA of port 0. Connect to the negative terminal of the input current sense resistor. Use a dedicated (Kelvin) connection.
67	BST1_0		Boosted power supply of port 0 buck high-side gate driver. Bootstrap capacitor node. Connect Schottky diode from VDDD to BST1_0. Also, connect a bootstrap capacitor from this pin to SW1_0.
68	HG1_0		Buck high-side gate driver output of port 0. Connect to the buck (input) side control (high-side) FET gate. Use a wide trace to minimize inductance of this connection.
	EPAD		Exposed ground pad. Connect directly to pins 34 and 64.

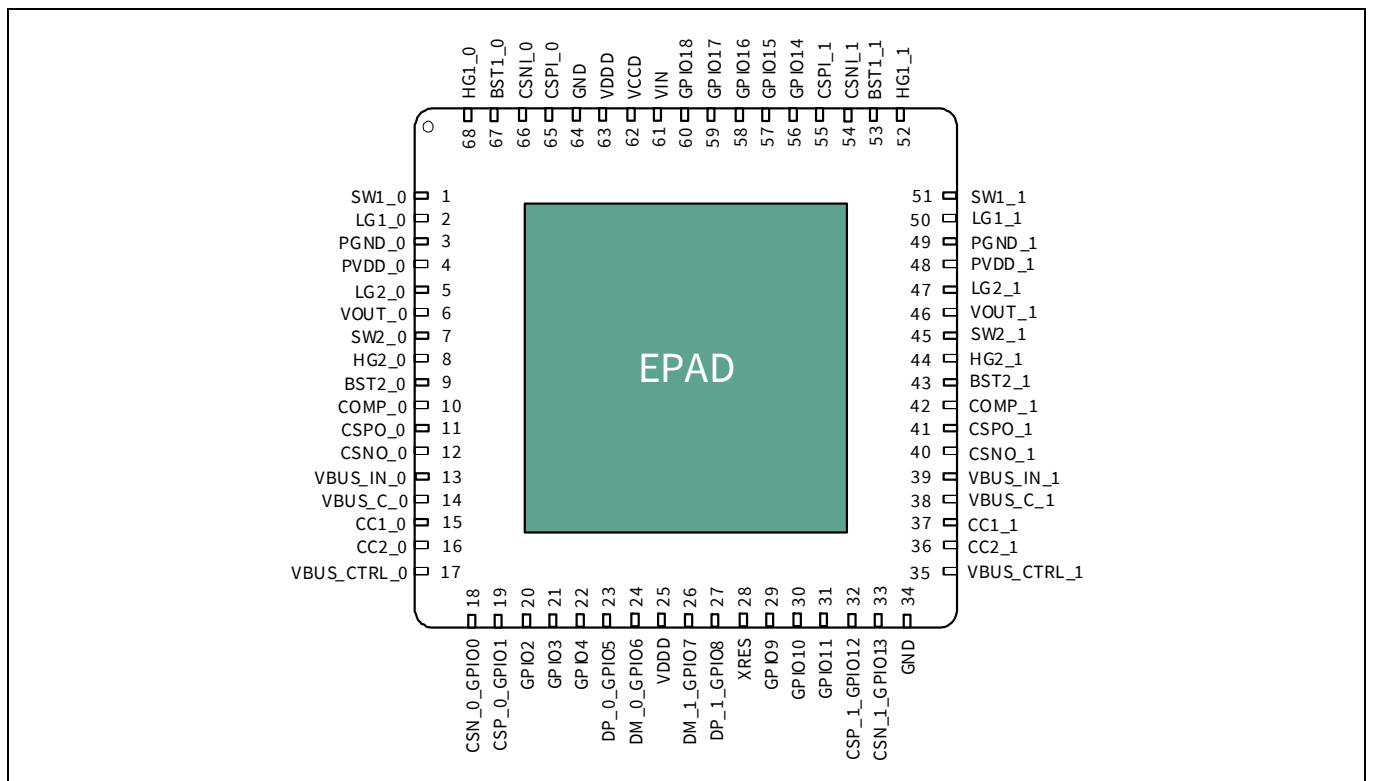

Figure 8 CCG7DC 68-QFN pinout

EZ-PD™ CCG7DC programming and bootloading

4 EZ-PD™ CCG7DC programming and bootloading

There are two ways to program application firmware into a CCG7DC device:

1. Programming the device flash over SWD interface
2. Application firmware update over specific interfaces (CC, I2C)

Generally, the CCG7DC devices are programmed over SWD interface only during development or during the manufacturing process of the end-product. Once the end-product is manufactured, the CCG7DC device's application firmware can be updated via the appropriate bootloader interface. Infineon strongly recommends customers to use the **EZ-PD™ Configuration Utility** to turn off the application FW Update over CC or I2C interface in the firmware that is updated into CCG7DC's flash before mass production. This prevents unauthorized firmware from being updated over CC interface in the field. If you desire to retain the application firmware update over CC/I2C interfaces feature post-production for on-field firmware updates, contact **Infineon Sales** for further guidelines.

4.1 Programming the device flash over SWD interface

The CCG7DC family of devices can be programmed using the SWD interface. Infineon provides programming kits (**CY8CKIT-002 MiniProg3 Kit**) called MiniProg3 and (**CY8CKIT-005 MiniProg4 Kit**) MiniProg4 which can be used to program the flash as well as debug firmware. The flash is programmed by downloading the information from a hex file. This *hex* file is a binary file generated as an output of building the firmware project in **PSoC Creator Software**. Click [here](#) for more information on how to use the MiniProg3 programmer. Click [here](#) for more information on how to use the MiniProg4 programmer. There are many third-party programmers that support mass programming in a manufacturing environment.

As shown in **Figure 9**, the SWD_DAT and SWD_CLK pins are connected to the host programmer's SWDIO (data) and SWDCLK (clock) pins respectively. During SWD programming, the device can be powered by the host programmer by connecting its VTARG (power supply to the target device) to VDDD pins of CCG7DC device. If the CCG7DC device is powered using an on-board power supply, it can be programmed using the "reset programming" option. More details will be provided in the CCG7XXX programming specifications once it is available.

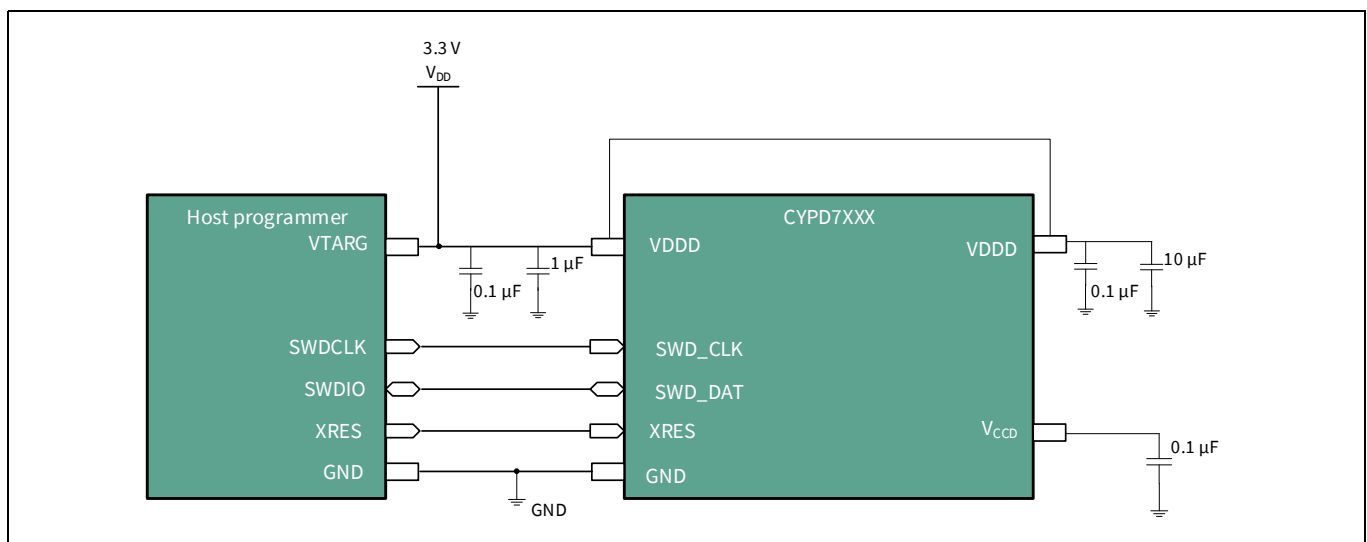

Figure 9 Connecting the programmer to CYPD7XXX device

5 Applications

Figure 10 illustrates a multi-port cigarette lighter adapter (CLA) application block diagram using EZ-PD™ CCG7DC. CLA is powered by the car battery and is used for charging the mobile/tablet/notebook. In this application, CCG7DC will always be in DFP role supporting the charging of the device. It negotiates the power with the connected device and uses the integrated buck-boost controller to supply the required voltage and current.

The DP/DM lines of the Type-C receptacles are connected to CCG7DC to support legacy charging protocols such as QC3.0, Samsung AFC, Apple 2.4A charging, BC v1.2, and so on. When no load is connected to the USB Type-C port, CCG7DC remains in Standby mode without switching on the buck-boost controller.

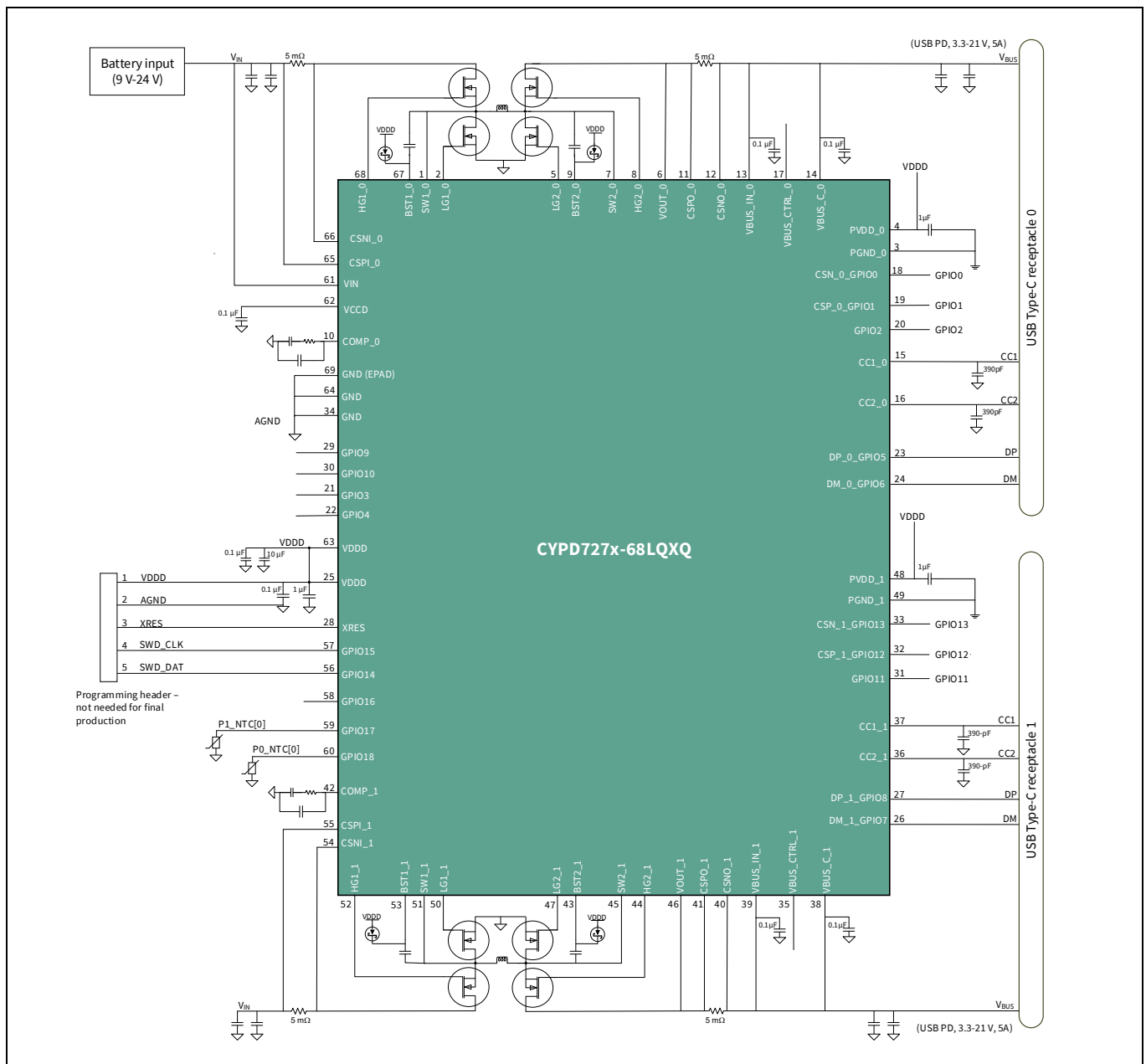

Figure 10 EZ-PD™ CCG7DC CLA application diagram

Table 3 CLA GPIO pin mapping for application diagram in [Figure 10](#)

Pin #	Pin name	Function	GPIO	CLA
18	GPIO0	General purpose IO, available for system level function	P0.0	GPIO
19	GPIO1		P0.1	
20	GPIO2		P0.2	
21	GPIO3		P0.3	
22	GPIO4		P0.4	
23	DP_0_GPIO5	Port 0: USB DP of Type-C port. Supports BC 1.2, QC, Apple Charging and AFC.	P1.0	P0_DP
24	DM_0_GPIO6		P1.1	P0_DM
26	DM_1_GPIO7	Port 1: USB DM of Type-C port. Supports BC 1.2, QC, Apple Charging and AFC.	P1.2	P1_DM
27	DP_1_GPIO8		P1.3	P1_DP
29	GPIO9	General purpose IO, available for system level function	P2.0	GPIO
30	GPIO10		P2.1	
31	GPIO11		P1.4	
32	GPIO12		P1.5	
33	GPIO13		P1.6	
56	GPIO14	Connect to the host programmer's SWDIO (data) for programming the CCG7DC device	P3.0	
57	GPIO15	Connect to the host programmer's SWDCLK (clock) for programming the CCG7DC chip enable pin	P3.1	CHIP_EN
58	GPIO16	GPIO, available for system level function	P3.2	GPIO
59	GPIO17	Port 1: Thermistor	P3.3	P1_NTC[0]
60	GPIO18	Port 0: Thermistor	P3.4	P0_NTC[0]

Figure 11 illustrates a two Type-C port AC/DC power adapter application block diagram using CCG7DC. In this application, CCG7DC will always be in DFP role supporting the charging of the device. It negotiates the power with the connected device and uses the integrated buck controller to supply the required voltage and current. The efficiency can be optimized by dynamically controlling the opto-coupler feedback and thereby regulate the buck input voltage to the closest output voltage. This application can be configured to support the legacy charging protocols - BC1.2 DCP, Qualcomm QC2.0/3.0, Apple Charging, and Samsung AFC.

Applications

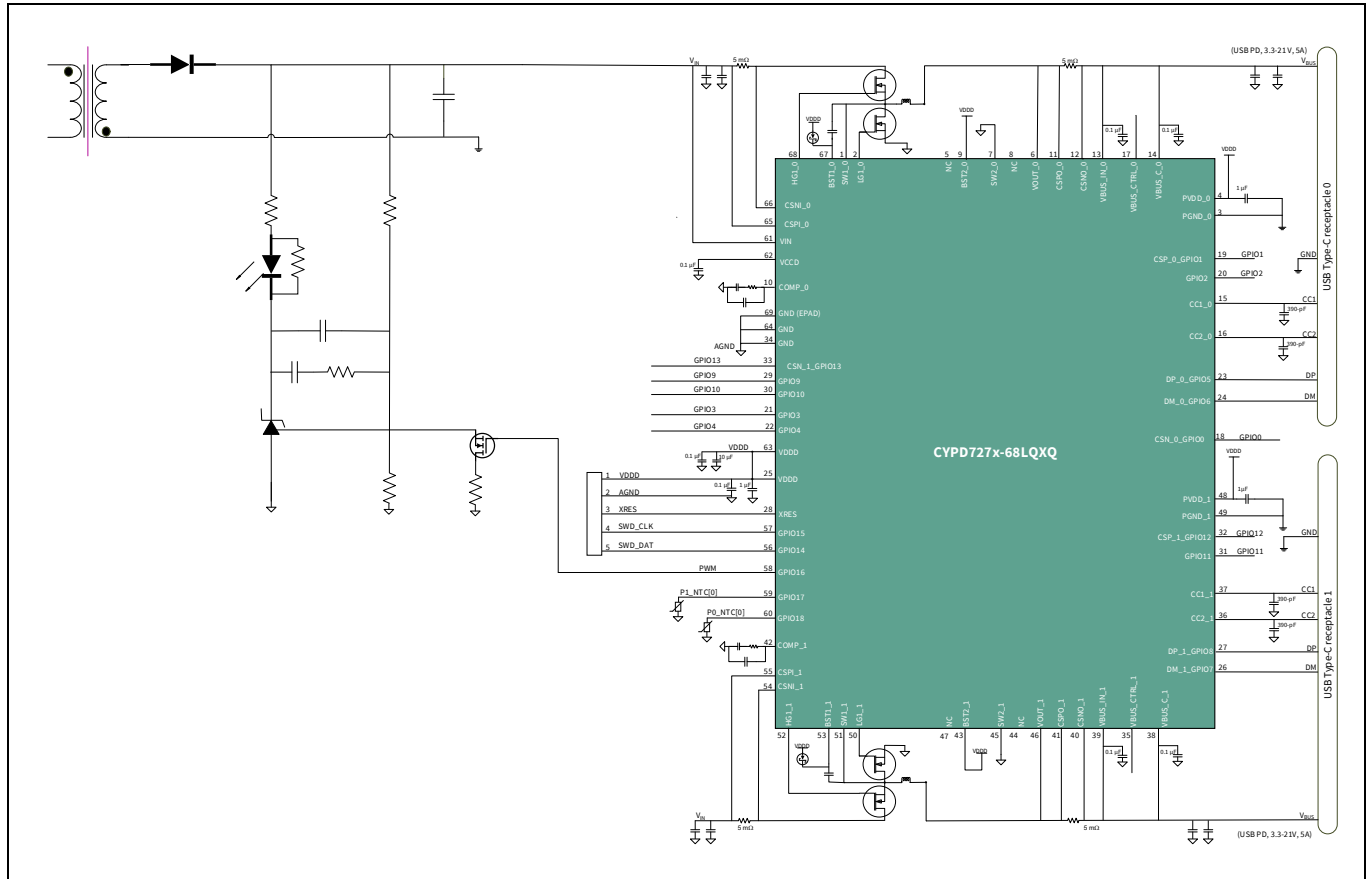

Figure 11 EZ-PD™ CCG7DC multi-port AC-DC adapter application diagram

Table 4 Multi-port AC-DC adapter GPIO pin mapping for application diagram in Figure 11

Pin #	Pin Name	Function	GPIO	AC-DC
18	GPIO0	General purpose IO, available for system level function	P0.0	GPIO
19	GPIO1		P0.1	
20	GPIO2		P0.2	
21	GPIO3		P0.3	
22	GPIO4		P0.4	
23	DP_0_GPIO5	Port 0: USB DP of Type-C port. Supports BC 1.2, QC, Apple Charging and AFC.	P1.0	P0_DP
24	DM_0_GPIO6	Port 0: USB DM of Type-C port. Supports BC 1.2, QC, Apple Charging and AFC.	P1.1	P0_DM
26	DM_1_GPIO7	Port 1: USB DM of Type-C port. Supports BC 1.2, QC, Apple Charging and AFC.	P1.2	P1_DM
27	DP_1_GPIO8	Port 1: USB DP of Type-C port. Supports BC 1.2, QC, Apple Charging and AFC.	P1.3	P1_DP

Applications

Table 4 Multi-port AC-DC adapter GPIO pin mapping for application diagram in **Figure 11** (continued)

Pin #	Pin Name	Function	GPIO	AC-DC
29	GPIO9	General purpose IO, available for system level function	P2.0	GPIO
30	GPIO10		P2.1	
31	GPIO11		P1.4	
32	GPIO12		P1.5	
33	GPIO13		P1.6	
56	GPIO14	Connect to the host programmer's SWDIO (data) for programming the EZ-PD™ CCG7DC device	P3.0	
57	GPIO15	Connect to the host programmer's SWCLK (clock) for programming the EZ-PD™ CCG7DC chip enable pin	P3.1	CHIP_EN
58	GPIO16	PWM output to dynamically control the opto-coupler feedback	P3.2	GPIO
59	GPIO17	Port 1: Thermistor	P3.3	P1_NTC[0]
60	GPIO18	Port 0: Thermistor	P3.4	P0_NTC[0]

6 Electrical specifications

6.1 Absolute maximum ratings

Exceeding maximum ratings may shorten the useful life of the device. User guidelines are not tested.

Table 5 Absolute maximum ratings^[1]

Parameter	Description	Min	Typ	Max	Unit	Description		
VIN_MAJ	Maximum input supply voltage			40	V	-		
VDDD_MAJ	Maximum supply voltage relative to VSS			6				
V5V_MAJ	Maximum supply voltage relative to VSS	-						
VBUS_C_MAJ	Max v_{BUS_C} (P0/P1) voltage relative to Vss			24				
VCC_PIN_ABS	Max voltage on CC1 and CC2 pins			VDDD + 0.5				
VGPIO_ABS	Inputs to GPIO	-0.5		6	mA	Absolute max, current injected per pin		
VGPIO_OVT_ABS	OVT GPIO Voltage	-0.5	-	25				
IGPIO_ABS	Maximum current per GPIO	-25		0.5				
IGPIO_INJECTION	GPIO injection current, max for $V_{IH} > V_{DDD}$, and Min for $V_{IL} < V_{SS}$	-0.5						
ESD_HBM	Electrostatic discharge human body model (ESD HBM)	2000					V	All pins
ESD_CDM	Electrostatic discharge charged device model (ESD CDM)	500						
LU	Pin current for latch-up	-100		100			mA	-
TJ	Junction temperature	-40		125	°C	-		

Note

- Usage above the absolute maximum conditions listed in [Table 5](#) may cause permanent damage to the device. Exposure to absolute maximum conditions for extended periods of time may affect device reliability. The maximum storage temperature is 150°C in compliance with JEDEC Standard JESD22-A103, High Temperature Storage Life. When used below absolute maximum conditions but above normal operating conditions, the device may not operate to specification.

Electrical specifications

Table 6 Pin based absolute maximum ratings

Pin#	Pin name	Absolute minimum (V)	Absolute maximum (V)
1	SW1_0	-0.7	35
2	LG1_0 ^[2]	-0.5	PVDD+0.5
3	PGND_0	-0.3	0.3
4	PVDD_0		VDDD
5	LG2_0 ^[2]	-0.5	PVDD+0.5
6	VOUT_0	-0.3	24
7	SW2_0		24
8	HG2_0 (wrt SW2_0) ^[2]	-0.5	PVDD+0.5
9	BST2_0 (wrt SW2_0) ^[2]		
10	COMP_0 ^[2]	-0.5	
11	CSPO_0	-0.3	24
12	CSNO_0		
13	VBUS_IN_0		
14	VBUS_C_0		
15	CC1_0	-0.5	
16	CC2_0		
17	VBUS_CTRL_0		32
18	CSN_0_GPIO0 ^[2]		PVDD+0.5
19	CSP_0_GPIO1 ^[2]		
20	GPIO2 ^[2]		
21	GPIO3 ^[2]		
22	GPIO4 ^[2]		
23	DP_0_GPIO5 ^[2]		
24	DM_0_GPIO6 ^[2]		
25	VDDD	-	6
26	DM_1_GPIO7 ^[2]	-0.5	PVDD+0.5
27	DP_1_GPIO8 ^[2]		
28	XRES ^[2]		
29	GPIO9 ^[2]		
30	GPIO10 ^[2]		
31	GPIO11 ^[2]		
32	CSP_1_GPIO12 ^[2]		
33	CSN_1_GPIO13 ^[2]		
34	GND	-	-

Notes

2. Max voltage cannot exceed 6 V
3. Max absolute voltage wrt GND must not exceed 40 V

Electrical specifications

Table 6 Pin based absolute maximum ratings (continued)

Pin#	Pin name	Absolute minimum (V)	Absolute maximum (V)
35	VBUS_CTRL_1	-0.5	32
36	CC2_1		24
37	CC1_1		
38	VBUS_C_1	-0.3	
39	VBUS_IN_1		
40	CSNO_1		
41	CSPO_1		
42	COMP_1 ^[2]	-0.5	PVDD+0.5
43	BST2_1 ^[2] (wrt SW2_1)		
44	HG2_1 ^[2] (wrt SW2_1)	-0.5	
45	SW2_1	-0.3	24
46	VOUT_1	-0.3	24
47	LG2_1 ^[2]	-0.5	PVDD+0.5
48	PVDD_1		VDDD
49	PGND_1	-0.3	0.3
50	LG1_1 ^[2]	-0.5	PVDD+0.5
51	SW1_1	-0.7	35
52	HG1_1 ^[2,3] (wrt SW1_1)	-0.5	PVDD+0.5
53	BST1_1 ^[2,3] (wrt SW1_1)		
54	CSNI_1	-0.3	40
55	CSPI_1		40
56	GPIO14/SWD_DAT ^[2]	-0.5	PVDD+0.5
57	GPIO15/SWD_CLK ^[2]		
58	GPIO16 ^[2]		
59	GPIO17 ^[2]		
60	GPIO18 ^[2]		
61	VIN	-0.3	40
62	VCCD	-	-
63	VDDD		6
64	GND		-
65	CSPI_0	-0.3	40
66	CSNI_0		
67	BST1_0 ^[2,3] (wrt SW1_0)	-	PVDD+0.5
68	HG1_0 ^[2,3] (wrt SW1_0)	-0.5	
	EPAD	-	-

Notes

2. Max voltage cannot exceed 6 V
3. Max absolute voltage wrt GND must not exceed 40 V

Electrical specifications

6.2 Device-level specifications

All specifications are valid for $-40\text{ °C} \leq T_A \leq 105\text{ °C}$ and $T_J \leq 125\text{ °C}$, except where noted. Specifications are valid for 3.0 V to 5.5 V except where noted.

6.2.1 DC specifications

Table 7 DC specifications (operating conditions)

Spec ID	Parameter	Description	Min	Typ	Max	Unit	Details/conditions
SID.PWR#1	VIN	Input supply voltage	4.0		24	V	-
SID.PWR#1A	VIN_BB	Buck Boost Operating input supply voltage	5.5		24		
SID.PWR#2	VDDD_REG	VDDD output with VIN 5.5 V to 24 V, Max load = 150 mA	4.6		5.5		
SID.PWR#3	VDDD_MIN	VDDD output with VIN 4 V to 5.5 V, Max load = 20mA	$V_{IN} - 0.2$		-		
SID.PWR#20	VBUS	VBUS_C_0/1 valid range	3.3		21.5		
SID.PWR#5	VCCD	Regulated output voltage (for Core Logic)	-	1.8	-		
SID.PWR#16	CEFC_VCCD	External regulator voltage bypass for VCCD	80	100	120	nF	X5R ceramic
SID.PWR#17	CEXC_VDDD	Power Supply decoupling capacitor for VDDD		10		μ F	
SID.PWR#18	CEXV	Bootstrap supply capacitor (BST1_0, BST1_1, BST2_0, BST2_1)		0.1			
SID.PWR#24	IDD_ACT	Supply current at 0.4 MHz switching frequency	-	85	-	mA	TA = 25°C, VIN = 12 V. CC IO in transmit or receive, no I/O sourcing current, no VCONN load current, CPU at 24 MHz, two PD ports active. Buck-boost converter ON, 3-nF gate driver capacitance.

Deepsleep mode

SID_DS1	IDD_DS1	VIN = 12 V. CC wakeup on, Type-C not connected	-	110	-	μ A	Type-C not attached, CC enabled for wakeup. Rp connection should be enabled for both PD ports. TA = 25 °C. All faults disabled.
SID_DS2	IDD_DS2	VIN = 12 V		50			USB-PD disabled. Wake-up from GPIO. TA = 25 °C.

Electrical specifications

Table 7 DC specifications (operating conditions) (continued)

Spec ID	Parameter	Description	Min	Typ	Max	Unit	Details/conditions
SID_DS3	IDD_DS3	$V_{IN} = 12$ V. CC wakeup on, Type-C not connected	-	450	-	μ A	Type-C not attached, CC enabled for wakeup. Rp connection should be enabled for both PD ports. $T_A = 25$ °C. All faults disabled except VBAT-GND.

6.2.2 CPU**Table 8 CPU specifications**

Spec ID	Parameter	Description	Min	Typ	Max	Unit	Details/conditions
SID.CLK#4	F_{CPU}	CPU input frequency	-	-	48	MHz	-40 °C $\leq T_A \leq +105$ °C, All V_{DDD}
SID.PWR#19	$T_{DEEPSLEEP}$	Wakeup from deepsleep mode	-	35	-	μ s	-
SYS.XRES#5	T_{XRES}	External reset pulse width	5	-	-	-	-
SYS.FES#1	T_{PWR_RDY}	Power-up to “ready to accept I ² C/CC command”	-	5	25	ms	-

6.2.3 GPIO**Table 9 GPIO DC specifications**

Spec ID	Parameter	Description	Min	Typ	Max	Unit	Details/conditions	
SID.GIO#9	V_{IH_CMOS}	Input voltage HIGH threshold	$0.7 \times V_{DDD}$	-	-	V	CMOS input	
SID.GIO#10	V_{IL_CMOS}	Input voltage LOW threshold	-	-	$0.3 \times V_{DDD}$			
SID.GIO#7	V_{OH_3V}	Output voltage HIGH level	$V_{DDD} - 0.6$	-	-			$I_{OH} = -4$ mA, -40 °C $\leq T_A \leq +105$ °C
SID.GIO#8	V_{OL_3V}	Output voltage LOW level	-	-	0.6			$I_{OL} = 10$ mA, -40 °C $\leq T_A \leq +105$ °C
SID.GIO#2	Rpu	Pull-up resistor when enabled	3.5	5.6	8.5	k Ω	-40 °C $\leq T_A \leq +105$ °C	
SID.GIO#3	Rpd	Pull-down resistor when enabled						
SID.GIO#4	I_{IL}	Input leakage current (absolute value)	-	-	2	nA	+25 °C T_A , 3- V_{DDD}	
SID.GIO#5	C_{PIN_A}	Max pin capacitance	-	-	22	pF	-40 °C $\leq T_A \leq +105$ °C, Capacitance on DP, DM pins	
SID.GIO#6	C_{PIN}				3		7	-40 °C $\leq T_A \leq +105$ °C, ALL V_{DDD} , All other I/Os
SID.GIO#11	V_{IH_TTL}	LVTTTL input	2.0	-	-	V	-40 °C to +105 °C T_A	
SID.GIO#12	V_{IL_TTL}		-		0.8			

Electrical specifications

Table 9 GPIO DC specifications (continued)

Spec ID	Parameter	Description	Min	Typ	Max	Unit	Details/conditions
SID.GIO#13	V_{HYSTTL}	Input hysteresis, LVTTTL, $V_{DDD} > 2.7 V$	100	-	-	mV	$V_{DDD} > 2.7 V$
SID.GIO#14	$V_{HYSCMOS}$	Input hysteresis CMOS	$0.1 \times V_{DDD}$				-

Table 10 GPIO AC specifications

Spec ID	Parameter	Description	Min	Typ	Max	Unit	Details/conditions
SID.GIO#16	T_{RISEF}	Rise time in fast strong mode	2	-	12	ns	$C_{load} = 25 pF,$ $-40^{\circ}C \leq T_A \leq +105^{\circ}C$
SID.GIO#17	T_{FALLF}	Fall time in fast strong mode			60		
SID.GIO#18	T_{RISES}	Rise time in slow strong mode	10		16	MHz	
SID.GIO#19	T_{FALLS}	Fall time in slow strong mode					
SID.GIO#20	F_{GPIO_OUT1}	GPIO F_{OUT} ; $3.0 V \leq V_{DDD} \leq 5.5 V$, fast strong mode	-	-	16	-	$-40^{\circ}C \leq T_A \leq +105^{\circ}C$
SID.GIO#21	F_{GPIO_OUT2}	GPIO F_{OUT} ; $3.0 V \leq V_{DDD} \leq 5.5 V$, slow strong mode.			7		
SID.GIO#22	F_{GPIO_IN}	GPIO input operating frequency; $3.0 V \leq V_{DDD} \leq 5.5 V$.	-	-	16	-	$-40^{\circ}C \leq T_A \leq +105^{\circ}C$

Electrical specifications

Table 11 GPIO OVT DC specifications

Spec ID	Parameter	Description	Min	Typ	Max	Unit	Details/ conditions
SID.GPIO_20VT_GIO#4	GPIO_20VT_I_LU	GPIO_20VT latch up current limits	-140		140	mA	Max / Min current in to any input or output, pin-to-pin, pin-to-supply
SID.GPIO_20VT_GIO#5	GPIO_20VT_RPU	GPIO_20VT Pull-up resistor value	3.5		8.5	kΩ	-40 °C ≤ T _A ≤ +105 °C, All V _{DDD}
SID.GPIO_20VT_GIO#6	GPIO_20VT_RPD	GPIO_20VT Pull-down resistor value					
SID.GPIO_20VT_GIO#16	GPIO_20VT_IIL	GPIO_20VT Input leakage current (absolute value)	-	-	2	nA	+25 °C T _A , 3-V V _{DDD}
SID.GPIO_20VT_GIO#17	GPIO_20VT_CPIN	GPIO_20VT pin capacitance					
SID.GPIO_20VT_GIO#33	GPIO_20VT_Voh	GPIO_20VT Output voltage high level.	VDDD - 0.6		-	V	I _{OH} = -4 mA
SID.GPIO_20VT_GIO#36	GPIO_20VT_Vol	GPIO_20VT Output Voltage low level.	-		0.6		I _{OL} = 8 mA
SID.GPIO_20VT_GIO#41	GPIO_20VT_Vih_LVTTL	GPIO_20VT LVTTL input	2		-		-40 °C ≤ T _A ≤ +105 °C, All V _{DDD}
SID.GPIO_20VT_GIO#42	GPIO_20VT_Vil_LVTTL	GPIO_20VT LVTTL input	-		0.8		
SID.GPIO_20VT_GIO#43	GPIO_20VT_Vhyst _{tl}	GPIO_20VT Input hysteresis LVTTL	100		-	mV	-40 °C ≤ T _A ≤ +105 °C, All V _{DDD}
SID.GPIO_20VT_GIO#45	GPIO_20VT_ITOT_GIO	GPIO_20VT Maximum total sink pin current to ground	-		95	mA	V (GPIO_20VT pin) > V _{DDD}

Electrical specifications

Table 12 GPIO OVT AC specifications

Spec ID	Parameter	Description	Min	Typ	Max	Unit	Details/ conditions
SID.GPIO_20VT_70	GPIO_20VT_TriseF	GPIO_20VT rise time in fast strong mode	1		15	ns	All V_{DD} , $C_{load} = 25$ pF
SID.GPIO_20VT_71	GPIO_20VT_TfallF	GPIO_20VT fall time in fast strong mode					
SID.GPIO_20VT_GIO#46	GPIO_20VT_TriseS	GPIO_20VT rise time in slow strong mode	10		70		
SID.GPIO_20VT_GIO#47	GPIO_20VT_TfallS	GPIO_20VT fall time in slow strong mode					
SID.GPIO_20VT_GIO#48	GPIO_20VT_FGPIO_OUT1	GPIO_20VT GPIO Fout; $3\text{ V} \leq V_{DD} \leq 5.5\text{ V}$. Fast strong mode.	-		33	MHz	
SID.GPIO_20VT_GIO#50	GPIO_20VT_FGPIO_OUT3	GPIO_20VT GPIO Fout; $3\text{ V} \leq V_{DD} \leq 5.5\text{ V}$. Slow strong mode.					
SID.GPIO_20VT_GIO#52	GPIO_20VT_FGPIO_IN	GPIO_20VT GPIO input operating frequency; $3\text{ V} \leq V_{DD} \leq 5.5\text{ V}$					
					8		All V_{DD}

6.2.4 XRES**Table 13 XRES DC specifications**

Spec ID	Parameter	Description	Min	Typ	Max	Unit	Details/ conditions
SID.XRES#1	V_{IH_XRES}	Input voltage HIGH threshold on XRES pin	$0.7 \times V_{DD}$	-	-	V	CMOS input
SID.XRES#2	V_{IL_XRES}	Input voltage LOW threshold on XRES pin	-		$0.3 \times V_{DD}$		
SID.XRES#3	C_{IN_XRES}	Input capacitance on XRES pin		-		7	pF
SID.XRES#4	$V_{HYSXRES}$	Input voltage hysteresis on XRES pin	$0.05 \times V_{DD}$			-	mV

Electrical specifications

6.3 Digital peripherals

The following specifications apply to the Timer/Counter/PWM peripherals in the Timer mode.

6.3.1 Pulse-width modulation (PWM) for GPIO pins

Table 14 PWM AC specifications

Spec ID	Parameter	Description	Min	Typ	Max	Unit	Details/conditions
SID.TCPWM.1	TCPWM _{FREQ}	Operating frequency	-		F _c	MHz	F _c max = CLK_SYS
SID.TCPWM.3	T _{PWMEXT}	Output trigger pulse width	2/F _c	-	-	ns	Minimum possible width of overflow, underflow, and CC (counter equals compare value) outputs
SID.TCPWM.4	T _{CRES}	Resolution of counter	1/F _c				Minimum time between successive counts
SID.TCPWM.5	PWM _{RES}	PWM resolution					Minimum pulse width of PWM output

6.3.2 I²C

Table 15 Fixed I²C AC specifications

Spec ID	Parameter	Description	Min	Typ	Max	Unit	Details/conditions
SID153	F _{I2C1}	Bit rate	-	-	1	Mbps	-

6.3.3 UART

Table 16 Fixed UART AC specifications

Spec ID	Parameter	Description	Min	Typ	Max	Unit	Details/conditions
SID162	F _{UART}	Bit rate	-	-	1	Mbps	-

6.3.4 SPI

Table 17 Fixed SPI AC specifications

Spec ID	Parameter	Description	Min	Typ	Max	Unit	Details/conditions
SID166	F _{SPI}	SPI operating frequency (Master; 6X oversampling)	-	-	8	MHz	-

Table 18 Fixed SPI slave mode AC specifications

Spec ID	Parameter	Description	Min	Typ	Max	Unit	Details/conditions
SID170	T _{DMI}	MOSI valid before Sclock capturing edge	40		-		-
SID171	T _{DSO}	MISO valid after Sclock driving edge			48 + (3 × T _{CPU})		T _{CPU} = 1/F _{CPU}
SID171A	T _{DSO_EXT}	MISO valid after Sclock driving edge in Ext Clk mode	-	-	48	ns	
SID172	T _{HSD}	Previous MISO data hold time	0				-
SID172A	T _{SSELCK}	SSEL valid to first SCK valid edge	100		-		

Electrical specifications

Table 19 Fixed SPI master mode AC specifications

Spec ID	Parameter	Description	Min	Typ	Max	Unit	Details/conditions
SID167	T _{DMO}	MOSI valid after SClk driving edge	-	-	15	ns	-
SID168	T _{DSI}	MISO valid before SClk capturing edge	20	-	-		Full clock, late MISO sampling
SID169	T _{HMO}	Previous MOSI data hold time	0	-	-		Referred to slave capturing edge

6.3.5 Memory**Table 20 Flash AC specifications**

Spec ID	Parameter	Description	Min	Typ	Max	Unit	Details/conditions
SID.MEM#2	FLASH_WRITE	Row (block) write time (erase and program)	-	-	20	ms	-40 °C ≤ T _A ≤ +85 °C, All V _{DDD}
SID.MEM#1	FLASH_ERASE	Row erase time			15.5		
SID.MEM#5	FLASH_ROW_PGM	Row program time after erase			7		
SID178	T _{BULKERASE}	Bulk erase time (32 KB)			35		
SID180	T _{DEVPROG}	Total device program time			7.5	s	
SID.MEM#6	FLASH_ENPB	Flash write endurance	100k	-	-	cycles	25 °C ≤ T _A ≤ 55 °C, All V _{DDD}
SID182	F _{RET1}	Flash retention, T _A ≤ 55 °C, 100K P/E cycles	20	-	-	years	-
SID182A	F _{RET2}	Flash retention, T _A ≤ 85 °C, 10K P/E cycles	10				

Electrical specifications

6.4 System resources

6.4.1 Power-on-reset (POR) with brown-out

Table 21 Imprecise power-on reset (IPOR)

Spec ID	Parameter	Description	Min	Typ	Max	Unit	Details/conditions
SID185	V _{RISEIPOR}	POR Rising trip voltage	0.80	-	1.50	V	-40 °C ≤ T _A ≤ +105 °C, All V _{DDD} .
SID186	V _{FALLIPOR}	POR Falling trip voltage	0.70		1.4		

Table 22 Precise POR

Spec ID	Parameter	Description	Min	Typ	Max	Unit	Details/conditions
SID190	V _{FALLPPOR}	Brown-out detect (BOD) trip voltage in Active/Sleep modes	1.48	-	1.62	V	-40 °C ≤ T _A ≤ +105 °C, All V _{DDD} .
SID192	V _{FALLDPSLP}	BOD trip voltage in deepsleep mode	1.1		1.5		

6.4.2 SWD interface

Table 23 SWD interface specifications

Spec ID	Parameter	Description	Min	Typ	Max	Unit	Details/conditions
SID.SWD#1	F_SWDCLK1	3.0 V ≤ V _{DDIO} ≤ 5.5 V	-	-	14	MHz	-
SID.SWD#2	T_SWDI_SETUP	T = 1/f SWDCLK	0.25 × T		-	ns	
SID.SWD#3	T_SWDI_HOLD				-		
SID.SWD#4	T_SWDO_VALID				-		
SID.SWD#5	T_SWDO_HOLD				1		

6.4.3 Internal main oscillator

Table 24 IMO AC specifications

Spec ID	Parameter	Description	Min	Typ	Max	Unit	Details/conditions
SID.CLK#13	F _{IMOTOL}	Frequency variation at 48 MHz (trimmed)	-	-	±2	%	3.0 V ≤ V _{DDD} < 5.5 V. -40 °C ≤ T _A ≤ 105 °C.
SID226	T _{STARTIMO}	IMO start-up time	-		7	µs	-40 °C ≤ T _A ≤ +105 °C, All V _{DDD} .
SID.CLK#1	F _{IMO}	IMO frequency	24		48	MHz	

6.4.4 Internal low-speed oscillator

Table 25 ILO AC specifications

Spec ID	Parameter	Description	Min	Typ	Max	Unit	Details/conditions
SID234	T _{STARTILO1}	ILO start-up time	-	-	2	ms	-40 °C ≤ T _A ≤ +105 °C, All V _{DDD} .
SID238	T _{ILODUTY}	ILO duty cycle	40	50	60	%	
SID.CLK#5	F _{ILO}	ILO frequency	20	40	80	kHz	-

Electrical specifications

6.4.5 PD

Table 26 PD DC specifications

Spec ID	Parameter	Description	Min	Typ	Max	Unit	Details/ conditions
SID.DC.cc_shvt.1	vSwing	Transmitter output high voltage	1.05	-	1.2	V	
SID.DC.cc_shvt.2	vSwing_low	Transmitter output low voltage	-		0.075		
SID.DC.cc_shvt.3	zDriver	Transmitter output impedance	33		75	Ω	
SID.DC.cc_shvt.4	zBmcRx	Receiver input impedance	10		-	MΩ	
SID.DC.cc_shvt.5	Idac_std	Source current for USB standard advertisement	64		96	μA	
SID.DC.cc_shvt.6	Idac_1p5a	Source current for 1.5 A at 5 V advertisement	166		194		
SID.DC.cc_shvt.7	Idac_3a	Source current for 3 A at 5 V advertisement	304		356		
SID.DC.cc_shvt.8	Rd	Pull down termination resistance when acting as UFP (upstream facing port)	4.59		5.61	kΩ	
SID.DC.cc_shvt.10	zOPEN	CC impedance to ground when disabled	108		-		
SID.DC.cc_shvt.11	DFP_default_0p2	CC voltages on DFP side-standard USB	0.15		0.25	V	
SID.DC.cc_shvt.12	DFP_1.5A_0p4	CC voltages on DFP side-1.5 A	0.35		0.45		
SID.DC.cc_shvt.13	DFP_3A_0p8	CC voltages on DFP side-3 A	0.75		0.85		
SID.DC.cc_shvt.14	DFP_3A_2p6	CC voltages on DFP side-3 A	2.45		2.75	V	
SID.DC.cc_shvt.15	UFP_default_0p66	CC voltages on UFP side-standard USB	0.61		0.7		
SID.DC.cc_shvt.16	UFP_1.5A_1p23	CC voltages on UFP side-1.5 A	1.16		1.31		
SID.DC.cc_shvt.17	Vattach_ds	Deepsleep attach threshold	0.3		0.6	%	
SID.DC.cc_shvt.18	Rattach_ds	Deepsleep pull-up resistor	10		50	kΩ	
SID.DC.cc_shvt.19	VTX_step	TX Drive voltage step size	80		120	mV	

Electrical specifications

6.4.6 Analog-to-digital converter

Table 27 ADC DC specifications

Spec ID	Parameter	Description	Min	Typ	Max	Unit	Details/conditions
SID.ADC.1	Resolution	ADC resolution	–	8	–	Bits	–
SID.ADC.2	INL	Integral non-linearity	–1.5	–	1.5	LSB	Reference voltage generated from bandgap
SID.ADC.3	DNL	Differential non-linearity	–2.5		2.5		Reference voltage generated from V_{DD}
SID.ADC.4	Gain Error	Gain error	–1.5		1.5		Reference voltage generated from bandgap
SID.ADC.5	VREF_ADC1	Reference voltage of ADC	V_{DDmin}	2.0	V_{DDmax}	V	Reference voltage generated from V_{DD}
SID.ADC.6	VREF_ADC2	Reference voltage of ADC	1.96		2.04		Reference voltage generated from deepsleep reference

6.4.7 HS CSA

Table 28 HS CSA DC specifications

Spec ID	Parameter	Description	Min	Typ	Max	Unit	Details/conditions
SID.HSCSA.1	Csa_Acc1	CSA accuracy 5 mV < Vsense < 10 mV	–15	–	15	%	Active mode
SID.HSCSA.2	Csa_Acc2	CSA accuracy 10 mV < Vsense < 15 mV	–10		10		
SID.HSCSA.3	Csa_Acc3	CSA accuracy 15 mV < Vsense < 25 mV	–5		5		
SID.HSCSA.4	Csa_Acc4	CSA accuracy 25 mV < Vsense	–3		3		
SID.HSCSA.7	Csa_SCP_Acc1	CSA SCP at 6A with 5-mΩ sense resistor	–10	10			
SID.HSCSA.8	Csa_SCP_Acc2	CSA SCP at 10A with 5-mΩ sense resistor					
SID.HSCSA.9	Csa_OCP_1A	CSA OCP at 1A with 5-mΩ sense resistor	104	130	156		
SID.HSCSA.10	Csa_OCP_5A	CSA OCP for 5A with 5-mΩ sense resistor	123	130	137		

Table 29 HS CSA AC specifications

Spec ID	Parameter	Description	Min	Typ	Max	Unit	Details/conditions
SID.HSCSA.AC.1	T_{SCP_GATE}	Delay from SCP threshold trip to external NFET power gate turn off	–	3.5	–	μs	1-nF NFET gate
SID.HSCSA.AC.2	$T_{SCP_GATE_1}$	Delay from SCP threshold trip to external NFET power gate turn off		8			3-nF NFET gate

Electrical specifications

6.4.8 UV/OV**Table 30 UV/OV specifications**

Spec ID	Parameter	Description	Min	Typ	Max	Unit	Details/conditions
SID.UVOV.1	V _{THOV1}	Overvoltage threshold Accuracy, 4 V to 11 V	-3	-	3	%	Active mode
SID.UVOV.2	V _{THOV2}	Overvoltage threshold Accuracy, 11 V to 21.5 V	-3.2		3.2		
SID.UVOV.3	V _{THUV1}	Undervoltage threshold Accuracy, 3 V to 3.3 V	-4		4		
SID.UVOV.4	V _{THUV2}	Undervoltage threshold Accuracy, 3.3 V to 4.0 V	-3.5		3.5		
SID.UVOV.5	V _{THUV3}	Undervoltage threshold Accuracy, 4.0 V to 21.5 V	-3		3		

6.4.9 VCONN switch**Table 31 VCONN switch DC specifications**

Spec ID	Parameter	Description	Min	Typ	Max	Unit	Details/conditions
DC.VCONN.1	VCONN_OUT	VCONN output voltage with 20 mA load current	4.5	-	5.5	V	-
DC.VCONN.2	I _{LEAK}	Connector side pin leakage current	-		10	μA	
DC.VCONN.3	I _{OCP}	VCONN over-current protection threshold	22.5		30	37.5	

Table 32 VCONN switch AC specifications

Spec ID	Parameter	Description	Min	Typ	Max	Unit	Details/conditions
AC.VCONN.1	T _{ON}	VCONN switch turn-on time	-	-	600	μs	-
AC.VCONN.2	T _{OFF}	VCONN switch turn-off time			10		

6.4.10 V_{BUS}**Table 33 V_{BUS} discharge specifications**

Spec ID	Parameter	Description	Min	Typ	Max	Unit	Details/conditions
SID.VBUS.DISC.1	R1	20-V NMOS ON resistance for DS = 1	500	-	2000	Ω	Measured at 0.5 V
SID.VBUS.DISC.2	R2	20-V NMOS ON resistance for DS = 2	250		1000		
SID.VBUS.DISC.3	R4	20-V NMOS ON resistance for DS = 4	125		500		
SID.VBUS.DISC.4	R8	20-V NMOS ON resistance for DS = 8	62.5		250		
SID.VBUS.DISC.5	R16	20-V NMOS ON resistance for DS = 16	31.25		125		
SID.VBUS.DISC.6	Vbus_stop_ error	Error percentage of final VBUS value from setting	-		10	%	When VBUS is discharged to 5 V

Electrical specifications

6.4.11 Voltage regulation

Table 34 Voltage regulation DC specifications

Spec ID	Parameter	Description	Min	Typ	Max	Unit	Details/conditions
SID.DC.VR.1	VOUT	VBUS_IN output voltage range	3.3	–	21.5	V	–
SID.DC.VR.2	VR	VBUS_IN voltage regulation accuracy	–	±3	±5	%	
SID.DC.VR.3	VIN_UVLO	VIN Supply below which chip will get reset	1.7	–	3.0	V	

Table 35 Voltage regulator specifications

Spec ID	Parameter	Description	Min	Typ	Max	Unit	Details/conditions
SID.VREG.1	T _{START}	Total startup time for the regulator supply outputs	–	–	200	µs	–

6.4.12 VBUS gate driver

Table 36 VBUS gate driver DC specifications

Spec ID	Parameter	Description	Min	Typ	Max	Unit	Details/conditions
SID.GD.1	GD_VGS	Gate to source overdrive during ON condition	4.5	5	10	V	NFET driver is ON
SID.GD.2	GD_RPD	Resistance when pull-down enabled	–	–	2	kΩ	Applicable on VBUS_CTRL to turn off external NFET
SID.GD.5	GD_drv	Programmable typical gate current	0.3		9.75	µA	–

Table 37 VBUS gate driver AC Specifications

Spec ID	Parameter	Description	Min	Typ	Max	Unit	Details/conditions
SID.GD.3	T _{ON}	VBUS_CTRL LOW to HIGH (1V to VBUS + 1 V) with 3-nF external capacitance	2	5	10	ms	V _{BUS_IN} = 5 V
SID.GD.4	T _{OFF}	VBUS_CTRL HIGH to LOW (90% to 10%) with 3-nF external capacitance	–	7	–	µs	V _{BUS_IN} = 21.5 V

6.4.12.1 PWM controller

Table 38 Buck-boost PWM controller specifications

Spec ID	Parameter	Description	Min	Typ	Max	Unit	Details/conditions
PWM.1	F _{SW}	Switching frequency	150	–	600	kHz	–
PWM.2	FSS	Spread spectrum frequency dithering span	–	10	–	%	
PWM.3	Ratio_Buck_BB	Buck to buck boost ratio		1.16		–	
PWM.4	Ratio_Boost_BB	Boost to buck boost ratio		0.84		–	

Electrical specifications

6.4.12.2 Nfet gate driver

Table 39 Buck-boost Nfet gate driver specifications

Spec ID	Parameter	Description	Min	Typ	Max	Unit	Details/conditions		
DR.1	R_HS_PU	Top-side gate driver on-resistance - Gate pull-up	-	2	-	Ω	-		
DR.2	R_HS_PD	Top-side gate driver on-resistance - Gate pull-down		1.5					
DR.3	R_LS_PU	Bottom-side gate driver on-resistance - Gate pull-up		2					
DR.4	R_LS_PD	Bottom-side gate driver on-resistance - Gate pull-down		1.5					
DR.5	Dead_HS	Dead time before high-side rising edge		30		ns		-	-
DR.6	Dead_LS	Dead time before low-side rising edge							
DR.7	Tr_HS	Top-side gate driver rise time							
DR.8	Tf_HS	Top-side gate driver fall time							
DR.9	Tr_LS	Bottom-side gate driver rise time							
DR.10	Tf_LS	Bottom-side gate driver fall time							

6.4.12.3 LS-SCP

Table 40 LS-SCP DC specifications

Spec ID	Parameter	Description	Min	Typ	Max	Unit	Details/conditions
SID.LSSCP.DC.1	SCP_6A	Short circuit current detect @ 6A	5.4	6	6.6	A	Using differential inputs (CSN_1_GPIO12, CSP_1_GPIO13 or CSP_0_GPIO0, CSN_0_GPIO1)
SID.LSSCP.DC.1A	SCP_6A_SE	Short circuit current detect @ 6A	4.5	6	7.5		Using single ended inputs (CSP_1_GPIO13 or CSP_0_GPIO0) and internal ground
SID.LSSCP.DC.2	SCP_10A	Short circuit current detect @10A	9	10	11		Using differential inputs (CSN_1_GPIO12, CSP_1_GPIO13 or CSP_0_GPIO0, CSN_0_GPIO1)
SID.LSSCP.DC.2A	SCP_10A_SE	Short circuit current detect @10A	7.5	10	12.5		Using single ended inputs (CSP_1_GPIO13 or CSP_0_GPIO0) and internal ground

6.4.12.4 Thermal specifications

Table 41 Thermal specifications

Spec ID	Parameter	Description	Min	Typ	Max	Unit	Details/conditions
SID.OTP.1	OTP	Thermal shutdown	120	125	130	°C	-

7 Ordering information

Table 42 lists the EZ-PD™ CCG7DC part numbers and features.

Table 42 EZ-PD™ CCG7DC ordering information

MPN	Application	Termination resistor	Role	Switching frequency	Package type
CYPD7271-68LQXQ	Dual-port USB-C PD AC-DC power adapter/cigarette lighter adapter (CLA)	R _P	DFP (Power source only)	150 kHz - 600 kHz	68-pin QFN

7.1 Ordering code definitions

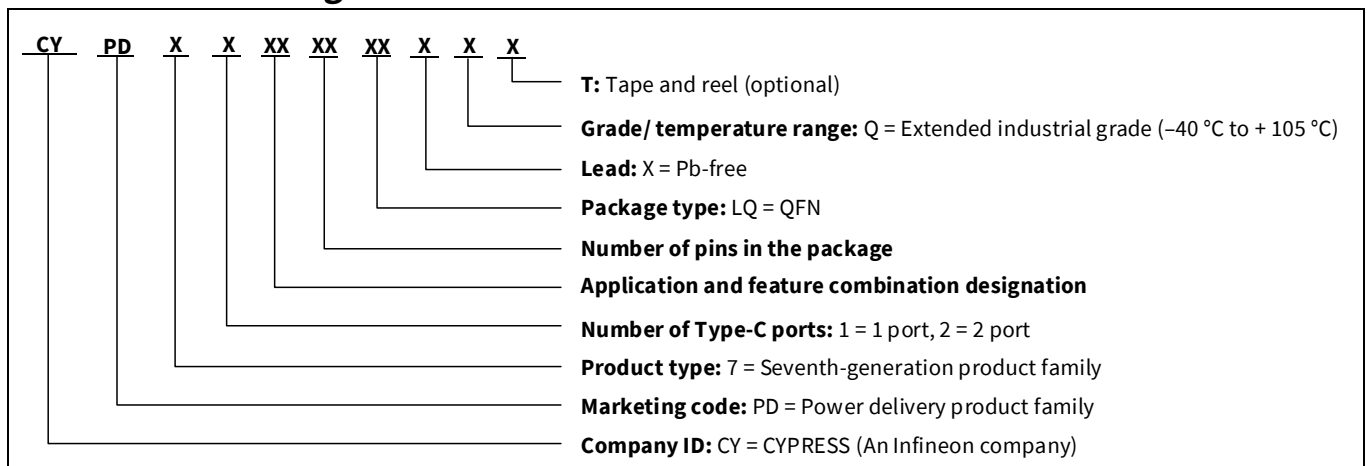

Packaging

8 Packaging

Table 43 Package characteristics

Parameter	Description	Conditions	Min	Typ	Max	Unit
T _J	Operating junction temperature	-	-40	25	125	°C
T _{JA}	Package θ_{JA}		-	-	14.8	°C/W
T _{JB}	Package θ_{JB}				4.3	
T _{JC}	Package θ_{JC}				12.9	

Table 44 Solder reflow peak temperature

Package	Maximum peak temperature	Maximum time within 5°C of peak temperature
68-pin QFN	260°C	30 seconds

Table 45 Package moisture sensitivity level (MSL), IPC/JEDEC J-STD-2

Package	MSL
68-pin QFN	MSL 3

Package diagram

9 Package diagram

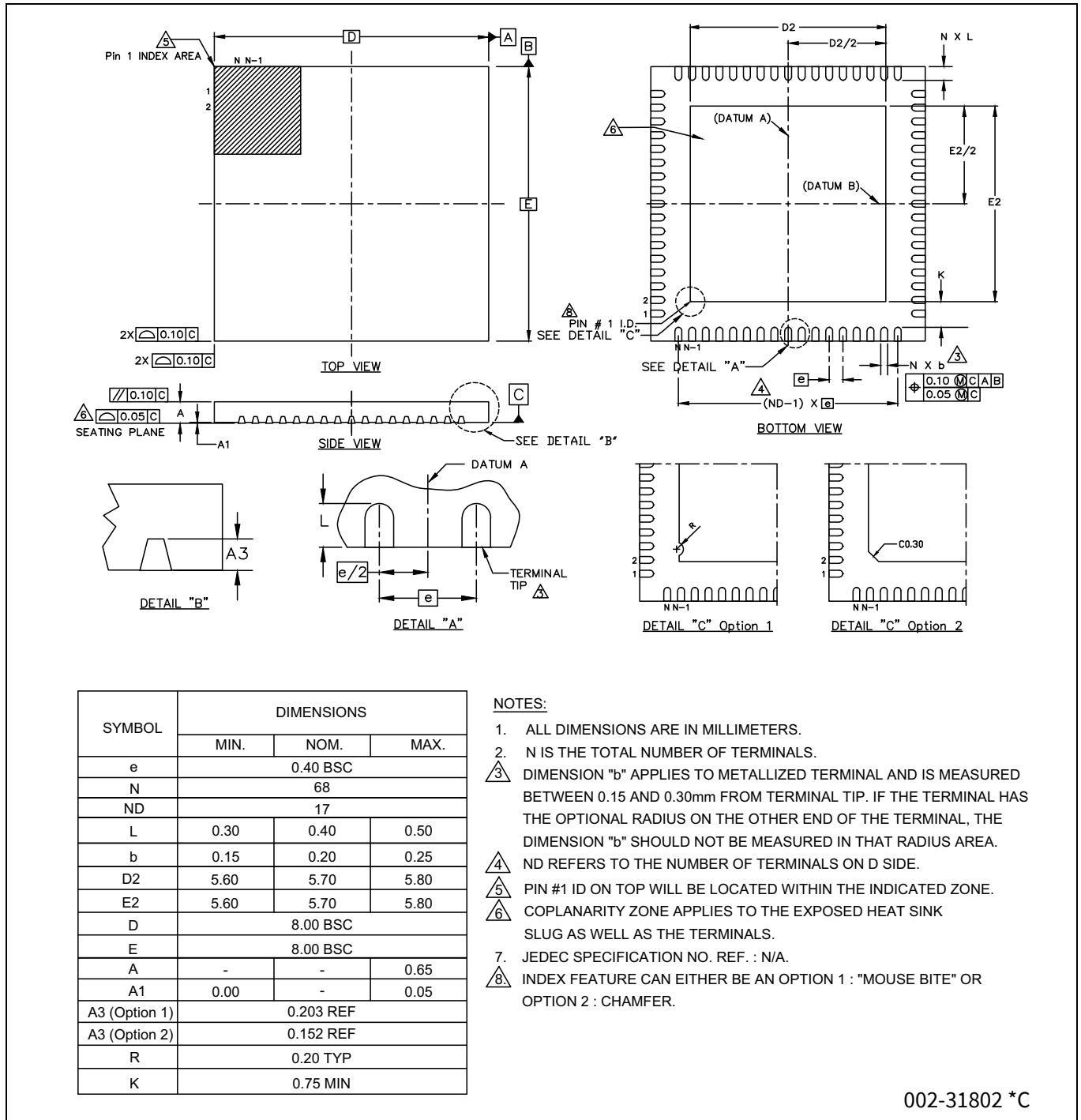

002-31802 *C

Figure 12 68-QFN package drawing (8 x 8 mm)

10 Acronyms

Table 46 Acronyms used in this document

Acronym	Description
ADC	analog-to-digital converter
AFC	Samsung adaptive fast charging
Arm®	advanced RISC machine, a CPU architecture
CPU	central processing unit
CSA	current sense amplifier
DAC	digital-to-analog converter
FCCM	forced continuous current/conduction mode
GPIO	general-purpose input/output
HSDR	high-side driver
I ² C, or IIC	inter-integrated circuit, a communications protocol
IDAC	current DAC
I/O	input/output, see also GPIO
LSDR	low-side driver
MCU	microcontroller unit
OCP	overcurrent protection
OVP	overvoltage protection
PD	power delivery
POR	power-on reset
PSoC™	Programmable system-on-chip
PSM	pulse skipping mode
PWM	pulse-width modulator
RAM	random-access memory
SPI	serial peripheral interface, a communications protocol
SRAM	static random access memory
TCPWM	timer/counter/PWM
Type-C	a new standard with a slimmer USB connector and a reversible cable, capable of sourcing up to 100 W of power
UART	universal asynchronous transmitter receiver, a communications protocol
UFP	upstream facing port
UVP	undervoltage protection
USB	universal Serial Bus
UVLO	under-voltage lockout
ZCD	zero crossing detector

11 Document conventions

11.1 Units of measure

Table 47 Units of measure

Symbol	Unit of measure
°C	degrees Celsius
Hz	hertz
KB	1024 bytes
kHz	kilohertz
kΩ	kilo ohm
Mbps	megabits per second
MHz	megahertz
MΩ	mega-ohm
Msp/s	megasamples per second
μA	microampere
μF	microfarad
μs	microsecond
μV	microvolt
μW	microwatt
mA	milliampere
mΩ	milliohm
ms	millisecond
mV	millivolt
nA	nanoampere
ns	nanosecond
Ω	ohm
pF	picofarad
ppm	parts per million
ps	picosecond
s	second
sps	samples per second



Revision history

Revision history

Document version	Date	Description of changes
*C	2022-10-19	Publish to web.