

# D1FT15A

Schottky Barrier Diodes  
150V, 3A

### Feature

- Small SMD
- High Voltage
- $T_j=175^{\circ}\text{C}$
- Ultra low  $I_R$
- Based on AEC-Q101
- Pb free terminal
- RoHS:Yes

### OUTLINE

Package (House Name): 1F  
Package (JEDEC Code): DO-214AC



### Equivalent circuit

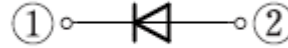

### Absolute Maximum Ratings (unless otherwise specified : $T_l=25^{\circ}\text{C}$ )

Item	Symbol	Conditions	Ratings	Unit
Storage temperature	$T_{stg}$		-55 to 175	$^{\circ}\text{C}$
Junction temperature	$T_j$		-55 to 175	$^{\circ}\text{C}$
Repetitive peak reverse voltage	$V_{RRM}$		150	V
Average forward current	$I_F(AV)$	50Hz sine wave, Resistance load, $T_l=116^{\circ}\text{C}$	3	A
Average forward current	$I_F(AV)$	50Hz sine wave, Resistance load, On alumina substrate, $T_a=25^{\circ}\text{C}$ ※	1.8	A
Average forward current	$I_F(AV)$	50Hz sine wave, Resistance load, On glass-epoxy substrate, $T_a=25^{\circ}\text{C}$ ※	1.3	A
Surge forward current	$I_{FSM}$	50Hz sine wave, Non-repetitive, 1 cycle, Peak value, $T_j=25^{\circ}\text{C}$	60	A

※ : See the original Specifications

**Electrical Characteristics** (unless otherwise specified : Tl=25°C)

Item	Symbol	Conditions	Ratings			Unit
			MIN	TYP	MAX	
Forward voltage	$V_F$	IF=3A, Pulse measurement			0.88	V
Forward voltage	$V_F$	IF=1A, Pulse measurement			0.78	V
Reverse current	$I_R$	VR=150V, Pulse measurement			0.008	mA
Total capacitance	$C_t$	f=1MHz, VR=10V		52		pF
Thermal resistance	Rth(j-l)	Junction to lead			23	°C/W
Thermal resistance	Rth(j-a)	Junction to ambient, On alumina substrate ※			108	°C/W
Thermal resistance	Rth(j-a)	Junction to ambient, On glass-epoxy substrate ※			157	°C/W

※ :See the original Specifications

# CHARACTERISTIC DIAGRAMS

### Forward Voltage

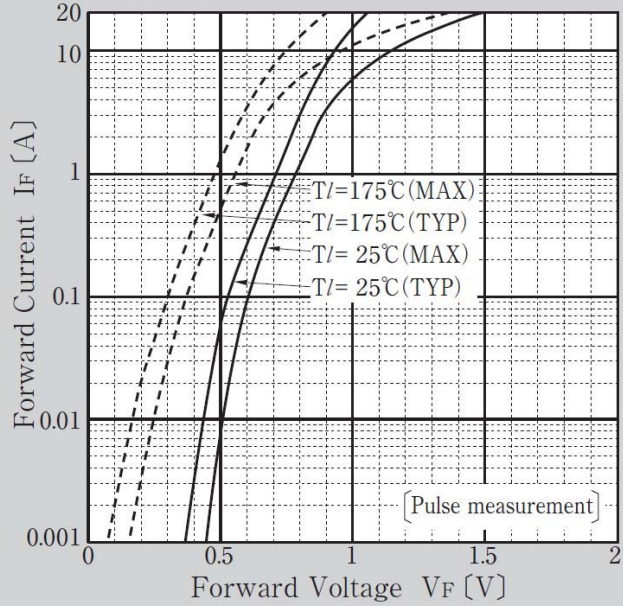

### Reverse Current

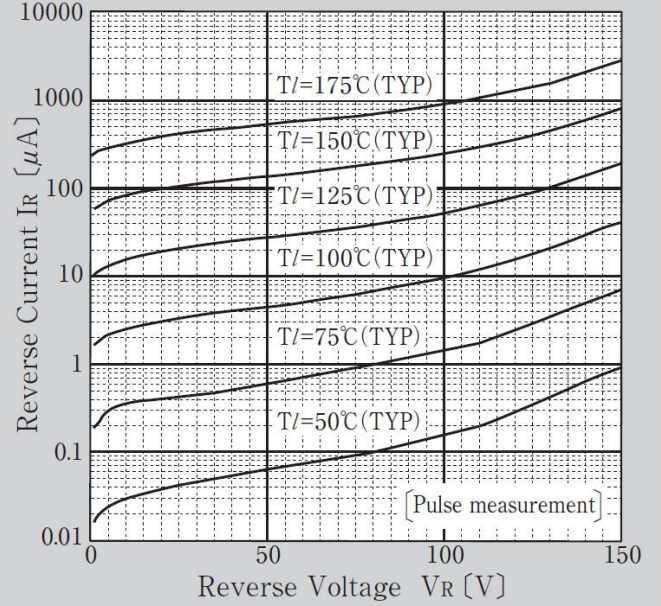

### Forward Power Dissipation

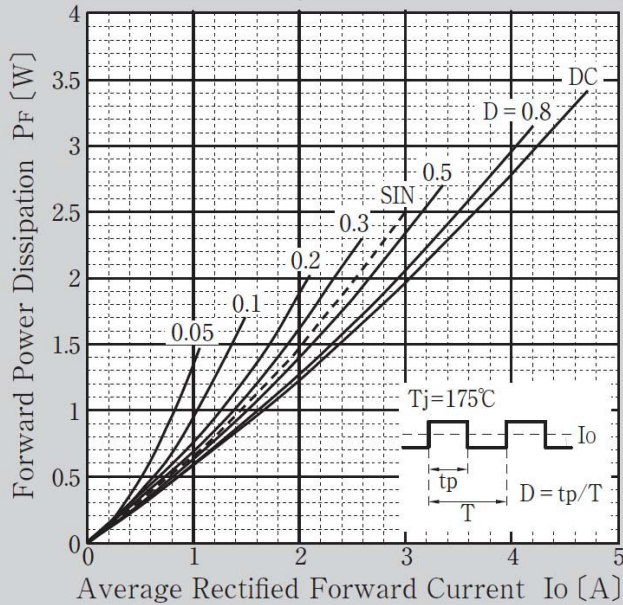

### Reverse Power Dissipation

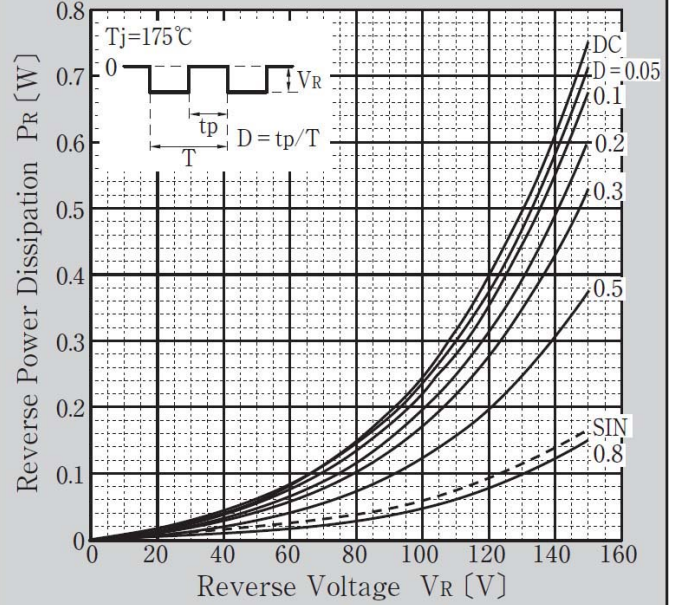

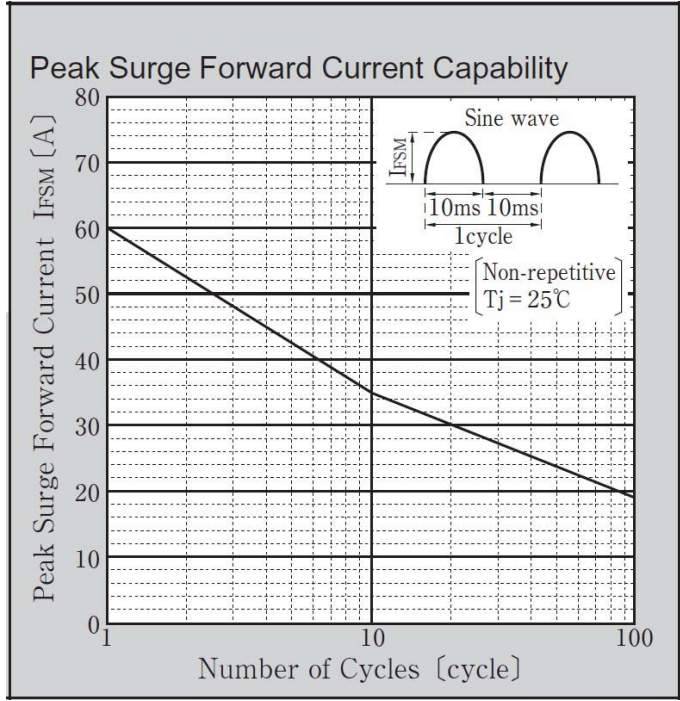
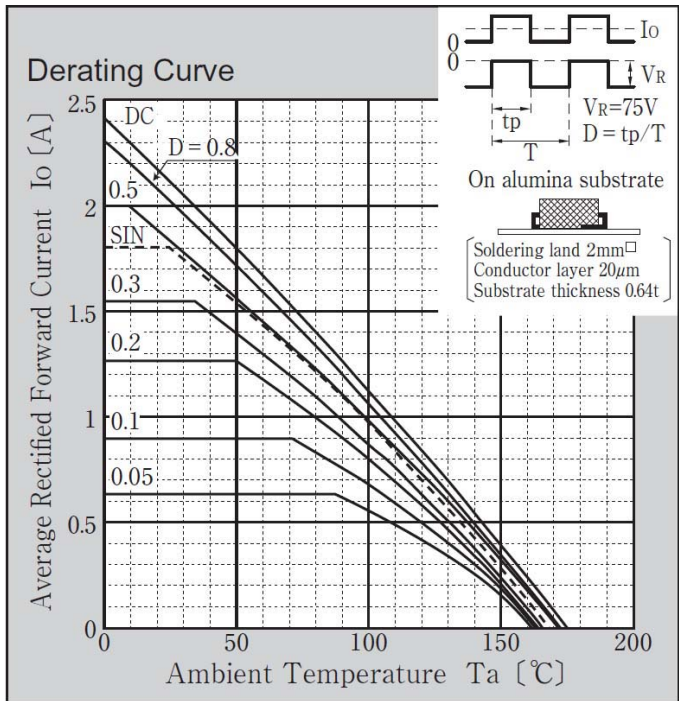
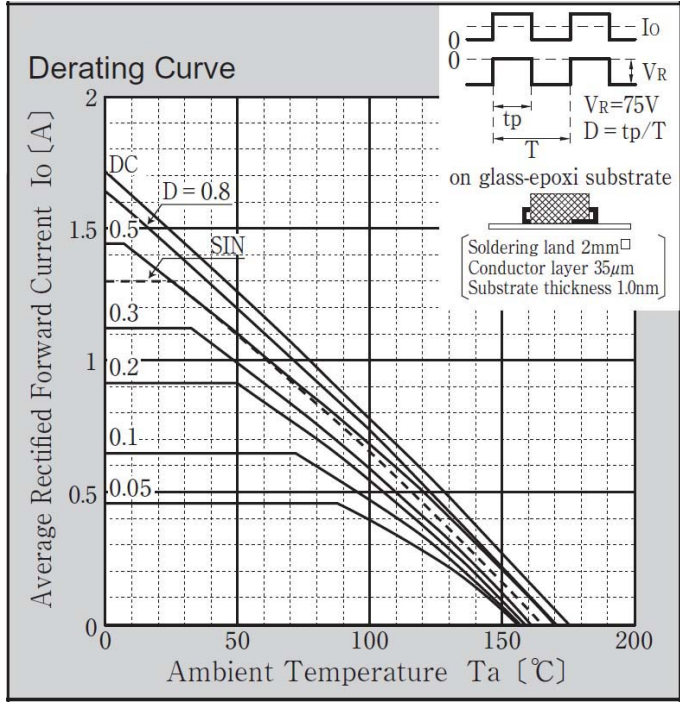
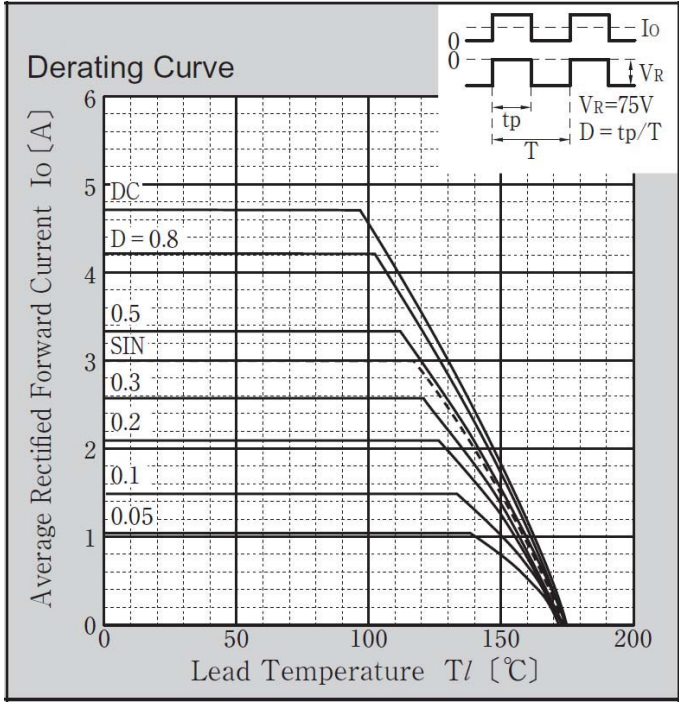

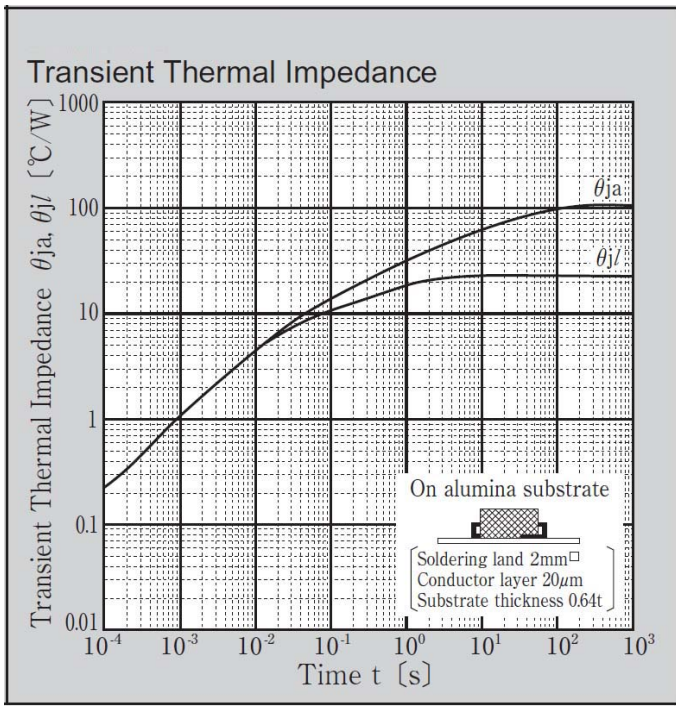
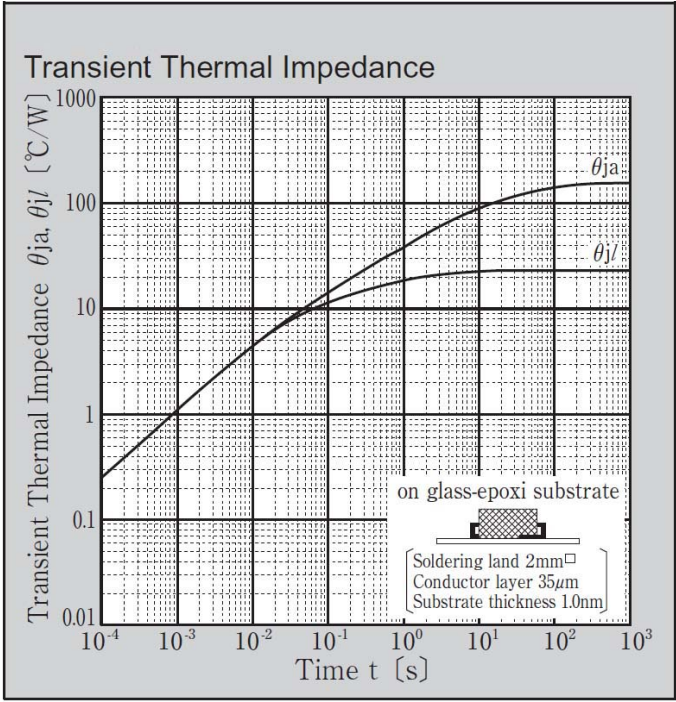
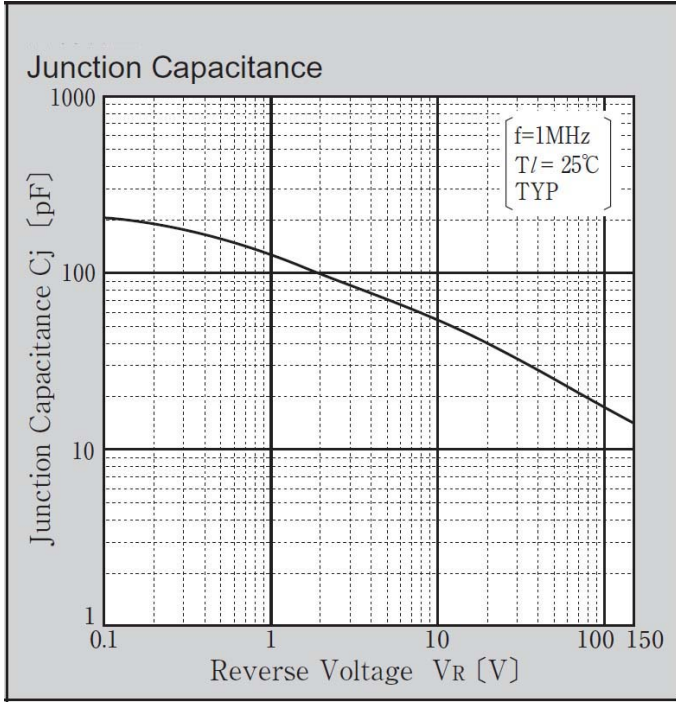

B3

JEDEC Code	DO-214AC
JEITA Code	-
House Name	1F, CF

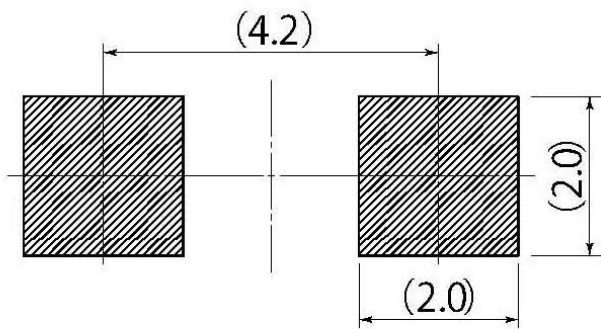
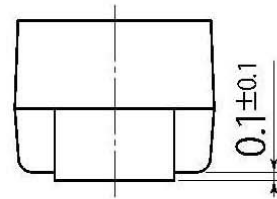
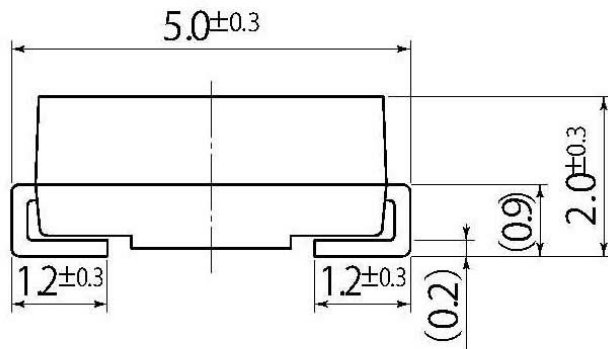
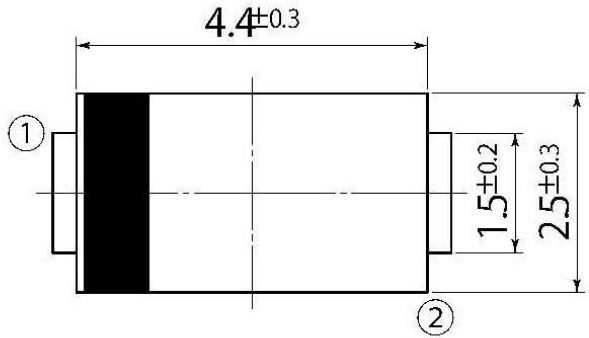

Referential Soldering Pad

• Optimize soldering pad to the board design and soldering condition.