

# User Manual

## DA14531 Development Kit Pro Hardware User Manual

UM-B-114

### Abstract

*Dialog Semiconductor's DA14531 development kit PRO consists of one DA145xx DEVKT-P PRO-Motherboard, FCGQNFN daughterboard and a WLCSP daughterboard (the WLCSP daughterboard must be purchased separately). This user manual describes the system functions of the hardware as well as the guidelines of how to enable or disable features of the DA14531 development kit PRO.*

---

---

**Contents**

<b>Abstract</b> .....	<b>1</b>
<b>Contents</b> .....	<b>2</b>
<b>Figures</b> .....	<b>4</b>
<b>Tables</b> .....	<b>5</b>
<b>1 Terms and Definitions</b> .....	<b>7</b>
<b>2 References</b> .....	<b>7</b>
<b>3 Introduction</b> .....	<b>8</b>
3.1 System Overview .....	10
3.1.1 Features of DA14531 PRO-DB .....	10
3.1.2 Features of DA14531 PRO-MB .....	10
<b>4 Getting to Know DA14531 DK PRO</b> .....	<b>11</b>
4.1 DA14531 PRO-DB .....	11
4.1.1 Power Section .....	13
4.1.2 RF Section .....	15
4.2 PRO-MB (376-18-B) .....	16
4.2.1 USB HUB (U11) .....	18
4.2.2 USB to UART (U12) .....	18
4.2.3 USB to JTAG (U4) .....	19
4.2.4 Voltage Translator .....	20
4.2.5 Power Section .....	21
<b>5 GPIOs and Pin Assignment and Functions of DA14531 DK PRO</b> .....	<b>22</b>
5.1 DA14531 WLCSP17 PRO-DB, Default Setup .....	24
5.2 DA14531 FCGQFN24 PRO-DB, Default Setup .....	25
5.3 PRO-MB Setup .....	27
5.3.1 Reset .....	27
5.3.2 JTAG .....	28
5.3.3 SPI Data Flash (U2) .....	28
5.3.4 UART .....	29
5.3.4.1 Single-wire UART .....	30
5.3.4.2 2-wire UART Configuration .....	30
5.3.4.3 Full UART (4-wire) Configuration .....	31
5.3.5 Push Buttons .....	32
5.3.6 User LED (D5) and C-Trig (Software Cursor) .....	33
5.3.7 mikroBUS 2 Interface .....	34
5.3.8 Arduino Interface .....	35
<b>6 How to Configure Power of DA14531 DK PRO</b> .....	<b>36</b>
6.1 Battery Operation .....	37
6.1.1 Enabling Coin Cell Battery on DA14531 PRO-DB .....	38
6.1.2 Enabling Coin Cell Battery on PRO-MB .....	38
<b>7 First Steps with DA14531 DK PRO</b> .....	<b>40</b>
7.1 Configuration of DA14531 DK PRO with a DA14531 FCGQFN24 PRO-DB .....	40
7.2 Configuration of DA14531 DK PRO with a DA14531 WLCSP17 PRO-DB .....	42
<b>8 Current Measurements</b> .....	<b>43</b>

**DA14531 Development Kit Pro Hardware User Manual**

8.1	Current Measurement Circuit of PRO-MB .....	43
8.2	Power Profiler of Smartsnippet Toolbox .....	44
8.3	Power Profiler Setup .....	45
8.4	Measurements .....	47
8.5	Power Profiler Software Cursors.....	49
8.6	Manual Calibration .....	49
8.7	Accuracy of Current Measurement Circuit.....	51
<b>9</b>	<b>Known Issues .....</b>	<b>53</b>
9.1	Switching Transient Artifacts of Current Measurement Circuit .....	53
9.2	Push Button SW3.....	53
9.3	mikroBUS Wrong Labels.....	54
9.4	4-Wire UART Special Considerations.....	54
<b>Appendix A FCGQFN24 PRO-DB: DA14531-00FXDB-P_(376-04-F2).....</b>		<b>56</b>
A.1	Schematic .....	56
A.2	Components Placement.....	57
<b>Appendix B WLCSP17 PRO-DB: DA14531-00OGDB-P_(376-05-E).....</b>		<b>58</b>
B.1	Schematic .....	58
B.2	Components Placement.....	59
<b>Appendix C PRO-MB .....</b>		<b>60</b>
C.1	Schematic .....	60
C.2	Components Placement.....	64
<b>Appendix D Detailed Description of Hardware Setup.....</b>		<b>65</b>
D.1	DA14531 WLCSP17 PRO-DB, GPIOs Configuration, and R-matrix .....	65
D.2	DA14531 FCGQFN24 PRO-DB, GPIOs Configuration, and R-matrix.....	66
<b>Appendix E SPI Data Flash, JTAG, and Single-Wire UART (Default).....</b>		<b>69</b>
E.1	DA14531 WLCSP17 PRO-DB and PRO-MB Settings.....	69
E.2	DA14531 FCGQFN24 PRO-DB and PRO-MB Settings .....	71
<b>Appendix F Enabling UART, JTAG and 32.768 kHz Crystal.....</b>		<b>75</b>
F.1	UART (2-wire), JTAG, and 32.768 kHz Crystal .....	75
F.2	Full UART and JTAG .....	77
<b>Appendix G Operating the DK PRO at 1.5V (boost mode) .....</b>		<b>79</b>
G.1	Adding external resistor to VLDO Selection (J5) pin header .....	79
G.2	Using external power supply .....	79
G.3	Important Notice For Boost Operation .....	79
<b>Revision History .....</b>		<b>81</b>

## Figures

Figure 1:DK PRO, DA14531-00FXDEVKT-P DK with PRO-MB and the PRO-DBs .....	8
Figure 2: Block Diagram of the DA14531 DK PRO Hardware Platform.....	10
Figure 3: System Block Diagram of DA14531 PRO-DB.....	11
Figure 4: DA14531-00FXDB-P, FCGQFN24 PRO-DB_[376-04-F].....	11
Figure 5: DA14531-00OGDB-P, WLCSP17 PRO-DB_[376-05-E].....	12
Figure 6: DA14531 PRO-DB Power Section.....	13
Figure 7: Power Section of DA14531 PRO-DB.....	14
Figure 8: RF Section of DA14531 PRO-DB.....	15
Figure 9: Modifications Required for Performing RF Measurements.....	15
Figure 10: DA145xx DEVKT-P PRO-MB Block Diagram.....	16
Figure 11: PRO-MB (376-18-x).....	16
Figure 12: USB HUB Circuitry of DA14531 PRO-MB.....	18
Figure 13: USB to UART (U12).....	19
Figure 14: USB to JTAG (U4).....	20
Figure 15: Voltage Translator Circuitry of DA14531 PRO-MB.....	20
Figure 16: Power Topology for DA14531 PRO-MB and PRO-DB.....	21
Figure 17: Power Circuit for DA14531 PRO-MB.....	21
Figure 18: J2, Breakout Header of DA14531 PRO-MB.....	22
Figure 19: J1, Configuration Header on DA14531 PRO-MB.....	23
Figure 20: RESET Circuit on DA14531 PRO-MB.....	27
Figure 21: Reset Pin Assignment on PRO-DBs for FCGQFN24 and WLCSP17.....	27
Figure 22: Optional Debug Port.....	28
Figure 23: SPI Data Flash Circuit in DA14531 DK Pro.....	29
Figure 24: Single-wire UART for DA14531 WLCSP17 PRO-DB.....	30
Figure 25: 2-wire UART Connectivity.....	31
Figure 26: Full UART (4-wire) Connectivity.....	32
Figure 27: Miscellaneous Peripherals.....	32
Figure 28: User LED and Software Trigger Circuit and Jumpers.....	33
Figure 29: MikroBus 2 Circuit.....	34
Figure 30: DA14531 PRO-DB Configuration and DA14531 PRO-MB Jumpers.....	36
Figure 31: BT1 Position (Left). Battery Holder, BC2032-F1, to Be Soldered (Right).....	38
Figure 32: DA14531 PRO-DB Schematic (Left). DA14531 PRO-MB, Header J4 Settings (Right).....	38
Figure 33: BT1 Position on PRO-MB (Left). Battery Holder, BU2032SM-BT-GTR, to Be Soldered (Right).....	39
Figure 34: Default Setup of the DA14531 DK PRO with DA14531 FCGQFN24 PRO-DB.....	40
Figure 35: Default Setup of the DA14531 DK PRO with a DA14531 WLCSP17 PRO-DB.....	42
Figure 36: Current Measurement Circuit of DA14531 PRO-MB.....	43
Figure 37: Current Measurement Presented in Power Profiler of SmartSnippets Toolbox.....	44
Figure 38: SmartSnippets Toolbox Configuration.....	45
Figure 39: Hybrid Configuration.....	45
Figure 40: Power Profiler of SmartSnippets Toolbox Main Window.....	46
Figure 41: Power Profiler Configuration.....	46
Figure 42: Power Profiler Chart Settings.....	47
Figure 43: Free Running Capture.....	47
Figure 44: Triggered Capture.....	48
Figure 45: Oscilloscope Option.....	48
Figure 46: Power Profiler Software Cursors.....	49
Figure 47: Setting Offset to Zero.....	49
Figure 48: Measuring Offset.....	50
Figure 49: Setting Calibration Offset.....	50
Figure 50: Current Measurement Circuit Response, Indicative Graph.....	51
Figure 51: Current Measurement Circuit Inaccuracy, Indicative Graph.....	52
Figure 52: A/D Converter Distortions.....	53
Figure 53: Disable SW3. Remove Jumper from J19:4-5.....	53
Figure 54: mikroBUS Wrong Label.....	54
Figure 55: Full UART Configuration - CTS Issue.....	55
Figure 56: Schematic, FCGQFN24, DA14531-00FXDB-P_(376-04-F2).....	56

**DA14531 Development Kit Pro Hardware User Manual**

Figure 57: Components on Top and Bottom Sides for FCGQFN24, DA14531-00FXDB-P_(376-04-F2)	57
Figure 58: Schematic, WLCSP17, DA14531-00OGDB-P_(376-05-E)	58
Figure 59: Components on Top and Bottom Sides for WLCSP17, DA14531-00OGDB-P_(376-05-E)	59
Figure 60: DA14531 PRO-MB, headers and connectors	60
Figure 61: DA14531 PRO-MB, Current Measurement Circuit	61
Figure 62: DA14531 PRO-MB, JTAG MCU	62
Figure 63: DA14531 PRO-MB, USB Hub, USB to UART IC, and Power Section	63
Figure 64: Components on Top Side of DA14531 PRO-MB	64
Figure 65: System Configuration for DA14531 DK PRO with a DA14531 WLCSP17 PRO-DB (Default)	65
Figure 66: System Configuration for DA14531 DK PRO with a DA14531 FCGQFN24 PRO-DB (Default)	67
Figure 67: System Configuration for DA14531 DK PRO with a DA14531 WLCSP17 PRO-DB (Default)	69
Figure 68: Jumper Settings for PRO-MB (Marked in Red)	70
Figure 69: Resistor and Jumper Settings for DA14531 WLCSP17 PRO-DB	71
Figure 70: System Configuration for DA14531 DK PRO with a DA14531 FCGQFN24 PRO-DB (Default)	72
Figure 71: Jumper Settings for PRO-MB	73
Figure 72: Resistor and Jumper Settings for DA14531 FCGQFN24 PRO-DB	74
Figure 73: Resistor and Jumper Setting for PRO-MB (Top) and DA14531 PRO-DBs (Bottom) to Support 2-Wire UART, JTAG, and 32.768 kHz Crystal	76
Figure 74: Resistor and Jumper Setting for PRO-MB (Top) and DA14531 PRO-DBs (Bottom) to Support Full UART AND JTAG	78
Figure 75: Configuring VLDO for 1.5V boost operation	79
Figure 76: Using external power supply for 1.5V boost operation	79
Figure 77: Examples of SPI Flash power management using (top) analog switch (bottom) directly GPIO	80

**Tables**

Table 1: DK PRO part numbers and description	9
Table 2: PRO-MB to DA14531 Signal Correspondence and Function Multiplexing	23
Table 3: DA14531 WLCSP Signals Assignment	25
Table 4: DA14531 FCGQFN24 PRO-DB and PRO-MB Signals Assignment (Default)	26
Table 5: Configuration Settings for JTAG In DA14531 DK Pro	28
Table 6: Configuration Settings for SPI Data Flash in DA14531 DK Pro	28
Table 7: UART Signals Assignment in DA14531 DK PRO	29
Table 8: Single-wire UART Pin Assignment	30
Table 9: 2-wire UART Pin Assignment	31
Table 10: Full UART Pin Assignment	31
Table 11: Configuration settings for push buttons	33
Table 12: Configuration settings for miscellaneous peripherals	33
Table 13: mikroBUS 2 Signals	34
Table 14: Arduino Signals	35
Table 15: DA14531 DCDC Configuration and Input Voltage	37
Table 16: Jumper Settings for J9	37
Table 17: Accuracy of the Current Measurement Circuit	51
Table 18: DA14531 WLCSP17 PRO-DB Default Setup	66
Table 19: DA14531 FCGQFN24 PRO-DB Default Setup	68
Table 20: Pin Assignment for DA14531 WLCSP17 PRO-DB	69
Table 21: Pin Assignment for DA14531 FCGQFN24 PRO-DB	69
Table 22: The Components for DA14531 DK PRO in WLCSP17 Package	70
Table 23: The Components for DA14531 DK PRO in FCGQFN24 Package	73
Table 24: Pin Assignment for DA14531 WLCSP17 PRO-DB	75

---

**DA14531 Development Kit Pro Hardware User Manual**

Table 25: Pin assignment for DA14531 FCGQFN24 PRO-DB ..... 75  
Table 26: The Components for the Two Packages to Support 2-Wire UART, JTAG, and 32.768 kHz  
Crystal..... 75  
Table 27: Pin Assignment for DA14531 WLCSP17 PRO-DB ..... 77  
Table 28: Pin Assignment for DA14531 FCGQFN24 PRO-DB..... 77  
Table 29: The Components for the Two Packages to Support Full UART and JTAG ..... 77

## 1 Terms and Definitions

UART	Universal Asynchronous Receiver Transmitter
GPIO	General Purpose Input Output (pin)
JTAG	Joint Test Action Group
RF	Radio Frequency
IC	Integrated Circuit
PCB	Printed Circuit Board
PCBA	Printed Circuit Board Assembly
SoC	System on Chip
SWD	Serial Wire Debug
DK	Development Kit
PRO-DB	PRO daughterboard
PRO-MB	PRO Motherboard
FCGQFN24 PRO-DB	PRO daughterboard with DA14531 - FCGQFN24
WLCSP17 PRO-DB	PRO daughterboard with DA14531 - WLCSP17
OTP	One-Time Programmable Memory

## 2 References

- [1] DA14531, [Datasheet](#), Dialog Semiconductor.
- [2] UM-B-083, [SmartSnippets Toolbox User Manual](#), User Manual, Dialog Semiconductor.
- [3] AN-B-075, [DA14531\\_Hardware\\_Guidelines](#), Application Note, Dialog Semiconductor.
- [4] UM-B-151, [Extending Flash Support for DA14531](#), User Manual, Dialog Semiconductor.

### 3 Introduction

This document describes the hardware of DA14531 development kit (DK) PRO. It supersedes the older DA14580/5 DK PRO, providing a richer feature set and an improved performance. The DA14531 DK PRO motherboard fully supports DA14585/6 daughterboards, and the DA14531 DK PRO daughterboards are backwards compatible with the older DA1458x DK PRO motherboard. However, for a better development experience and a full feature support, it is recommended to use the newer DA14531 DK PRO motherboard.

In this document we focus on the DA14531 DK PRO which consists of the following two parts:

- PRO-Motherboard
  - **PRO-MB**: PCBA reference number **376-18-B**
- PRO-daughterboard (PRO-DB) (**two options**, interchangeable)
  - **FCGQFN24 PRO-DB**: it uses **DA14531-FCGQFN24**. PCBA reference number **376-04-F**,
  - **WLCSP17 PRO-DB**: it uses **DA14531-WLCSP17**. PCBA reference number **376-05-E**.

Figure 1 and Table 1 present the part numbers (also ordering code) for the DK PRO

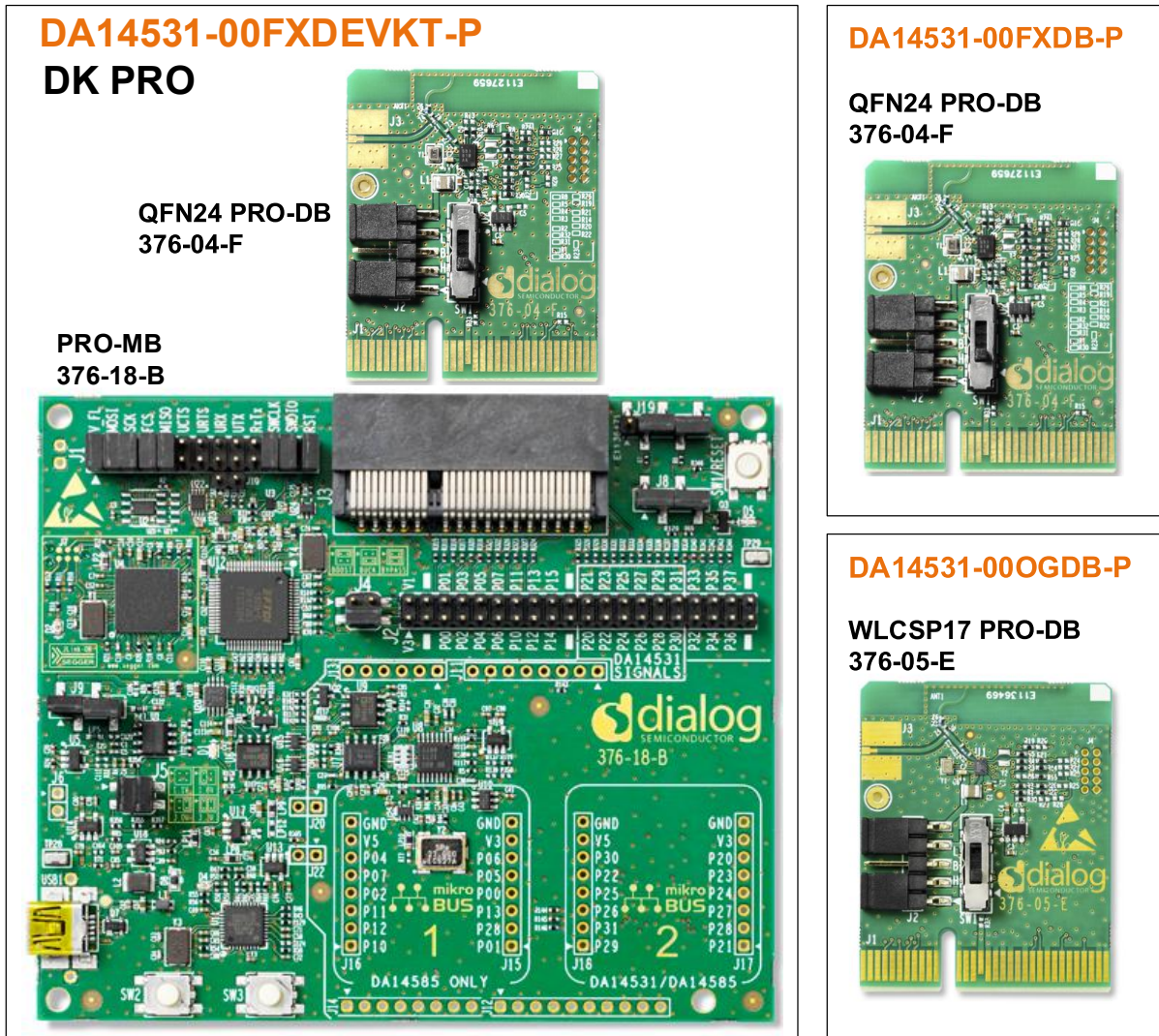

Figure 1:DK PRO, DA14531-00FXDEVKT-P DK with PRO-MB and the PRO-DBs



---

**DA14531 Development Kit Pro Hardware User Manual**

---

**Table 1: DK PRO part numbers and description**

Part number	Description
<b>DA14531-00OGDB-P</b>	WLCSP17 PRO-DB. Bluetooth Low Energy DA14531 WLCSP17 PRO-daughterboard
<b>DA14531-00FXDB-P</b>	FCGQFN24 PRO-DB Bluetooth Low Energy DA14531 FCGQFN24 PRO-daughterboard
<b>DA14531-00FXDEVKT-P</b>	DK-PRO Bluetooth Low Energy Development Kit Pro for DA14531, including PRO-MB and PRO-DB.

**NOTE**

When DA14531-00FXDEVKT-P is ordered, the user gets a set of PRO-MB and a FCGQFN24 PRO-DB. Daughterboard WLCSP17 PRO-DB must be ordered separately.  
A single PRO-MB cannot be ordered.

The following sections guide users to understand the system setup, the different available configuration options, as well as the tools provided to debug, develop, and evaluate the system performance.

### 3.1 System Overview

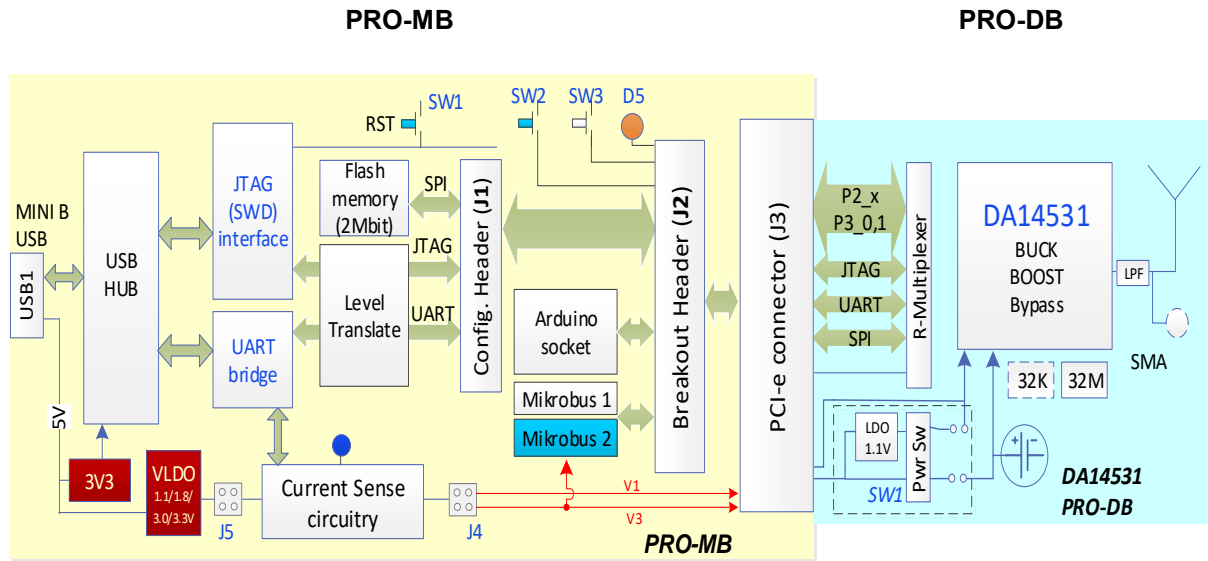

Figure 2: Block Diagram of the DA14531 DK PRO Hardware Platform

#### 3.1.1 Features of DA14531 PRO-DB

- Embedded printed antenna
- RF port output (connector not included)
- DA14531 power mode configuration switch (only for backwards compatibility with DA1458x DK PRO motherboard)
- Current measurement port to connect external measurement equipment
- Onboard JTAG connector
- Support for coin cell battery (battery holder not included)

#### 3.1.2 Features of DA14531 PRO-MB

- A slot to connect a DA14531 PRO-DB which hosts either the DA14531-FCGQFN24 or the DA14531-WLCSP17 SoC
- All the power wiring configurations to allow DA14531 PRO-MB to operate in either Buck, Boost, or Bypass mode
- Dedicated hardware for current measurement that enables Dialog's SmartSnippets Toolbox power profiler software as well as any externally connected power measurement device to profile the power consumption of the system
- Single USB port to provide power and data interfacing to a PC (USB1)
- Onboard JTAG debugger
- Virtual 4-wire UART port
- The DA14531 RESET line is controlled over JTAG by using an onboard push button
- Onboard 2-Mbit SPI data Flash (MX25R2035)
- Multiple voltage options (1.1 V, 1.8 V, 3.0 V, and 3.3V) to supply the DA14531 SoC on the DA14531 PRO-DB
- Support for coin cell battery (battery holder not included)
- User LEDs and push buttons (to be used with a DA14531 FCGQFN24 PRO-DB)
- Voltage translation for the JTAG and UART signals that allows the current leakage during system operation to be eliminated

## 4 Getting to Know DA14531 DK PRO

### 4.1 DA14531 PRO-DB

The system on DA14531 PRO-DB consists of the DA14531 SoC, crystals, power section, and radio section. The system block diagram and the actual components location are presented in [Figure 3](#), [Figure 4](#), and [Figure 5](#).

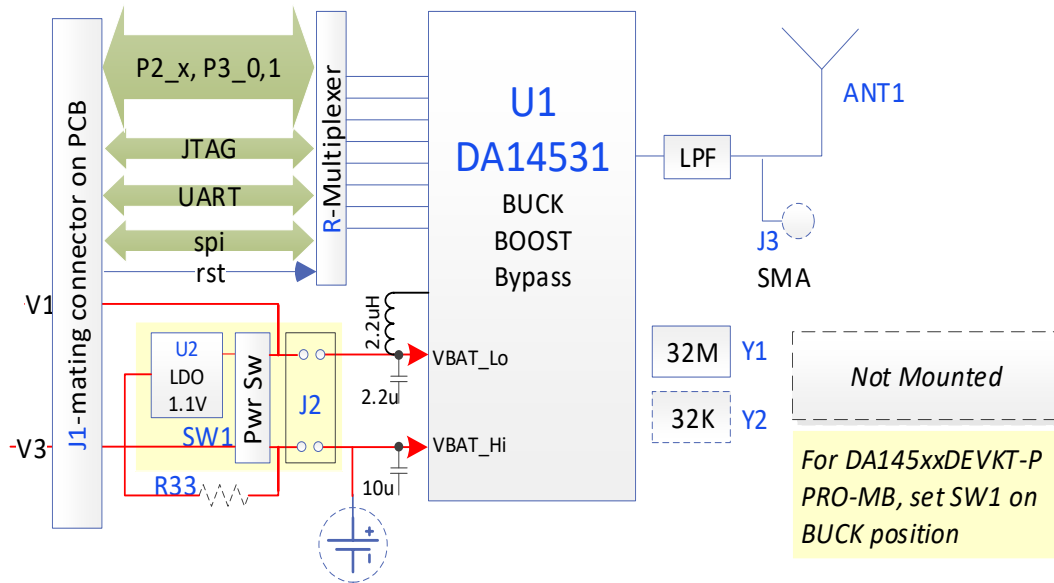

Figure 3: System Block Diagram of DA14531 PRO-DB

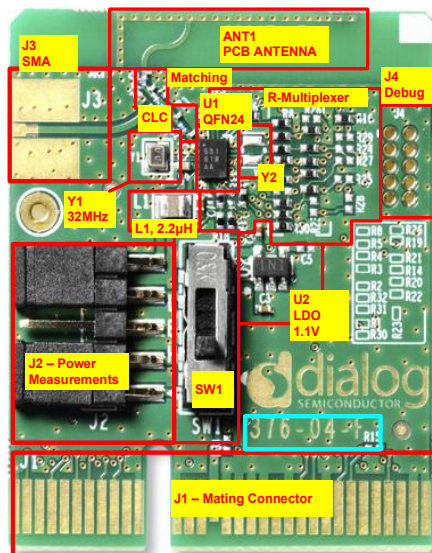

Figure 4: DA14531-00FXDB-P, FCGQFN24 PRO-DB\_[376-04-F]

## DA14531 Development Kit Pro Hardware User Manual

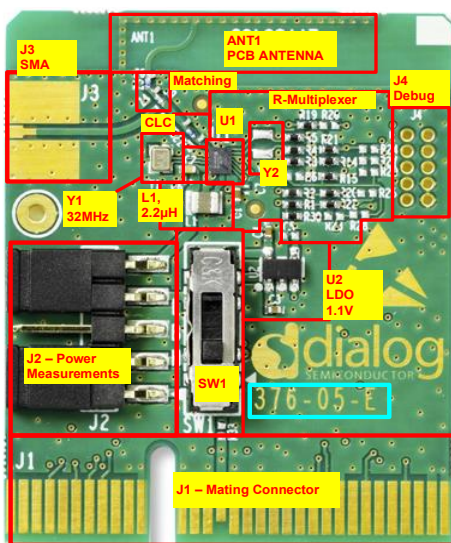

Figure 5: DA14531-00OGB-P, WLCSP17 PRO-DB\_[376-05-E]

- **BLE SoC (U1)**: DA14531 is an ultra-low power SoC integrating a 2.4 GHz transceiver and an ARM CortexM0+™ microcontroller with 48 kB of RAM and 32 kB of One-Time Programmable memory (OTP).
- **32 MHz XTAL (Y1)**: The main clock of the system is generated from a 32 MHz XTAL which is connected to the internal clock oscillator. The selected crystal for this reference is the XRCGB32M000F1H00R0 of Murata.
- **32.768 kHz XTAL (Y2, not assembled by default)**: A crystal of 32.768 kHz can be placed on the pins P0\_3 and P0\_4 of DA14531. A crystal that can be used is the SC20S-7PF20PPM of SEIKO Instruments.

In most applications the DA14531 can run with good accuracy with its internal RC oscillator (RCX) and therefore the XTAL32k is not needed. For applications with more demanding accuracy/drift characteristics, such as timekeeping, using the XTAL32k is considered as a suitable solution.

By default, Y2 is not assembled on PRO-DB. Internal RC clock is used. P0\_3 and P0\_4 are assigned to other SPI data flash (mounted on PRO-MB).

For assembling and utilizing Y2, refer to [Appendix F](#).

- **RF section**: see section [4.1.2](#).
- **R-Multiplexer**: A group of 16 resistors of 0 Ω can be placed/removed as needed in order to hardwire various peripherals to the DA14531 pins as desired ([Appendix D](#)).

To complete a configuration, it is necessary to set/remove jumpers on the DA14531 PRO-MB accordingly. The default settings are presented in section [5](#).

**4.1.1 Power Section**

The power circuit of DA14531 PRO-DB is designed to support two generations of PRO-MBs:

- **PRO-MB:** there is no need for the additional circuit. The DCDC power configuration and the voltage applied to DA14531 SoC are arranged on the PRO-MB (see section 6). In this case, SW1 must be always set to BUCK position.
- **In this document the operation with DA14531-00FXDEVKT-P is presented.**

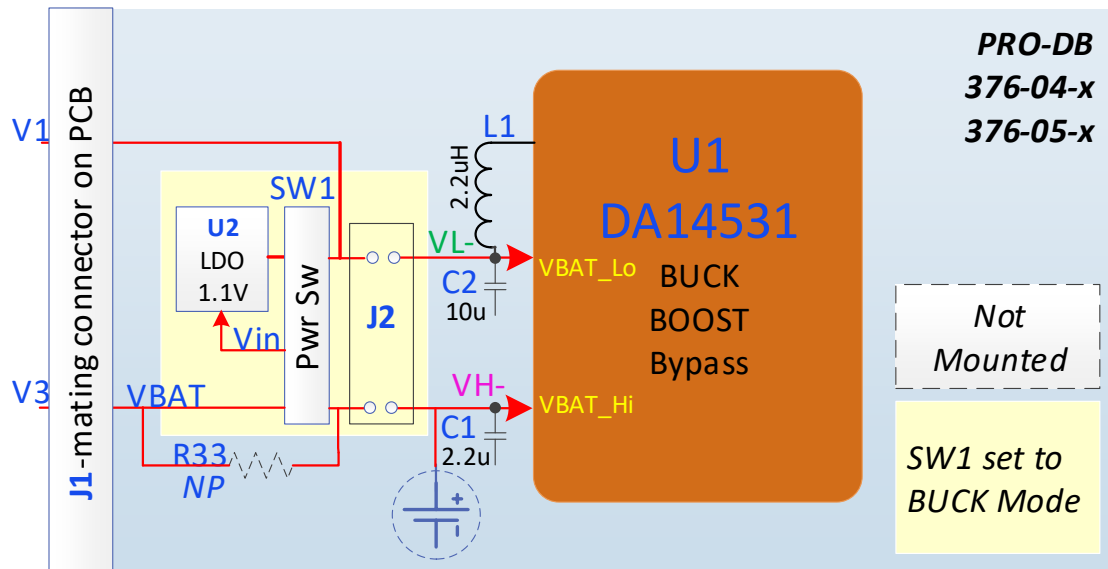

**Figure 6: DA14531 PRO-DB Power Section**

**Components:**

- **U2:** it is an LDO which generates  $V_{LDO} = 1.1\text{ V}$ . U2 is supplied from  $V_{in}$  voltage rail and it is enabled only when SW1 is set for Boost mode. Please notice that the quiescent current of U2 is measured from the power measurement of PRO-MB. It is disabled for the use with PRO-MB.
- **J2:** it is used for connecting external power measurement equipment. For current measurements of sub- $\mu\text{A}$  range, users can insert an external equipment. When no external equipment is applied, jumpers must be applied between 1 and 2 as well as between 4 and 5.
- **L1:** inductor for the DA14531 DCDC converter in Buck or Boost mode of operation.
- **C1:** input capacitor for buck mode and output capacitor for boost mode. As input capacitor this must be equal to  $2.2\ \mu\text{F}$ . As an output capacitor, the effective capacitance must be at least  $1\ \mu\text{F}$ .
- **C2:** input capacitor for boost mode and output capacitor for buck mode. For the PRO-daughterboard, this capacitor is set to  $10\ \mu\text{F}$ .
- **SW1:** it is a power switch of three positions. Settings:
  - Setting SW1 to position H (Buck) connects the  $V_{BAT\_High}$  and  $V_{BAT\_Low}$  pins of DA14531 to the voltage rails V1 and V3 of the PRO-MB
  - Setting SW1 to position B (Bypass) connects both  $V_{BAT\_High}$  and  $V_{BAT\_Low}$  pins of DA14531 to the voltage rail V3 of the PRO-MB
  - Setting SW1 to position L (Boost) connects the  $V_{BAT\_Low}$  pin of DA14531 to the voltage rail generated from U2 on the PRO-DB
  - **For DA14531-00FXDEVKT-P, SW1 must be set to H position (Buck)**

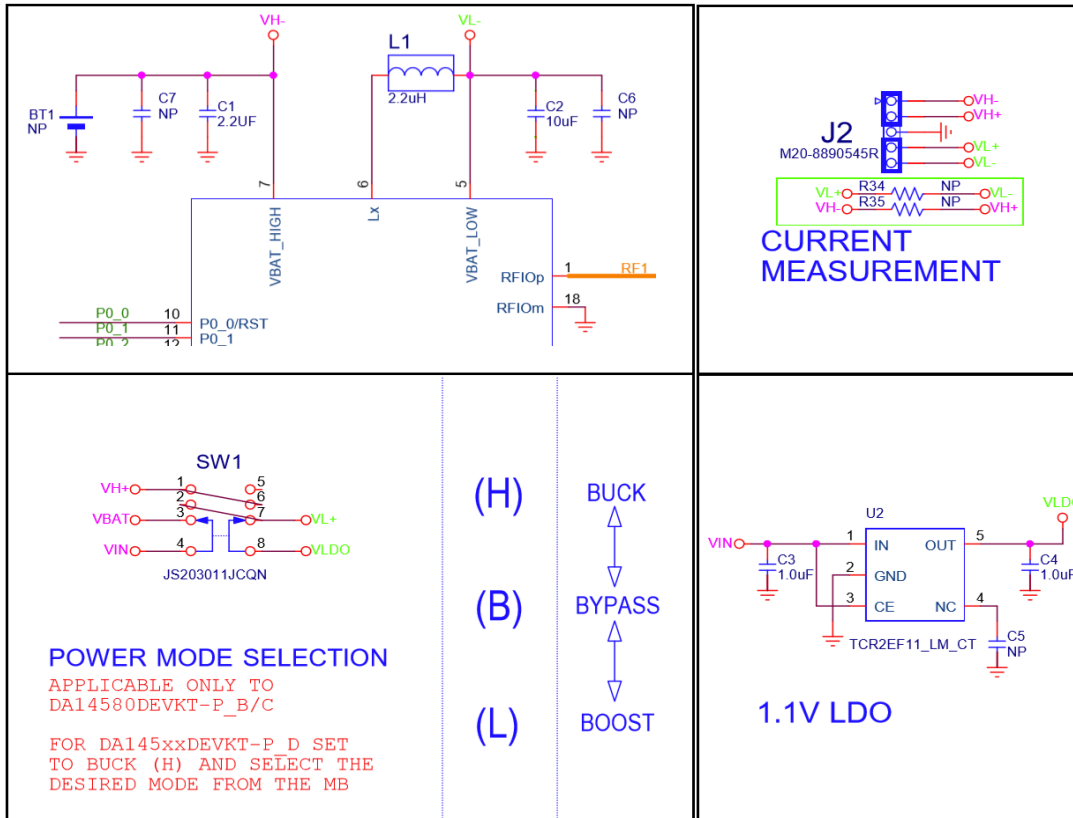
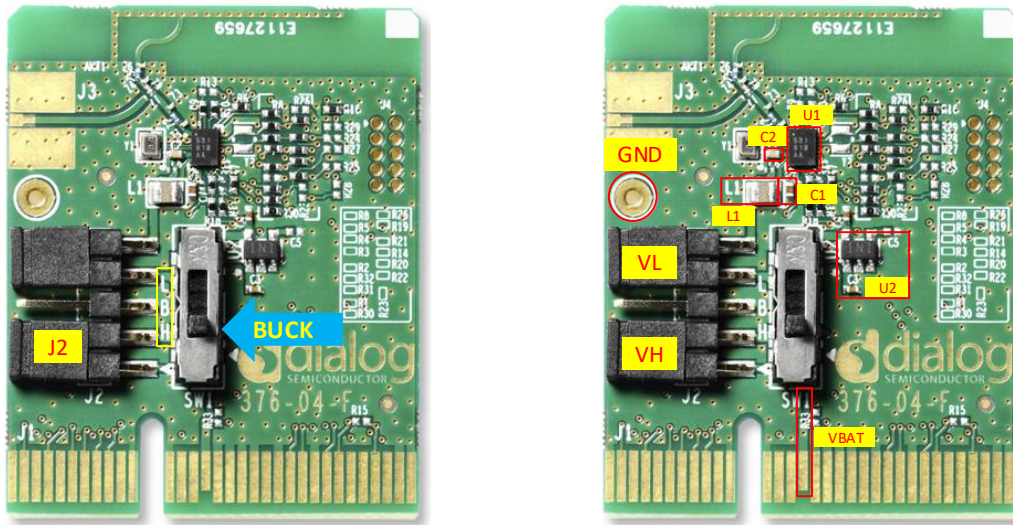

Figure 7: Power Section of DA14531 PRO-DB

#### 4.1.2 RF Section

A printed F-antenna (ANT1) is used as the radiating element for the DA14531 PRO-DB.

The DA14531 RFIO pin is connected to the printed antenna through a RF stripline and a matching circuit.

To conduct RF measurements, please proceed with the following hardware modifications (Figure 9):

- Remove Z9
- Assemble Z7 = 10 pF
- Assemble J3, SMA Female Socket 50  $\Omega$  Board Edge ([142-0761-861](http://www.cinchconnectivity.com) of Cinch Connectivity Solutions Johnson)

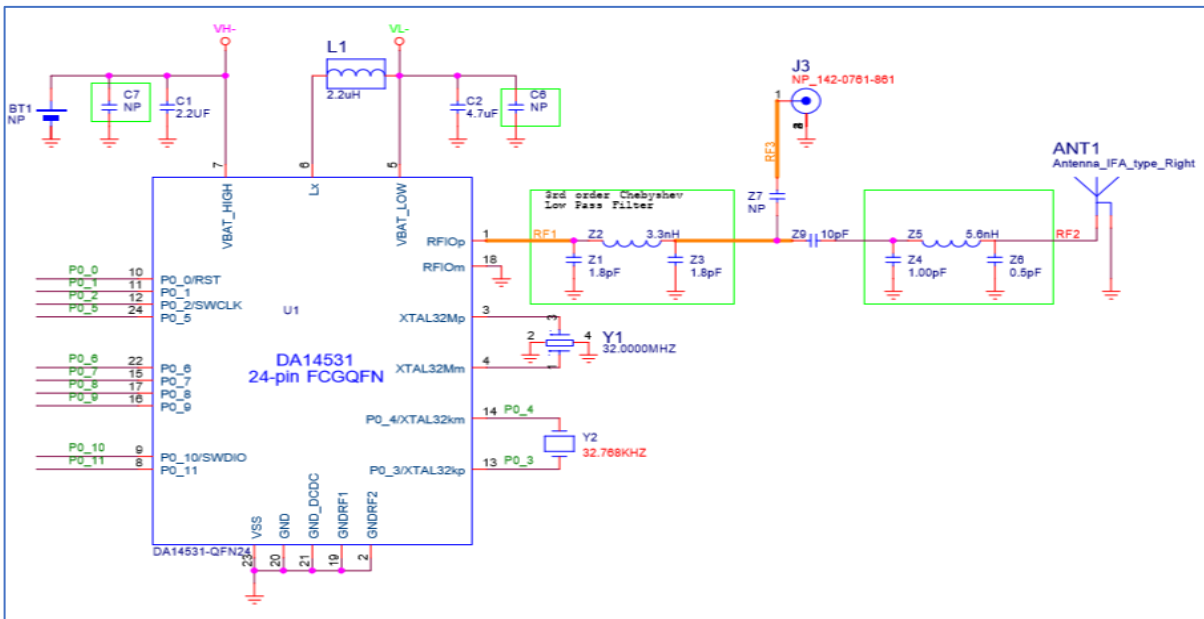

Figure 8: RF Section of DA14531 PRO-DB

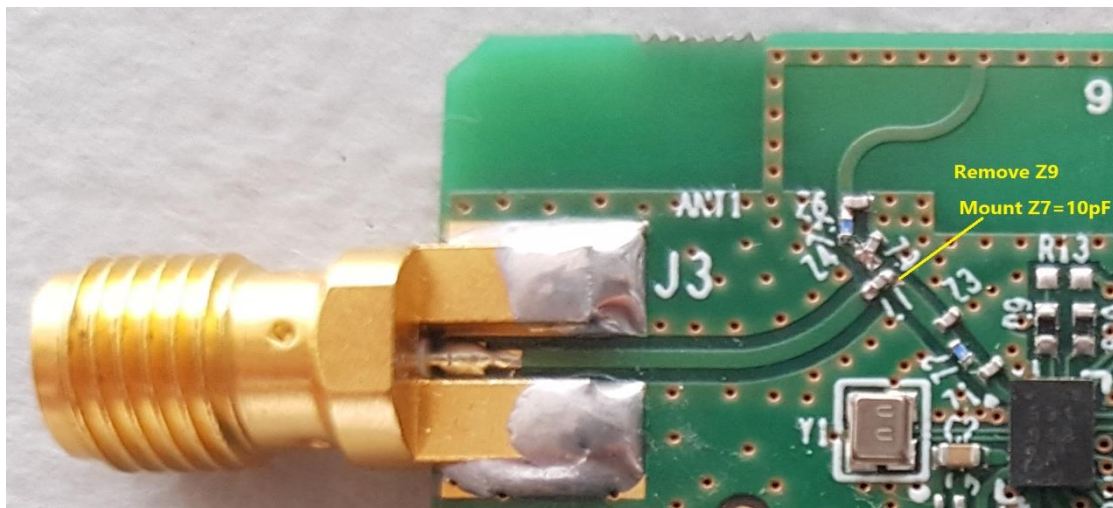

Figure 9: Modifications Required for Performing RF Measurements

#### 4.2 PRO-MB (376-18-B)

The block diagram and the actual component locations of the PRO-MB of DA14531-00FXDEVKT-P DK PRO are presented on Figure 10 and Figure 11, respectively.

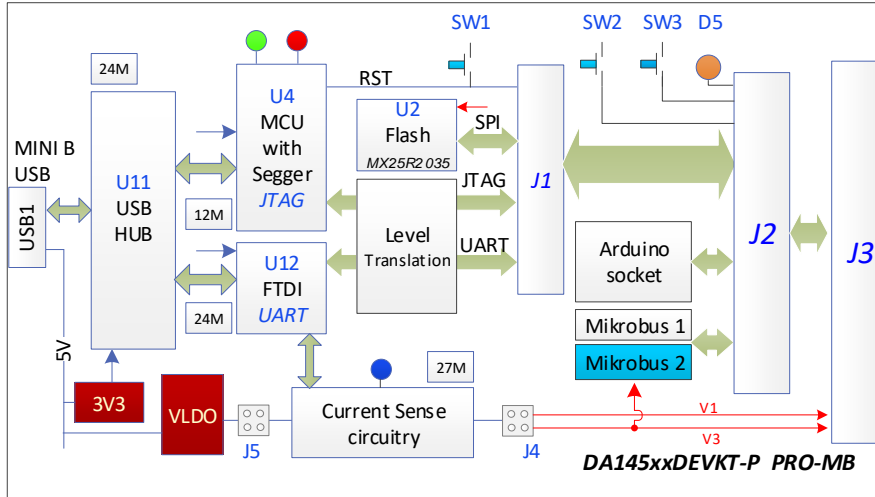

Figure 10: DA145xx DEVKT-P PRO-MB Block Diagram

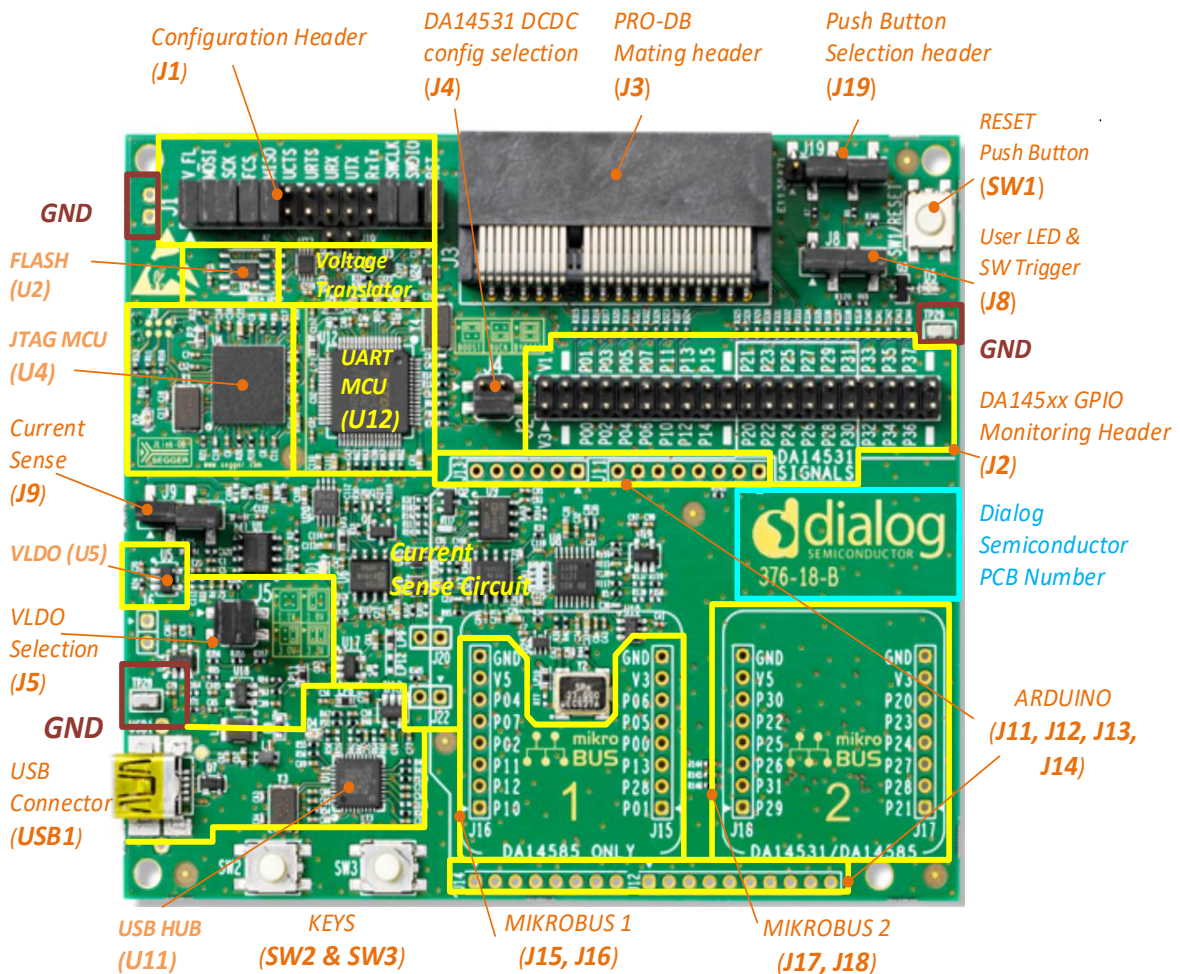

Figure 11: PRO-MB (376-18-x)



---

**DA14531 Development Kit Pro Hardware User Manual**

---

- **USB Hub (U11):** connects JTAG and UART interfaces to the PC.
- **USB to UART (U12):** provides communication between DA14531 UART port and PC. It also transfers the current measurement samples to PC.
- **USB to JTAG (U4):** provides communication between DA14531 JTAG and PC.
- **USB Connector (USB1):** mini-USB connector for power supply and data interfacing to the PC.
- **Configuration Header (J1):** wiring of the available peripherals to the DA14531 pins is done with the help of jumpers on J1 (for default configurations) or with jumper wires from J1 to J2 when custom pin assignments of the peripherals to DA14531 pins are desired.
- **DCDC Configuration (J4):** selects either Boost, Buck, or Bypass mode for DA14531.
- **PRO-DB Mating Header (J3):** a connector that accepts the DA145xx PRO-DB board.
- **Push Button Selection Header (J19):** configures the assignment of onboard push buttons to certain DA14531 pins.
- **Reset Push Button (SW1):** push button used to reset DA14531.
- **User LED and C-Trig (J8):** enables use of the onboard LED (D5) and the software cursor, see section [5.3.6](#)
- **GPIO Monitoring Header (J2):** exposes all the pins of the PRO-DB to allow wiring for custom configurations as well as monitoring of the hardware signals.
- **ARDUINO:** socket for plugging in an Arduino board. It consists of J11, J12, J13, and J14. It is multiplexed with mikroBUS (to be used with DA14531-FCGQFN24).
- **MikroBUS1 (J15 and J16):** the first socket for plugging a mikroBUS click.
- **MikroBUS2 (J17 and J18):** the second socket for plugging a mikroBUS click.
- **Push Buttons (SW2 and SW3):** general use push buttons.
- **VLDO Selection (J5):** selects the output voltage generated for the PRO-DB board (1.1 V, 1.8 V, 3.0 V, or 3.3 V)
- **Current Sense Circuit:** monitors the current of PRO-DB. It is described in section [8.1](#).
- **Current Sense (J9):** enables the current sense circuit (jumpers mounted by default). Also, it allows the simultaneous connection of an external current measurement instrument in order to measure and profile the current consumption of D14531.
- **RxTx Single Wire UART (J10):** Generates RxTx single wire UART by shorting UTX and URX through a 1 K $\Omega$  resistor. Jumpers must be applied to from J10.1 to J1.15 and to from J10.2 to J15.17.
- **J6:** manual enable of USB hub voltage regulator. Not in use by default.
- **J20:** monitoring current sense circuit. Not mounted. No functional use.
- **J22:** it can provide 6.0 V to PRO-DB. Not mounted. No functional use.

### 4.2.1 USB HUB (U11)

The USB HUB of DA14531 PRO-MB is implemented by U11, USB2512B. This chip is supplied with 3.3 V from U13.

The signal PWR\_ENABLE is generated from U11 and it is an active high signal. It enables the power components (LDOs and DCDC converter) for UART, JTAG, and the current sensing circuit. The system will power up only after the USB HUB has enumerated properly.

Its operation is indicated via the green LED D4 on DA14531 PRO-MB. A 24 MHz crystal (Y3) is required for the chip operation.

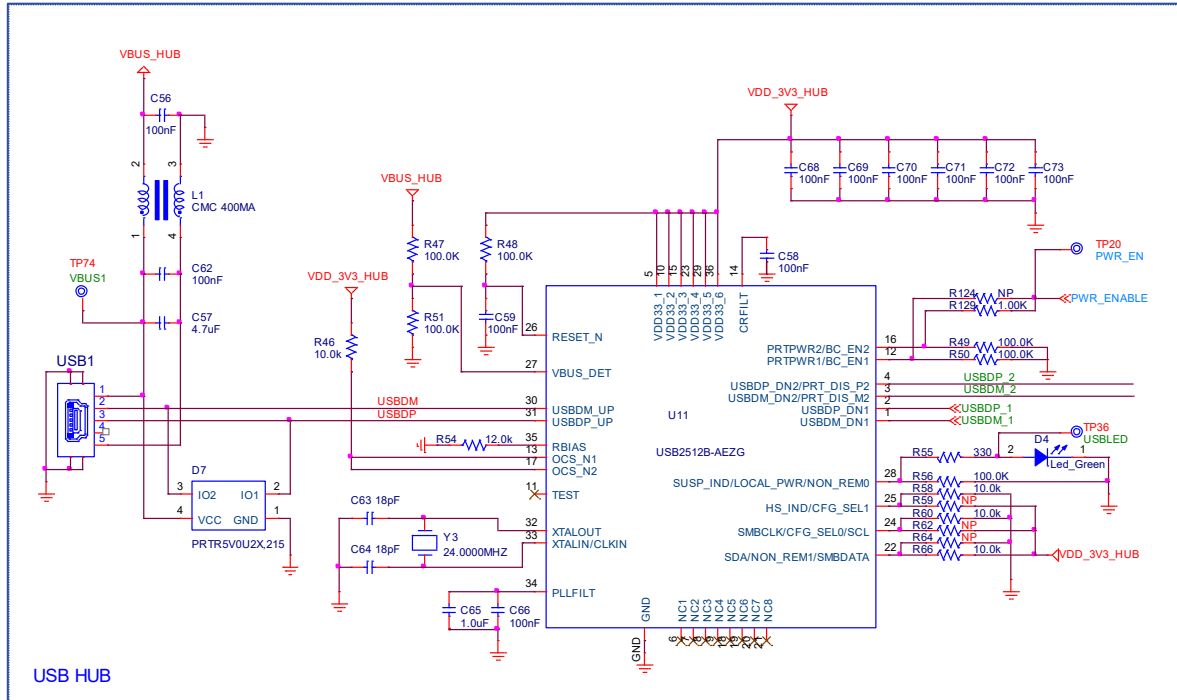

Figure 12: USB HUB Circuitry of DA14531 PRO-MB

### 4.2.2 USB to UART (U12)

The USB to UART function is implemented by U12, FT232HL. This chip is supplied with 3.3 V from U14. A 12 MHz crystal (Y4) is required for the chip operation.

Functions served by U12 are the following:

- Connecting a PC to the UART port of DA14531 SoC
- Connecting a PC to the current sensing circuitry:
  - SPI connection with ADC (U8)
  - Software cursor triggering (C\_TRIG)
- Reset capability of the DA14531 SoC through the T\_RESET signal (not enabled)

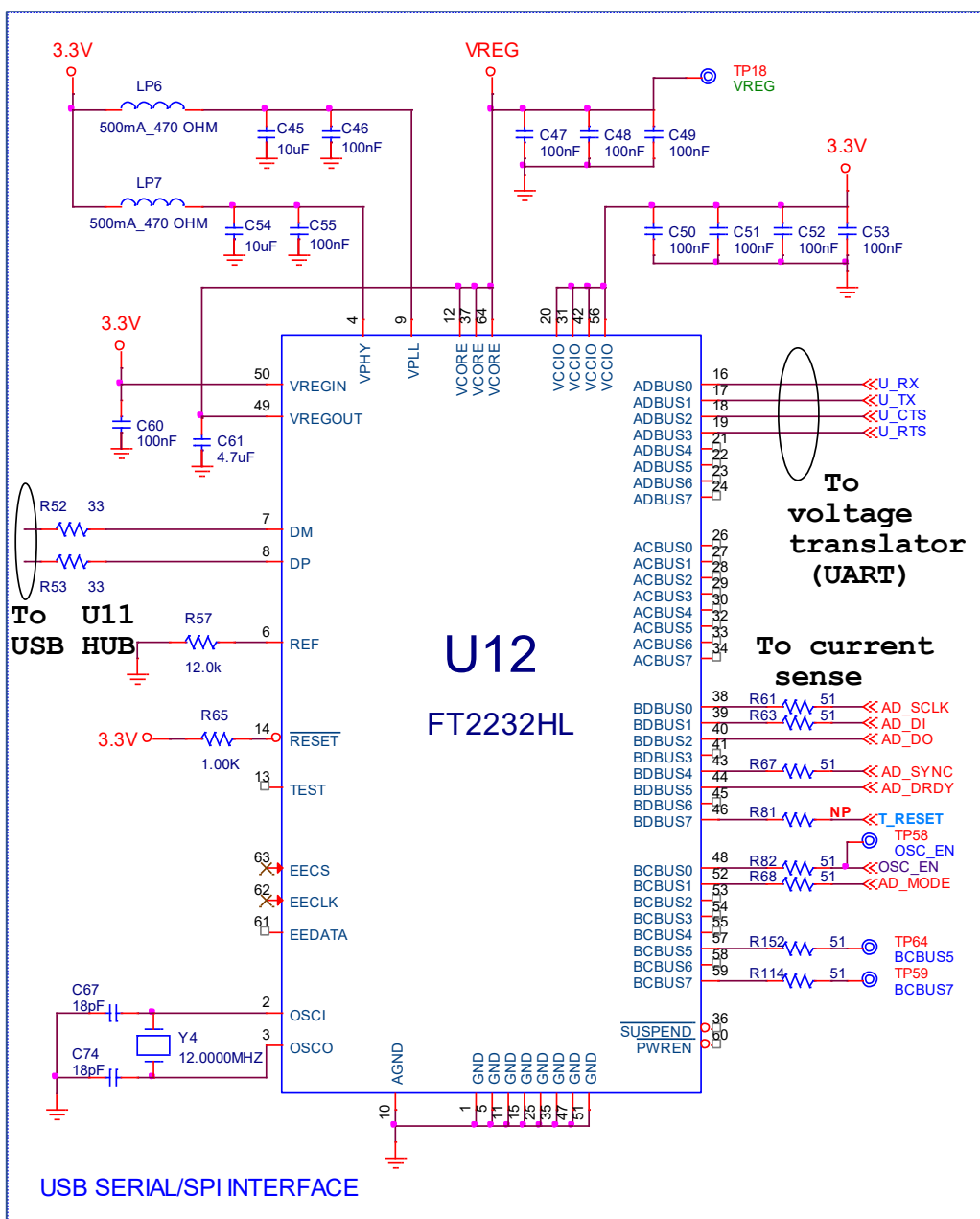

Figure 13: USB to UART (U12)

### 4.2.3 USB to JTAG (U4)

The USB to JTAG function is implemented by U4, SAM3U2CA. On the ROM of U4, software from SEGGER is loaded. Its operation is indicated via the green LED D2 on the DA14531 PRO-MB. This chip is supplied with 3.3 V from U14. U14 is enabled by the PWR\_ENABLE signal.

Functions served by U4 include:

- Connecting a PC to the JTAG port of DA14531 SoC
- Reset capability of the DA14531 SoC through the T\_RESET signal

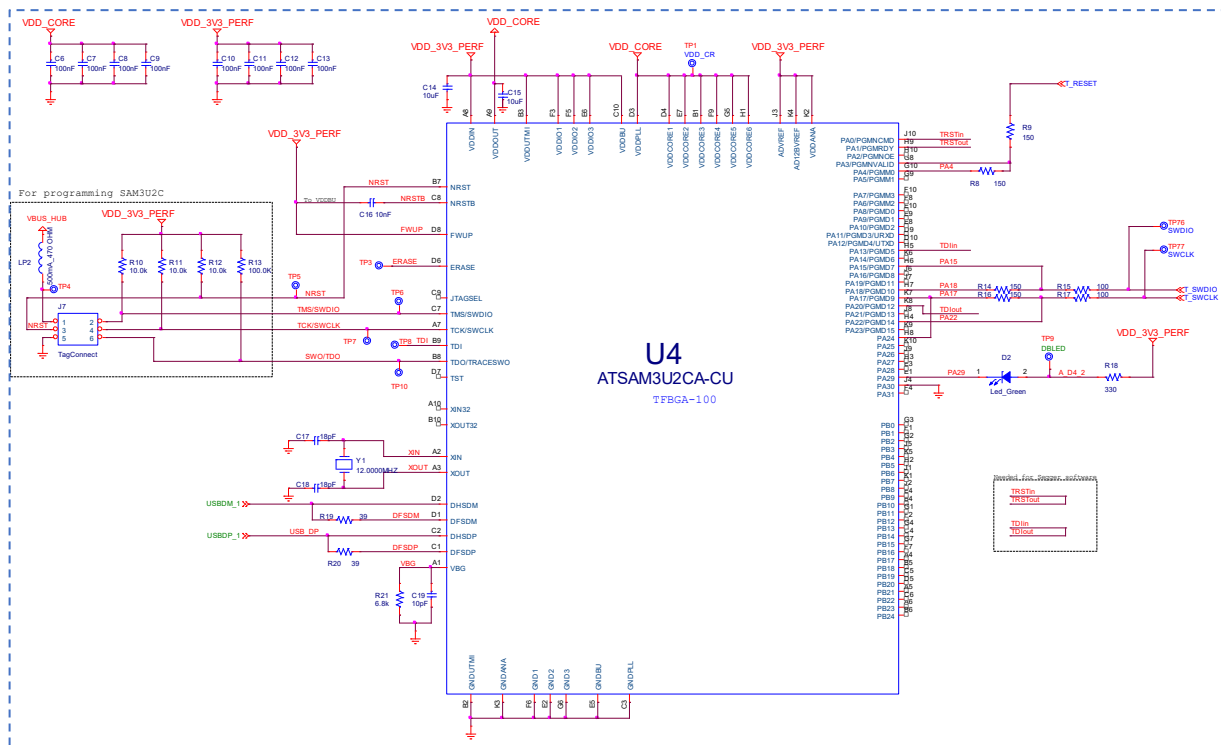

Figure 14: USB to JTAG (U4)

#### 4.2.4 Voltage Translator

- Voltage translation is applied to the UART and JTAG signals. The voltage translation is from 3.3 V to V<sub>DDIO</sub> and vice versa.
- V<sub>DDIO</sub> is generated from U1A, where V<sub>3</sub> (V<sub>BAT\_HIGH</sub>) is used as a reference. Consequently, there is no additional power consumption on the power circuitry of DA14531 PRO-MB due to voltage translation.

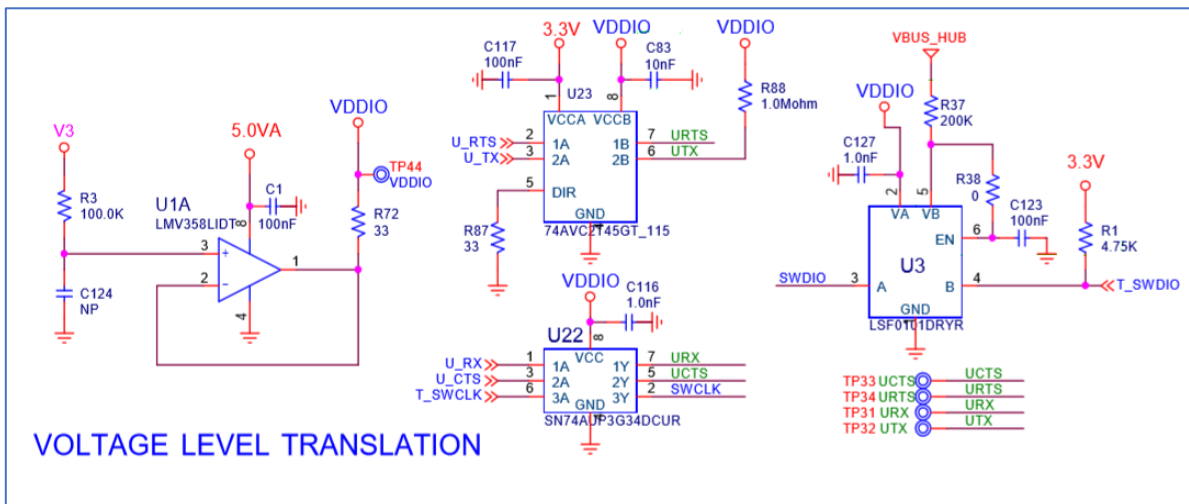

Figure 15: Voltage Translator Circuitry of DA14531 PRO-MB

#### 4.2.5 Power Section

- The DA14531 SoC in the DA14531 PRO-MB is supplied from the  $V_{LDO}$  voltage rail generated from U5, LDO.
- $V_{LDO}$  can be set to four different voltage levels. This is arranged by J5 settings.
- Generated power flows through the current sensing circuitry to the DA14531 PRO-DB power supply pins:
  - V1 is connected to  $V_{BAT\_LOW}$
  - V3 is connected to  $V_{BAT\_HIGH}$
- By applying proper jumpers on header J4, users can enable buck, boost, or bypass mode of operation for the DA14531 DCDC converter.
- For power configuration settings, refer to section 6.

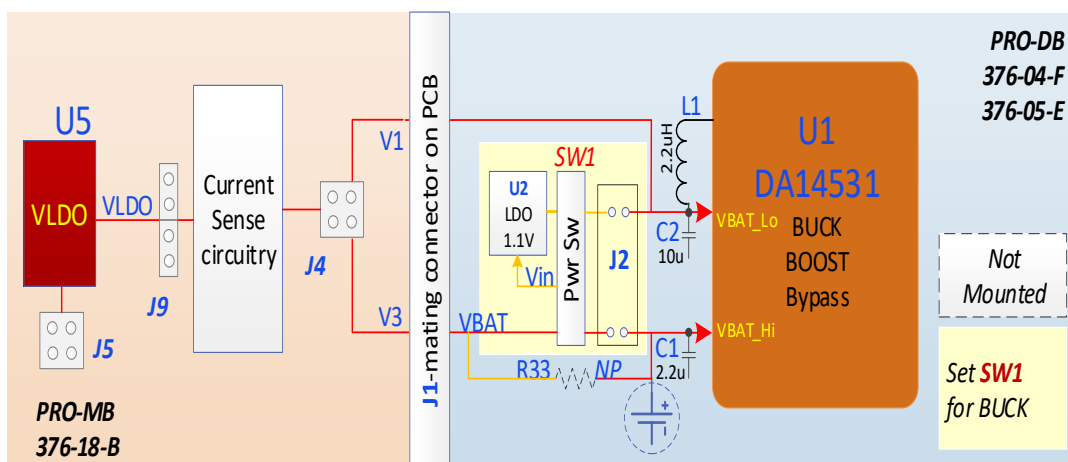

Figure 16: Power Topology for DA14531 PRO-MB and PRO-DB

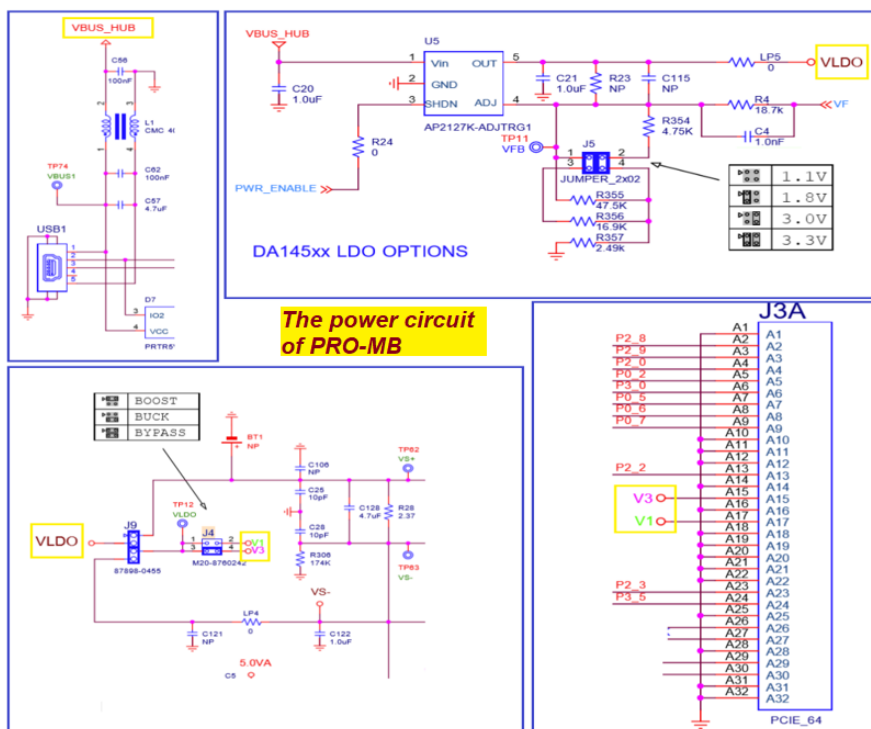

Figure 17: Power Circuit for DA14531 PRO-MB

## 5 GPIOs and Pin Assignment and Functions of DA14531 DK PRO

All signals of the DA14531 PRO-DBs are provided to DA14531 PRO-MB. The signal names are specific for the PRO-MB and do not have the same names as the signals of the PRO-DBs. The reason is that the PRO-MB can be used for both DA14531 SoC and DA1458x family of SoCs, whereas DA14531 SoC has fewer pins than DA1458x SoCs.

Please note that signals of DA14531 SoC (P0\_0 to P0\_10) are provided to ports 2 and 3 of the PRO-MB (P2\_0 to P2\_9, P3\_0, and P3\_1). So, on the breakout header **J2** of the PRO-MB, the pins of DA14531:

- P0\_0 to P0\_11 are mapped to P2\_x, P3\_0 and P3\_1 for FCGQFN24
- P0\_0 to P0\_5 are mapped to P2\_0 to P2\_5 for WLCSP17

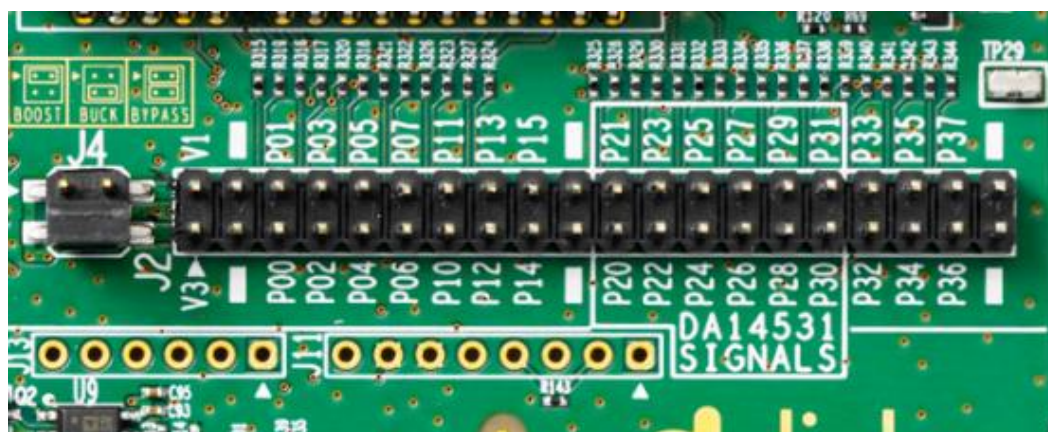
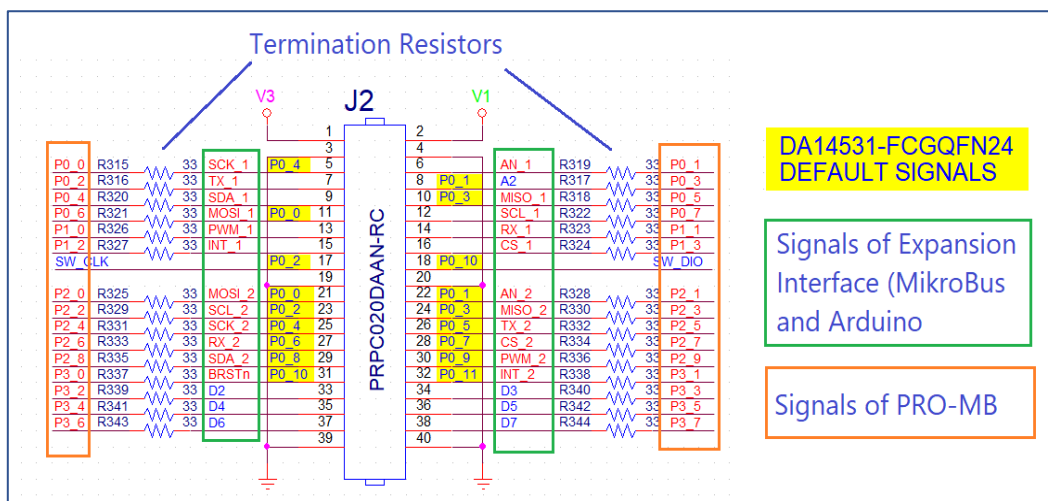

Figure 18: J2, Breakout Header of DA14531 PRO-MB

Due to the low GPIO count, function multiplexing is applied. Every function of the DA14531 DK PRO is practically dependent on the PRO-MB GPIO configuration, as the configuration of the PRO-DB requires soldering and de-soldering of resistors.

The PRO-MB configuration is realized with jumpers or cables. J1 on the PRO-MB is the main configuration header (Figure 19).

PRO-DB configuration is also feasible. Please refer to Appendix D.

DA14531 Development Kit Pro Hardware User Manual

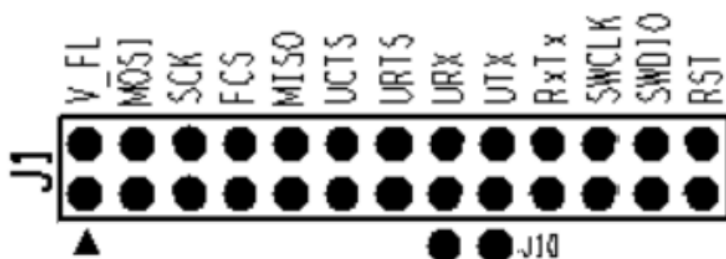

Figure 19: J1, Configuration Header on DA14531 PRO-MB

The DA14531 PRO-DB GPIO pin assignment as well the configuration settings for the GPIOs of the PRO-MB are presented below. The DA14531 DK PRO signals connectivity is depicted in the [Table 2](#) where the GPIOs of DA14531 PRO-DB are mapped to the breakout header (J2) and the configuration header (J1) of PRO-MB.

[Table 2](#) also presents the available functions for every GPIO of DA14531.

Table 2: PRO-MB to DA14531 Signal Correspondence and Function Multiplexing

PRO_MB Signals	DA14531 PRO-DB Signals		Function 1		Function 2		Function 3	
	J2	FCGQFN24	WLCSP17	Enabled by J1 Settings		mikroBUS & Arduino (MBUS & ARD)		Enabled by Jumpers
P0_0	P0_4	P0_4	SCK	J1:5-6 (Default)	SCK_1	MBus1/ARD		
P0_1	No available pins from DA14531				AN_1	MBus1/ARD		
P0_2					TX_1	MBus1/ARD		
P0_3	P0_1	P0_1	FCS	J1:7-8 (Default)	A2	ARD		
P0_4	P0_0	P0_0	UTX	J1:17 to J2:21 (cable)	SDA_1	MBus1/ARD		
P0_5	P0_3	P0_3	MISO	J1:9-10 (Default)	MISO_1	MBus1		
			URX	J1:15-16				
P0_6	P0_0	P0_0	MOSI	J1:3-4 (Default)	MOSI_1	MBus1	SW2	J19:1-2
			UCTS	J1:11-12				
P0_7	P0_4	P0_4	URTS	J1:13 to J2:25 (cable)	SCL_1	MBus1/ARD		
SWCLK	P0_2	P0_2	SWCLK	J1:21-22 (Default)				
SWDIO	P0_10	P0_5	SWDIO	J1:23-24 (Default)				
P1_0	P0_9				PWM_1	MBus1/ARD	LED	J8:3-4 (Default)
P1_1	P0_10				RX_1	MBus1/ARD	SW3	J19:4-5
P1_2	No Available pins from DA14531				INT_1	MBus1/ARD		

PRO_MB Signals	DA14531 PRO-DB		Function 1		Function 2		Function 3	
	Signals							
J2	FCGQFN24	WLCSP17	Enabled by J1 Settings		mikroBUS & Arduino (MBUS & ARD)		Enabled by Jumpers	
P1_3	P0_11				CS_1	MBus1	C-TRIG	J8:1-2 (Default)
P2_0	P0_0	P0_0	RST	J1: 25-26 (Default)	MOSI_2	MBus2		
P2_1	P0_1	P0_1			AN_2	ARD		
P2_2	P0_2	P0_2			SCL_2	MBus2/ARD		
P2_3	P0_3	P0_3			MISO_2	MBus2		
P2_4	P0_4	P0_4			SCK_2	MBus2		
P2_5	P0_5	P0_5	RxTx	J1:19-20	TX_2	MBus2/ARD		
				J10:1 to J1:15				
				J10:2 to J1:17				
P2_6	P0_6				RX_2	MBus2/ARD		
P2_7	P0_7				CS_2	MBus2/ARD		
P2_8	P0_8				SDA_2	MBus2/ARD		
P2_9	P0_9				PWM_2	MBus2		
P3_0	Note1				BRSTn	MBus1,2/ARD		
P3_1	P0_11				INT_2	ARD	SW2	J19:2-3 (Default)
P3_2	No available pins from DA14531				D2	ARD		
P3_3					D3	ARD		
P3_4					D4	ARD		
P3_5					D5	ARD		
P3_6					D6	ARD		
P3_7					D7	ARD		

**Note 1** P3\_10 is assigned to P0\_10 (SWDIO) through the resistor R11 on DA14531 FCGQFN24 PRO-DB. R11 is not populated.

### 5.1 DA14531 WLCSP17 PRO-DB, Default Setup

- The default configuration of DA14531 WLCSP17 PRO-DB is:
  - Reset
  - JTAG and SPI data flash
- Dual UART or full UART are not enabled. To enable UART, refer to section 5.3.4
- Crystal 32.768 kHz is not enabled. To enable the crystal 32.768 kHz, refer to section F.1
- Resistor matrix for DA14531 WLCSP17 PRO-DB (and DA145xx-DEVKT-P PRO-MB signals are presented in E.1.
- Please note that signals of DA14531 WLCSP17 PRO-DB are renamed on PRO-MB. The reason is that PRO-MB can be used for the PRO-DBs of DA1458x family



- For detailed description of the connection capabilities of DA14531 WLCSP17 PRO-DB circuitry, please refer to [Appendix D](#)

**Table 3: DA14531 WLCSP Signals Assignment**

DA14531 PRO-DB WLCSP17	PRO-MB			
	Signal Name	J1 & J2 Pin Number	Functions Enabled by Jumpers	
			Function	J1 Pins
P0_0	P2_0	J2:21		
	RST	J1:26	RST	J1: 25-26 (Default)
	P0_6	J2:11	MOSI (Flash)	J1:3-4 (Default)
P0_1	P2_1	J2:22		
	P0_3	J2:8	FCS (Flash)	J1:7-8 (Default)
P0_2	P2_2	J2:23		
	SW_CLK	J1:22	SWCLK	J1:21-22 (Default)
P0_3	P2_3	J2:24		
	P0_5	J2:10	MISO (Flash)	J1:9-10 (Default)
P0_4	P2_4	J2:25		
	P0_0	J2:5	SCK (Flash)	J1:5-6 (Default)
P0_5	P2_5	J2:26		
	SW_DIO	J1:24	SWDIO	J1:23-24 (Default)

## 5.2 DA14531 FCGQFN24 PRO-DB, Default Setup

- The default configuration of DA14531 FCGQFN24 PRO-DB is:
  - Reset
  - JTAG
  - SPI data flash
  - and single wire UART
 To enable these functions, apply the appropriate jumpers to the DA14531 PRO-MB
- Dual UART or full UART are not enabled. To enable UART, see section [5.3.4](#)
- Crystal 32.768 kHz is not enabled. For enabling crystal 32.768 kHz, refer to section [F.1](#)
- Resistor matrix for FCGQFN24 PRO-DB and DA145xx-DEVKT-P PRO-MB signals are presented in section [E.2](#).
- Please note that signals of DA14531 FCGQFN24 PRO-DB are renamed on PRO-MB. The reason is that PRO-MB can be used for the daughterboards of DA1458x family
- For detailed description of the connection capabilities of DA14531 FCGQFN24 PRO-DB circuitry, please refer to [Appendix D](#)

## DA14531 Development Kit Pro Hardware User Manual

Table 4: DA14531 FCGQFN24 PRO-DB and PRO-MB Signals Assignment (Default)

DA14531 PRO-DB FCGQFN24	PRO-MB						
	Signal Name	J1&J2 Pin Number	Functions Enabled by Jumpers		Multiplexed Functions		
			Function	Jumpers	Function	Interface	Header Pins Numbers
P0_0	P2_0	J2:21			MOSI_2	MBus2	J17:6
	RST	J1:26		J1: 25-26 (Default)			
	P0_6	J2:11	MOSI (Flash)	J1:3-4 (Default)			
P0_1	P2_1	J2:22			AN_2	Arduino	J12:9
	P0_3	J2:8	FCS (Flash)	J1:7-8 (Default)			
P0_2	P2_2	J2:23			SCL_2	MBus2 & Arduino	J18:5
	SW_CLK	J1:22	SWCLK	J1:21-22 (Default)			
P0_3	P2_3	J2:24			MISO_2	MBus2	J17:5
	P0_5	J2:10	MISO (Flash)	J1:9-10 (Default)			
P0_4	P2_4	J2:25			SCK_2	MBus2	J17:4
	P0_0	J2:5	SCK (Flash)	J1:5-6 (Default)			
P0_5	P2_5	J2:26 and J1:20	RxTx	J1: 19-20 J10:1-J1:15 J10:2-J1:17	TX_2	MBus2 & Arduino	J18:4 to J12:4
P0_6	P2_6	J2:27			RX_2	MBus2 & Arduino	J18:3 to J12:5
P0_7	P2_7	J2:28			CS_2	MBus2 & Arduino	J17:3 to J12:6
P0_8	P2_8	J2:29			SDA_2	MBus2 & Arduino	J18:6 to J14:1
P0_9	P2_9	J2:30			PWM_2	MBus2	J18:1
	P1_0	J2_13	LED	J8:3-4 (Default)			
P0_10	SW_DIO	J1:24	SWDIO	J1:23-24 (Default)			
P0_11	P3_1	J2:31	SW2	J19:2-3 (Default)	INT_2	Arduino	J14:2
	P1_3	J2:16	C_TRIG	J8:1-2 (Default)			

#### 5.3 PRO-MB Setup

The PRO-MB provides several debug interfaces and tools that can be used for development.

The DA14531 pin assignment for the available functions are presented in the following sections.

##### 5.3.1 Reset

At power-on and before booting in the chip, reset is active high, and it is assigned to on P0\_0. After booting, reset assignment and operation is handled by software.

- On a DA14531 PRO-DB, the reset signal provided by the PRO-MB is connected to P0\_0 for WLCSP17 and FCGQFN24 through a 1 kΩ resistor
- On the PRO-MB, reset can be enabled either from the JTAG interface (T-RESET) or by pressing the push button SW1

Please note that, to enable reset on an application, P0\_0 must be enabled in both hardware and software

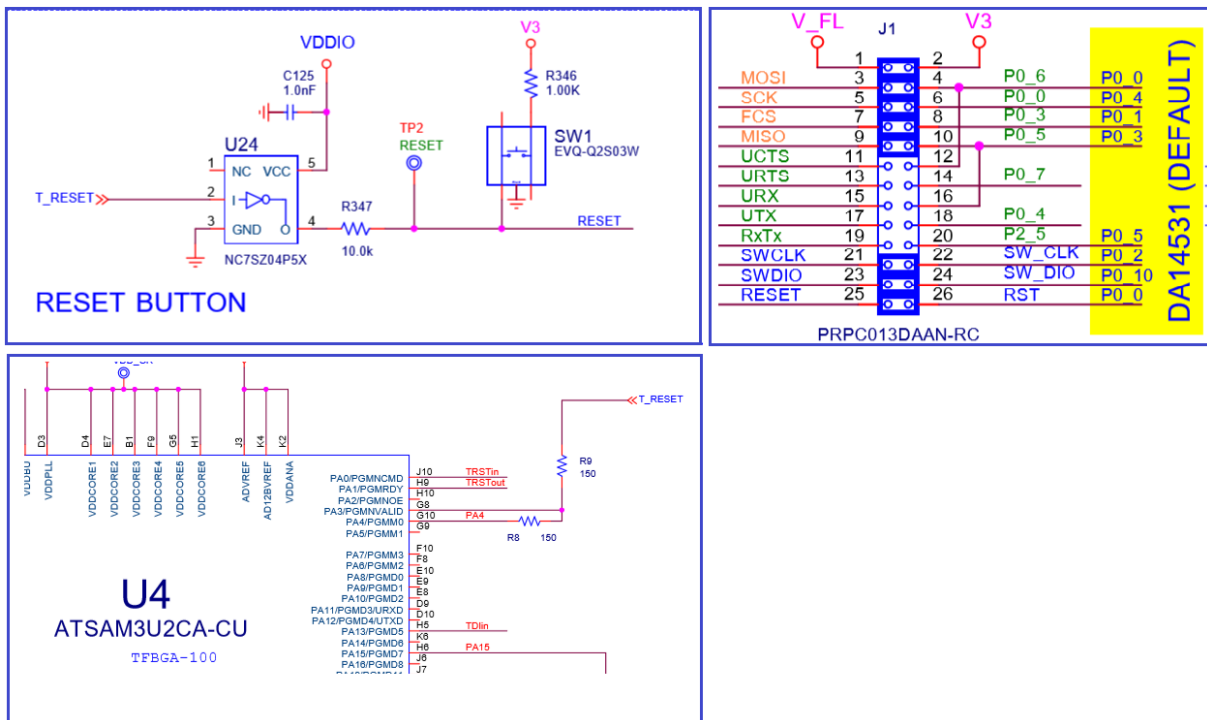

Figure 20: RESET Circuit on DA14531 PRO-MB

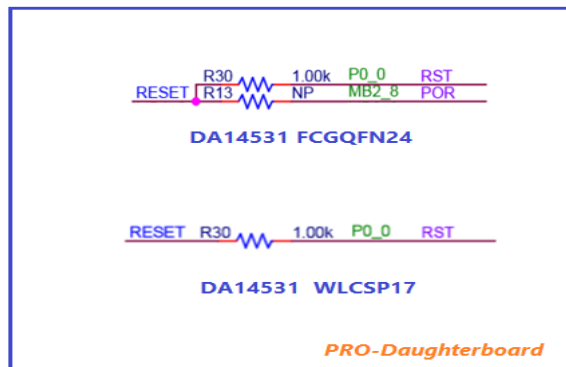

Figure 21: Reset Pin Assignment on PRO-DBs for FCGQFN24 and WLCSP17

5.3.2 JTAG

JTAG uses the Serial Wire Debug (SWD) protocol and consists of the SWDIO and SWCLK lines. Depending on the package of DA14531, the SWDIO signal is assigned to different pins (Table 5).

Table 5: Configuration Settings for JTAG In DA14531 DK Pro

Function		The Signals			Comments
		PRO-MB	DA14531 PRO-DB		
Enabled by Jumpers		J2	FCGQFN24	WLCSP17	
SW_CLK	J1:21-22 (Default)	SWCLK	P0_2	P0_2	
SW_DIO	J1:23-24 (Default)	SWDIO	P0_10	P0_5	

JTAG signals are also available on DA14531 PRO-DBs on header J4 (Figure 22).

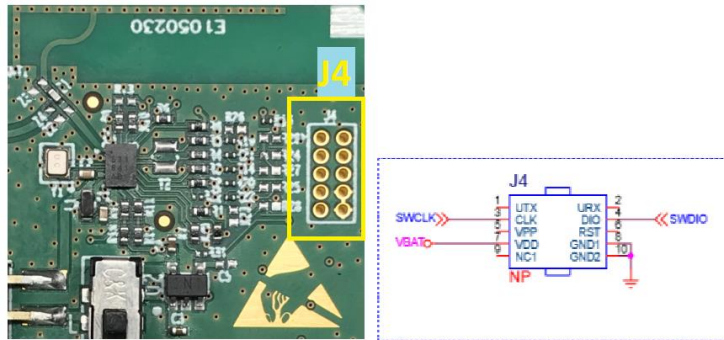

Figure 22: Optional Debug Port

5.3.3 SPI Data Flash (U2)

SPI data flash is enabled by default. The SPI data flash is the MX25R2035 from Macronix (2 Mbit) and located on DA14531 PRO-MB.

Ext-SPI slave mode is used to connect DA14531 to SPI data flash.

The flash is absolutely isolated from the rest of the circuit unless appropriate jumpers are. The configuration for SPI data flash is presented in Table 6.

Table 6: Configuration Settings for SPI Data Flash in DA14531 DK Pro

Function		The Signals			Comments
		PRO-MB	DA14531 PRO-DB		
Enabled by Jumpers		J2	FCGQFN24	WLCSP17	
MOSI	J1:3-4 (Default)	P0_6	P0_0	P0_0	
FCS	J1:7-8 (Default)	P0_3	P0_1	P0_1	
MISO	J1:9-10 (Default)	P0_5	P0_3	P0_3	
SCK	J1:5-6 (Default)	P0_0	P0_4	P0_4	
V_FL	J1:1-2 (Default)	V3	VH-	VH-	Flash Voltage. It is supplied with the voltage rail of VBAT_HIGH

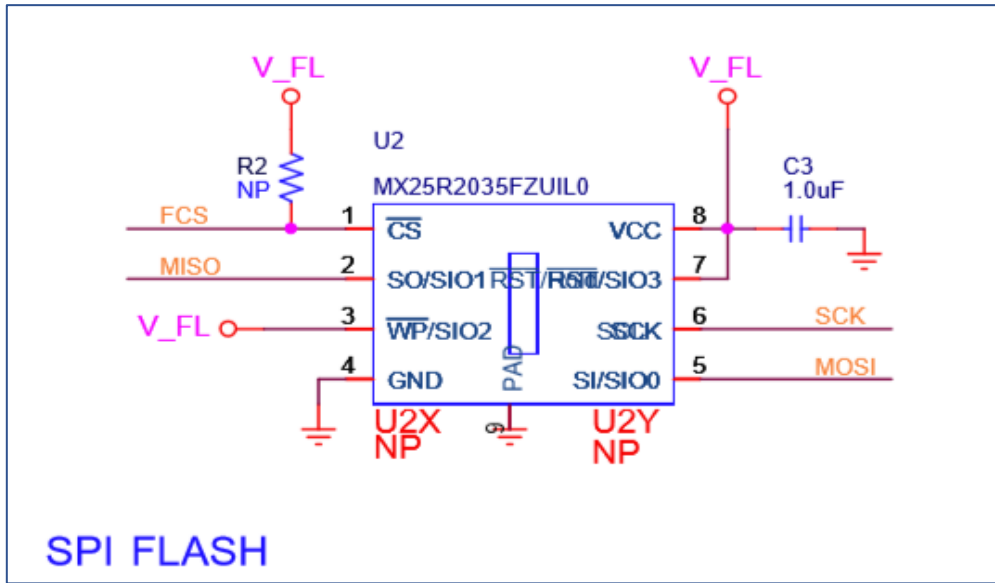

Figure 23: SPI Data Flash Circuit in DA14531 DK Pro

### 5.3.4 UART

In the DA14531 DK PRO, UART is not enabled by default. Three modes can be used: single-wire UART (section 0), 2-wire UART (section 5.3.4.2), or full UART (section 5.3.4.3). For the 2-wire or full UART, the SPI data flash must be disabled.

Any GPIO pin can be set as UART. In the DA14531 DK PRO, specific pins are used for UART signals (Table 7). Use short cables on DA14531 PRO-MB to bridge J2 pins (P2\_0 to P3\_1) and pins of J1 (odd pin-numbers).

Table 7: UART Signals Assignment in DA14531 DK PRO

Function		The signals			Comments
		PRO-MB	DA14531 PRO-DB		
		J2	FCGQFN24	WLCSP17	
UTX	2-wire or Full Transmit	P2_0	P0_0	P0_0	Signals reused for SPI Data Flash
URX	2-wire or Full UART Receive	P2_1	P0_1	P0_1	
UCTS	2-wire or Full UART Clear to Send	P2_3	P0_3	P0_3	
URTS	2-wire or Full UART Request To Send	P2_4	P0_4	P0_4	
RxTx	Single wire UART Receive and Transmit	P2_3		P0_3	
		P2_5	P0_5		

5.3.4.1 Single-wire UART

- DA14531-WLCSP17: use P0\_3 for single-wire UART. It is supported from SmartSnippet Toolbox. A wire bridge must be used on PRO-MB.
- DA14531-FCGQFN24: use P0\_5 for single-wire UART. it is supported from SmartSnippet Toolbox. There is no need for bridge wire (Table 8).

Table 8: Single-wire UART Pin Assignment

Function		The Signals		Comments
		PRO-MB	DA14531 PRO-DB	
Enabled by Jumper/Wire-Bridge		J2	FCGQFN24 WLCSP17	
RxTx	Jumper: J1: 19-20	P2_5	P0_5	No need to disable SPI Data Flash.
	Jumper: J10:1-J1:15			
	Jumper: J10:2-J1:17			
	wire: J1:19 to J2:24	P2_3	P0_3	In order not to conflict with MISO, disable SPI Data Flash. Remove jumpers: J1: 1-2/J1: 3-4/J1:5-6/J1:7-8/J1:9-10
	Jumper: J10:1-J1:15			
Jumper: J10:2-J1:17				

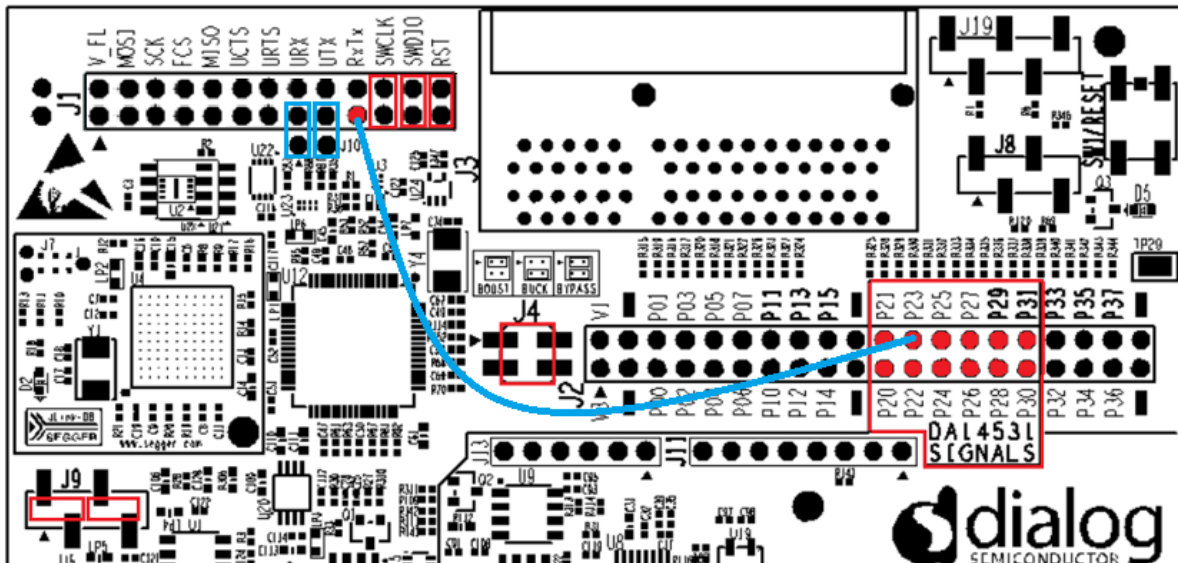

Figure 24: Single-wire UART for DA14531 WLCSP17 PRO-DB

5.3.4.2 2-wire UART Configuration

- UTX and URX signals are multiplexed with FCS (chip select) and MISO of SPI data bus
- Two wires are required to connect UTX and URX to DA14531 PRO-DBs
- Disable SPI data flash by removing jumpers on J1
- JTAG and Reset can be used

Table 9: 2-wire UART Pin Assignment

Function		The Signals			Comments
		PRO-MB	DA14531 PRO-DB		
Enabled by Wire-Bridge		J2	FCGQFN24	WLCSP17	
UTX	J1:17 to J2:21	P2_0	P0_0	P0_0	Remove jumper J1: 3-4
URX	J1:15 to J2:22	P2_1	P0_1	P0_1	Remove jumper J1: 7-8

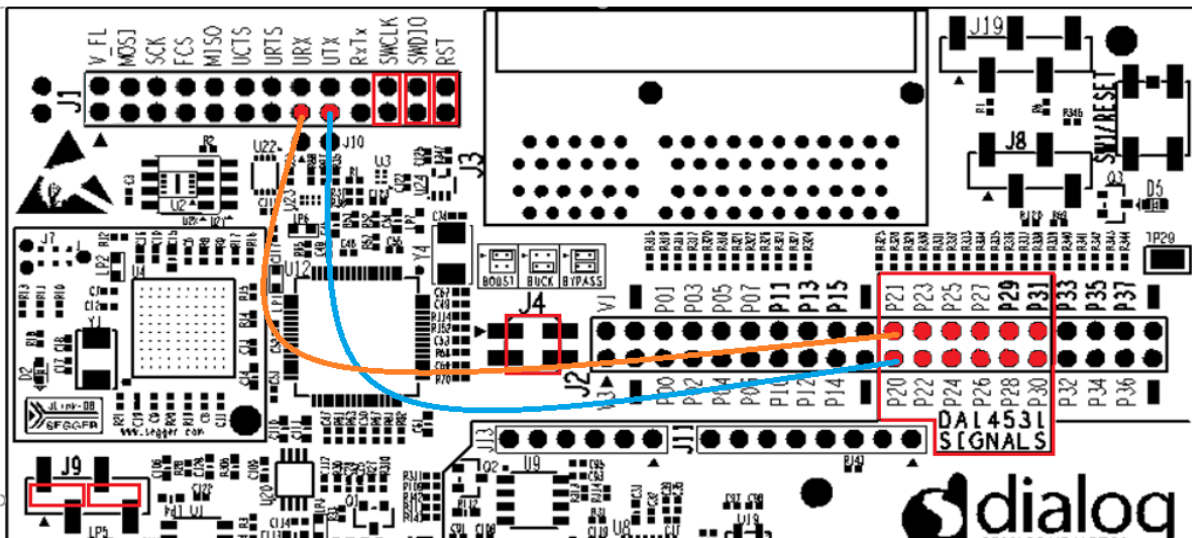

Figure 25: 2-wire UART Connectivity

5.3.4.3 Full UART (4-wire) Configuration

- UTX and URX as well as UCTS and URTS signals are multiplexed with FCS, MISO, MOSI, and SCK of the SPI data bus, respectively
- Four wires are required to connect UART signals to DA14531 PRO-DBs
- Disable SPI data flash by removing jumpers on J1
- JTAG and Reset can be used

Table 10: Full UART Pin Assignment

Function		The Signals			Comments
		PRO-MB	DA14531 PRO-DB		
Enabled by Wire-Bridge		J2	FCGQFN24	WLCSP17	
UTX	J1:17 to J2:21	P2_0	P0_0	P0_0	Remove jumper J1: 3-4
URX	J1:15 to J2:22	P2_1	P0_1	P0_1	Remove jumper J1: 7-8
UCTS	J1:11 to J2:24	P2_3	P0_3	P0_3	Remove jumper J1: 9-10
URTS	J1:13 to J2:25	P2_4	P0_4	P0_4	Remove jumper J1: 5-6

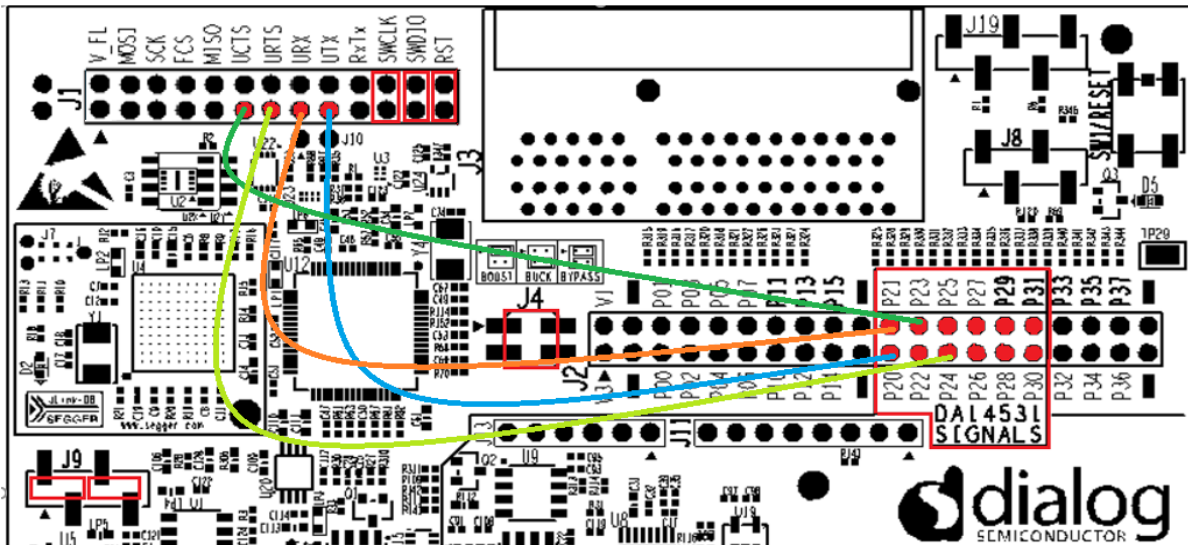

Figure 26: Full UART (4-wire) Connectivity

#### 5.3.5 Push Buttons

- There are two available push buttons, SW2 and SW3, on DA14531 PRO-MB
- Push buttons are available mainly for DA14531 FCGQFN24 PRO-DB
- SW3 is connected to SWDIO signal (P0\_10 for DA14531 FCGQFN24). Users must enable SW3 on software
- SW2 is assigned to P0\_11 of DA14531 FCGQFN24 (P3\_1 of PRO-MB)

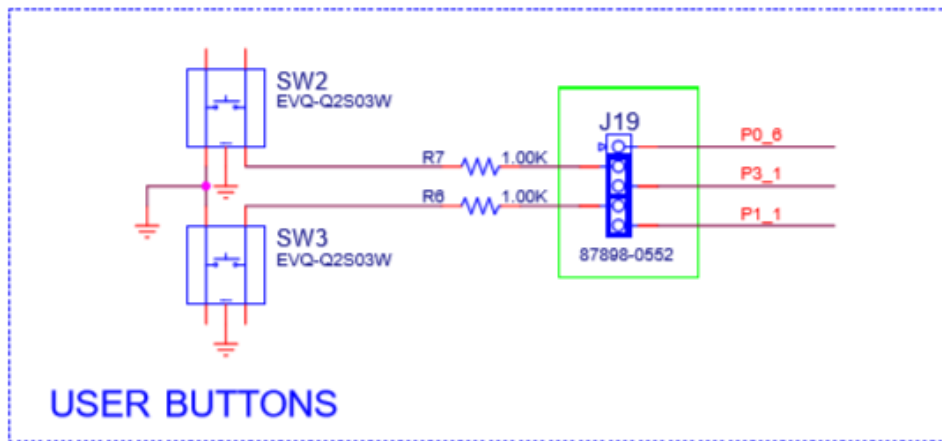

Figure 27: Miscellaneous Peripherals



Table 11: Configuration settings for push buttons

Function		PRO-MB	The Signals		Comments
			DA14531 PRO-DB		
Enabled by Jumpers		J2	FCGQFN24	WLCSP17	
SW2	J19:1-2	P0_6	P0_0	P0_0	Reused in Flash, Reset, UART, and mikroBUS. Before enabling the signal, ensure that there is no conflict on system operation.
	J19:2-3 (Default)	P3_1	P0_11		
SW3	J19:4-5	P1_1	P0_10		P0_10 is not available on DA14531 for this function.

5.3.6 User LED (D5) and C-Trig (Software Cursor)

The user LED (D5) and the software cursor trigger (C-trig) are available only for DA14531 FCGQFN24 PRO-DB. The user LED is enabled by default and it is driven from P0\_9 of DA14531 FCGQFN24 PRO-DB (P1\_0 of PRO\_MB). The C-Trig is used by the power profiler of SmartSnippet Toolbox to enable the software cursor. It is connected to P0\_11 of DA14531 FCGQFN24 PRO-DB through a 1 kΩ resistor.

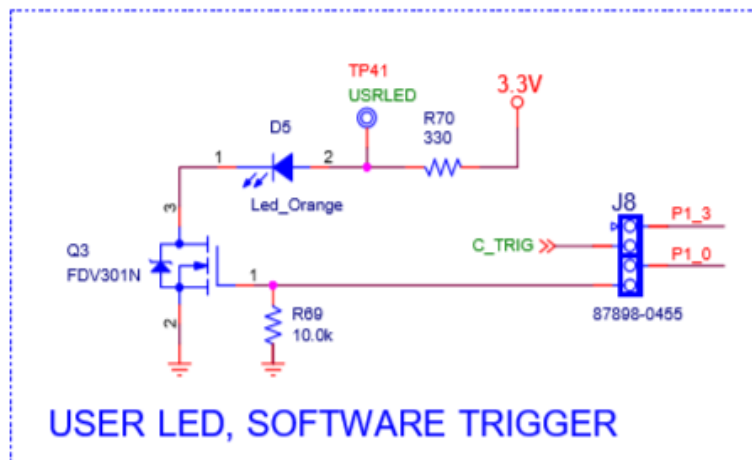

Figure 28: User LED and Software Trigger Circuit and Jumpers

Table 12: Configuration settings for miscellaneous peripherals

Function		PRO-MB	The Signals		Comments
			DA14531 PRO-DB		
Enabled by Jumpers		J2	FCGQFN24	WLCSP17	
LED	J8:3-4 (Default)	P1_0	P0_9	NA	
C_TRIG	J8:1-2 (Default)	P1_3	P0_11	NA	Also assigned to SW2. In order not to disturb C-TRIG operation, remove the jumper from J18:2-3.

#### 5.3.7 mikroBUS 2 Interface

- mikroBUS 2 is used for DA14531 PRO-DB
- Two female headers (8 position 0.100", through hole, socket type) must be mounted on J17 and J18
- DA14531 FCGQFN24 PRO-DB is suitable for mikroBUS operation due to its available pins
- SPI data bus is shared with SPI data flash or UART

**Table 13: mikroBUS 2 Signals**

Function		The Signals			Comments
		PRO-MB	DA14531 PRO-DB		
Available on Headers		J2	FCGQFN24	WLCSP17	
MOSI_2	J17:5	P2_0	P0_0	P0_0	Also used from SPI Data Flash or UART.
SCL_2	J18:5	P2_2	P0_2	P0_2	
MISO_2	J17:6	P2_3	P0_3	P0_3	
SCK_2	J17:4	P2_4	P0_4	P0_4	
TX_2	J18:4	P2_5	P0_5	P0_5	Used for SWDIO of WLCSP17. Used for single-wire UART of FCGQFN24.
RX_2	J18:3	P2_6	P0_6		
CS_2	J17:3	P2_7	P0_7		
SDA_2	J18:6	P2_8	P0_8		
PWM_2	J18:1	P2_9	P0_9		
BRSTn	J17:2	P3_0			It is not enabled. BRSTn can be connected to P0_10 (SWDIO) by mounting R11 on FCGQFN24 PRO-DB.
V3	J17:7		V <sub>BAT_HIGH</sub>		The same voltage rail applied to V <sub>BAT_HIGH</sub> pin of DA14531 SoC.
V5	J18:7				Voltage provided from USB port, V <sub>BUS_HUB</sub> = 5 V through R305.

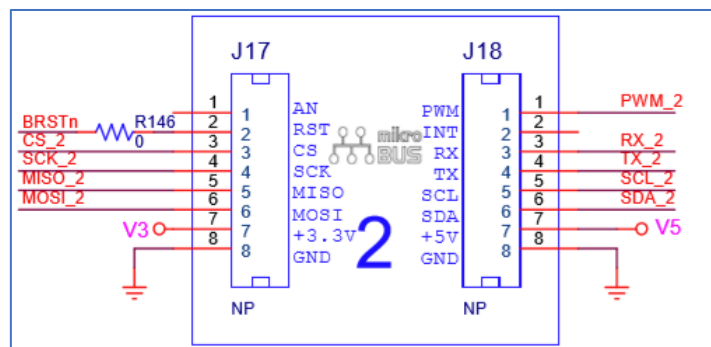

**Figure 29: MikroBus 2 Circuit**

**5.3.8 Arduino Interface**

Four female headers (0.100", through hole, socket type) must be mounted on J11, J12, J13, and J14.

**Table 14: Arduino Signals**

Function		The Signals			Comments
		PRO-MB	DA14531 PRO-DB		
Available on Headers		J2	FCGQFN24	WLCSP17	
SCK_1	J13:4	P0_0	P0_4	P0_4	Multiplexed with SPI, UART, and other Arduino Interface signals.
A2	J13:3	P0_3	P0_1	P0_1	
SDA_1	J12:1	P0_4	P0_0	P0_0	
SCL_1	J12:2	P0_7	P0_4	P0_4	
PWM_1	J12:3	P1_0	P0_9		Multiplexed with User LED. Can remove J8:3-4.
RX_1	J13:6	P1_1	P0_10		Multiplexed with SWDIO of DA14531 FCGQFN24 PRO-DB. It must be enabled in software.
AN_2	J12:9	P2_1	P0_1	P0_1	Multiplexed with SPI, UART, and other Arduino Interface signals.
SCL_2	J12:10	P2_2	P0_2	P0_2	
TX_2	J12:4	P2_5	P0_5	P0_5	Used for SWDIO of WLCSP17. Used for single-wire UART of FCGQFN24.
RX_2	J12:5	P2_6	P0_6		
CS_2	J12:6	P2_7	P0_7		
SDA_2	J14:1	P2_8	P0_8		
BRSTn	J11:3	P3_0			It is not enabled.
INT_2	J14-2	P3_1	P0_11		
V3	J11:4		VBAT_HIGH		The same voltage rail applied to VBAT_HIGH pin of DA14531 SoC.
V5	J11:5				VBUS_HUB voltage provided from USB port.

## 6 How to Configure Power of DA14531 DK PRO

On DA14531 DK PRO, users can:

- Set DA14531 SoC on Buck, Boost, or Bypass mode (applied to J4 on PRO-MB), [Table 15](#)
- Provide four different voltage rails to DA14531 SoC, that is, 1.1 V, 1.8 V, 3.0 V, and 3.3 V (default) (applied on J5 on PRO-MB), [Table 15](#)

Jumper settings of J9 enables the current sensing circuit, [Table 16](#). Jumpers are applied by default.

On DA14531 PRO DBs (WLCSP17 and FCGQFN24), users must set SW1 to buck position permanently. The power circuit consisting of U2 and SW1 on PRO-DBs is not needed.

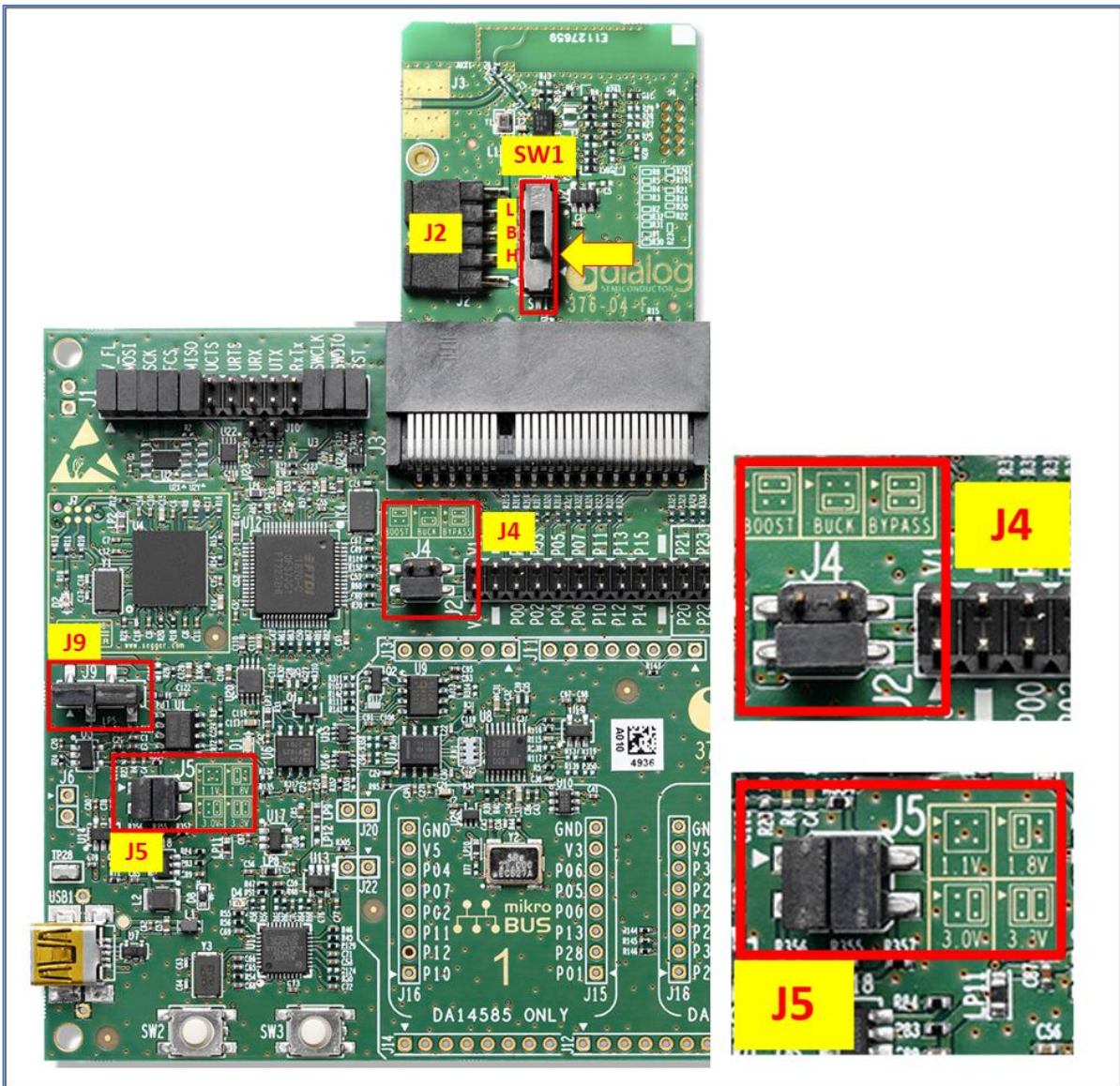

Figure 30: DA14531 PRO-DB Configuration and DA14531 PRO-MB Jumpers

## DA14531 Development Kit Pro Hardware User Manual

**Table 15: DA14531 DCDC Configuration and Input Voltage**

Board	Configuration	Setting	Comments
PRO-MB		J9:1-2 J9:3-4	Enabling the current sensing circuit of PRO-MB
	1.1 V	J5: no jumper	Voltage levels of $V_{LDO}$ $V_{LDO}$ generates V1 and V3
	1.8 V	J5: 1-3	
	3.0 V	J5: 2-4	
	3.3 V (Default)	J5: 1-3 J5: 2-4	
	Boost	J4:1-2	$V_{BAT\_LOW}$ supplied by V1, enabling Boost mode
	Buck (Default)	J4:3-4	$V_{BAT\_HIGH}$ supplied by V3, enabling Buck mode
Bypass	J4:1-2 J4:3-4	$V_{BAT\_HIGH}$ and $V_{BAT\_LOW}$ are supplied from V3 and V1, respectively, enabling bypass mode	
DA14531 PRO-DB		J1:1-2 J1:4-5	jumpers applied
	Buck Mode	SW1: H	

**Table 16: Jumper Settings for J9**

Jumper on J9	Function	Comments
J9: 1-2 J9: 3-4	$V_{LDO}$ supplies PRO-DB Current sensing circuit enabled	See <a href="#">Figure 16</a>
J9:2-3	$V_{LDO}$ supplies PRO-DB Current sensing circuit is bypassed	See <a href="#">Figure 16</a>
J9: 3-4	BT1 supplies PRO-DB Current sensing circuit enabled	BT1 must be mounted See <a href="#">Figure 16</a>

**Example:** to provide 3.0 V in buck mode, proceed with the following actions:

- On DA14531 PRO-MB, apply jumpers to J5:2-4 and J4:3-4.
- On DA14531 PRO-DB, set SW1 to the H position (buck mode) and apply jumpers to J2:1-2 and J2:4-5

**NOTE**

Loss of communication between PC and DA14531 DK PRO may occur when the power configuration for DA14531 DK PRO is changed. If it happens, power cycle the DA14531 DK PRO.

## 6.1 Battery Operation

On DA14531 DK PRO, the DA14531 system can be supplied from a 3 V coin cell battery, type CR2032.

A coin cell battery can be applied to either a PRO-MB or a DA14531 PRO-DB.

DA14531 Development Kit Pro Hardware User Manual

When battery is mounted, power source from PRO-MB must be removed.

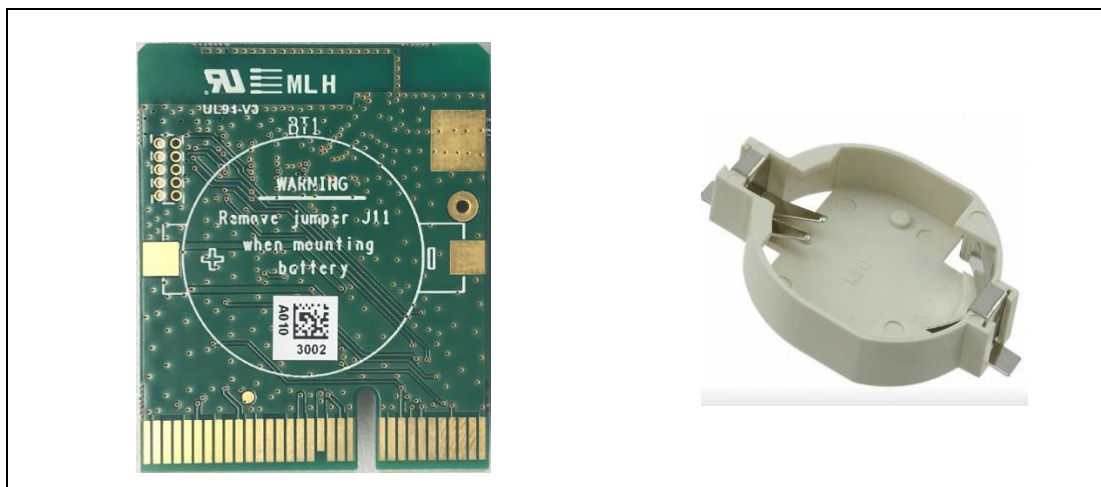

Figure 31: BT1 Position (Left). Battery Holder, BC2032-F1, to Be Soldered (Right)

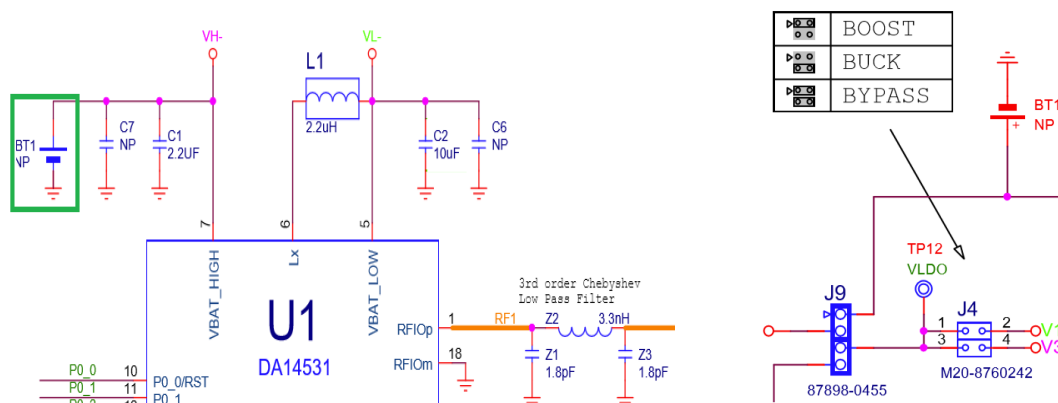

Figure 32: DA14531 PRO-DB Schematic (Left). DA14531 PRO-MB, Header J4 Settings (Right)

6.1.1 Enabling Coin Cell Battery on DA14531 PRO-DB

To enable a coin cell battery on DA14531 PRO-DB, before powering on the DA14531 DK PRO, make the following changes:

- On DA14531 PRO-DB:
  - Solder the battery socket on the solder side (BT1) by using BC2032-F1 (see Figure 31)
  - Insert a CR2032 coin cell battery
- On PRO-MB (see Figure 32, right)
  - Remove all jumpers from J4
  - Ensure that no battery is inserted in BT1

6.1.2 Enabling Coin Cell Battery on PRO-MB

To enable a coin cell battery on DA14531 PRO-MB, before powering on the DA14531 DK PRO, make the following changes:

- On DA14531 PRO-DB: ensure that no battery is inserted in BT1 (see Figure 31)
- On PRO-MB (see Figure 32, right):
  - Remove the jumper on J9:1-2 and apply a jumper on J9:3-4

### DA14531 Development Kit Pro Hardware User Manual

- Solder the battery socket on the solder side (BT1) by using BU2032SM-BT-GTR (see Figure 33)
- Insert a CR2032 coin cell battery

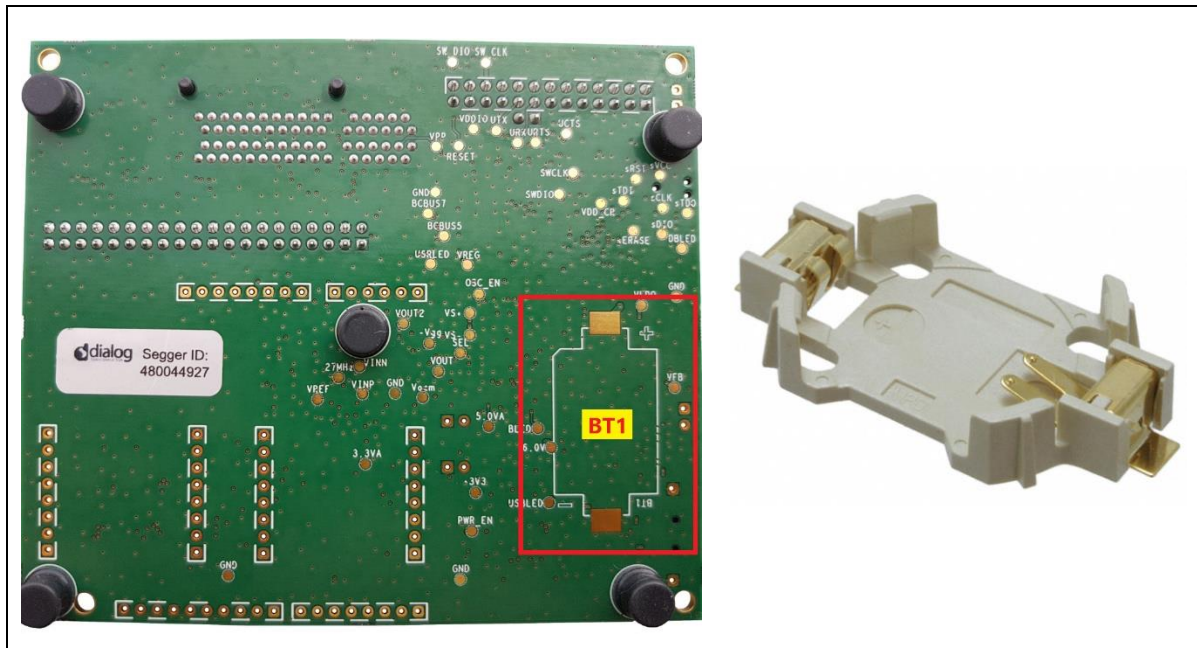

**Figure 33: BT1 Position on PRO-MB (Left). Battery Holder, BU2032SM-BT-GTR, to Be Soldered (Right)**

## 7 First Steps with DA14531 DK PRO

The DA14531 DK PRO comes in with a pre-defined default configuration. However, due to the low GPIO pin count, several functions are multiplexed and can be enabled as needed via jumpers. In the default configuration, the DA14531 DK PRO supports the following functions:

- DA14531-FCGQFN24: reset, JTAG and SPI data flash. Single-wire UART is also supported with proper jumper settings.
- DA14531-WLCSP17: reset, JTAG and SPI data flash

In the following sections, the supported features are detailed for each daughterboard.

### 7.1 Configuration of DA14531 DK PRO with a DA14531 FCGQFN24 PRO-DB

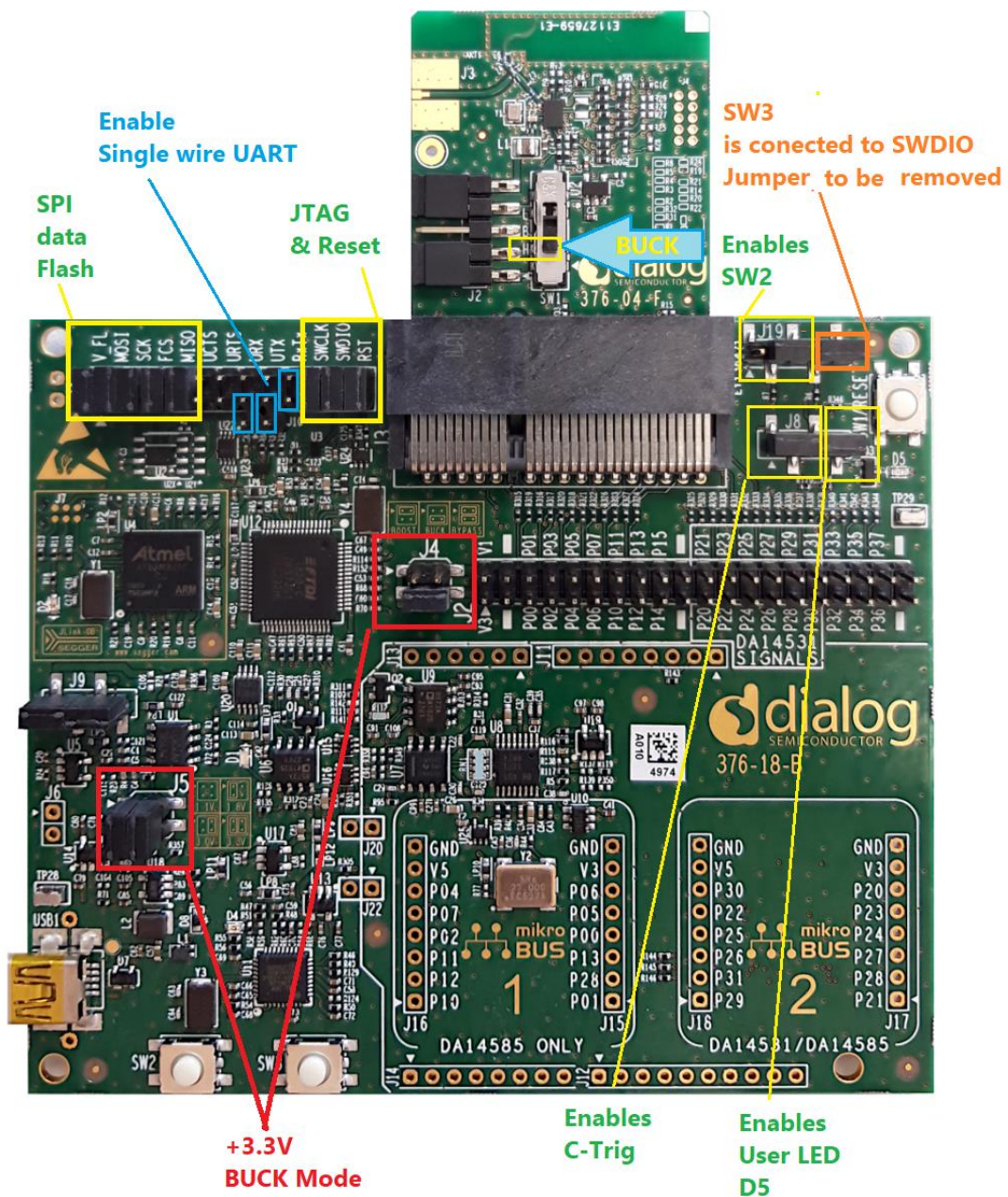

Figure 34: Default Setup of the DA14531 DK PRO with DA14531 FCGQFN24 PRO-DB



---

## DA14531 Development Kit Pro Hardware User Manual

---

In the DA14531 FCGQFN24 PRO-DB, the push button SW1 **must be placed** in the H position for BUCK mode (Figure 34).

The DA14531 PRO-MB is delivered in a default configuration (Figure 34) which:

- Enables the on-board SPI data flash
- Enables the JTAG (SWD) debugging interface
- Enables single-wire UART by adding jumpers on J10:1 to J1:15 and J10:2 to J15:17 (marked by blue)
- Enables the user push button SW2 and user LED D5
- Connects SW3 to SWDIO (JTAG interface) by removing the jumper
- Enables C-Trig. Please note that it is connected to the signal (P0\_11) which drives SW2. If both functionalities are required, assign one of the two functions to a free GPIO and wire accordingly.
- Allows the DA14531 to be reset (over JTAG or by using the SW1 push button)
- Sets DA14531 DCDC converter to Buck mode to provide 3.3 V
- Enables the current sensing circuit

7.2 Configuration of DA14531 DK PRO with a DA14531 WLCSP17 PRO-DB

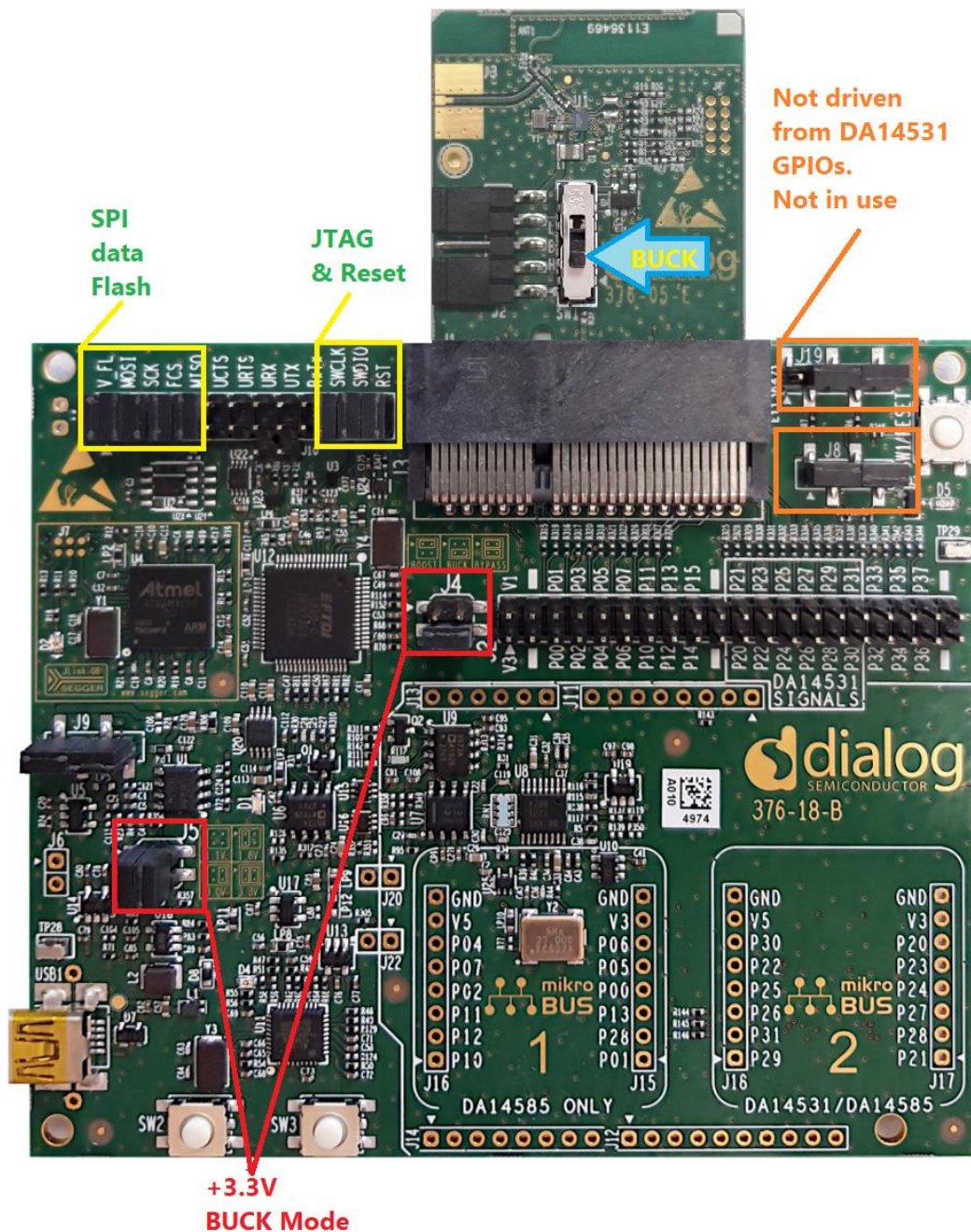

Figure 35: Default Setup of the DA14531 DK PRO with a DA14531 WLCSP17 PRO-DB

In the DA14531 WLCSP17 PRO-DB, the push button SW1 **must be placed** in the H position for BUCK mode (Figure 35).

The DA14531 PRO-MB is delivered in a default configuration (Figure 35) which:

- Enables the on-board SPI data flash
- Enables the JTAG (SWD) debugging interface
- Allows the DA14531 to be reset (over JTAG or by using the SW1 push button)
- Sets DA14531 DCDC converter to Buck mode to provide 3.3 V
- Enables the current sensing circuit

## 8 Current Measurements

Current drawn from the DA14531 PRO-DB can be measured with a good accuracy by using the current sensing circuit and the power profiler of Dialog’s SmartSnippets Toolbox.

In this section, the current measurement circuit as well as the setup and the measurements of the power profiler are described, and the measurement accuracy is presented.

### 8.1 Current Measurement Circuit of PRO-MB

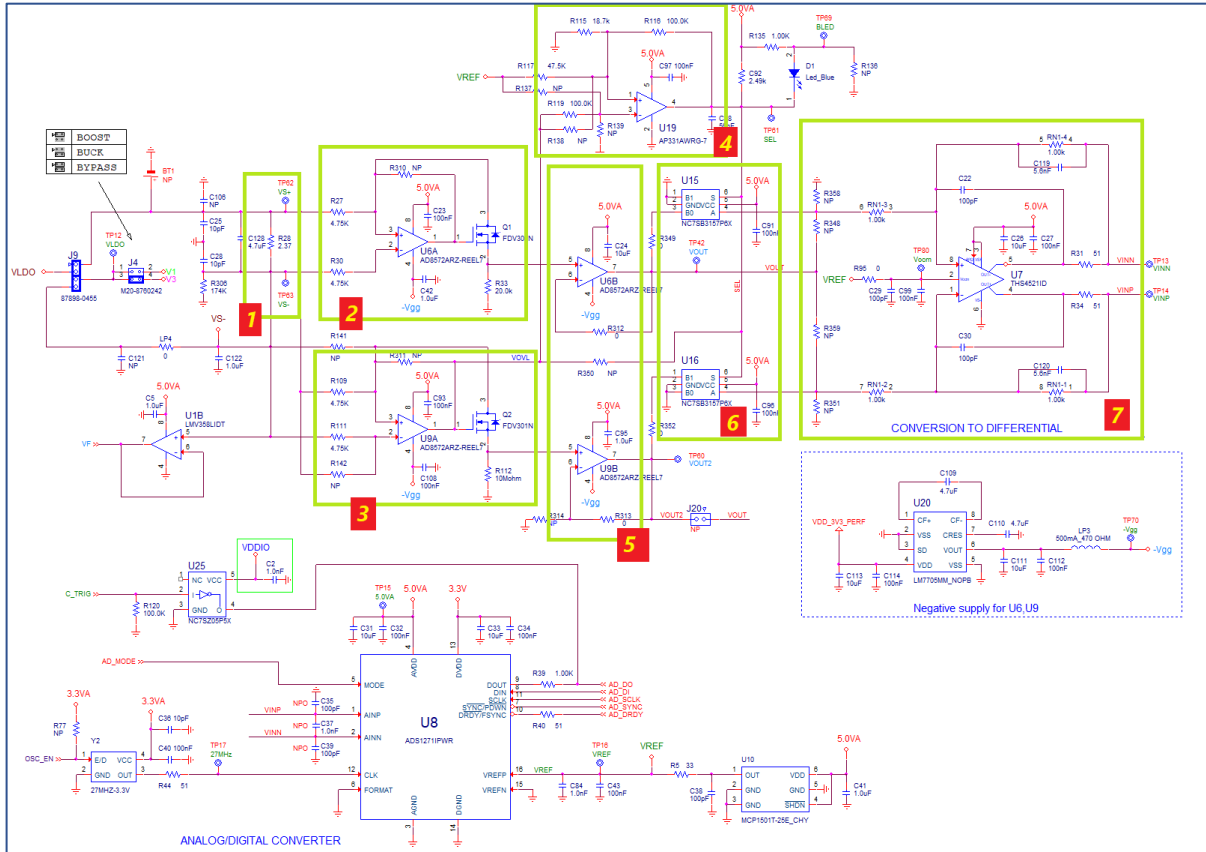

Figure 36: Current Measurement Circuit of DA14531 PRO-MB

Current measurement circuit is a section of the PRO-MB. The input to the circuit is the voltage across the sense resistor (R28). The output is the differential pair VINP, VINN which are connected to the inputs of the A/D converter.

The functional blocks of the current measurement circuit include:

- Sense resistor R28 (2.37 Ω)
- High scale C/V converter (Gain: 9.98 V/mA)
- Low scale C/V converter (Gain: 4989 V/mA)
- High/Low comparator: switches to high scale above ~300 μA and back to low scale below ~250 μA (with hysteresis)
- Voltage buffers. The V<sub>SS</sub> pin gets a -228 mV rail to allow the output to reach true zero
- Analog multiplexers: the low scale output is presented to the A/D converter with a negative polarity
- Single-ended to differential converter: it converts the ground referenced input to a differential pair aligned with the mid-scale reference voltage (V<sub>REF</sub> = 2.5 V) and a gain of ±0.5

## DA14531 Development Kit Pro Hardware User Manual

The differential amplifier outputs are connected to the ADC input. The digitally converted current samples are sent to PC through the UART-to-USB IC (U12). Finally, the measured current is presented to the PC converter and displayed in the power profiler of SmartSnippet Toolbox.



Figure 37: Current Measurement Presented in Power Profiler of SmartSnippets Toolbox

### 8.2 Power Profiler of Smartsnippet Toolbox

Dialog's SmartSnippets Toolbox can be invoked from within the SmartSnippets Studio Welcome page.

Alternately, it can run directly from the start menu under the section "Dialog SmartSnippets Studio vx.x.xx\Dialog SmartSnippets Toolbox for SmartSnippets Studio vx.x.xx".

Upon opening, the application starts with the settings/interface options page. An existing entry can be selected from the list, or a new configuration can be created by pressing the "New" button (Figure 38).

At this point, to change the hardware setup, for example, to plug in another board, by pressing the "Refresh" button (Figure 38), the list of available ports will be updated.

To select the chip version, when the "Detect" button (Figure 38) is pressed, the tool identifies the exact part number of the SoC on the target board

For power measurements, users need to select an interface that allows the PC software (SmartSnippets Toolbox) to communicate with the A/D converter through the correct SPI port (which is camouflaged in the PC as a plain UART part. In Figure 38, the selected SPI port is COM18).

For power measurement, the "UART/SPI" option in Figure 38 is preferred, because JTAG is used for downloading code from the IDE and debugging. The "Hybrid" option can also be used. But power measurements are not feasible in the "UART-only" or "JTAG" option.

DA14531 Development Kit Pro Hardware User Manual

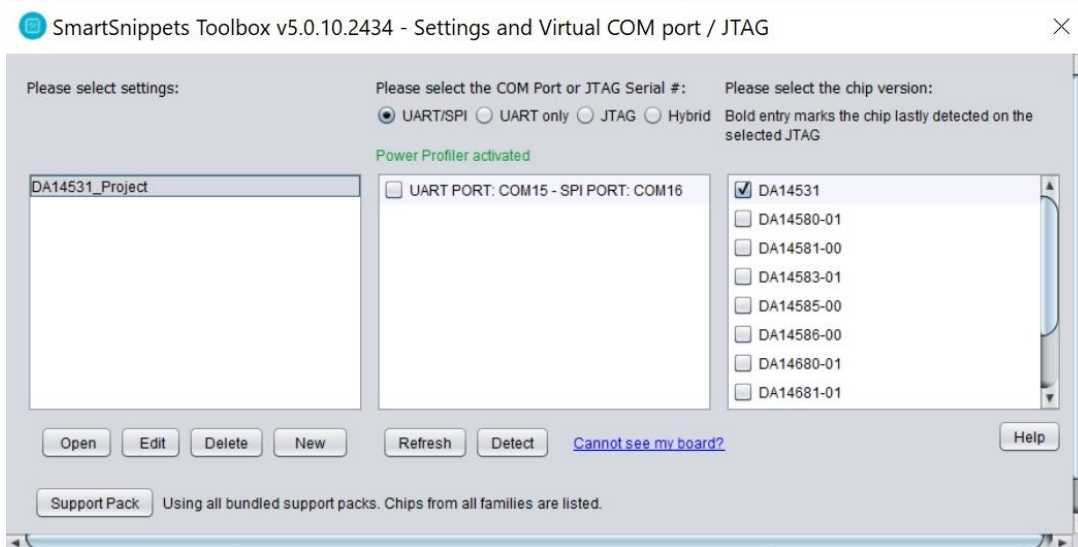

Figure 38: SmartSnippets Toolbox Configuration

In “Hybrid” mode (Figure 39), the selection box automatically lists the only valid SPI/COM ports and debugger serial numbers.

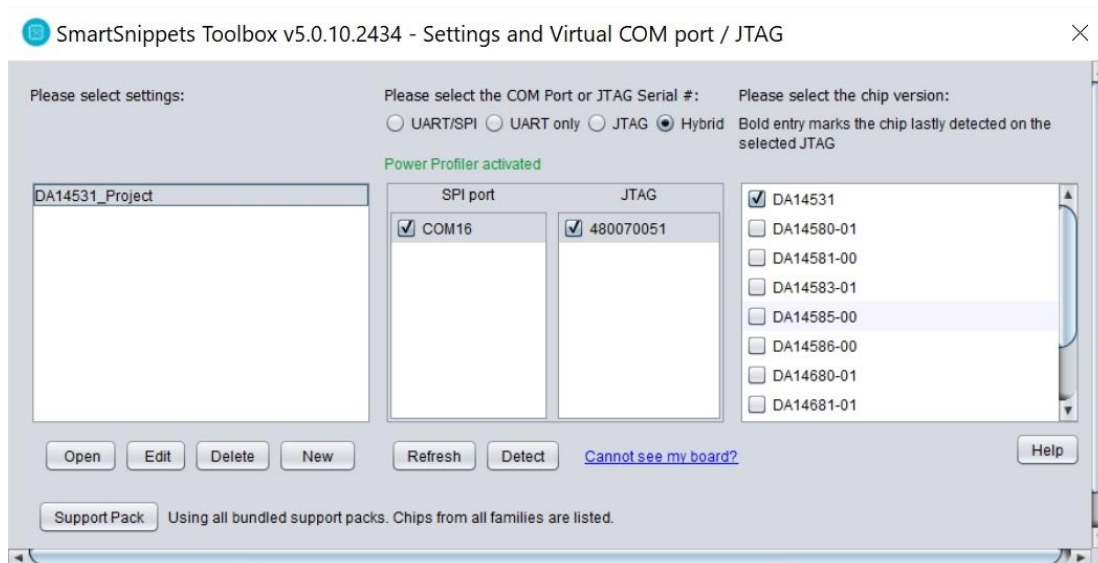

Figure 39: Hybrid Configuration

### 8.3 Power Profiler Setup

After selecting the proper option (UART/SPI or Hybrid) in Figure 38, press “Open” and the main window of the Power Profiler application in SmartSnippets Toolbox will pop up (Figure 40). Press “Config” button in the bottom right and check if everything is configured correctly (Figure 41).

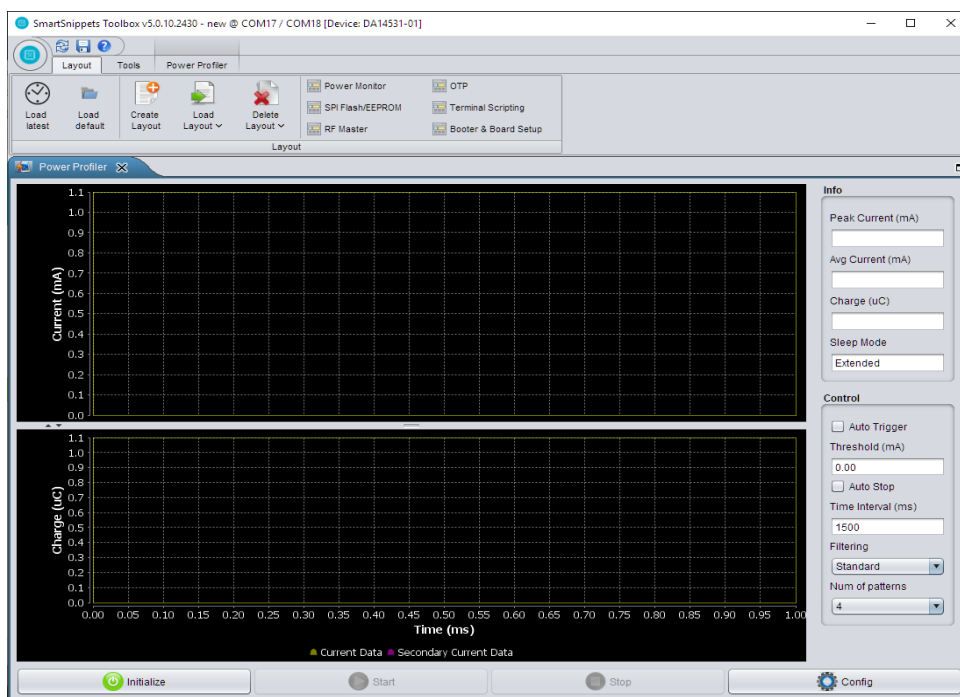

Figure 40: Power Profiler of SmartSnippets Toolbox Main Window

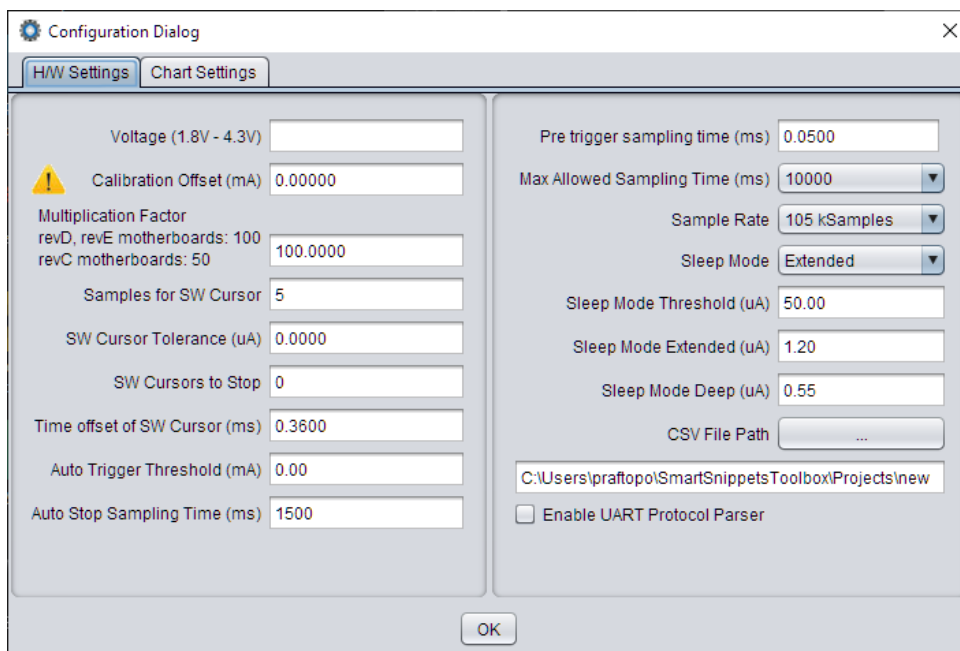

Figure 41: Power Profiler Configuration

In a new profile, the “**Voltage**” box in the “**H/W Settings**” is typically empty and the “**Calibration Offset**” is zero. Apply the correct voltage as configured in the PRO-MB LDO (typically, it is 3.3 V). The calibration offset (mA) will be filled automatically with a calculated value. This value is good enough for measuring with  $\pm 2\%$  accuracy, so in most cases we can leave it as is.

Check the multiplication factor. For DA14531 it should be **100**.

Optionally, set a max scale for the waveform window, because typically there are large peaks on wake-up from sleep (charging capacitors), so the useful part of the signal is compressed to a very small area. To set a max scale for the waveform window, access the “**Chart Settings**” tab (Figure 42) and set the max scale of “**Current1**” to 10 mA. Note that this does not affect in any way the

DA14531 Development Kit Pro Hardware User Manual

accuracy of measurement. It only zooms-in the waveform that is presented on the viewer window. Press “OK” and return to the measurement window.

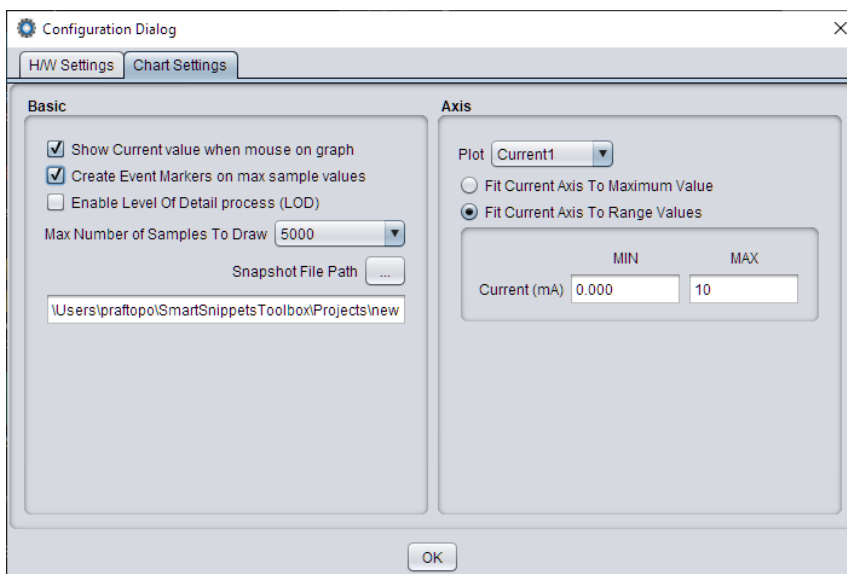

Figure 42: Power Profiler Chart Settings

8.4 Measurements

In the measurement window (Figure 43), press “Initialize” on the bottom left (this step is only needed at the first communication with the A/D converter) and then press “Start”.

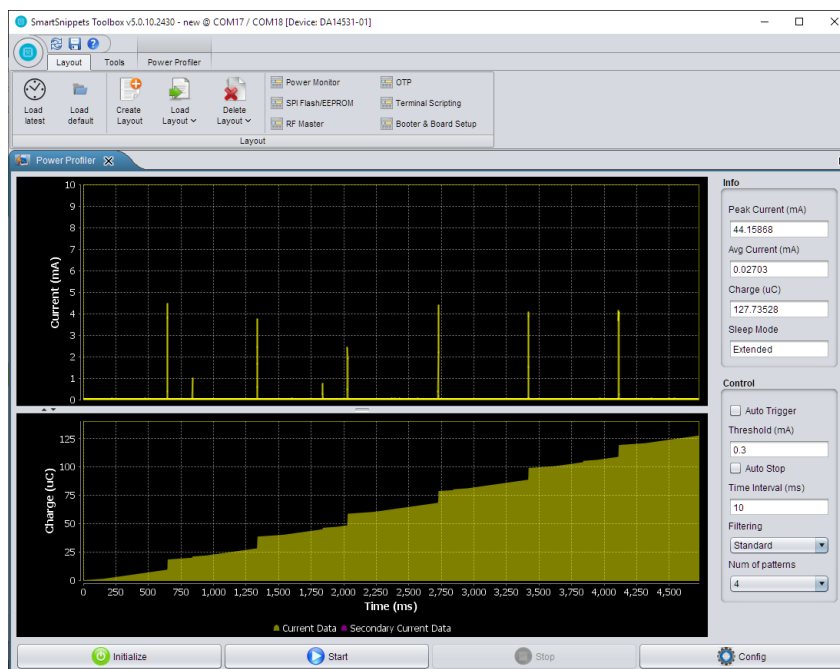

Figure 43: Free Running Capture

A triggered capture can be used for acquiring a single waveform (Figure 44).

DA14531 Development Kit Pro Hardware User Manual



Figure 44: Triggered Capture

Figure 45 shows a combination of the main Current1/Oscilloscope. This option can be selected from the “Power Profiler” tab. The top window presents the free running waveform, while the bottom window uses the trigger and time interval values to capture and print up to 10 of the most recent waveforms in an oscilloscope fashion. Note that the “Auto Trigger” and “Auto Stop” checkboxes under “Control” on the lower right-hand side must remain unchecked.

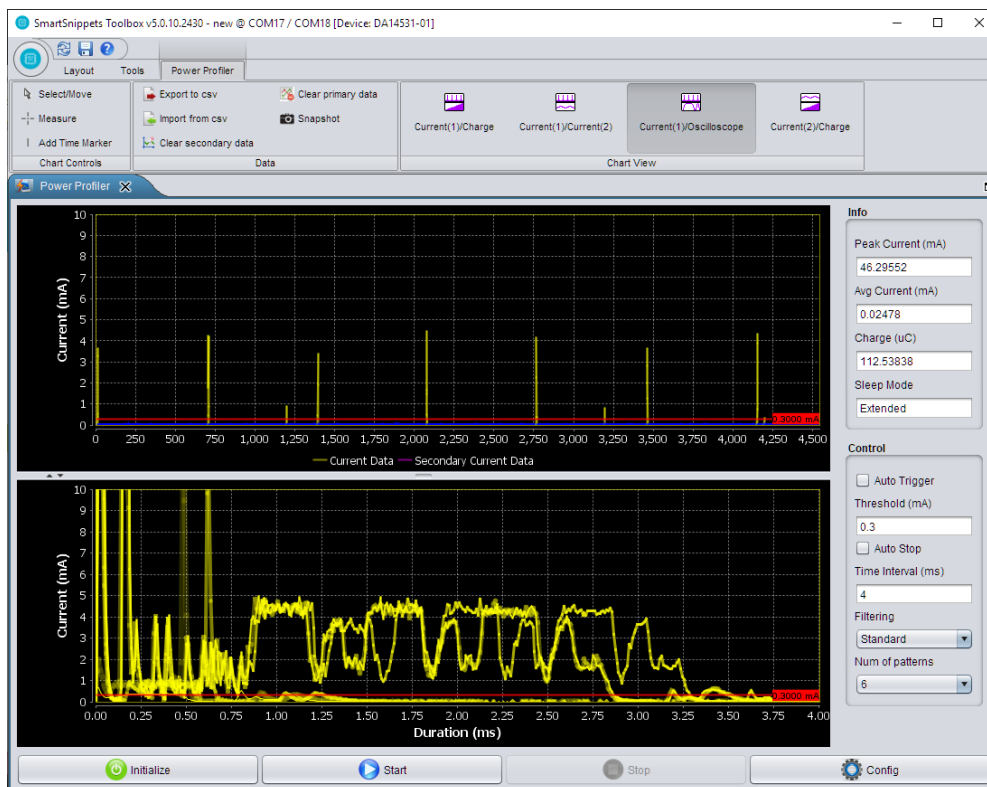

Figure 45: Oscilloscope Option



DA14531 Development Kit Pro Hardware User Manual

### 8.5 Power Profiler Software Cursors

Users can insert a vertical cursor (SW cursor) in the Power Profiler display by toggling C-Trig (mapped to P0\_11 of DA14531) in the SW running on the ARM Cortex M0+ CPU.

The SW cursor provides an accurate correlation between the SW and the power profile of the system in real time. The vertical line is not movable on the display window.

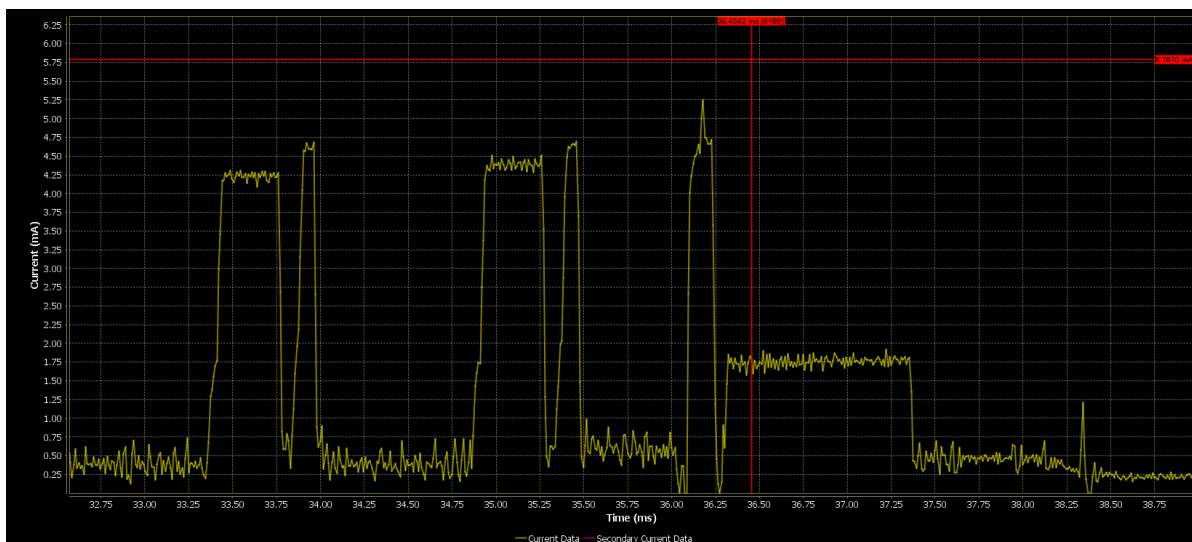

Figure 46: Power Profiler Software Cursors

### 8.6 Manual Calibration

For an ultimate measurement accuracy, it is necessary to perform a manual calibration by following the step below:

1. Remove the daughter board, that is, the load, by physically disconnecting the PRO-DB from the motherboard or temporarily removing the jumper from the connector J4.
2. In the main window of the Power Profiler, press **Config** and temporarily set the calibration offset to zero (Figure 47).

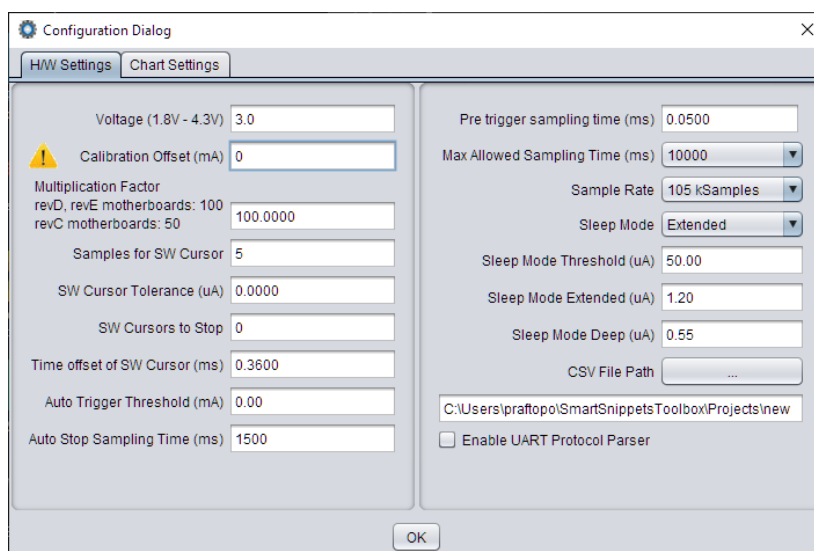

Figure 47: Setting Offset to Zero

DA14531 Development Kit Pro Hardware User Manual

- Run a free running capture for a few seconds and note down the number in the “**Avg Current (mA)**” box (Figure 48). Note that the last digits of the number keep changing slowly due to temperature drift. It is important to periodically execute the calibration steps.

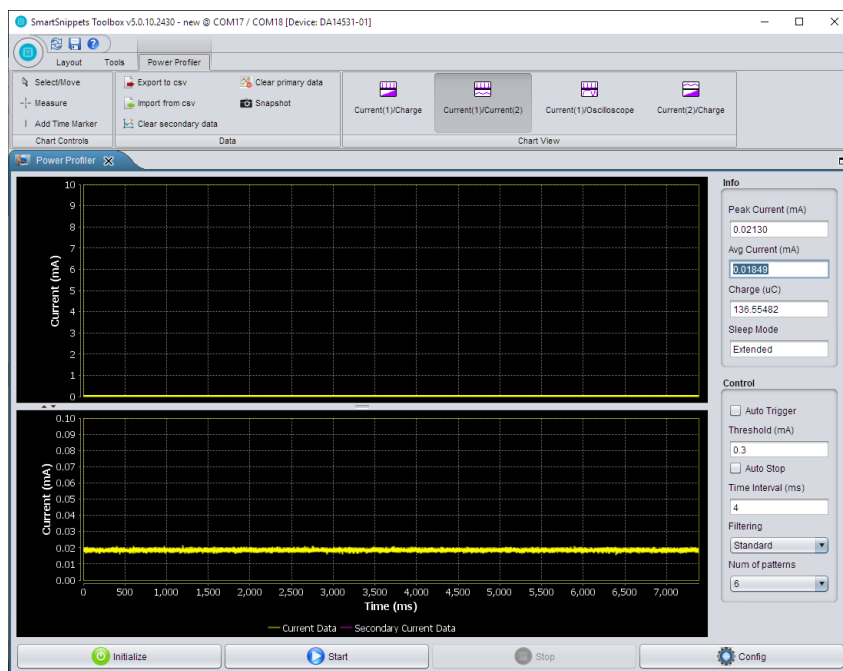

Figure 48: Measuring Offset

- Finally, put this average value with a negative sign in the “**Calibration Offset (mA)**” box. CTRL-C and CTRL-V also works.

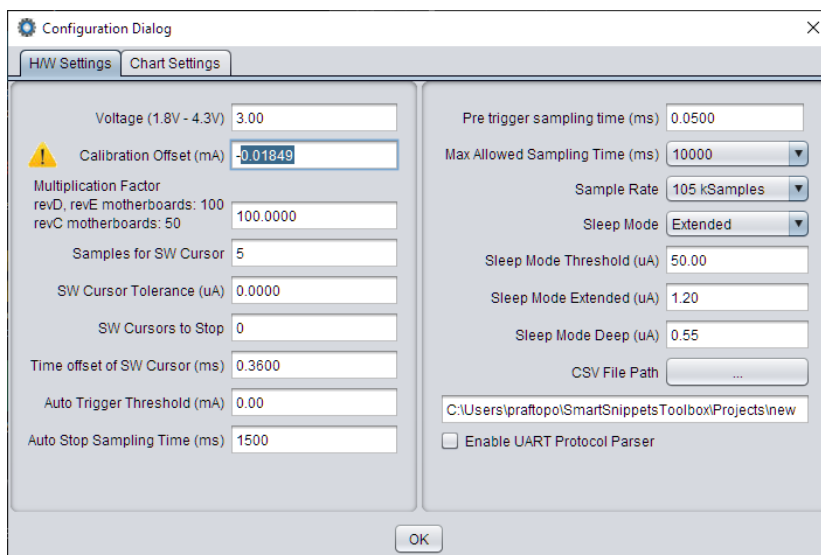

Figure 49: Setting Calibration Offset

- Re-insert the daughterboard or restore the jumper removed from J4 in the previous step.

**NOTE**

Please notice that the value in the **Voltage** box is 3 V. This is a typical value used across the industry for comparing BLE power measurements. Therefore, the power configuration on DA14531 PRO-MB must be updated accordingly (J5: 2-4).

DA14531 Development Kit Pro Hardware User Manual

8.7 Accuracy of Current Measurement Circuit

The measuring range of the current measurement circuit in DA14531 PRO-MB is 1  $\mu\text{A}$  to 240 mA. The circuit accuracy is measured by applying a constant current, monitoring the output with the SmartSnippets Toolbox, and compare the outcome.

In general, the inaccuracy presented in the current measurement circuit is less than 5% (practically less than 2%) in most of the current range. There are two areas where the inaccuracy is of the order of 10%, that is, from 1  $\mu\text{A}$  to 10  $\mu\text{A}$  and from 100  $\mu\text{A}$  to 300  $\mu\text{A}$  (Table 17).

Table 17: Accuracy of the Current Measurement Circuit

Current Range	Inaccuracy (%)
1 $\mu\text{A}$ to 10 $\mu\text{A}$	<13%
10 $\mu\text{A}$ to 100 $\mu\text{A}$	<5%
100 $\mu\text{A}$ to 300 $\mu\text{A}$	<10%
300 $\mu\text{A}$ to 240 mA	<5%

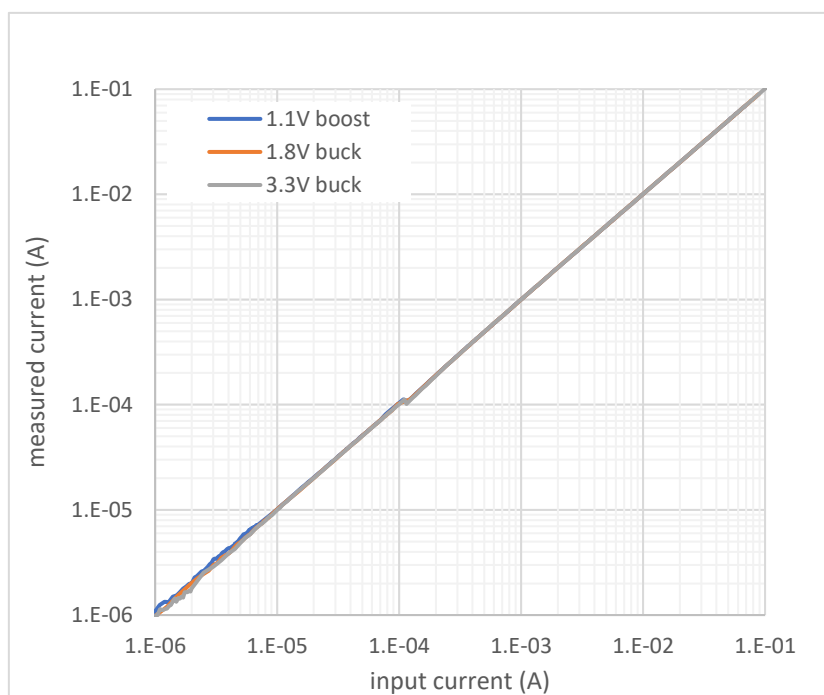

Figure 50: Current Measurement Circuit Response, Indicative Graph

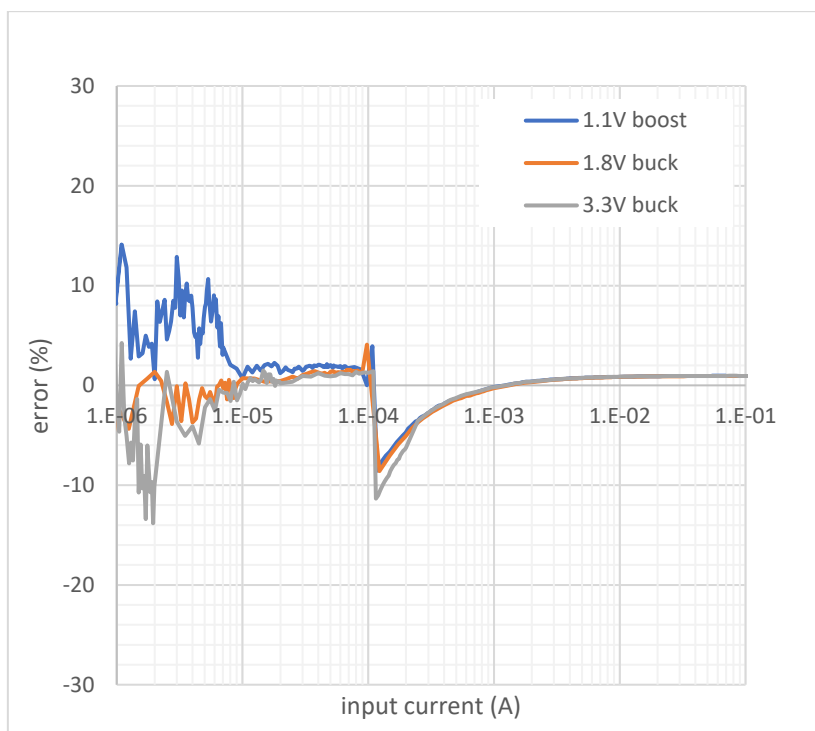

Figure 51: Current Measurement Circuit Inaccuracy, Indicative Graph

## 9 Known Issues

### 9.1 Switching Transient Artifacts of Current Measurement Circuit

When the current measurement circuit changes scale, it presents some small or large voltage step on the A/D converter inputs. An ideal converter (infinite bandwidth) would produce a single spike at the point of switching. But since the converter is not ideal, it produces a ringing like waveform (Figure 52).

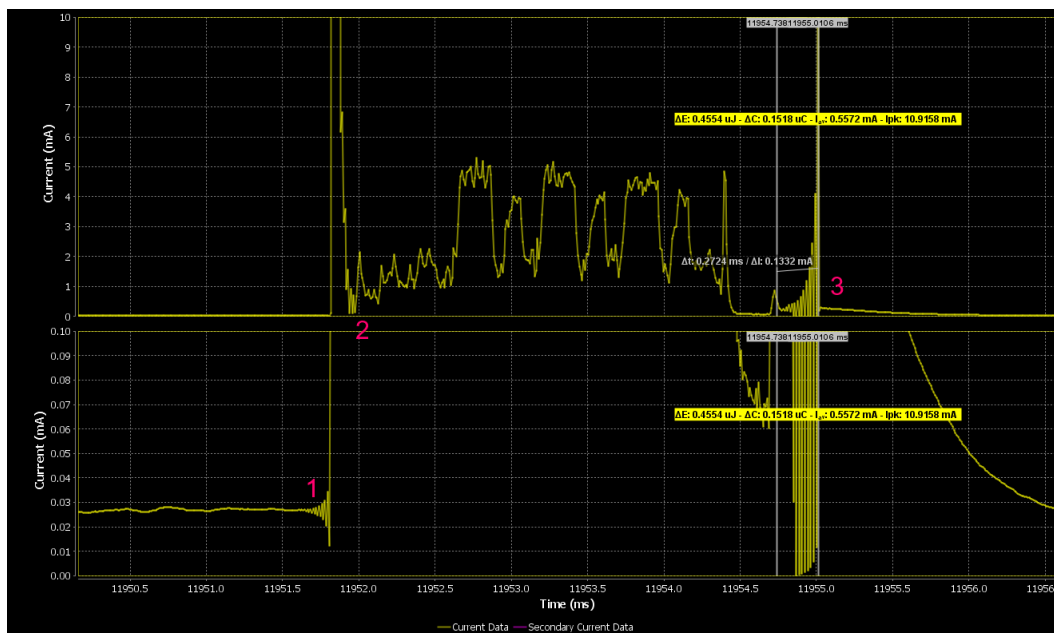

Figure 52: A/D Converter Distortions

In Figure 52 we can identify three types of ringing artifacts created by the A/D converter:

- Switching from low to high scale (1)
- Not switching, but instead a signal with very steep fall is present (2)
- Switching from high to low scale and then another switch Low-High-Low creates this exaggerated false peak (due to a large difference of the DC levels of the two C/V converters, 3)

### 9.2 Push Button SW3

SW3 is enabled on DA145xx DEVKT-P PRO-MB by P1\_1. By default, this signal is not driven from DA14531. Consequently, jumper J19:4-5 is not required in DA14531 DK PRO.

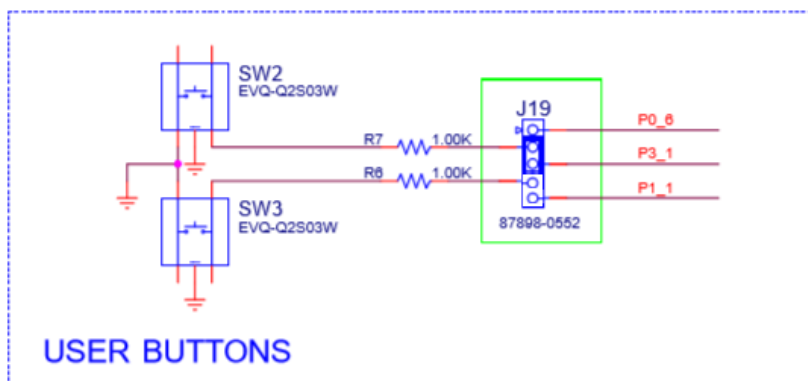

Figure 53: Disable SW3. Remove Jumper from J19:4-5

#### 9.3 mikroBUS Wrong Labels

The label of J18, pin 2 is indicated as P3\_1 but the pin is unconnected.

The label of J17, pin 1 is indicated as P2\_1 but the pin is unconnected.

The labels on J15 pin 2 and J17 pin 2 are indicated as P2\_8 but the pins are connected to P3\_0.

The label of J18 pin 6 is indicated as P3\_0 but the pin is connected to P2\_8.

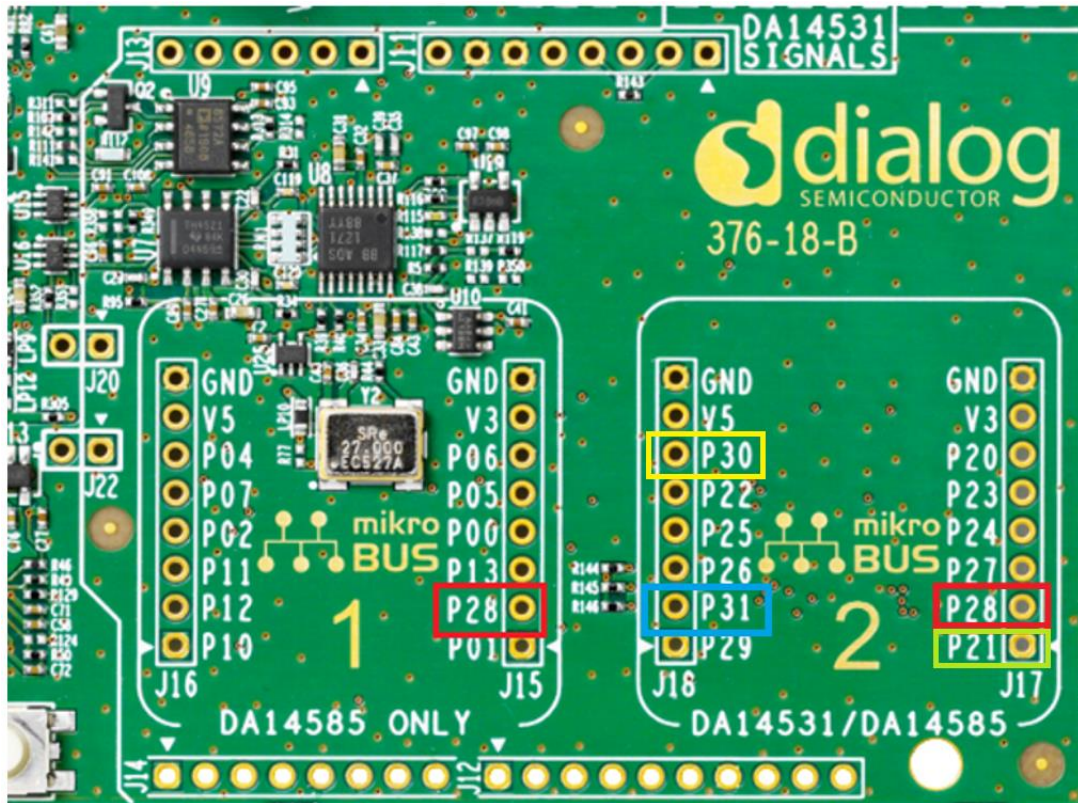

Figure 54: mikroBUS Wrong Label

#### 9.4 4-Wire UART Special Considerations

When the 4-wire UART functionality is used with DA14531 Pro-DB and the reset function is enabled on P0\_0, the chip will not boot and still remain in the reset state.

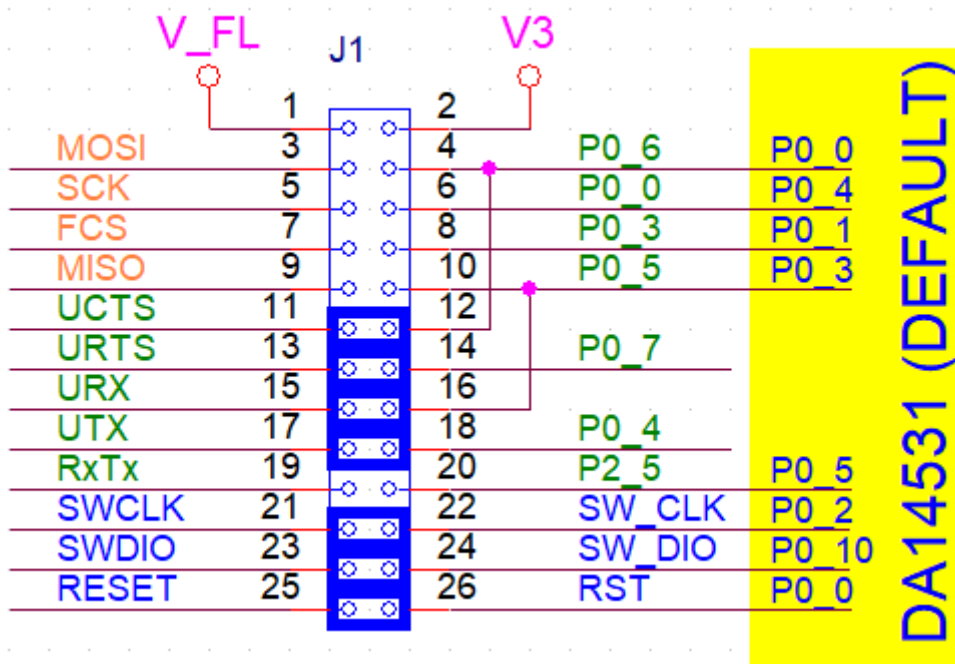
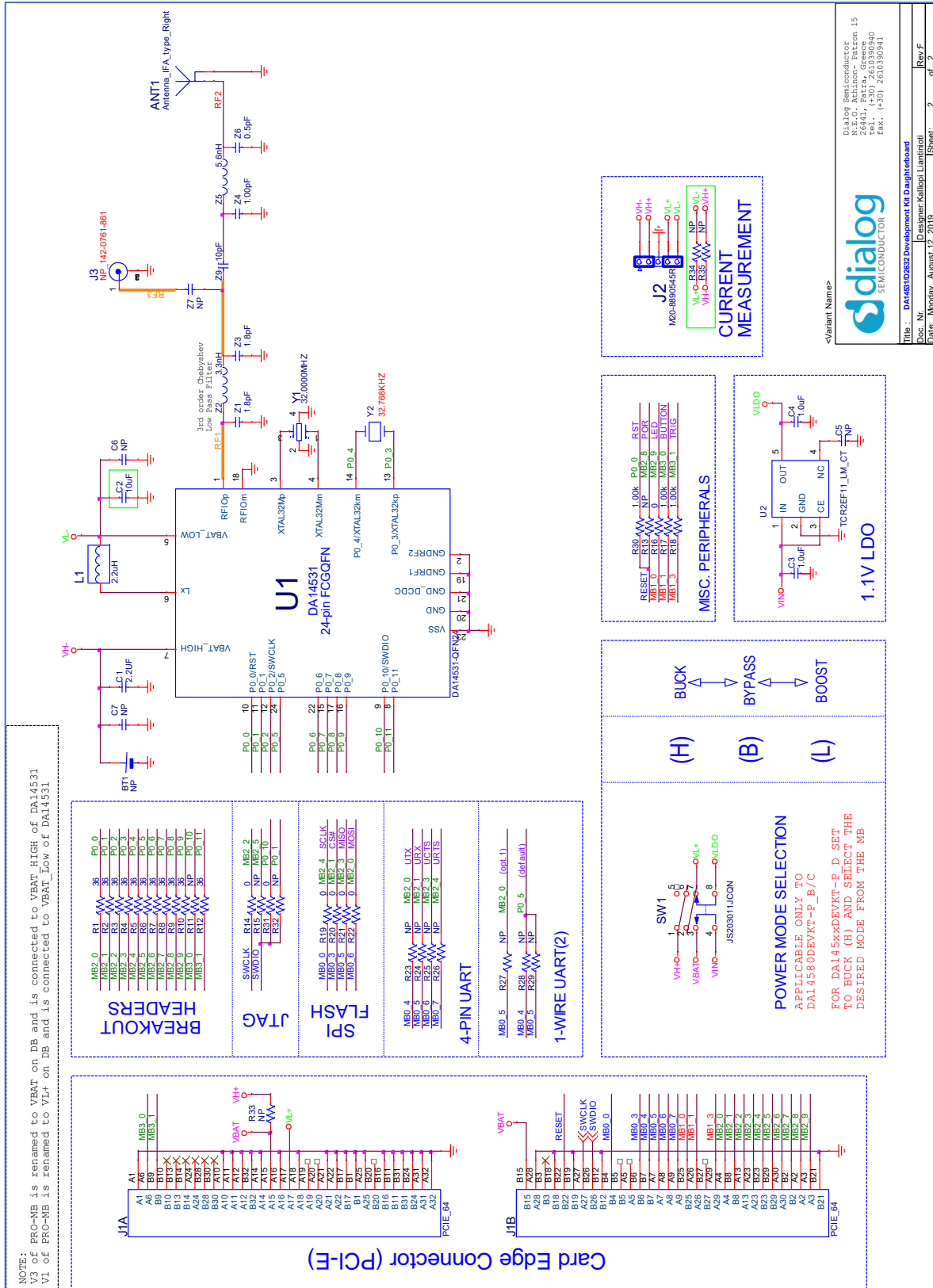

Figure 55: Full UART Configuration - CTS Issue

As shown in Figure 55, the UCTS signal is shorted to P0\_0 when a DA14531 PRO-DB is used. This has been done to maintain compatibility with DA14585 daughterboards. The UCTS signal is an input to the DA14531 and is driven high from the motherboard side (MB\_RTS). If P0\_0 is configured as reset (active high), the motherboard will keep the DA14531 in reset indefinitely and prevent it from booting (the Booter defaults this pin to the reset function between boot steps). To avoid this problem there are several options:

- Disconnect the UCTS jumper and place it after the device has booted and P0\_0 has been configured properly by the firmware for the UCTS function
- Assign UCTS to another free GPIO and wire it accordingly

#### A.1 Schematic





## A.2 Components Placement

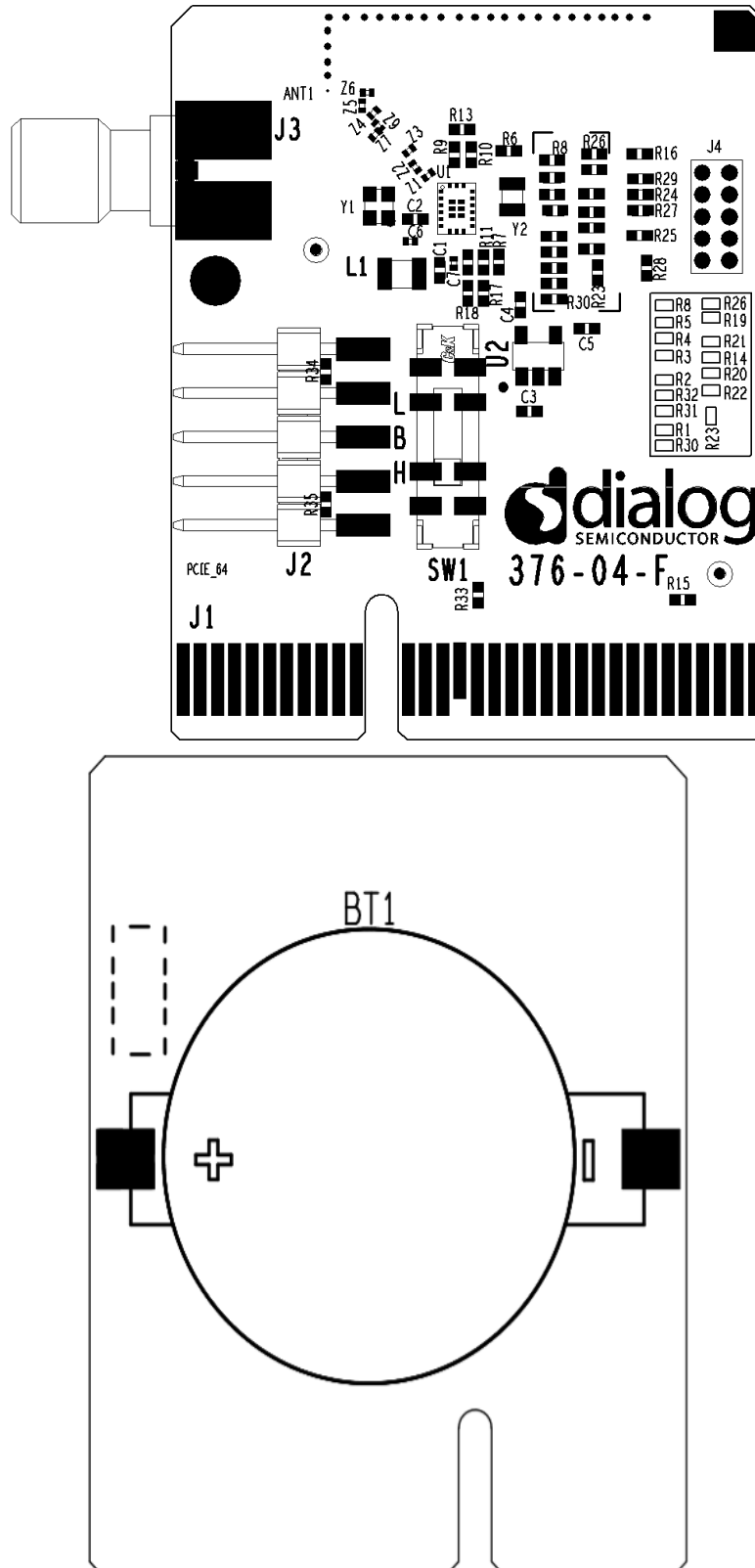
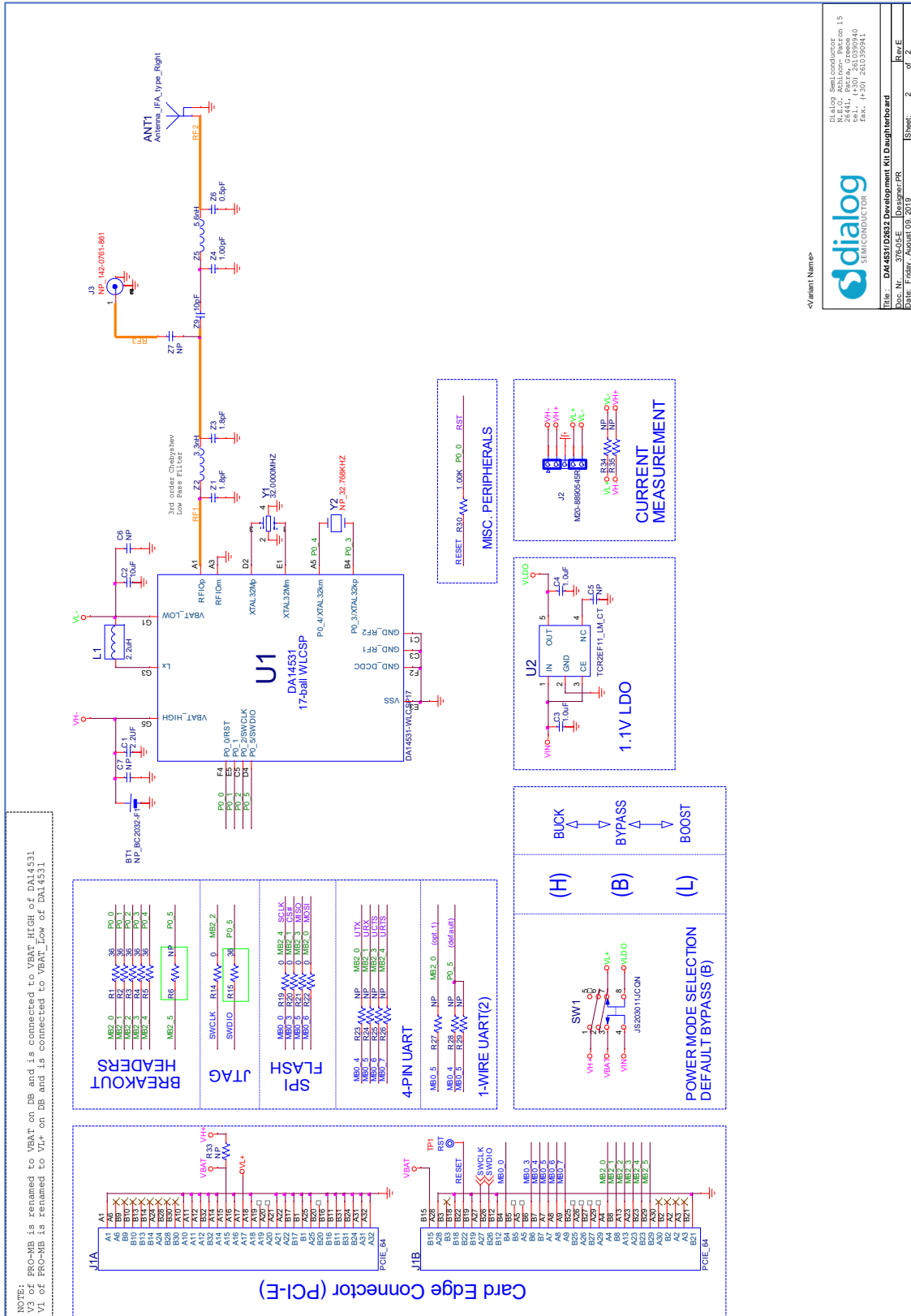

Figure 57: Components on Top and Bottom Sides for FCGQFN24, DA14531-00FXDB-P\_(376-04-F2)

Appendix B WLCSP17 PRO-DB: DA14531-00OGDB-P\_(376-05-E)

B.1 Schematic



<Variant Name>

Dialog Semiconductor  
N.S.G. - Avliano - Patern 15  
Via Salaria, 1019 - 00198 Roma (RM)  
Tel.: +39 06 261039040  
Fax: +39 06 261039941

File: DA14531-00OGDB Development Kit Daughtherboard  
Rev: 2  
Date: E:\dev\About 03\_2019 Sheet: 2 of 2

Figure 58: Schematic, WLCSP17, DA14531-00OGDB-P\_(376-05-E)

B.2 Components Placement

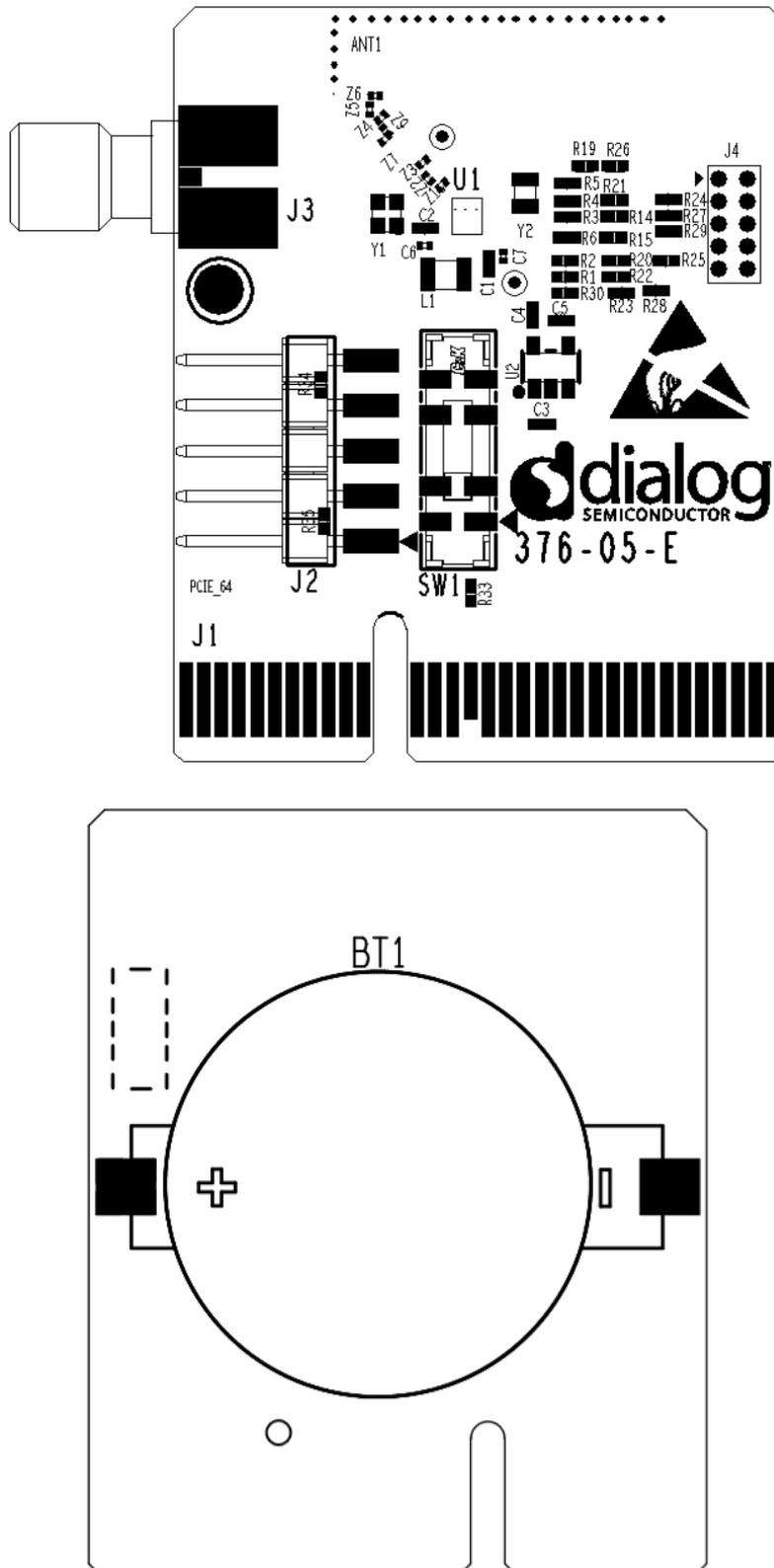

Figure 59: Components on Top and Bottom Sides for WLCSP17, DA14531-00OGDB-P\_(376-05-E)



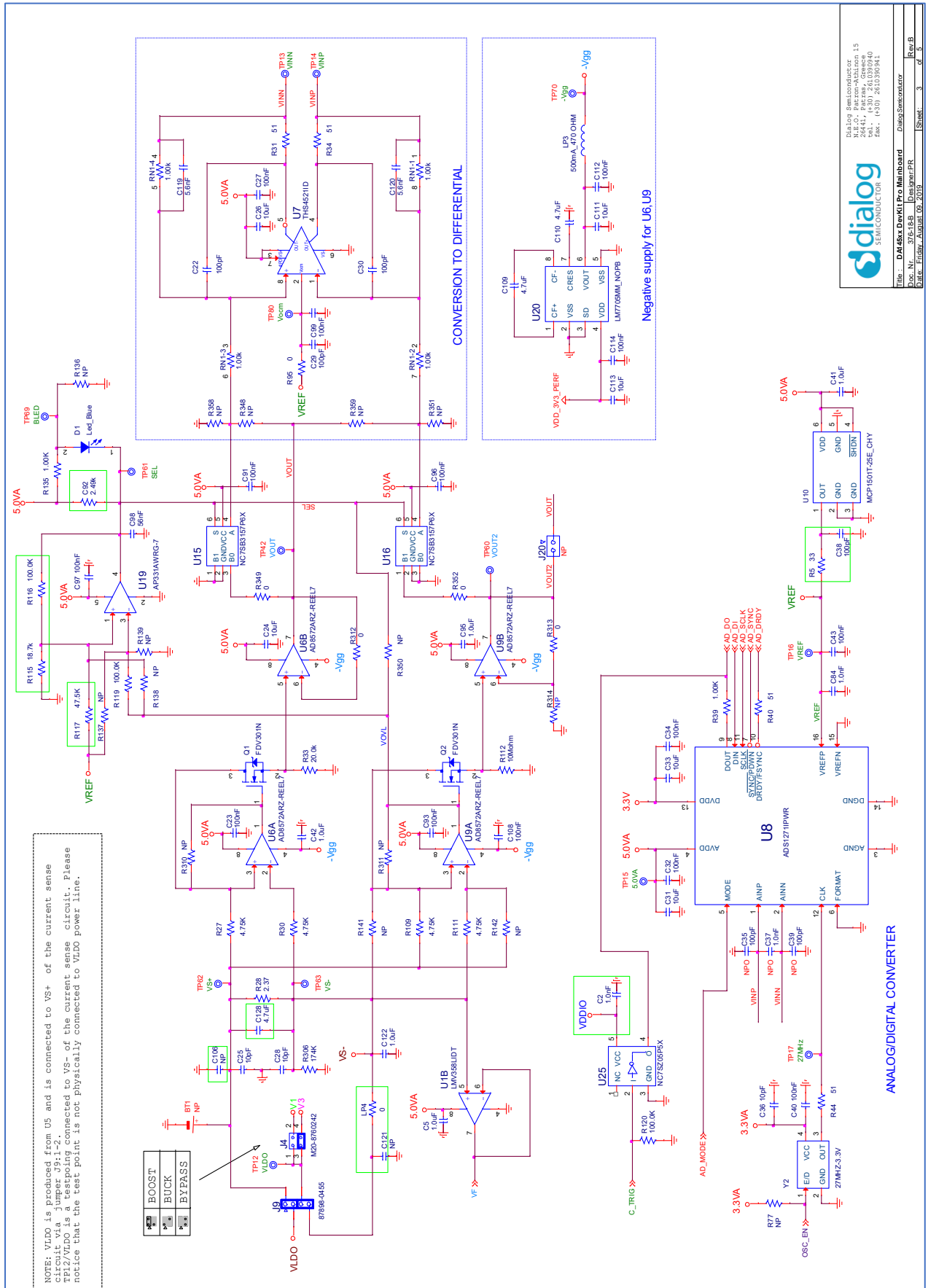
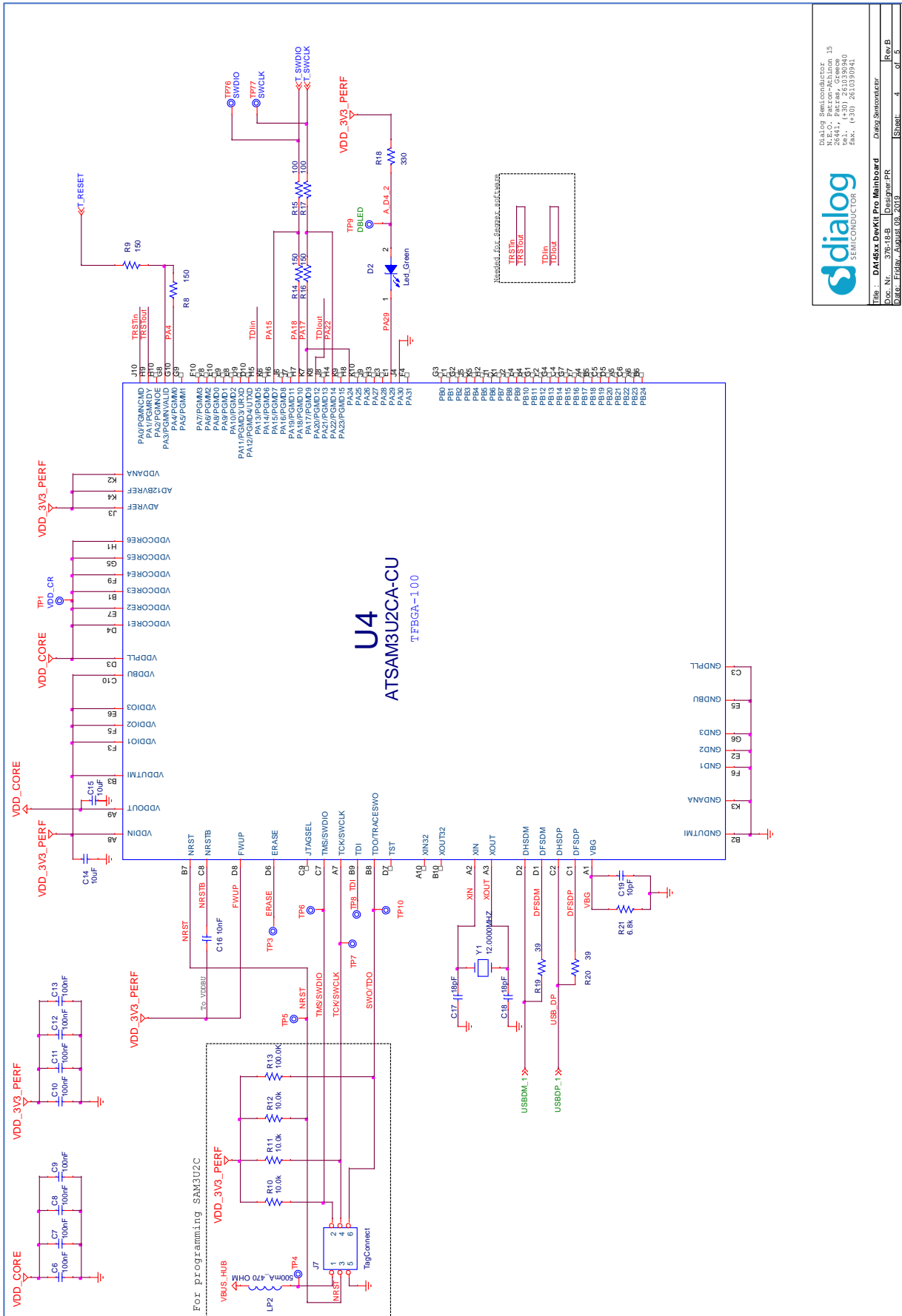

Figure 61: DA14531 PRO-MB, Current Measurement Circuit

Dialog Semiconductor, 15  
 26441, Piacenza, Greece  
 tel.: (+30) 2610390940  
 fax: (+30) 261039941

Dialog Semiconductor  
 DA14531 Development Kit Pro Mainboard  
 Doc. Nr. 376-166 Designer:PR  
 Date: Friday, August 09, 2019 Sheet: 3 of 6 Rev: 6



Dialog Semiconductor  
 N.E.O. Park - Achion 15  
 26441, Palmira, Greece  
 Tel.: (+30) 261039040  
 Fax: (+30) 261039041

Title: DA14531 DevKit Pro Mainboard  
 Doc. Nr.: 376-1-6-B Designer: PR  
 Date: Friday, August 09, 2019  
 Design Simulation  
 Sheet: 4 of 5  
 Rev. B

Figure 62: DA14531 PRO-MB, JTAG MCU

# DA14531 Development Kit Pro Hardware User Manual

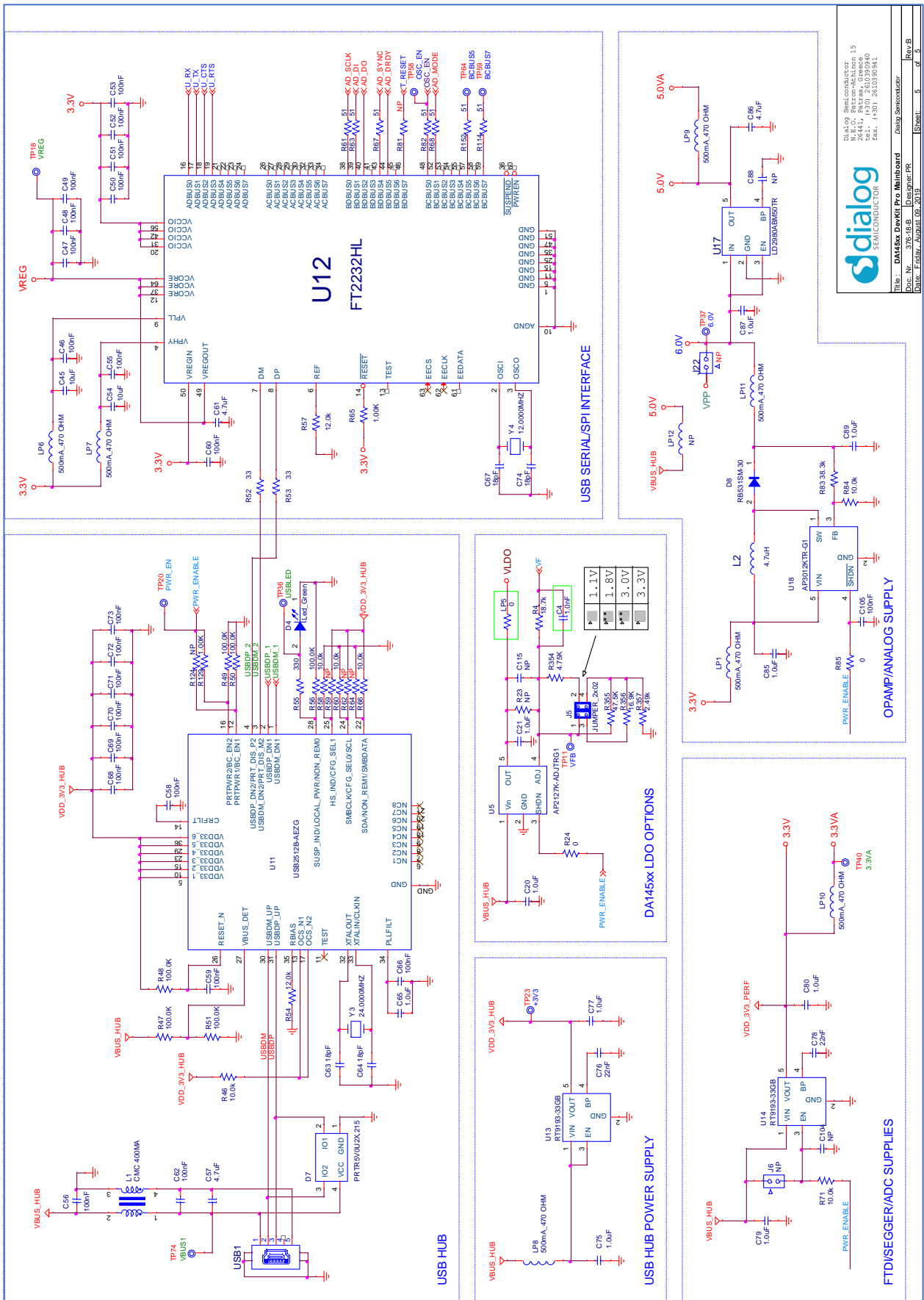

Title: DA14531 DevKit Pro Mainboard		Change Semiconductor	Rev.B
Dwg. No.	3762-B-B	Designer: PK	
Doc. No.	150647-0000 (01/2019)	SYNTH: 5	of 3

DialoG Semiconductor  
DialoG Semiconductor  
N.E.O. Petron-Aktion 15  
59411 • (+30) 261039040  
59411 • (+30) 261039041  
Fax: (+30) 261039041

Figure 63: DA14531 PRO-MB, USB Hub, USB to UART IC, and Power Section

## C.2 Components Placement

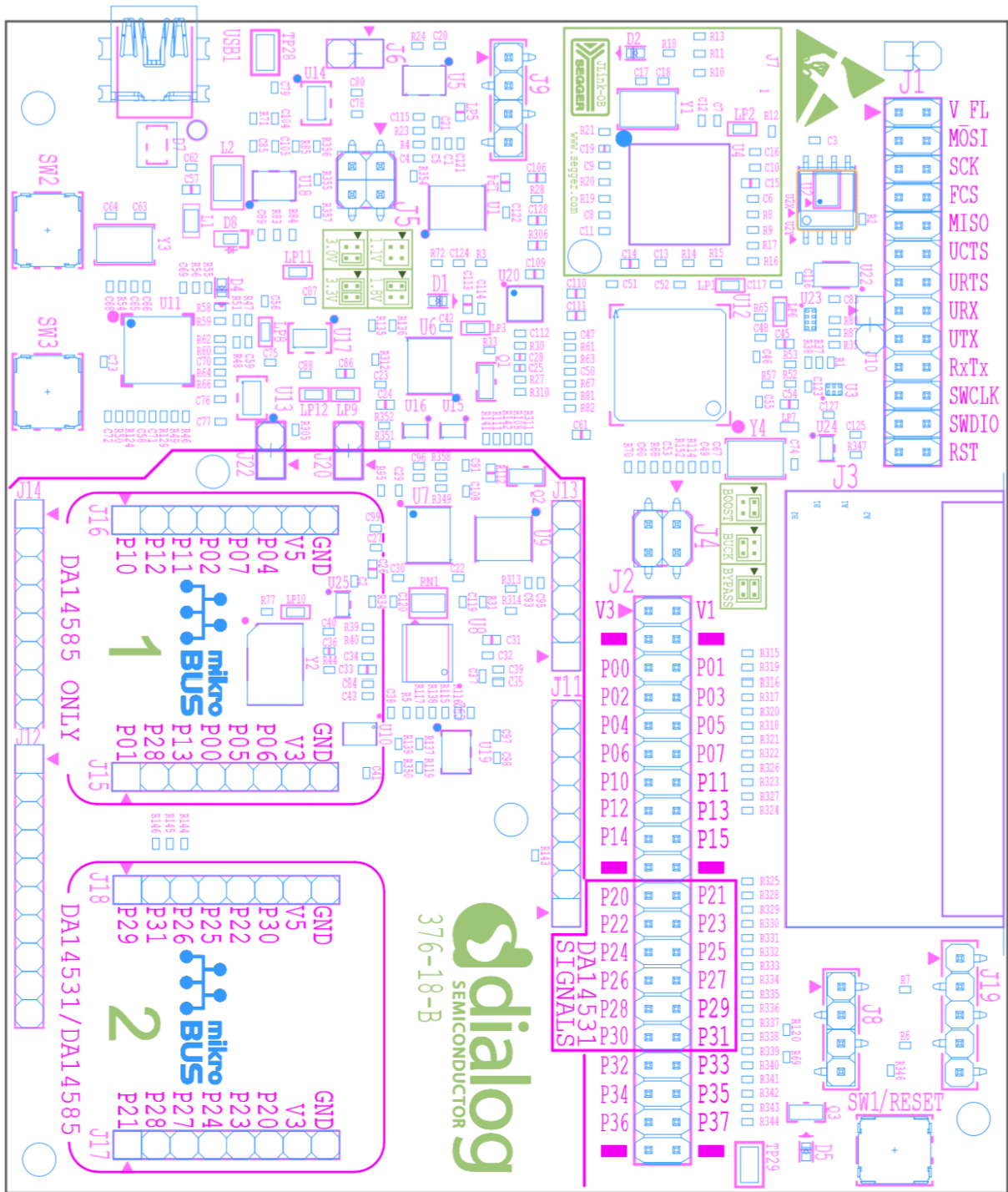

Figure 64: Components on Top Side of DA14531 PRO-MB



## Appendix D Detailed Description of Hardware Setup

### D.1 DA14531 WLCSP17 PRO-DB, GPIOs Configuration, and R-matrix

D14531 WLCSP PRO-DB provides six pins. To serve all the available functions, a resistor matrix (R-Matrix) is applied to DA14531 WLCSP PRO-DB.

Signal multiplication is completed with signal selection header (J1) on PRO-MB.

Functions available for DA14531 WLCSP17 PRO-DB are the SPI data bus, JTAG, Reset, UART, and XTAL32K.

The default setup for the D14531 WLCSP17 PRO-DB is: Reset, JTAG, and SPI data bus (assigned to SPI data flash).

Figure 65 and Table 18 show the resistor matrix for DA14531 WLCSP17 PRO-DB.

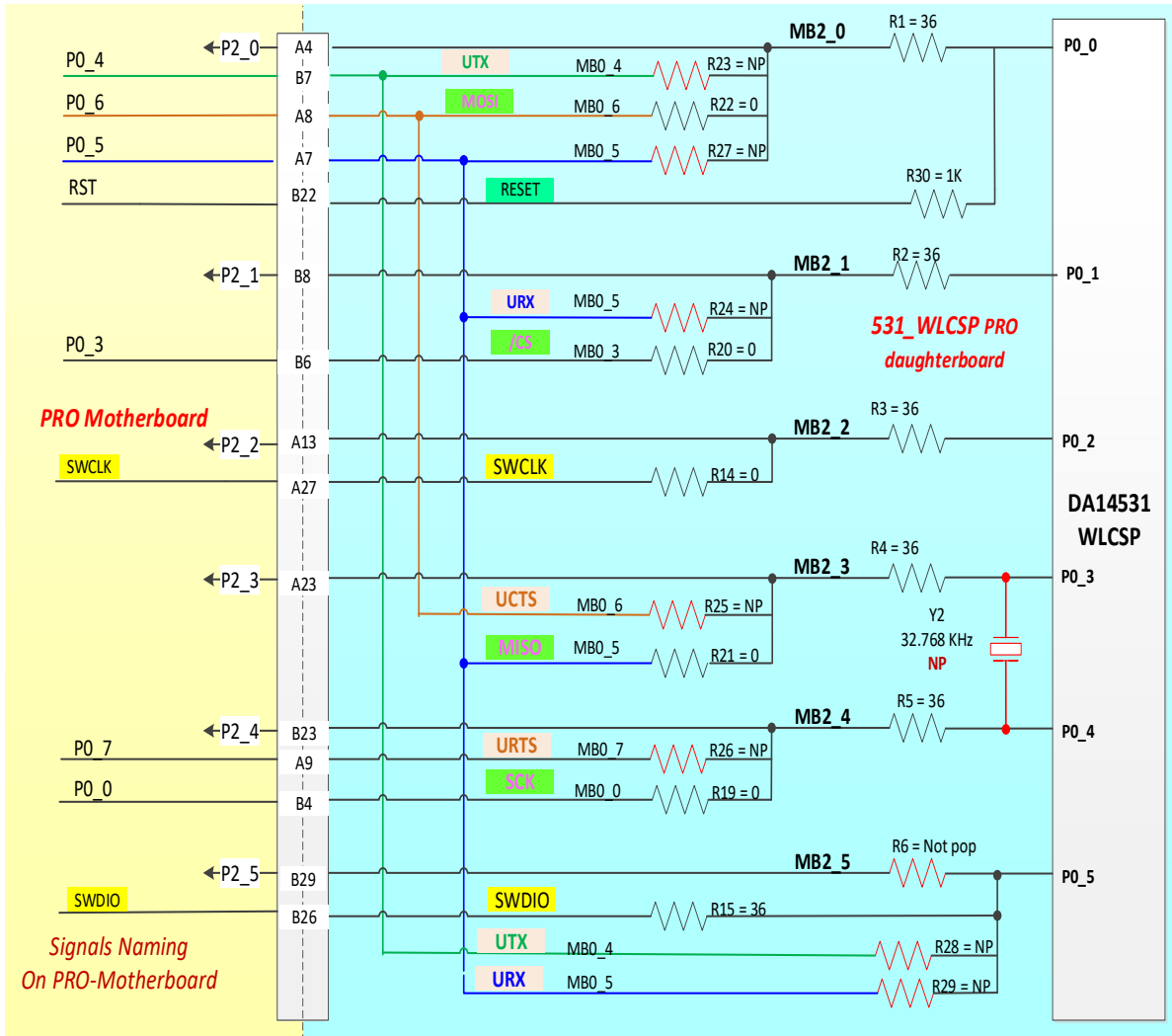

Figure 65: System Configuration for DA14531 DK PRO with a DA14531 WLCSP17 PRO-DB (Default)

**Table 18: DA4531 WLCSP17 PRO-DB Default Setup**

		DA14531 WLCSP17 PRO-DB Pin Connectivity					
Interfaces	Signals	P0_0	P0_1	P0_2	P0_3	P0_4	P0_5
PRO-MB signals	P2_0	R1					
	P2_1		R2				
	P2_2			R3			
	P2_3				R4		
	P2_4					R5	
	P2_5						R6
UART	UTX	R23					R28
	URX	R27	R24				R29
	URTS					R26	
	UCTS				R25		
SPI Data Flash	MOSI	R22					
	MISO				R21		
	SCS		R20				
	SCL					R19	
JTAG	SWCLK			R14			
	SWDIO						R15
XTAL32K	XT32Kp				Y2		
	XT32Km					Y2	
Other	Reset	R30					

## D.2 DA14531 FCGQFN24 PRO-DB, GPIOs Configuration, and R-matrix

DA14531 FCGQFN24 PRO-DB provides 12 pins. To serve all the available functions, a resistor matrix (R-Matrix) is applied to DA14531 FCGQFN24 PRO-DB.

Signal multiplication is completed with the signal selection headers (J1, J8, and J19) on PRO-MB.

Functions available for DA14531 FCGQFN24 PRO-DB are the SPI data bus, JTAG, Reset, UART, XTAL32K, LED, Key, and extension ports (mikroBUS and Arduino).

The default setup for the D14531 FCGQFN24 PRO-DB is: Reset, JTAG, and SPI data bus (assigned to SPI data flash), single-wire UART, LED and a Key. Extension ports use multiplexed signals.

Figure 66 and Table 19 show the resistor matrix for FCGQFN24.

DA14531 Development Kit Pro Hardware User Manual

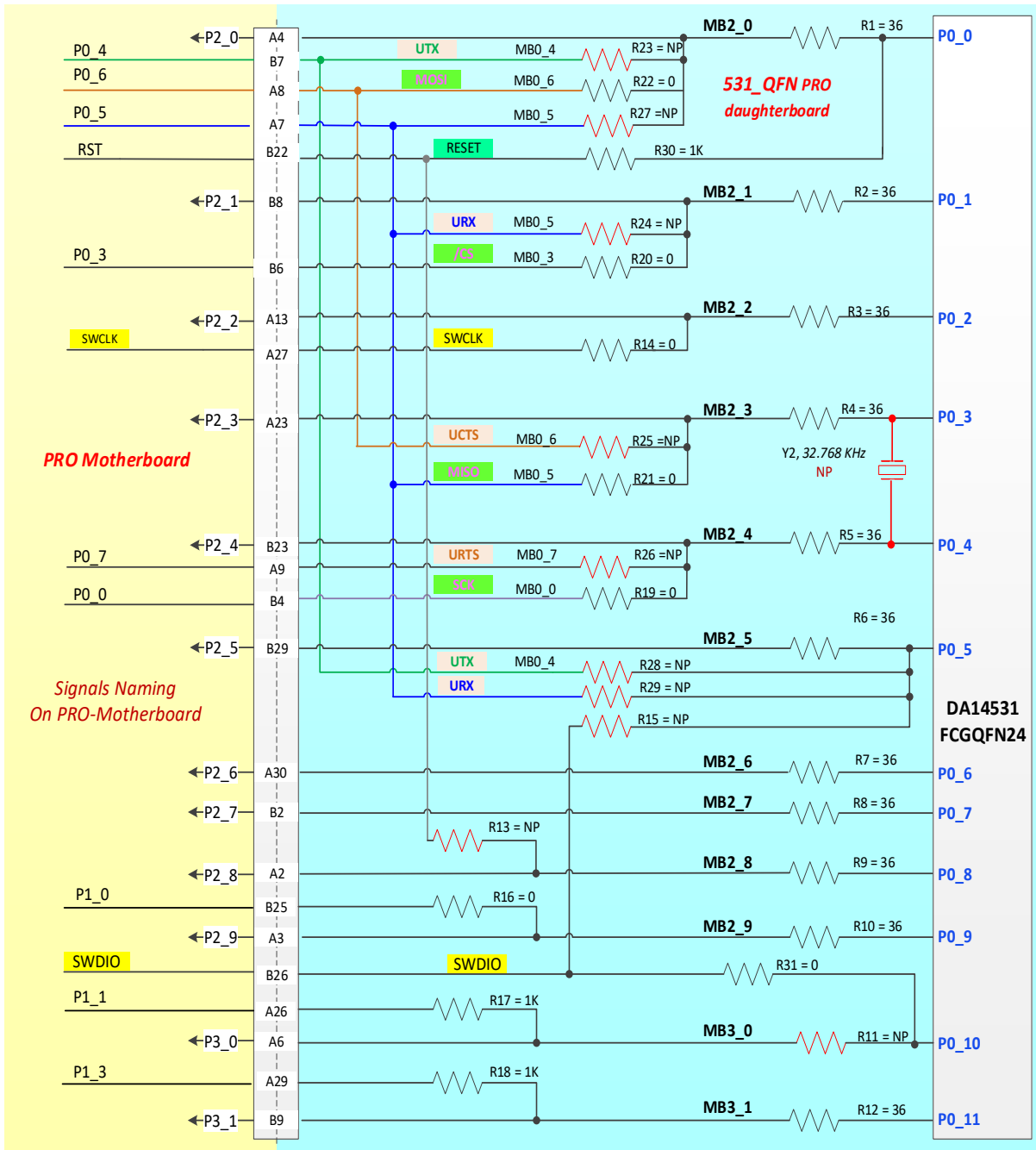

Figure 66: System Configuration for DA14531 DK PRO with a DA14531 FCGQFN24 PRO-DB (Default)

**Table 19: DA4531 FCGQFN24 PRO-DB Default Setup**

		DA4531 FCGQFN24 PRO-DB Pin Connectivity											
Interfaces	Signals	P0_0	P0_1	P0_2	P0_3	P0_4	P0_5	P0_6	P0_7	P0_8	P0_9	P0_10	P0_11
PRO-MB signals	P2_0	R1											
	P2_1		R2										
	P2_2			R3									
	P2_3				R4								
	P2_4					R5							
	P2_5						R6						
	P2_6							R7					
	P2_7								R8				
	P2_8									R9			
	P2_9										R10		
	P3_0											R11	
	P3_1												R12
UART	UTX	R23					R28						
	URX	R27	R24				R29						
	URTS												
	UCTS				R25								
SPI Data Flash	MOSI	R22											
	MISO				R21								
	SCS		R20										
	SCL					R19							
JTAG	SWCLK			R14									
	SWDIO		R32				R15					R31	
XTAL32K	XT32Kp				Y2								
	XT32Km					Y2							
Other	RESET	R30								R13			
	BUTTON											R17	
	LED										R16		
	SW_TRIG												R18

## Appendix E SPI Data Flash, JTAG, and Single-Wire UART (Default)

This is the default configuration for DA14531 DK PRO shipped to users.

In the FCGQFN24 package, SWDIO is assigned to P0\_10. P0\_5 is used during boot as the single-wire UART, RxTx. This is not feasible for the WLCSP17 package.

**Table 20: Pin Assignment for DA14531 WLCSP17 PRO-DB**

Configuration	P0_0	P0_1	P0_2	P0_3	P0_4	P0_5
SPI, JTAG, and single-wire UART	MOSI	/CS	SWLCK	MISO	MOSI	SWDIO

**Table 21: Pin Assignment for DA14531 FCGQFN24 PRO-DB**

Configuration	P0_0	P0_1	P0_2	P0_3	P0_4	P0_5	P0_10
SPI, JTAG, and single-wire UART	MOSI	/CS	SWLCK	MISO	MOSI	RxTx	SWDIO

### E.1 DA14531 WLCSP17 PRO-DB and PRO-MB Settings

The resistors that are not mounted to DA14531 WLCSP17 PRO-DB do not appear in [Figure 67](#)

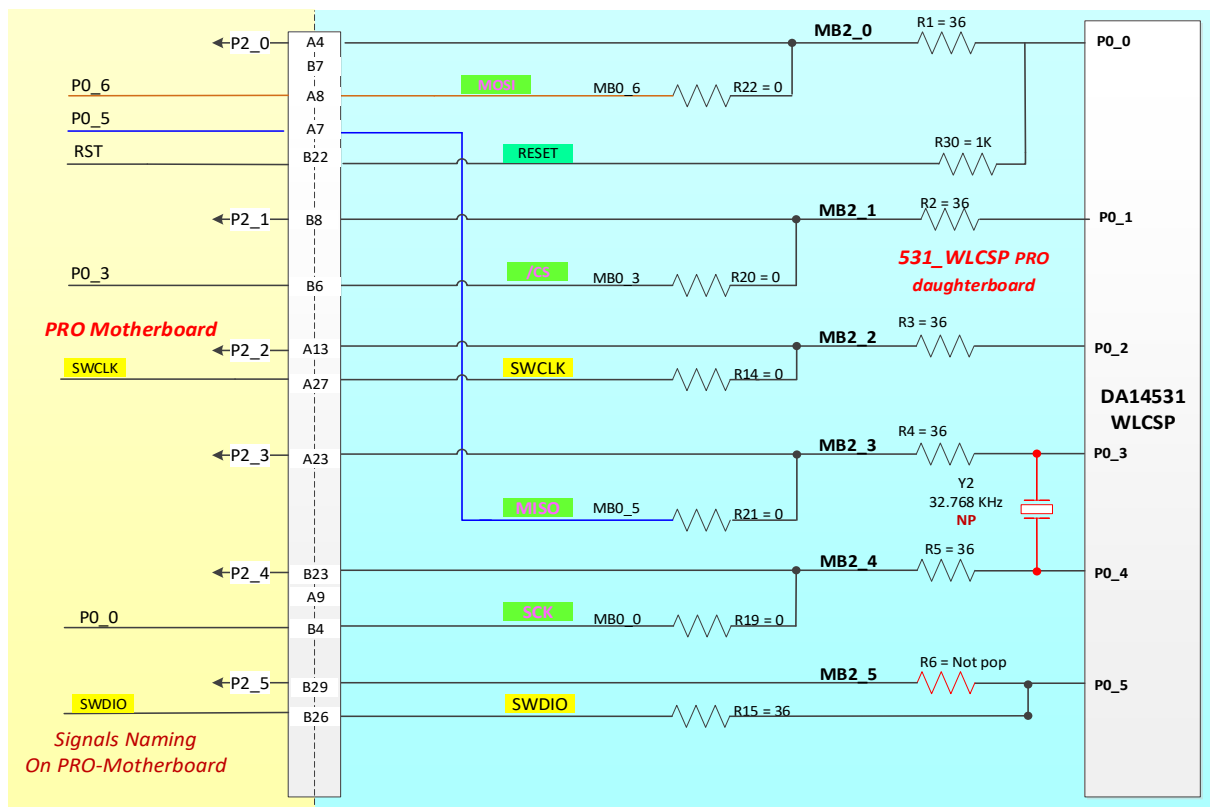

**Figure 67: System Configuration for DA14531 DK PRO with a DA14531 WLCSP17 PRO-DB (Default)**

Table 22: The Components for DA14531 DK PRO in WLCSP17 Package

Package	Populated components	Removed components
PRO-MB	Apply jumpers: J1:1-2, J1:3-4, J1:5-6, J1:7-8, J1:9-10, J1:21-22, J1:23-24, J1:25-26 J9:1-2, J9:3-4 J4: as per power configuration J5: as per power configuration	
DA14531-WLCSP17 PRO-DB	R1, R2, R3, R4, R5, R14, R15, R19, R20, R21, R22, R30	R6, R23, R24, R25, R26, R27, R28, R29, R33, R34, R35, Y2

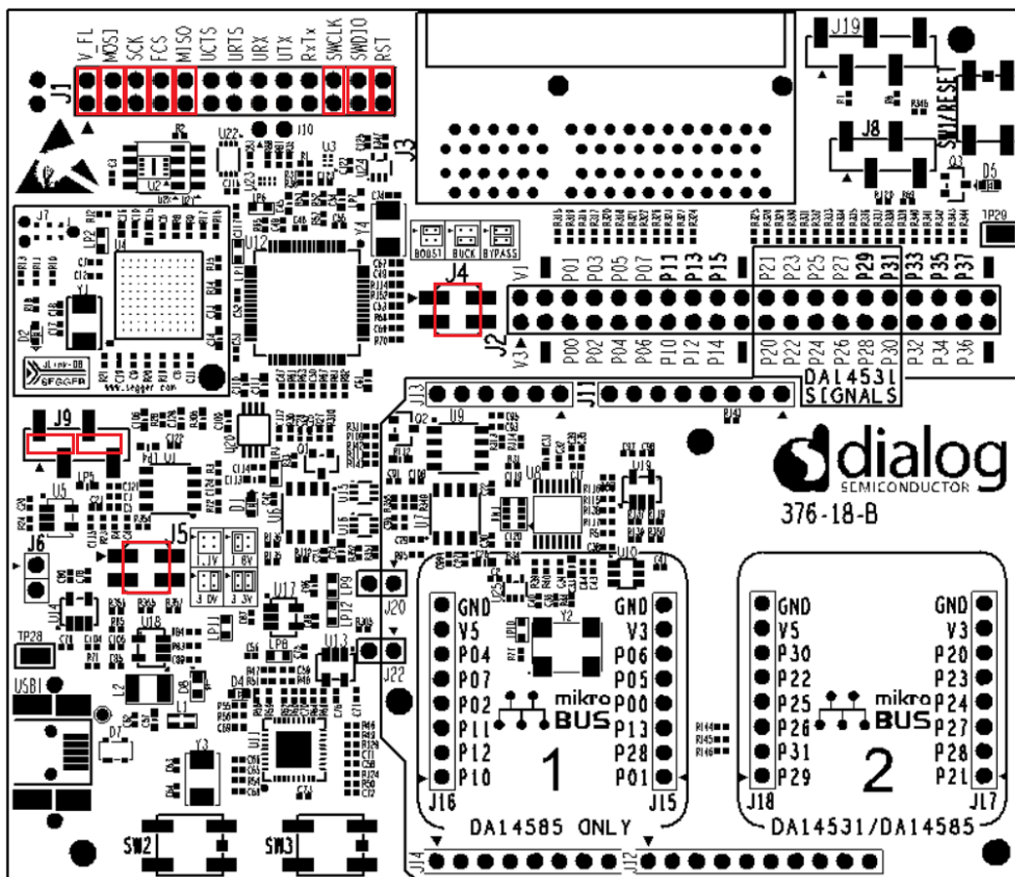

Figure 68: Jumper Settings for PRO-MB (Marked in Red)



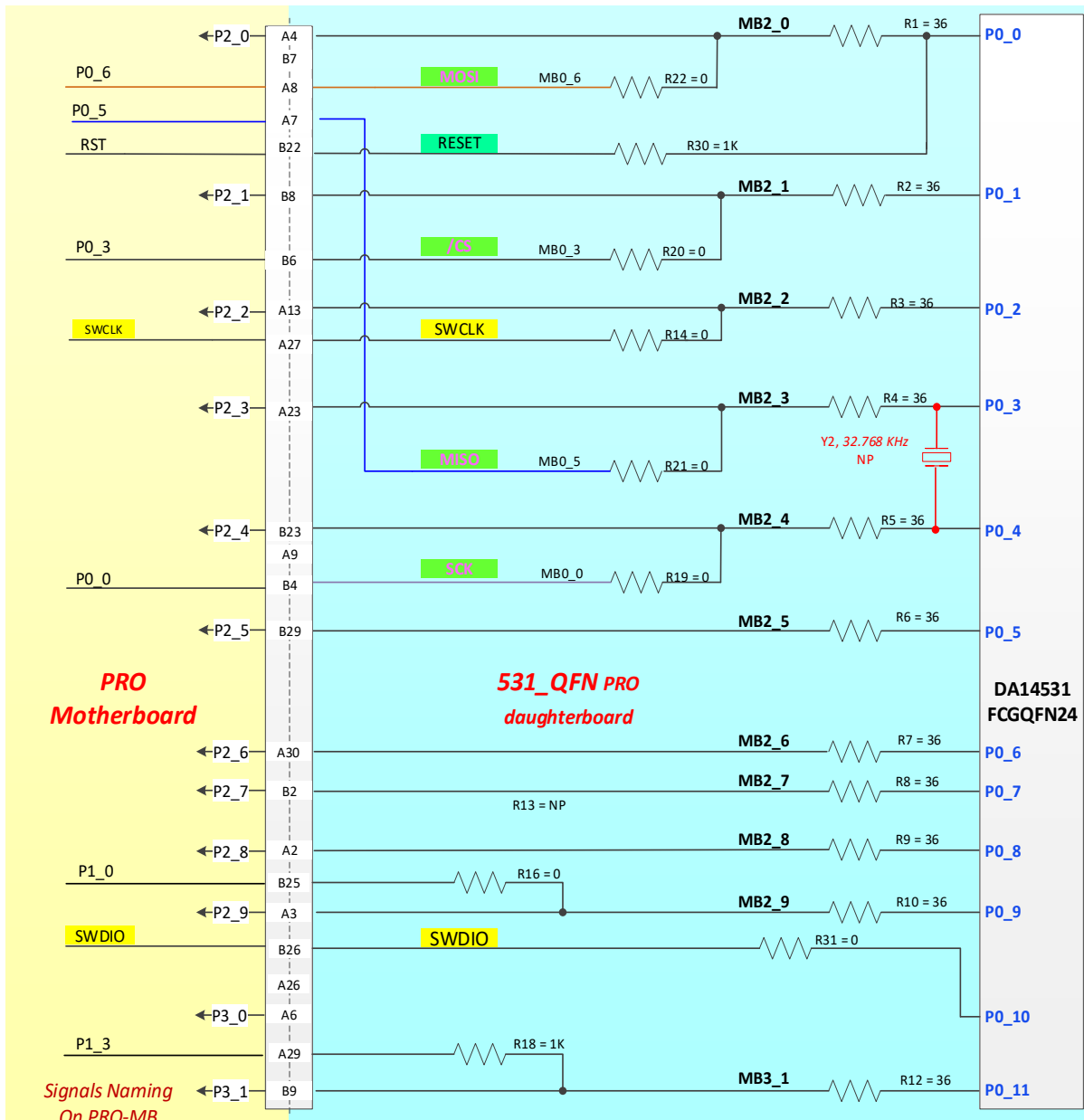

Figure 70: System Configuration for DA14531 DK PRO with a DA14531 FCGQFN24 PRO-DB (Default)



Table 23: The Components for DA14531 DK PRO in FCGQFN24 Package

PCBA	Populated Components	Not Populated Components
PRO-MB	Apply jumpers: J1:1-2, J1:3-4, J1:5-6, J1:7-8, J1:9-10, J1:21-22, J1:23-24, J1:25-26 J9:1-2, J9:3-4 J4: as per power configuration J5: as per power configuration For single-wire UART, add jumpers to: J1:19-20, J10:1 to J1:15, J10:2 to J1:17	
DA14531-FCGQFN24	R1, R2, R3, R4, R5, R6, R7, R8, R8, R9, R10, R12, R14, R16, R17, R18, R19, R20, R21, R22, R30, R31	R11, R13, R15, R23, R24, R25, R26, R27, R28, R29, R33, R34, R35, Y2

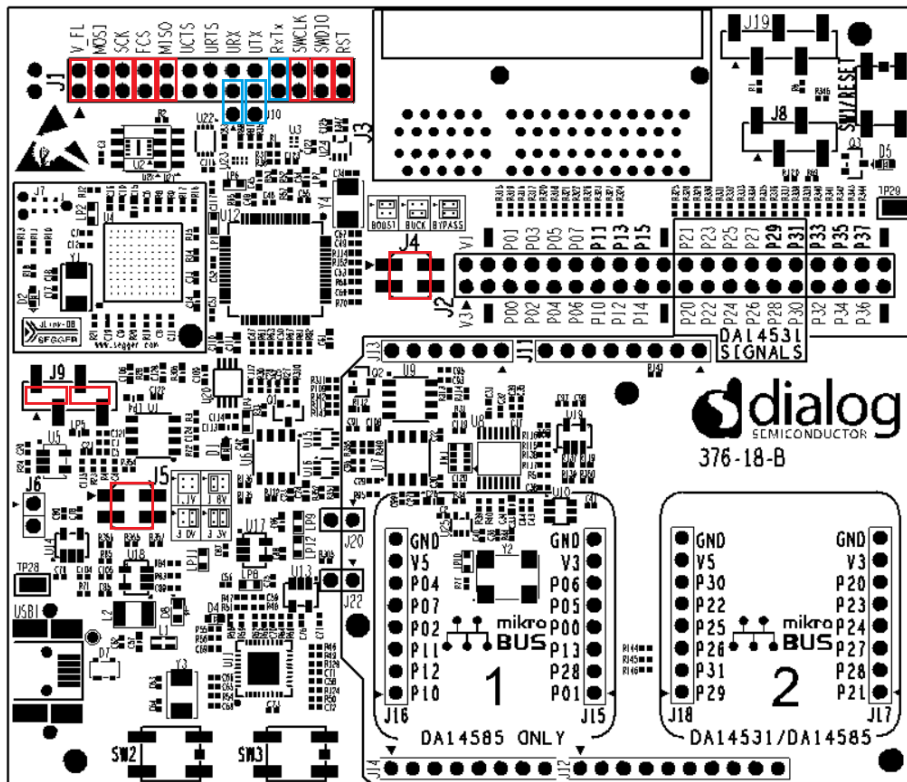
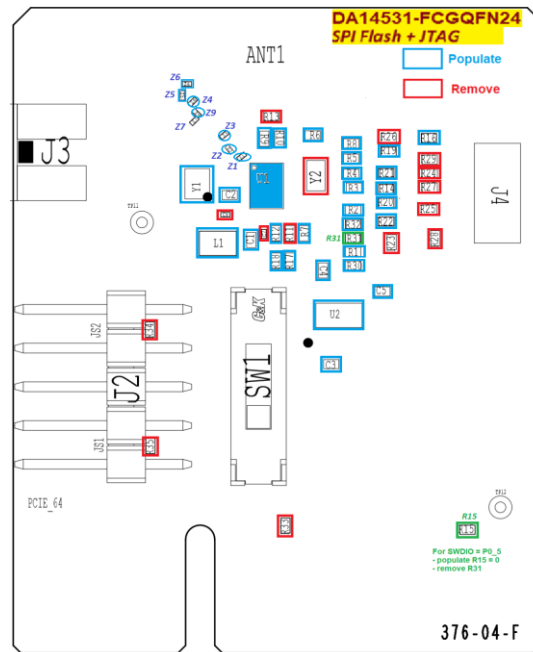

Figure 71: Jumper Settings for PRO-MB



**Figure 72: Resistor and Jumper Settings for DA14531 FCGQFN24 PRO-DB**

## Appendix F Enabling UART, JTAG and 32.768 kHz Crystal

### F.1 UART (2-wire), JTAG, and 32.768 kHz Crystal

In this configuration, the 2-wire UART, JTAG, 32.768 kHz crystal, and reset are applied. No cables are required because the signal assignment is done on the PRO-DB with proper resistor mounting. In PRO-MB, the appropriate jumper setting is applied on J1.

**Table 24: Pin Assignment for DA14531 WLCSP17 PRO-DB**

Configuration	P0_0	P0_1	P0_2	P0_3	P0_4	P0_5
UART (2-wire), JTAG, and 32.768 kHz Crystal	UTX/Reset	URX	SWLCK	XTAL	XTAL	SWDIO

**Table 25: Pin assignment for DA14531 FCGQFN24 PRO-DB**

Configuration	P0_0	P0_1	P0_2	P0_3	P0_4	P0_10
UART (2-wire), JTAG, and 32.768 kHz Crystal	UTX/Reset	URX	SWLCK	XTAL	XTAL	SWDIO

**Table 26: The Components for the Two Packages to Support 2-Wire UART, JTAG, and 32.768 kHz Crystal**

Package	Populated components	Removed components
DA145xx PRO-MB	Apply jumpers: J1:15-16, J1:17-18, J1:21-22, J1:23-24, J1:25-26 J9:1-2, J9:3-4 J4: as per power configuration J5: as per power configuration	
DA14531- WLCSP17	R1, R2, R3, R4, R5, R23, R24, R14, R15, R30, Y2	R6, R19, R20, R21, R22, R25, R26 R27, R28, R29 R33, R34, R35
DA14531-FCGQFN24	R1, R2, R3, R6, R7, R8, R9, R10, R12, R14, R16, R17, R18, R23, R24, R30, R31, Y2	R4, R5, R11, R13, R15, R19, R20, R21, R22, R25, R26, R27, R28, R29

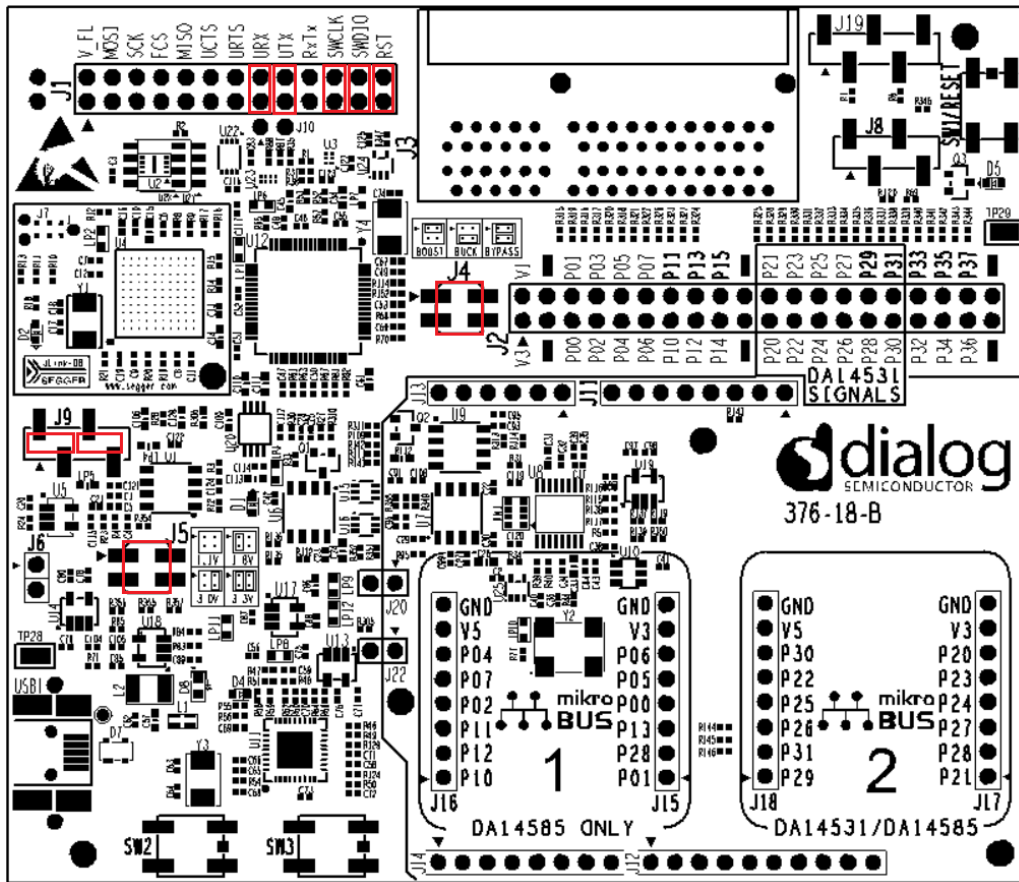

PRO-MB Jumpers (in Red)

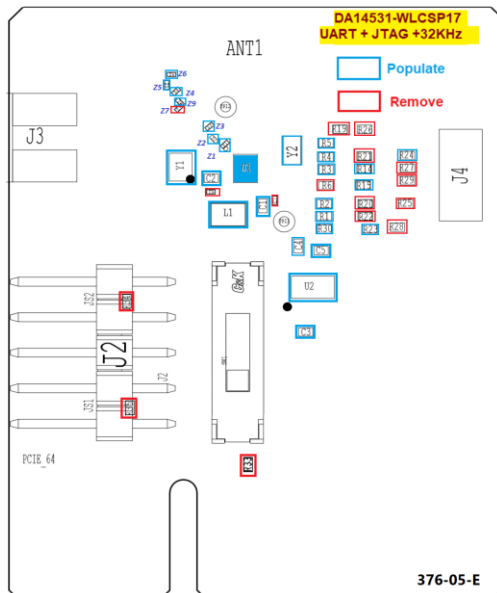

WLCSP17

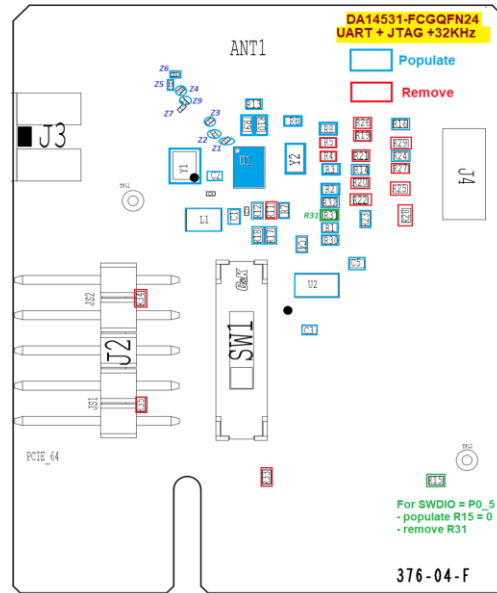

FCGQFN24

Figure 73: Resistor and Jumper Setting for PRO-MB (Top) and DA14531 PRO-DBs (Bottom) to Support 2-Wire UART, JTAG, and 32.768 kHz Crystal

**F.2 Full UART and JTAG**

In this configuration, the 4-wire full UART, JTAG, and reset are applied. No cables are required because the signal assignment is done on the PRO-DB with proper resistor mounting. In PRO-MB, the appropriate jumper setting is applied on J1.

**Table 27: Pin Assignment for DA14531 WLCSP17 PRO-DB**

Configuration	P0_0	P0_1	P0_2	P0_3	P0_4	P0_5
Full UART (4-wire) and JTAG	UTX/Reset	URX	SWLCK	UCTS	URTS	SWDIO

**Table 28: Pin Assignment for DA14531 FCGQFN24 PRO-DB**

Configuration	P0_0	P0_1	P0_2	P0_3	P0_4	P0_10
Full UART (4-wire) and JTAG	UTX/Reset	URX	SWLCK	UCTS	URTS	SWDIO

**Table 29: The Components for the Two Packages to Support Full UART and JTAG**

Package	Populated components	Removed components
PRO-MB	Apply jumpers J1:11-12, J1:13-14, J1:15-16, J1:17-18, J1:21-22, J1:23-24, J1:25-26 J9:1-2, J9:3-4 J4: as per power configuration J5: as per power configuration	
DA14531 WLCSP17 PRO-DB	R1, R2, R3, R4, R5, R14, R15, R23, R24, R25, R26, R30	R6, R19, R20, R21, R22, R27, R28, R29, R33, R34, R35, Y2
DA14531 FCGQFN24 PRO-DB	R1, R2, R3, R4, R5, R6, R7, R8, R8, R9, R10, R12, R14, R16, R17, R18, R23, R24, R25, R26, R30, R31	R11, R13, R15, R19, R20, R21, R22, R27, R28, R29, R33, R34, R35, Y2

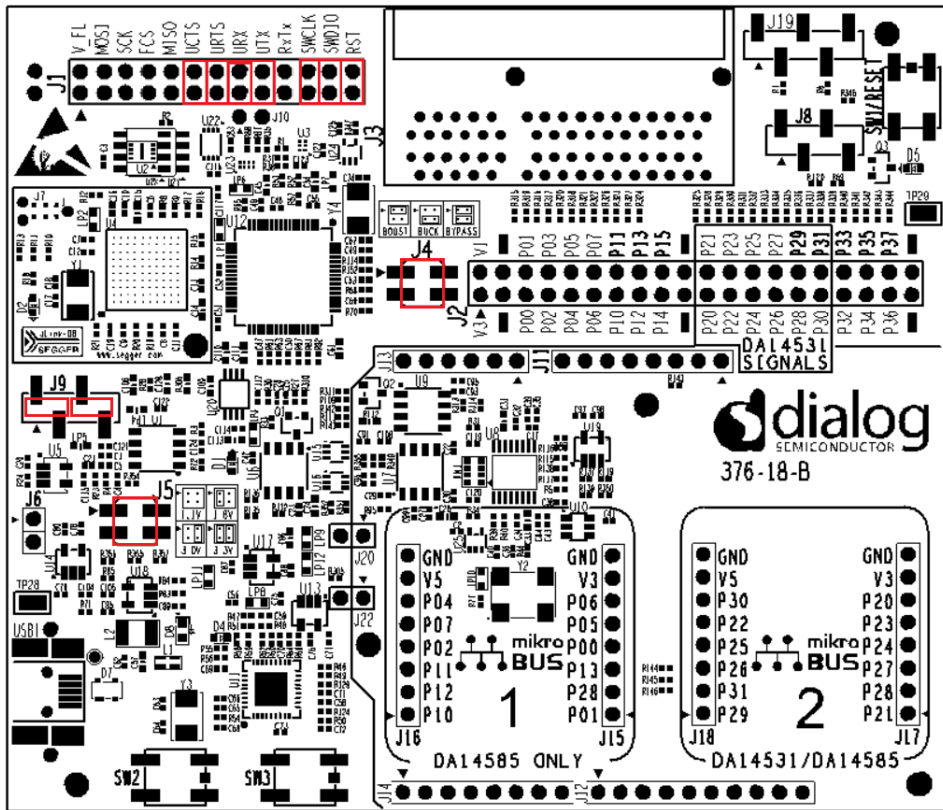

PRO MB jumpers (in red)

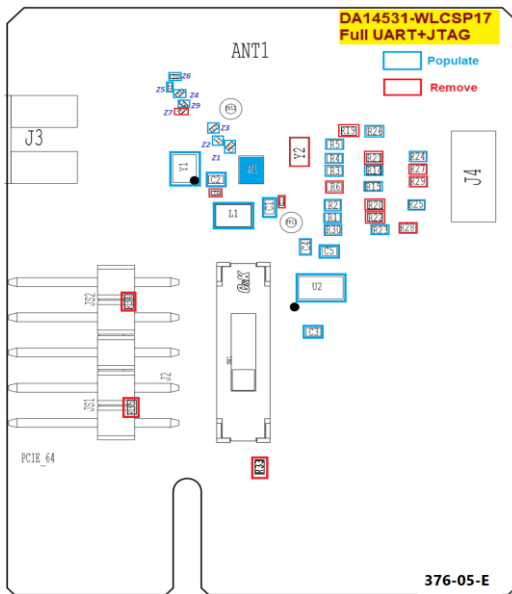

WLCSP17

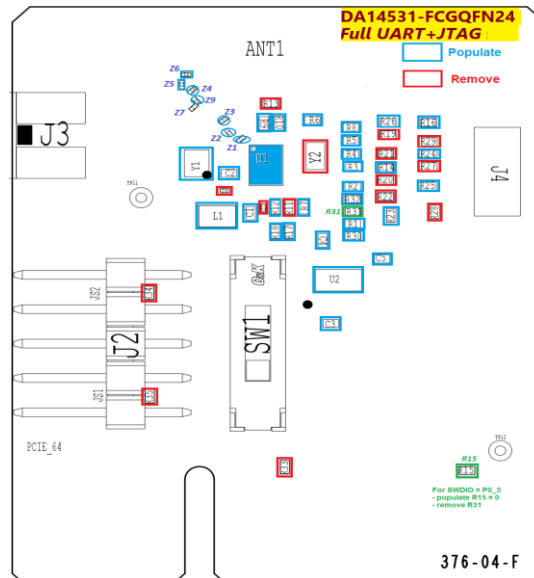

FCGQFN24

Figure 74: Resistor and Jumper Setting for PRO-MB (Top) and DA14531 PRO-DBs (Bottom) to Support Full UART AND JTAG

## Appendix G Operating the DK PRO at 1.5V (boost mode)

Jumpers J4 and J5 on the PRO Development Kit allow the DA14531 to be operated in buck, boost and bypass mode at 1.1V, 1.8V, 3.0V or 3.3V (Figure 75).

In order to operate in boost mode with a different voltage, except of 1.1V, additional components or equipment must be used. Instructions on how to configure a voltage of 1.5V, while maintaining power profiler and current measurement functionality over the PRO Development Kit, are presented in the following sections.

### G.1 Adding external resistor to VLDO Selection (J5) pin header

1. Remove the jumpers from J5
2. Connect a 31.6K Ohm 1% resistor (which is an E96 standard value) between pins 1 and 4.
3. Verify that jumper on J4 is on position 1:2

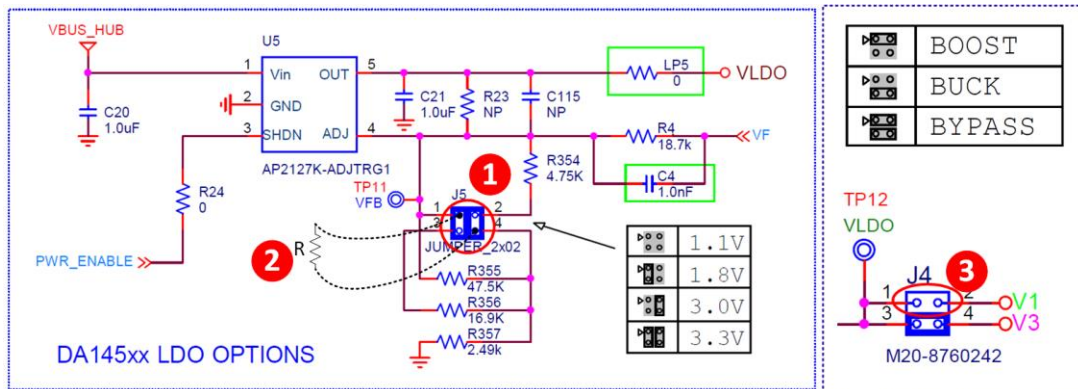

Figure 75: Configuring VLDO for 1.5V boost operation

### G.2 Using external power supply

1. Remove jumper J9:1-2
2. Connect V+ (1.5V) of external supply on pin 1 and GND to an available GND point on a breakout header
3. Verify that jumper on J4 is on position 1:2

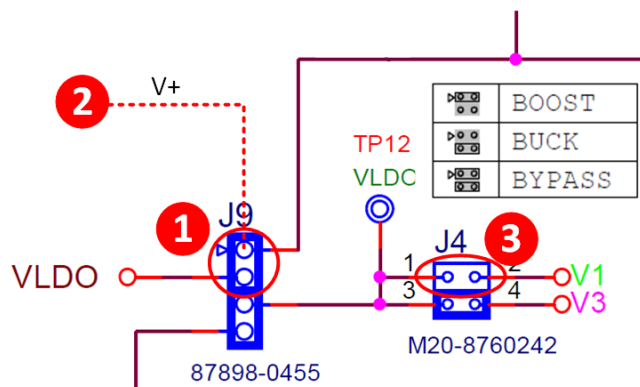
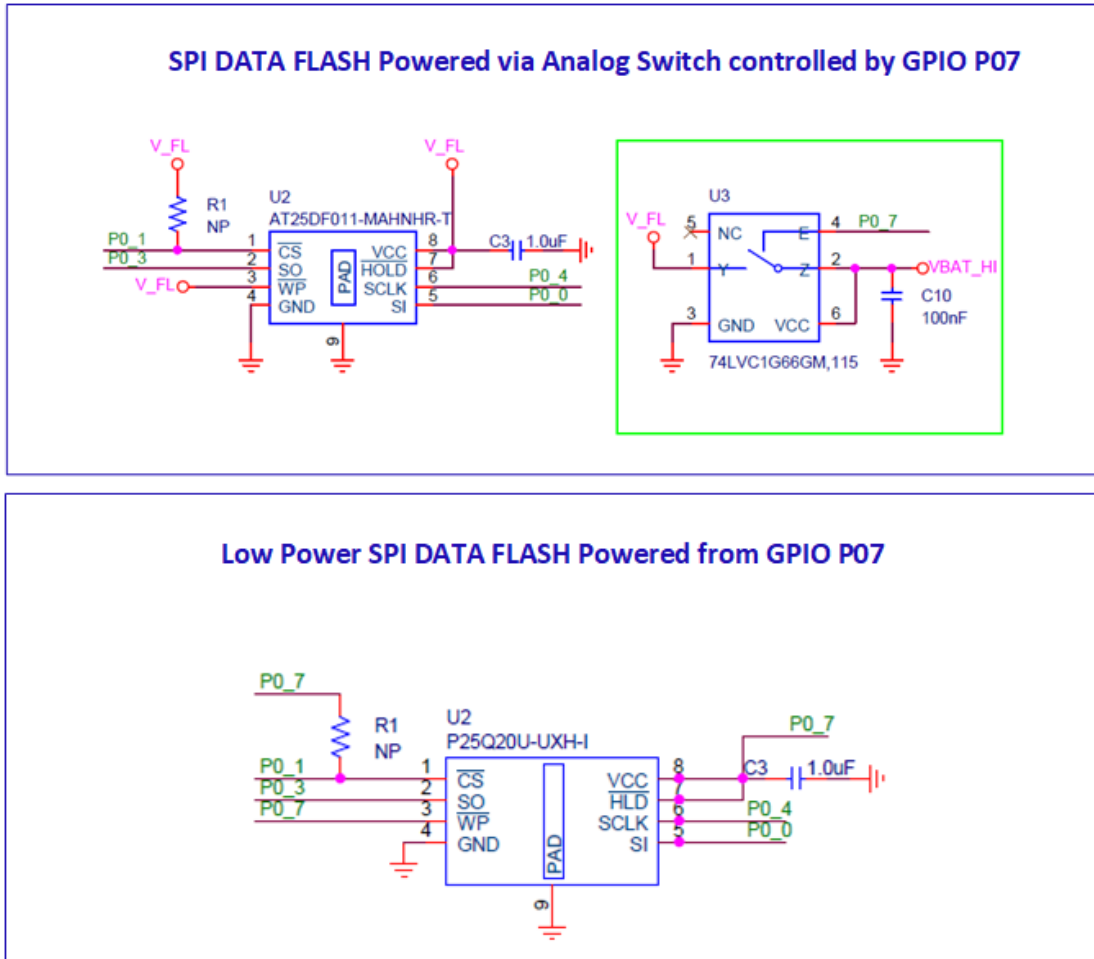

Figure 76: Using external power supply for 1.5V boost operation

### G.3 Important Notice For Boost Operation

For a guaranteed startup, the load on VBAT\_HIGH must not exceed 50  $\mu$ A during system startup/wake-up.

Load like SPI flash should be isolated from VBAT\_HIGH in order to avoid overloading the rail during boot. A dedicated GPIO pin can be used to provide power to an external flash memory either directly, if the current requirements are within the current sourcing capabilities of the pin, or through a load switch/power management IC. A secondary bootloader is necessary in order to support the powering up of the external flash. In Figure 77 possible implementations are given.



**Figure 77: Examples of SPI Flash power management using (top) analog switch (bottom) directly GPIO**

For more information regarding the boost operation and flash and secondary bootloader refer to [3] and [4].



**Revision History**

Revision	Date	Description
1.6	22-Feb-2022	Document rebranded to Renesas.
1.5	07-Jun-2021	Table 15: Typo correction for Buck, Bypass setting
1.4	23-Apr-2021	Section 2: References - Added missing url links Section 4.2.1: replaced broken url link for SMA connector Replaced Figures 1,4, 5, 7, 30, 56, 58, 61 Added Appendix G Various corrections
1.3	18-Sept-2020	Corrections on section 9.3, "mikroBUS wrong labels"
1.2	13-April-2020	Correction of J8 pin assignment.
1.1	24-Oct-2019	Editorial review.
1.0	15-Oct-2019	Initial version.