

TRIGGER DIODES

FEATURES

- * V_{BO} : 32V/34V/40V VERSIONS
- * Low Breakover Current

DESCRIPTION

- * Molded plastic-JEDEC DO214AC case
- * Built-in strain relief, ideal for Automated pick/place assembly
- * Weight: 0.064 grams



DO214AC(SMA)

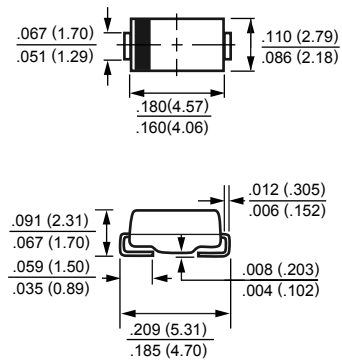

Dimensions in inches and (millimeters)

MAXIMUM RATINGS (At $T_A = 25^\circ\text{C}$ unless otherwise noted)

RATING	SYMBOL	VALUE	UNITS
Repetitive Peak On-State Current $t_p=20\mu\text{s}, F=100\text{Hz}$	I_{TRM}	2	A
Power Dissipation (@ $T_A=50^\circ\text{C}$)	P	150	mW
Derate Above $+50^\circ\text{C}$		4.0	mW/ $^\circ\text{C}$
Storage Temperature Range	T_{STG}	-40 to + 125	$^\circ\text{C}$
Junction Temperature	T_J	125	$^\circ\text{C}$

ELECTRICAL CHARACTERISTICS (At $T_A = 25^\circ\text{C}$ unless otherwise noted)

RATING	SYMBOL	VALUE				UNITS
		DB3W-1		DB3W-2		
Breakover Voltage(Forward and Reverse) at $I_{BO}, C=22\text{nF}^{**}$	V_{BO}	Min 30	Max 34	Min 28	Max 36	Volts
Maximum Breakover Voltage Symmetry $\Delta V_{BO} = V_{BO+} - V_{BO-} $ $C=22\text{nF}$	ΔV_{BO}	+/-2				Volts
Minimum Dynamic Breakover Voltage $\Delta I = I_{BO}$ to $I_F=10\text{mA}$ (see Fig3)	$ \Delta V_{+/-} $	5				Volts
Minimum Output Voltage* (see Fig 2)	V_O	5				Volts
Peak Breakover Current at Breakover Voltage* $C=22\text{nF}^{**}$	I_{BO}	25		100		μA
Rise Time* (see Fig3)	t_r	1.5				μs
Leakage Current* $V_B=0.5V_{BO}$ max (see Fig1)	I_B	10				μA

- NOTES: 1. *Electrical characteristic applicable in both forward and reverse directions.
 2.**Connected in parallel with the devices.
 3. "Fully ROHS compliant", "100% Sn plating (Pb-free)".

RATING AND CHARACTERISTICS CURVES (DB3W)



FIG.1 Current-voltage characteristics

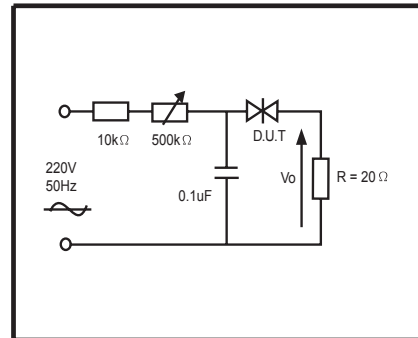

FIG.2 Test circuit for output voltage



FIG.3 Test circuit see Fig.2
Adjust R for $I_p=0.5\text{A}$

RATING AND CHARACTERISTICS CURVES (DB3W)

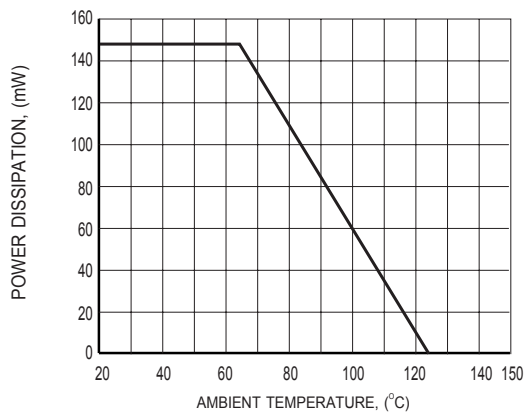

FIG.4 POWER DISSIPATION VERSUS AMBIENT TEMPERATURE (MAXIMUM VALUES)

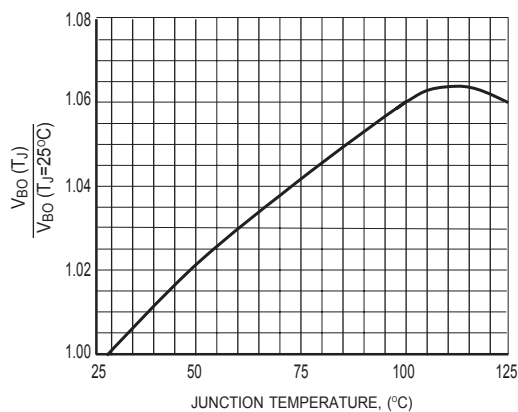

FIG.5 RELATIVE VARIATION OF V_{BO} VERSUS JUNCTION TEMPERATURE (TYPICAL VALUES)

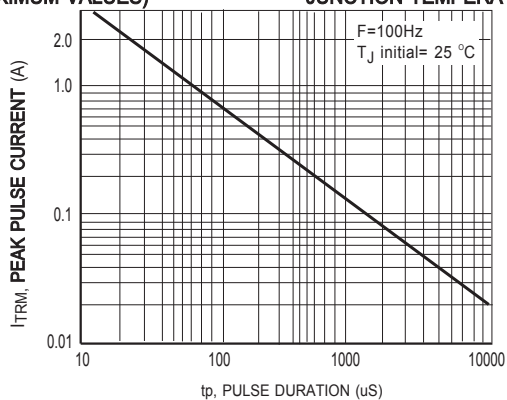

FIG.6 PEAK PULSE CURRENT VERSUS PULSE DURATION (MAXIMUM VALUES)

Mounting Pad Layout



Dimensions in inches and (millimeters)