

LTC4356-2 Overvoltage Protection Regulator

FEATURES

- For Automotive Applications up to 3A
- Triple Layout for D-Pak, D2-Pak or S-8 MOSFETs
- 0.093-inch Turret Holes Accommodate 12 AWG Wire
- LEDs Show Input, Outputs, Fault and Enable
- Easily Modified for up to 20A

APPLICATIONS

- Servers, Routers, Switches
- Mass Storage
- Fan Trays
- Automotive Modules

DESCRIPTION

Demonstration Circuit [DC1018B-B](#) showcases the LT4356-2 Surge Stopper in a 12V, 3A application. Input transients of up to 60V are limited to 16V at the output; sustained overvoltage conditions cause the limiter to trip off and retry after the overvoltage is removed.

LEDs indicate the presence of +12V input and output, as well as state of the fault output, FLT# and enable output, EN.

Input and output connections are made by 93 mil turrets which if removed, accommodate insertion of up to 12 gauge wires for in-situ testing.

[Design files for this circuit board are available.](#)

All registered trademarks and trademarks are the property of their respective owners.

PERFORMANCE SUMMARY Specifications are at T_A = 25°C

| SYMBOL | PARAMETER | CONDITIONS | MIN | TYP | MAX | UNITS |
|--------------------|-------------------------|---|------|-----|------|-------|
| V _{IN} | Input Operating Range | | 4 | 12 | 60 | V |
| | Peak Input Voltage | Clipped by Transient Voltage Suppressor | | | 100 | V |
| V _{LIMIT} | Output Limiting Voltage | | 15.3 | 16 | 16.7 | V |
| I _{OUT} | Maximum Load Current | | 3.5 | | | A |

QUICK START PROCEDURE

Board Layout

DC1018B-B is a 4-layer board. There are planes for input, output, drain and ground; these are replicated on each layer.

The spare amplifier is kept active during shutdown in the LT4356CDE-2, resulting in a supply current of about 50 μ A.

The 93 mil input and output connection turrets are not swaged and may be removed for attachment of up to 12 gauge wire. Banana jacks facilitate bench testing.

Sufficient copper is available to support applications of at least 20A.

LEDs are included as quick debug indicators. These LEDs show:

| | | |
|------|------------|-------|
| LED1 | 12V input | Green |
| LED3 | 12V output | Green |
| LED4 | FLT | Red |
| LED5 | EN | Green |

The enable and fault LEDs are both powered in such a way that the signals present on their associated turrets are limited in voltage (see schematic). To this end a simple series regulator (Q2 and D6) has been included on the demo board for powering the FLT# output; the FLT# pin itself is rated to 80V.

R8 is an optional pull-up resistor for the SHDN# pin.

Modifying Current Limit

DC1018B-B is designed for 3.5A maximum load current and may be modified for higher or lower current levels. Sense resistor RSNS1-3 pads are designed for 1206 or 2010 sense resistors. The LT4356-2 current sense voltage is 50mV, with limiting occurring at 50mV/RSNS. Optional footprints for D2-pak or S-8 MOSFETs allow for much higher or lower current levels. Sufficient copper is present to handle in excess of 20A. If the S-8 footprint is used, move R3 (10 ohms) to the bottom of the board, R3B. This is the gate resistor for the S-8 MOSFET.

At higher currents the clamp DCL must be proportionately increased. This catches the locally generated spike at the MOSFET drain when the output goes into regulation. The energy content of this spike is a direct function of input slew rate and output load capacitance.

Changing Output Regulation Level

The output limiting or regulation voltage is easily modified by simply changing R1 and R2 to values appropriate for the application. The FB pin servo voltage is 1.25V. See the data sheet for a full description of this pin and equations. As built, the demo board clamps at 16V.

The actual operating voltage is independent of the clamping volt-age, and may be anything from the minimum operating voltage of 4V up to the clamping voltage. Thus while the demo board is labeled “12V”, it can operate with any other sub-16V input such as a 5V regulated supply, a 6V gelcell, or a stack of 8 NiMH cells, or a 9V impedance limited wall cube, to name but a few possible inputs.

Supply Current

The low shutdown current of the LT4356-2 is impossible to measure on the demo board because of the presence of the input LED, LED1, and the LED Supply. Remove R10 and R17 to eliminate these paths.

Note that above 16V, D4 will draw current. Below 16V leakage in D4, Q2’s collector-base junction in series with D6 and Q1 will add to the LT4356-2’s supply current. These effects are insignificant at room temperature.

Small Turrets

No connection to any of the small turrets is necessary to make the board operate—the LT4356-2 defaults to the ON state.

SHDN# is pulled high internally. If this turret is left open, the board will turn on when power is applied. Short this turret to ground to turn off the LT4356-2.

QUICK START PROCEDURE

FLT# pulls low after a TMR interval if there is a sustained input overvoltage, and does so 2ms before the output shuts down. Otherwise FLT# is high, pulled up by LED4 and the 5V LED Supply.

EN is an output. It goes high when the 12V output rises to within 700mV of the input. EN is latched and does not pull low again until the LT4356-2 trips off from a sustained overvoltage or is shut down. EN is pulled up to the output through a 3.9kilo-ohm resistor, and is shunted by LED5. Use EN to enable downstream circuitry.

Input Overvoltages and Bench Testing

The LT4356-2 is designed to block transient voltages and surges from reaching load circuitry of limited voltage capability. This has a profound impact on the voltage rating of downstream components as well as topology where dc-to-dc converters are concerned, not to mention elimination of bulky input filter inductors and capacitors.

To this end, Q1 is selected for a 3A application where the surges and transients are consistent with an automotive environment.

Sustained dc overvoltage conditions are not part of the automotive environment, and in the standard circuit configuration, Q1 would likely overheat from continuous autoretry if, for example, 60Vdc was applied to the input. Yet a 60Vdc input is a likely event during initial bench testing.

An Overvoltage Lockout circuit has been included on the demo board to prevent MOSFET destruction during bench testing. This operates by pulling up on the TMR pin and preventing autoretry when the input voltage exceeds approximately 18V.

If the board is only subjected to surges and transients, the Overvoltage Lockout circuit is unnecessary and in fact plays a nuisance-to-nothing role. Remove R16 to defeat the Overvoltage Lockout circuit function.

DC1018B-B is designed to ride through input transients of 1 or 2ms duration, but will shut down during load dump. Q1 must dissipate significant energy to support a 3A load

during load dump, so a larger MOSFET is necessary if Q1 is to survive. CTMR must be increased to accommodate the proposed time interval if this modification is contemplated.

Locally Generated Drain Spikes

When an input transient waveform is applied to an operating LT4356-2, the MOSFET is fully on and a large magnitude displacement current flows into the load capacitors, CL1 and CL2 (collectively, CL) and any other off-board load capacitors. The LT4356-2 has a relatively soft current limit amplifier to prevent detection of current pulses generated by noise spikes. This soft response prevents the LT4356-2 from responding to the initial current surge in CL.

The current surge is limited only by the feedpoint impedance of the supply, the transient rising slew rate and the capacitance and ESR of CL. The current surge is commutated by the MOSFET once CL charges to Vgate-Vthreshold, and results in a wide-bandwidth voltage spike at the input, limited only by the breakdown of input clamp DCL. Without DCL the input voltage could easily exceed 100V and destroy the LT4356-2.

Under normal conditions (typical automotive transients and surges) the input rise time is 10 μ s or more, and the CL displacement current is moderate. Drain spikes are thereby limited in amplitude.

When bench testing, input rise times may easily reach 100ns creating an environment for destructive drain spikes, generated by the MOSFET itself.

To protect the LT4356-2 from damage during bench testing with fast-rising input edges, an SMAJ58A TransZorb has been chosen for diode clamp DCL. This component clamps the drain spike to less than 100V. The knee is around 64V. If a dc voltage higher than 60V is connected to DC1018B-B, DCL will be destroyed. Transients to 80V are permissible as the current in DCL will be limited by wiring inductance. Further, the energy is limited because the time spent in conduction by DCL is short.

QUICK START PROCEDURE

Basic Operation

Connect a 12V supply to input, and the load to output.

The circuit will turn on automatically when power is applied.

To test the voltage limiter, apply a transient to the 12V Input. One method of coupling a transient without back-feeding the 12V supply is shown in the Connection Diagram, attached. If the input transient is short the output simply limits at 16V and then recovers to 12V.

If the transient is sustained, the output will rise to 16V, regulate there and then shut down. The exact timing and the dividing line between “short” and “sustained” is a function of the input waveform amplitude and shape (see the data sheet). Once the input voltage falls below the Overvoltage Lockout level, autoretry is initiated after a cooldown period of 42.5ms. The timing intervals are controlled by CTMR and the TMR pin according to equations in the data sheet.

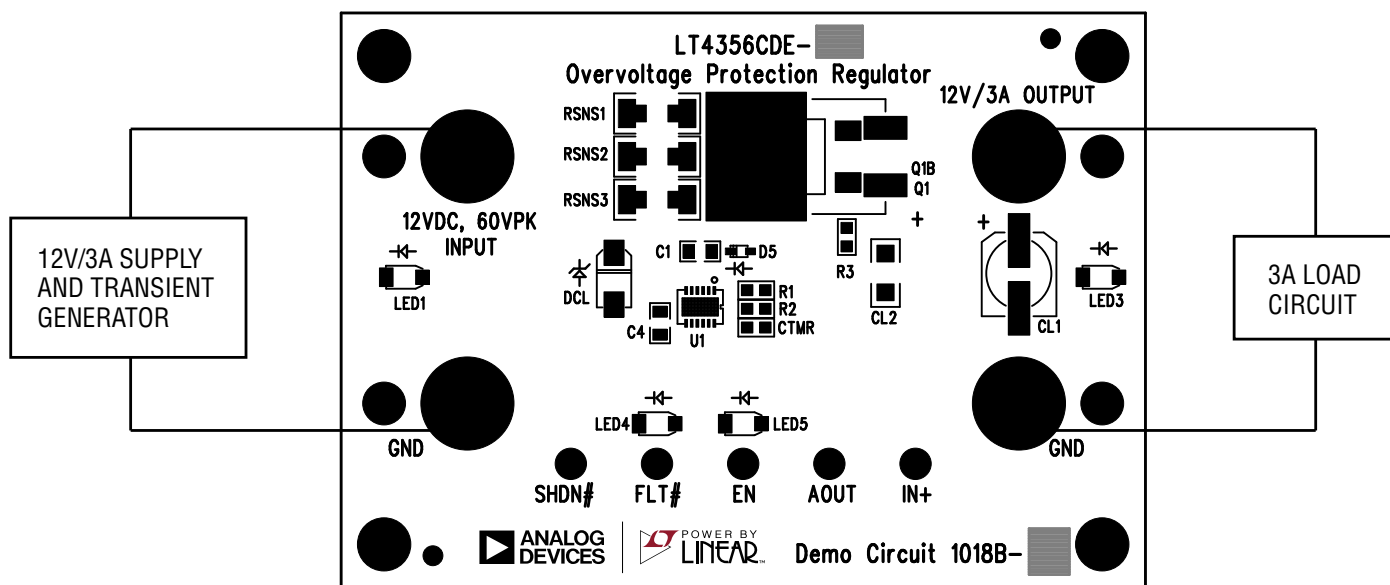

Figure 1. Proper Measurement Equipment Setup

SCHEMATIC DIAGRAM

