

DESCRIPTION

Demonstration circuit 1076 is a filter diplexer. This circuit facilitates bench evaluation of high speed analog to digital converters in an environment where coaxial cable length exists between the ADC input and any non-absorptive terminations such as bandpass filters that will reflect sampling impulses. Technically DC1076 is an absorptive filter, not a true diplexer. True diplexers will also work; the original development used a true diplexer,

hence the demo circuit name. However, a true diplexer of equivalent performance requires more parts and odd component values to achieve good crossover performance.

Design files for this circuit board are available. Call the LTC factory.

PowerPath is a trademark of Linear Technology Corporation

Table 1. Performance Summary ($T_A = 25^\circ\text{C}$)

PARAMETER	CONDITION	VALUE
LPF Bandwidth	3dB cutoff	$f > 150\text{MHz}$
Impedance		50Ω
Out of Band Return Loss	$f > f_{3\text{DB}}$	$> 20\text{dB}$

OPERATING PRINCIPLES

When transmission line length exists between reflective terminations and the input of a High speed ADC, the disturbance caused by the sample switches opening and closing reflect back and forth between the reflective termination and the ADC input. In a practical layout, this transmission line length is very short and the reflections damp out between sample clocks. In a bench evaluation environment, external connectorized filters and cables often must be introduced between signal sources and the ADC demonstration circuit board. This can easily introduce 100x more low loss transmission line length between the reflective termination of the filter and the ADC input. As a result, the sampling glitch disturbance does not completely dissipate in the circuit losses between sampling clock edges. This results in additional distortion products, particularly elevated harmonics in the ADC output. The DC1076 is an absorptive filter which when placed directly on the input to the ADC aids in attenuating the sample glitches and reducing the dis-

tortion products. The schematic for DC1076 is shown in Figure 1 and the layout in Figure 2, note that the filter is actually < 1.00 inch square. The sampling glitch exhibits very fast edges and therefore most of the frequency content is at higher harmonic frequencies. Figure 3 shows the filter response, S_{21} , and input and output return losses, S_{11} and S_{22} respectively of the DC1076 Filter Diplexer. Figure 4 shows the same parameters for a commercial 70MHz band pass filter, out of band energy is completely reflected back to the source. Figure 5 shows the cascaded response of the commercial filter with the DC1076. The combination provides the pass-band attribute of the 70MHz BPF while the return loss presented to the ADC (S_{22}) is 20dB in the upper stop band to beyond 1GHz. The source of course will still see complete reflection of out of band energy as S_{11} is $\cong 0\text{dB}$ outside the pass band of the 70MHz BPF.

QUICK START PROCEDURE

Demonstration circuit 1076 is easy to connect to a Linear Technology High Speed ADC board. The filter is provided with a Male SMA output connector which will directly connect to the input of the ADC demonstration circuit without any adaptors. The input is fitted with a Female SMA connector as used on the ADC demonstration circuits and so it can be connected in line without

any additional hardware. The filter provides a well-behaved low pass filter response with a wideband VSWR less than 1.25:1 or 20dB return loss to over 1GHz. It is suitable for use with input frequencies up to 150MHz before insertion loss and phase delay begin to compromise the input signal. For frequencies above this range, consult factory.

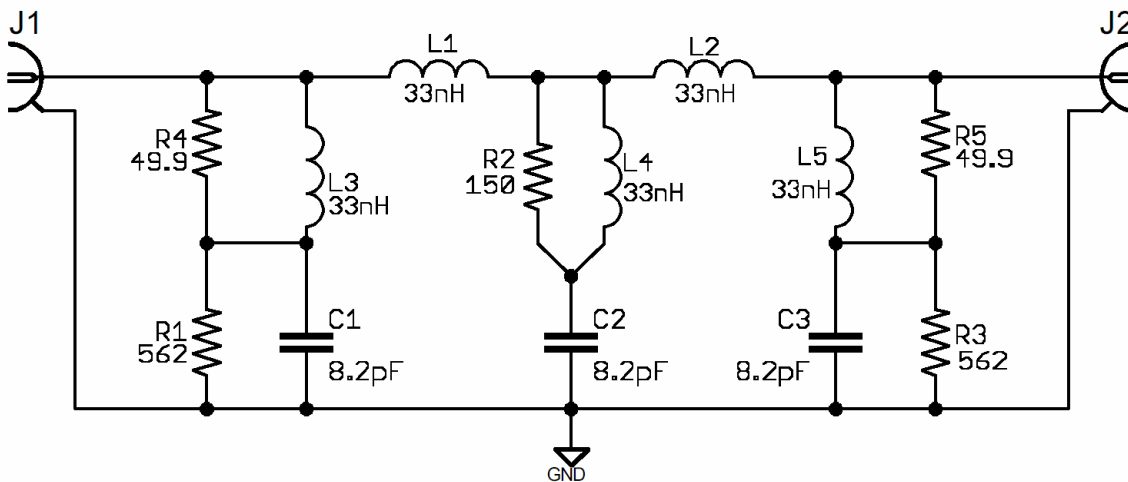

Figure 1. DC1076 Filter Diplexer Schematic

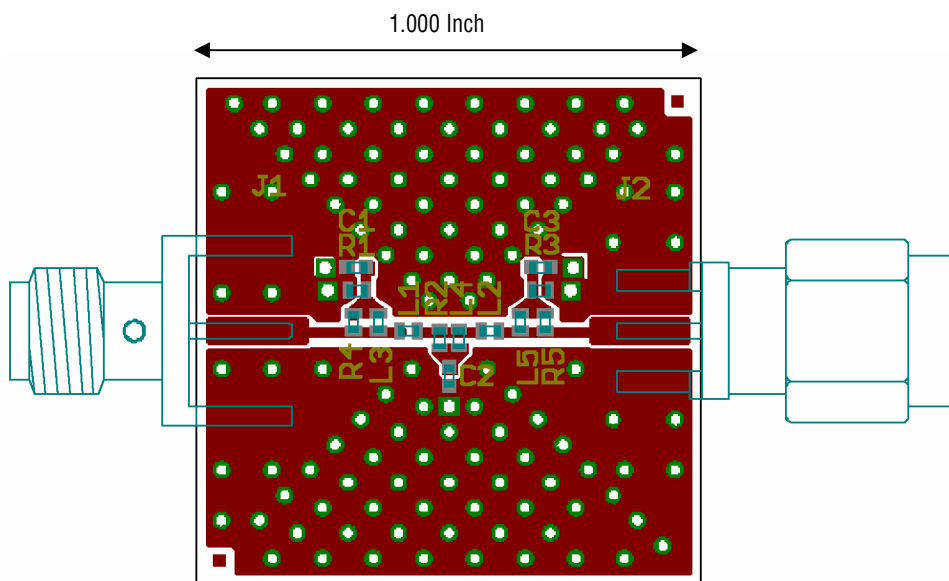

Figure 2. DC1076 Filter Diplexer Board