

FEATURES

- Two Independent Current Sense Amplifiers
- Wide Supply Range: 4V to 60V, 70V Absolute Maximum
- Low Offset Voltage: 450 μ V Maximum
- Fast Response: 1 μ s Response Time
- Gain Configurable with External Resistors
- Low Input Bias Current: 170nA Maximum
- PSRR: 110dB Minimum (6V to 60V)
- Output Current: 1mA Maximum
- Low Supply Current: 275 μ A per Amplifier, $V_S = 12$ V
- Specified for -40°C to 125°C Temperature Range
- Available in an 8-lead MSOP Package

APPLICATIONS

- Current Shunt Measurement
- Battery Monitoring
- Remote Sensing
- Power Management
- High Voltage Level Translator

DESCRIPTION

The LTC[®]6103 is a versatile, high voltage, high side, dual current sense amplifier. The two internal amplifiers are independent except that they share the same V^- terminal. Design flexibility is provided by the excellent device characteristics: 450 μ V maximum offset, and only 275 μ A of current consumption (typical at 12V) for each amplifier. The LTC6103 operates on supplies from 4V to 60V.

The LTC6103 monitors current via the voltage across an external sense resistor (shunt resistor). Internal circuitry converts input voltage to output current, allowing for a small sense signal on a high common mode voltage to be translated into a ground referenced signal. Low DC offset allows the use of a small shunt resistor and large gain-setting resistors. As a result, power loss in the shunt is minimal.

The wide operating supply range and high accuracy make the LTC6103 ideal for an extensive variety of applications from automotive to industrial and power management. The fast response makes the LTC6103 the perfect choice for load current warnings and shutoff protection control. With very low supply current, the LTC6103 is suitable for power sensitive applications.

The LTC6103 is available in an 8-lead MSOP package.

LT, LT, LTC and LTM are registered trademarks of Linear Technology Corporation. All other trademarks are the property of their respective owners.

TYPICAL APPLICATION

Two 16-Bit Current Sense Channels Connected Directly to the LTC2436-1 ADC

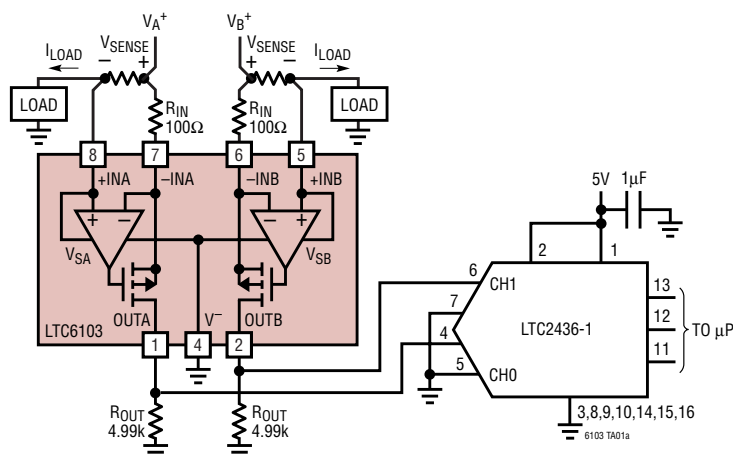

Step Response

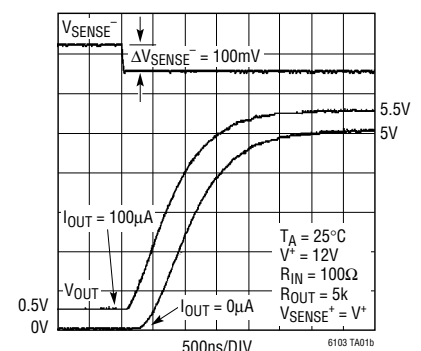

ABSOLUTE MAXIMUM RATINGS

(Note 1)

Total Supply Voltage (+INA/+INB to V ⁻)	70V
Maximum Applied Output Voltage (OUTA/OUTB)	9V
Input Current	±10mA
Output Short-Circuit Duration (to V ⁻)	Indefinite
Operating Temperature Range	
LTC6103C	-40°C to 85°C
LTC6103I	-40°C to 85°C
LTC6103H	-40°C to 125°C
Specified Temperature Range (Note 2)	
LTC6103C	0°C to 70°C
LTC6103I	-40°C to 85°C
LTC6103H	-40°C to 125°C
Storage Temperature Range	-65°C to 150°C
Lead Temperature (Soldering, 10 sec)	300°C

PACKAGE/ORDER INFORMATION

<p style="text-align: center;">TOP VIEW</p> <p style="text-align: center;">MS8 PACKAGE 8-LEAD PLASTIC MSOP T_{JMAX} = 150°C, θ_{JA} = 300°C/W</p>	
ORDER PART NUMBER	MS8 PART MARKING*
LTC6103CMS8	LTCMN
LTC6103IMS8	LTCMN
LTC6103HMS8	LTCMN
Order Options Tape and Reel: Add #TR Lead Free: Add #PBF Lead Free Tape and Reel: Add #TRPBF Lead Free Part Marking: http://www.linear.com/leadfree/	

Consult LTC Marketing for parts specified with wider operating temperature ranges.
*The temperature grade is identified by a label on the shipping container.

ELECTRICAL CHARACTERISTICS

The ● denotes the specifications which apply over the full operating temperature range, otherwise specifications are at T_A = 25°C. R_{IN} = 100Ω, R_{OUT} = 5k, 4V ≤ +INA/+INB ≤ 60V, V⁻ = 0V unless otherwise noted.

SYMBOL	PARAMETER	CONDITIONS	MIN	TYP	MAX	UNITS
+INA(V _{SA})/+INB(V _{SB})	Supply Voltage Range		●	4	60	V
V _{OS}	Input Offset Voltage	V _{SENSE} = 5mV, LTC6103 V _{SENSE} = 5mV, LTC6103C, LTC6103I V _{SENSE} = 5mV, LTC6103H	●	±85	±450 ±600 ±700	μV μV μV
ΔV _{OS} /ΔT	Input Offset Voltage Drift	V _{SENSE} = 5mV	●	±1.5		μV/°C
I _B	Input Bias Current	R _{IN} = 1M to -INA and -INB	●	100	170 245	nA nA
PSRR	Power Supply Rejection Ratio	+INA/+INB = 6V to 60V, V _{SENSE} = 5mV	●	110 106	120	dB dB
		+INA/+INB = 4V to 60V, V _{SENSE} = 5mV	●	105 98	115	dB dB
V _{OUT(MAX)}	Maximum Output Voltage	12V ≤ +INA/+INB ≤ 60V, V _{SENSE} = 88mV, R _{OUT} = 10k	●	8		V
		+INA/+INB = 6V, V _{SENSE} = 66mV, R _{OUT} = 5k	●	3		V
		+INA/+INB = 4V, V _{SENSE} = 55mV, R _{OUT} = 2k	●	1		V
V _{OUT(0)}	Minimum Output Voltage (Note 3)	V _{SENSE} = 0V, LTC6103	●	0	22.5	mV
		V _{SENSE} = 0V, LTC6103C, LTC6103I	●		30	mV
		V _{SENSE} = 0V, LTC6103H	●		35	mV
I _{OUT(MAX)}	Maximum Output Current	6V ≤ +INA/+INB ≤ 60V, V _{SENSE} = 110mV, R _{OUT} = 2k	●	1		mA
		+INA/+INB = 4V, V _{SENSE} = 55mV, R _{OUT} = 2k, Gain = 20	●	0.5		mA
t _r	Input Step Response (to 50% of Output Step)	ΔV _{SENSE} = 100mV Step, 6V ≤ +INA/+INB ≤ 60V		1		μs
		+INA/+INB = 4V (1V Output Step), R _{OUT} = 1k		1.5		μs
BW	Signal Bandwidth	I _{OUT} = 200μA, R _{IN} = 100Ω, R _{OUT} = 5k		120		kHz
		I _{OUT} = 1mA, R _{IN} = 100Ω, R _{OUT} = 5k		140		kHz

ELECTRICAL CHARACTERISTICS

The ● denotes the specifications which apply over the full operating temperature range, otherwise specifications are at $T_A = 25^\circ\text{C}$. $R_{IN} = 100\Omega$, $R_{OUT} = 5k$, $4V \leq +INA/+INB \leq 60V$, $V^- = 0V$ unless otherwise noted.

SYMBOL	PARAMETER	CONDITIONS	MIN	TYP	MAX	UNITS
I_{+INA}, I_{+INB}	Supply Current per Amplifier	+INA/+INB = 4V, $I_{OUT} = 0$, $R_{IN} = 1M$	●	220	450 475	μA μA
		+INA/+INB = 6V, $I_{OUT} = 0$, $R_{IN} = 1M$	●	255	475 525	μA μA
		+INA/+INB = 12V, $I_{OUT} = 0$, $R_{IN} = 1M$	●	275	500 590	μA μA
		+INA/+INB = 60V, $I_{OUT} = 0$, $R_{IN} = 1M$ LTC6103I, LTC6103C LTC6103H	● ●	390	640 690 720	μA μA μA

Note 1: Stresses beyond those listed under Absolute Maximum Ratings may cause permanent damage to the device. Exposure to any Absolute Maximum Rating condition for extended periods may affect device reliability and lifetime.

Note 2: The LTC6103C is guaranteed to meet specified performance from 0°C to 70°C . The LTC6103C is designed, characterized and

expected to meet specified performance from -40°C to 85°C but is not tested or QA sampled at these temperatures. LTC6103I is guaranteed to meet specified performance from -40°C to 85°C . The LTC6103H is guaranteed to meet specified performance from -40°C to 125°C .

Note 3: This parameter is not tested in production and is guaranteed by the V_{OS} test.

TYPICAL PERFORMANCE CHARACTERISTICS

Input V_{OS} vs Temperature

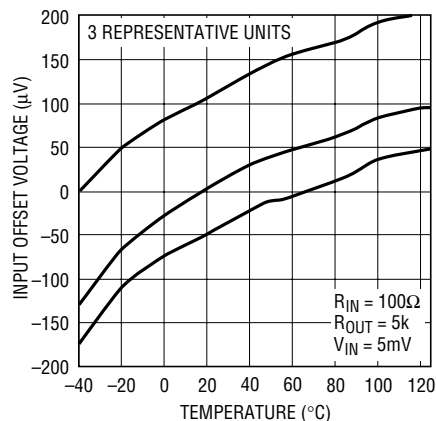

6103 G01

Input V_{OS} vs Supply Voltage

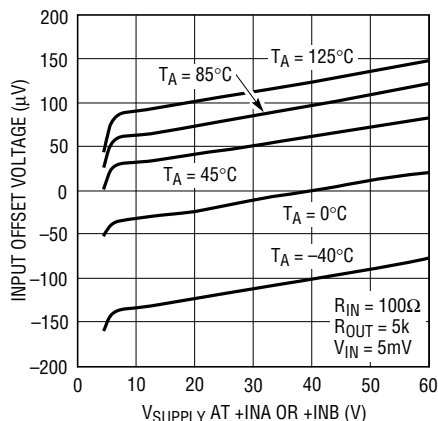

6103 G02

Input Sense Range

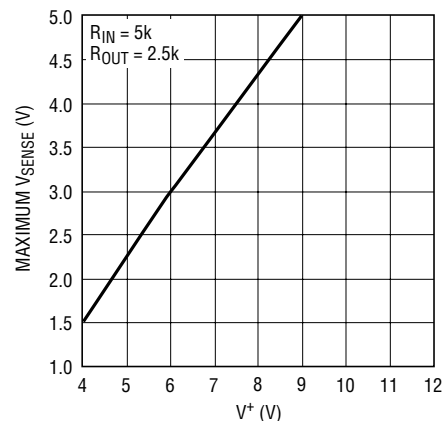

6103 G03

TYPICAL PERFORMANCE CHARACTERISTICS

V_{OUT} Maximum vs Temperature

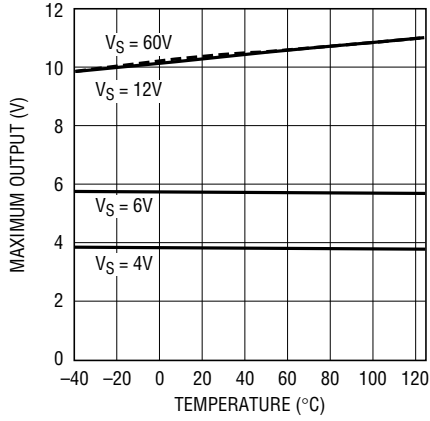

6103 G04

I_{OUT} Maximum vs Temperature

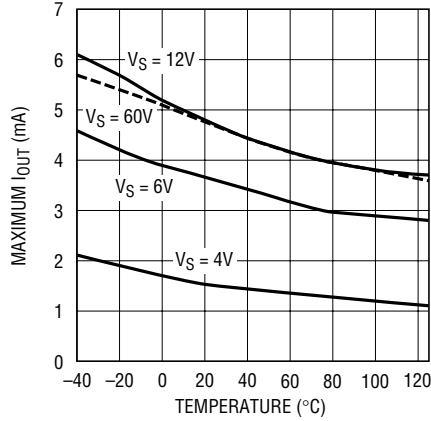

6103 G05

Calculated Output Error Due to Input Offset vs Input Voltage

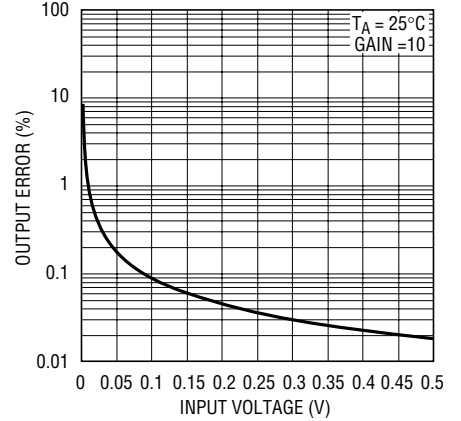

6103 G06

Gain vs Frequency

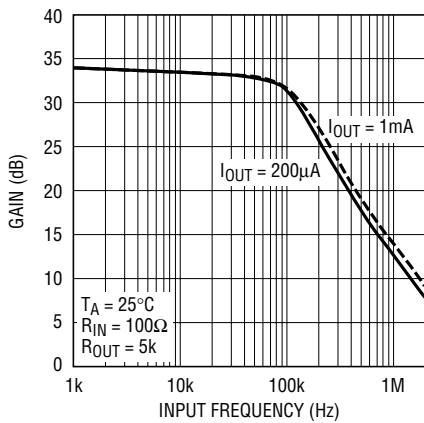

6103 G08

Input Bias Current vs Temperature

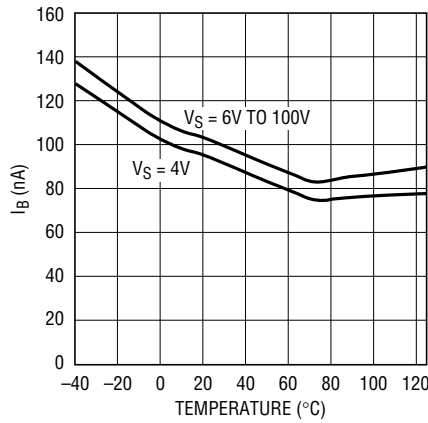

6103 G09

Supply Current vs Supply Voltage

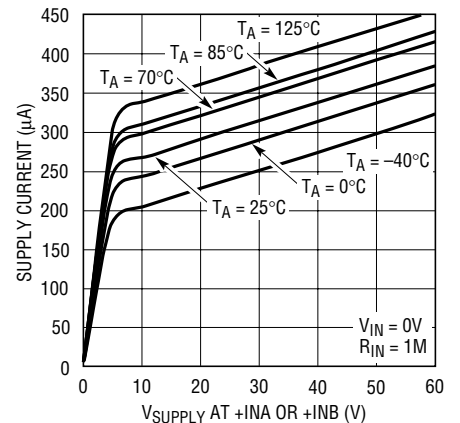

6103 G10

Step Response 0mV to 10mV

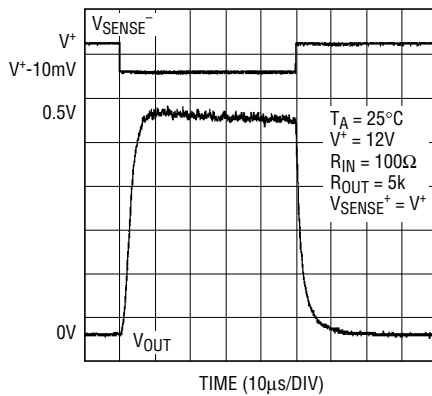

6103 G11

Step Response 10mV to 20mV

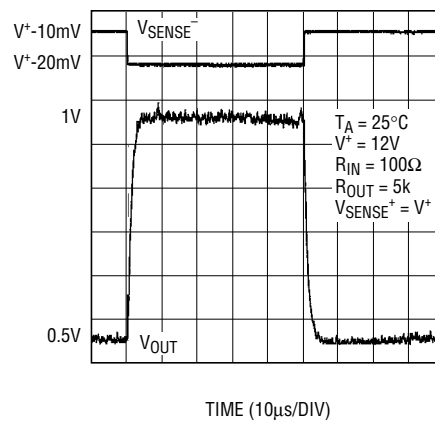

6103 G12

TYPICAL PERFORMANCE CHARACTERISTICS

Step Response 0mV to 100mV

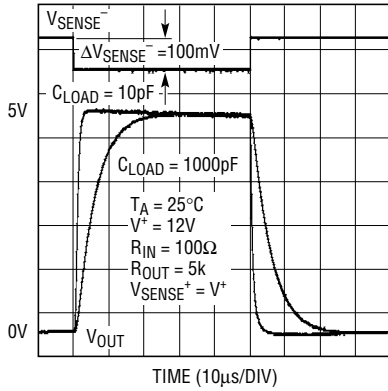

6103 G13

Step Response 0mV to 100mV

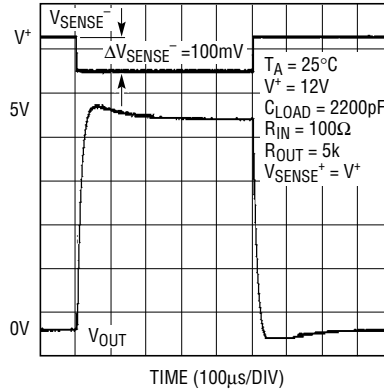

6103 G14

Step Response Rising Edge

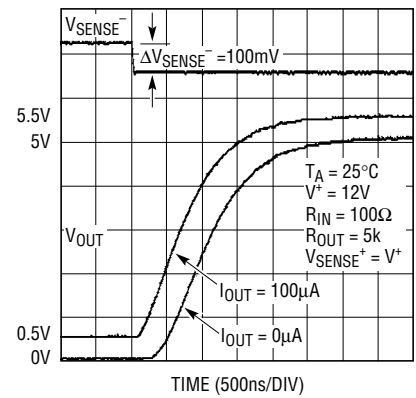

6103 G15

Step Response Falling Edge

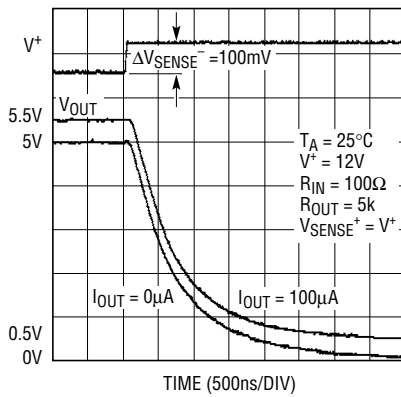

6103 G16

PSRR vs Frequency

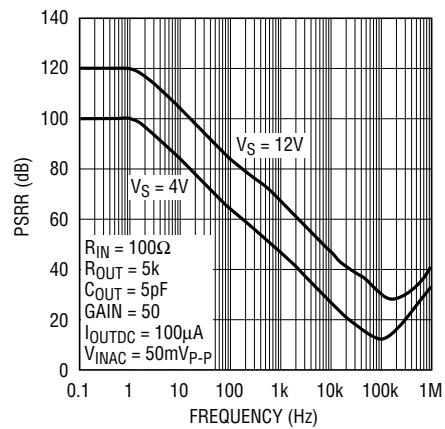

6103 G17

PIN FUNCTIONS

OUTA (Pin 1): Current Output of Amplifier A. OUTA will source a current that is proportional to the sense voltage of amplifier A into an external resistor.

OUTB (Pin 2): Current Output of Amplifier B. OUTB will source a current that is proportional to the sense voltage of amplifier B into an external resistor.

NC (Pin 3): No Connect.

V⁻ (Pin 4): Negative Supply (or Ground for Single Supply Operation). Common to both amplifiers.

+INB/V_{SB} (Pin 5): The Positive Input of the Internal Sense Amplifier B. Must be tied to the system load end of the sense resistor. It also works as the positive supply for amplifier B. Supply current of amplifier B is drawn through this pin. **The LTC6103 supply current is monitored along with the system load current.**

-INB (Pin 6): The Negative Input of the Internal Sense Amplifier B. The internal sense amplifier will drive -INB to the same potential as +INB. A resistor (R_{IN}) tied from V_B^+ to -INB sets the output current $I_{OUT} = V_{SENSE} / R_{IN}$. V_{SENSE} is the voltage developed across the external R_{SENSE} (Figure 1).

-INA (Pin 7): The Negative Input of the Internal Sense Amplifier A. The internal sense amplifier will drive -INA to the same potential as +INA. A resistor (R_{IN}) tied from V_A^+ to -INA sets the output current $I_{OUT} = V_{SENSE} / R_{IN}$. V_{SENSE} is the voltage developed across the external R_{SENSE} (Figure 1).

+INA/V_{SA} (Pin 8): The Positive Input of the Internal Sense Amplifier A. Must be tied to the system load end of the sense resistor. It also works as the positive supply for amplifier A. Supply current of amplifier A is drawn through this pin. **The LTC6103 supply current is monitored along with the system load current.**

BLOCK DIAGRAM

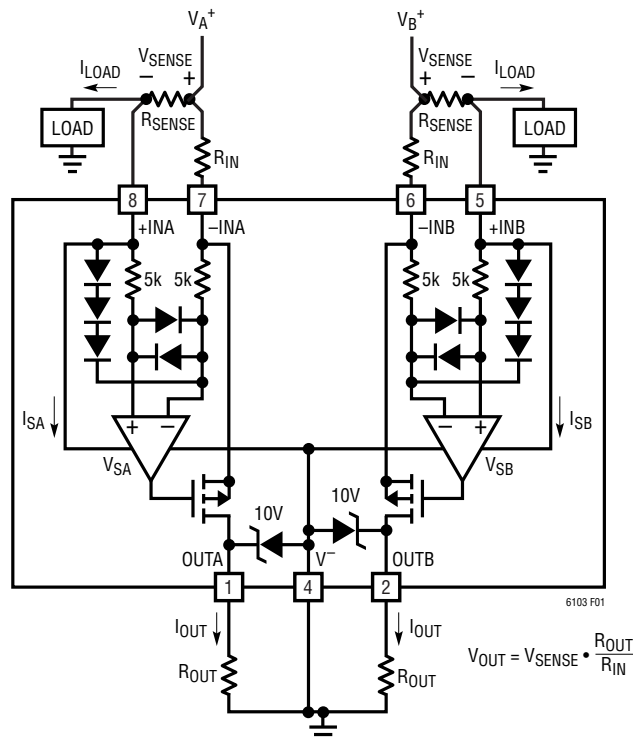

Figure 1. LTC6103 Block Diagram and Typical Connection

THEORY OF OPERATION

An internal sense amplifier loop forces $-IN$ to have the same potential as $+IN$. Connecting an external resistor, R_{IN} , between $-IN$ and V^+ forces a potential across R_{IN} that is the same as the sense voltage across R_{SENSE} . A corresponding current, $(I_{LOAD} + I_S) \cdot R_{SENSE}/R_{IN}$, will flow through R_{IN} . The high impedance inputs of the sense amplifier will not conduct this input current, so the current will flow through

an internal MOSFET to the OUT pin. In most application cases, $I_S \ll I_{LOAD}$, so $I_{OUT} \approx I_{LOAD} \cdot R_{SENSE}/R_{IN}$.

The output current can be transformed into a voltage by adding a resistor from OUT to V^- . The output voltage is then $V_{OUT} = (V^-) + (I_{OUT} \cdot R_{OUT})$.

APPLICATIONS INFORMATION

In this dual current sense device, amplifiers A and B are independent except for sharing the same V^- pin. So supply voltage and component values can be chosen independently for each amplifier.

Selection of External Current Sense Resistor

The external sense resistor, R_{SENSE} , has a significant effect on the function of a current sensing system and must be chosen with care.

First, the power dissipation in the resistor should be considered. The system load current will cause both heat and voltage loss in R_{SENSE} . As a result, the sense resistor should be as small as possible while still providing the input dynamic range required by the measurement. Note that input dynamic range is the difference between the maximum input signal and the minimum accurately reproduced signal, and is limited primarily by input DC offset of the internal amplifier of the LTC6103.

As an example, an application may require that the maximum sense voltage be 100mV. If this application is expected to draw 2A at peak load, R_{SENSE} should be no larger than 50m Ω .

$$R_{SENSE} = \frac{V_{SENSE}}{I_{PEAK}} = \frac{100\text{mV}}{2\text{A}} = 50\text{m}\Omega$$

Once the maximum R_{SENSE} value is determined, the minimum sense resistor value will be set by the resolution or dynamic range required. The minimum signal that can be accurately represented by this sense amp is limited by the input offset. As an example, the LTC6103 has a typical input offset of 85 μ V. If the minimum current is 20mA, a sense resistor of 4.25m Ω will set V_{SENSE} to 85 μ V. This is the same value as the input offset. A larger sense resistor will reduce the error due to offset by increasing the sense voltage for a given load current.

Choosing a 50m Ω R_{SENSE} will maximize the dynamic range and provide a system that has 100mV across the sense resistor at peak load (2A), while input offset causes an error equivalent to only 1.7mA of load current.

Peak dissipation is 200mW. If instead a 5m Ω sense resistor is employed, then the effective current error is 17mA, while the peak sense voltage is reduced to 10mV at 2A, dissipating only 20mW.

The low offset and corresponding large dynamic range of the LTC6103 make it more flexible than other solutions in this respect. The 85 μ V typical offset gives 60dB of dynamic range for a sense voltage that is limited to 85mV max, and over 75dB of dynamic range for a maximum input of 500mV.

APPLICATIONS INFORMATION

Sense Resistor Connection

Kelvin connections should be used between the inputs (+IN and –IN) and the sense resistor in all but the lowest power applications. Solder connections and PC board interconnections that carry high current can cause significant error in measurement due to their relatively large resistances. One 10mm × 10mm square trace of one-ounce copper is approximately 0.5mΩ. A 1mV error can be caused by as little as 2A flowing through this small interconnect. This will cause a 1% error in a 100mV signal. A 10A load current in the same interconnect will cause a 5% error for the same 100mV signal. By isolating the sense traces from the high current paths, this error can be reduced by orders of magnitude. A sense resistor with integrated Kelvin sense terminals will give the best results. Figure 2 illustrates the recommended method.

Selection of External Input Resistor, R_{IN}

The external input resistor, R_{IN}, controls the transconductance of the current sense circuit. Since:

$$I_{OUT} = \frac{V_{SENSE}}{R_{IN}}, \text{ transconductance } g_m = \frac{1}{R_{IN}}$$

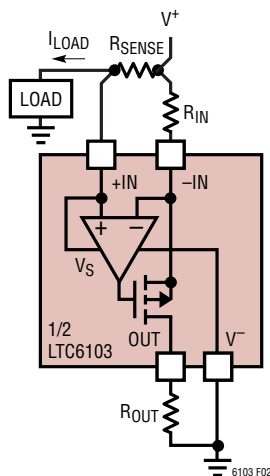

Figure 2. Kelvin Input Connection Preserves Accuracy Despite Large Load Current

For example, if R_{IN} = 100Ω, then:

$$I_{OUT} = \frac{V_{SENSE}}{100\Omega}$$

or I_{OUT} = 1mA for V_{SENSE} = 100mV.

R_{IN} should be chosen to allow the required resolution while limiting the output current. At low supply voltage, I_{OUT} may be as much as 1mA. By setting R_{IN} such that the largest expected sense voltage gives I_{OUT} = 1mA, then the maximum output dynamic range is available. Output dynamic range is limited by both the maximum allowed output current and the maximum allowed output voltage, as well as the minimum practical output signal. If less dynamic range is required, then R_{IN} can be increased accordingly, reducing the maximum output current and power dissipation. If low sense currents must be resolved accurately in a system that has very wide dynamic range, a smaller R_{IN} than the maximum current specification allows may be used if the maximum current is limited in another way, such as with a Schottky diode across R_{SENSE} (Figure 3a). This will reduce the high current measurement accuracy by limiting the result, while increasing the low current measurement resolution.

This approach can be helpful in cases where occasional large burst currents may be ignored. It can also be used in a multi-range configuration where a low current circuit is added to a high current circuit (Figure 3b). Note that a comparator (LTC1540) is used to select the range, and transistor M1 limits the voltage across R_{SENSE(LO)}.

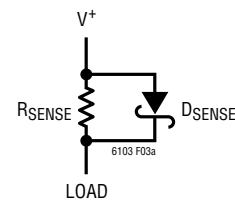

Figure 3a. Shunt Diode Limits Maximum Input Voltage to Allow Better Low Input Resolution Without Overranging

APPLICATIONS INFORMATION

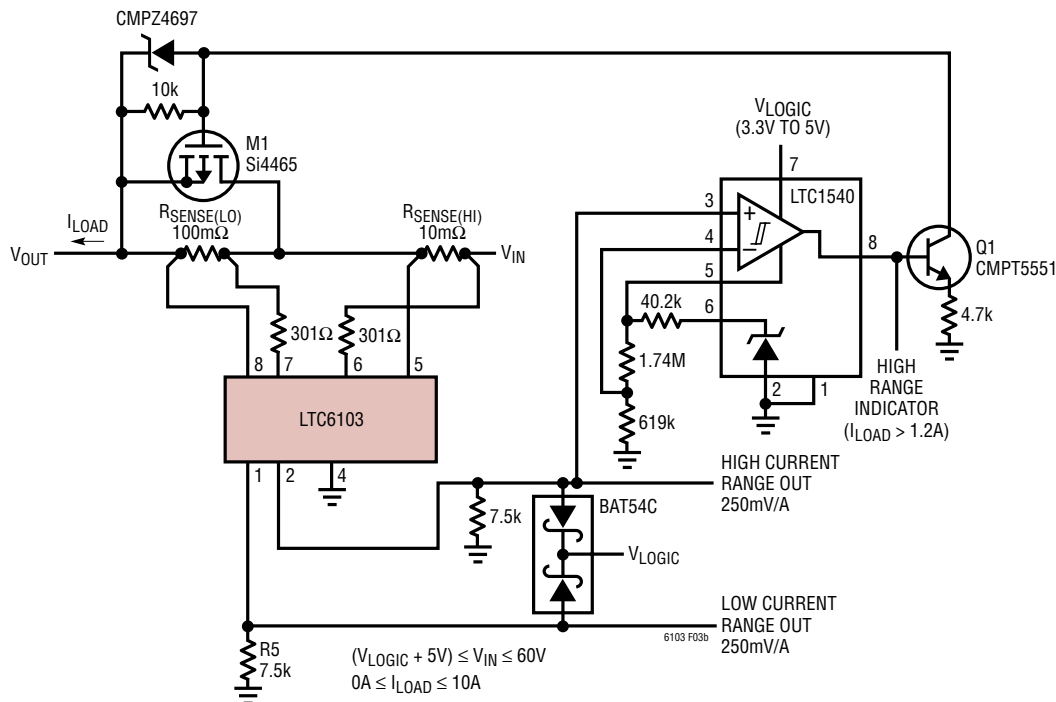

Figure 3b. The LTC6103 Allows High-Low Current Ranging

Care should be taken when designing the printed circuit board layout to minimize input trace resistance (to Pins 5, 6, 7 and 8), especially for small R_{IN} values. Trace resistance to the $-IN$ terminals will increase the effective R_{IN} value, causing a gain error. Trace resistance on $+IN$ terminals will have an effect on offset error. These errors are described in more detail later in this data sheet. In addition, internal device resistance will add approximately 0.3Ω to R_{IN} .

Selection of External Output Resistor, R_{OUT}

The output resistor, R_{OUT} , determines how the output current is converted to voltage. V_{OUT} is simply $I_{\text{OUT}} \cdot R_{\text{OUT}}$. In choosing an output resistor, the maximum output voltage must first be considered. If the circuit following is a buffer or ADC with limited input range, then R_{OUT} must be chosen so that $I_{\text{OUT(MAX)}} \cdot R_{\text{OUT}}$ is less than the allowed maximum input range of this circuit.

In addition, the output impedance is determined by R_{OUT} . If the circuit to be driven has high enough input impedance, then almost any useful output impedance will be acceptable. However, if the driven circuit has relatively low input impedance or draws spikes of current, as an ADC might do, then a lower R_{OUT} value may be required in order to preserve the accuracy of the output. As an example, if the input impedance of the driven circuit is 100 times R_{OUT} , then the accuracy of V_{OUT} will be reduced by 1% since:

$$\begin{aligned}
 V_{\text{OUT}} &= I_{\text{OUT}} \cdot \frac{R_{\text{OUT}} \cdot R_{\text{IN(DRIVEN)}}}{R_{\text{OUT}} + R_{\text{IN(DRIVEN)}}} \\
 &= I_{\text{OUT}} \cdot R_{\text{OUT}} \cdot \frac{100}{101} = 0.99 \cdot I_{\text{OUT}} \cdot R_{\text{OUT}}
 \end{aligned}$$

APPLICATIONS INFORMATION

Error Sources

The current sense system uses an amplifier and resistors to apply gain and level shift the result. The output is then dependent on the characteristics of the amplifier, such as bias current and input offset, as well as resistor matching. Ideally, the circuit output is:

$$V_{OUT} = V_{SENSE} \cdot \frac{R_{OUT}}{R_{IN}}$$

$$V_{SENSE} = R_{SENSE} \cdot I_{SENSE}$$

In this case, the only error is due to resistor mismatch, which provides an error in gain only. However, offset voltage, bias current and finite gain in the amplifier cause additional errors.

Output Error, E_{OUT} , Due to the Amplifier DC Offset Voltage, V_{OS}

$$E_{OUT(VOS)} = V_{OS} \cdot \frac{R_{OUT}}{R_{IN}}$$

The DC offset voltage of the amplifier adds directly to the value of the sense voltage, V_{SENSE} . This is the dominant error of the system and it limits the available dynamic range. The paragraph, Selection of External Current Sense Resistor provides details.

Output Error, E_{OUT} , Due to Bias Currents

The bias current $I_B(+)$ flows into the positive input of the internal op amp. $I_B(-)$ flows into the negative input.

$$E_{OUT(IBIAS)} = R_{OUT}(I_B(+)) \cdot (R_{SENSE}/R_{IN}) - I_B(-)$$

Since $I_B(+)$ \approx $I_B(-)$ = I_{BIAS} , if $R_{SENSE} \ll R_{IN}$ then:

$$E_{OUT(IBIAS)} \approx -R_{OUT} \cdot I_{BIAS}$$

For instance, if I_{BIAS} is 100nA and R_{OUT} is 1k, then the output error is 0.1mV.

Output Error, E_{OUT} , Due to PCB Trace Resistance

The LTC6103 uses the +IN pin for both the positive amplifier input and the positive supply input for the amplifier. The

supply current can cause an output error if trace resistance between R_{SENSE} and +IN is significant (Figure 4).

$$E_{OUT(RT_{+IN})} = (I_S \cdot R_T/R_{IN}) \cdot R_{OUT}$$

Trace resistance to the -IN pin will increase the effective R_{IN} value, causing a gain error. In addition, internal device resistance will add approximately 0.3Ω to R_{IN} .

Minimizing the trace resistance is important and care should be taken in the PCB layout. Make the trace short and wide. Kelvin connection to the shunt resistor pad should be used.

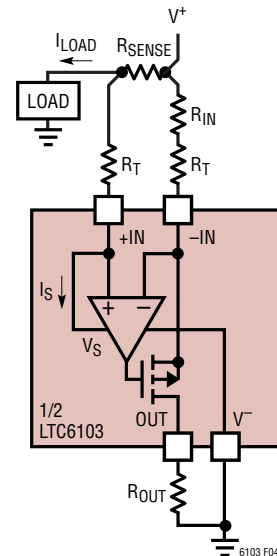

Figure 4. Error Due to PCB Trace Resistance

Output Error, E_{OUT} , Due to the Finite DC Open-Loop Gain, A_{OL} , of the LTC6103 Amplifier

This error is inconsequential as the A_{OL} of the LTC6103 is very large.

Design Example:

If I_{SENSE} range = (1A to 1mA) and:

$$\frac{V_{OUT}}{I_{SENSE}} = \frac{3V}{1A}$$

APPLICATIONS INFORMATION

If the power dissipation of the sense resistor is chosen to be less than 0.5W then:

$$R_{\text{SENSE}} \leq \frac{500\text{mW}}{I_{\text{SENSE(MAX)}}^2} = 500\text{m}\Omega$$

$$V_{\text{SENSE(MAX)}} = I_{\text{SENSE(MAX)}} \cdot R_{\text{SENSE}} = 500\text{mV}$$

$$\text{Gain} = \frac{R_{\text{OUT}}}{R_{\text{IN}}} = \frac{V_{\text{OUT(MAX)}}}{V_{\text{SENSE(MAX)}}} = \frac{3\text{V}}{500\text{mV}} = 6$$

If the maximum output current, I_{OUT} , is limited to 1mA:

$$R_{\text{OUT}} = \frac{3\text{V}}{1\text{mA}} \approx 3.01\text{k} \text{ (1\% value) and}$$

$$R_{\text{IN}} = \frac{3\text{k}}{6} \approx 499\Omega \text{ (1\% value)}$$

The output error due to DC offset is $\pm 510\mu\text{V}$ (typ) and the error due to offset current:

$$I_{\text{OS}} \text{ is } 3\text{k}\Omega \times 100\text{nA} = \pm 300\mu\text{V} \text{ (typical)}$$

The maximum output error can therefore reach $\pm 810\mu\text{V}$ or 0.027% (-71dB) of the output full scale. Considering the system input 60dB dynamic range ($I_{\text{SENSE}} = 1\text{mA}$ to 1A), the 71dB performance of the LTC6103 makes this application feasible.

In many applications the power dissipation of the sense resistor is of greater importance than the precision of the measurement. Designing for a $V_{\text{SENSE(MAX)}}$ of as low as 100mV is recommended in such cases.

Output Current Limitations Due to Power Dissipation

The LTC6103 can deliver up to 1mA continuous current to the output pin. This current flows through R_{IN} and enters the current sense amp via the $-I_{\text{N}}$ pin. The power dissipated in the LTC6103 due to the output signal is:

$$P_{\text{OUT}} = (V_{\text{IN}^-} - V_{\text{OUT}}) \cdot I_{\text{OUT}}$$

$$\text{Since } V_{\text{IN}^-} \approx V_{\text{S}}, P_{\text{OUT}} \approx (V_{\text{S}} - V_{\text{OUT}}) \cdot I_{\text{OUT}}$$

There is also power dissipated due to the quiescent supply current:

$$P_{\text{Q}} = I_{\text{S}} \cdot V_{\text{S}}$$

The total power dissipated is the output dissipation plus the quiescent dissipation:

$$P_{\text{TOTAL}} = P_{\text{OUTA}} + P_{\text{OUTB}} + P_{\text{QA}} + P_{\text{QB}}$$

At maximum supply and maximum output current, the total power dissipation can exceed 100mW. This will cause significant heating of the LTC6103 die. In order to prevent damage to the LTC6103, the maximum expected dissipation in each application should be calculated. This number can be multiplied by the θ_{JA} value listed in the Package/Order Information to find the maximum expected die temperature. This must not be allowed to exceed 150°C or performance may be degraded.

As an example, if an LTC6103 in the MS8 package is to be run at $55\text{V} \pm 5\text{V}$ supply with 0.5mA output current in both amplifiers at 80°C :

$$P_{\text{Q(MAX)}} = I_{\text{S(MAX)}} \cdot V^+ (\text{MAX}) \cdot 2 = 82.8\text{mW}$$

$$P_{\text{OUT(MAX)}} = I_{\text{OUT}} \cdot V^+ (\text{MAX}) \cdot 2 = 60\text{mW}$$

$$T_{\text{RISE}} = \theta_{\text{JA}} \cdot P_{\text{TOTAL(MAX)}} = 300^\circ\text{C/W} \cdot (82.8\text{mW} + 60\text{mW}) \approx 43^\circ\text{C}$$

$$T_{\text{MAX}} = T_{\text{AMBIENT}} + T_{\text{RISE}} = 80^\circ\text{C} + 43^\circ\text{C} = 123^\circ\text{C}$$

$$T_{\text{MAX}} \text{ must be } < 150^\circ\text{C}$$

$$P_{\text{TOTAL(MAX)}} \approx 143\text{mW} \text{ and the maximum die temperature will be } 123^\circ\text{C}$$

If this same circuit must run at 125°C , the maximum die temperature will exceed 150°C . (Note that supply current, and therefore P_{Q} , is proportional to temperature. Refer to the Typical Performance Characteristics.) In this condition, the maximum output current should be reduced to avoid device damage. It is important to note that the LTC6103 has been designed to provide at least 1mA to the output when required, and can deliver more depending on the conditions. Care must be taken to limit the maximum output current by proper choice of resistors and, if input fault conditions exist, external clamps.

Output Filtering

The output voltage, V_{OUT} , is simply $I_{\text{OUT}} \cdot Z_{\text{OUT}}$. This makes filtering straightforward. Any circuit may be used which generates the required Z_{OUT} to get the desired filter response. For example, a capacitor in parallel with R_{OUT}

APPLICATIONS INFORMATION

will give a lowpass response. This will reduce unwanted noise from the output, and may also be useful as a charge reservoir to keep the output steady while driving a switching circuit such as a mux or ADC. This output capacitor in parallel with an output resistor will create a pole in the output response at:

$$f_{-3dB} = \frac{1}{2 \cdot \pi \cdot R_{OUT} \cdot C_{OUT}}$$

Useful Equations

Input Voltage: $V_{SENSE} = I_{SENSE} \cdot R_{SENSE}$

Voltage Gain: $\frac{V_{OUT}}{V_{SENSE}} = \frac{R_{OUT}}{R_{IN}}$

Current Gain: $\frac{I_{OUT}}{I_{SENSE}} = \frac{R_{SENSE}}{R_{IN}}$

Transconductance: $\frac{I_{OUT}}{V_{SENSE}} = \frac{1}{R_{IN}}$

Transimpedance: $\frac{V_{OUT}}{I_{SENSE}} = R_{SENSE} \cdot \frac{R_{OUT}}{R_{IN}}$

Reverse Supply Protection

Some applications may be tested with reverse-polarity supplies due to an expectation of this type of fault during operation. The LTC6103 is not protected internally from

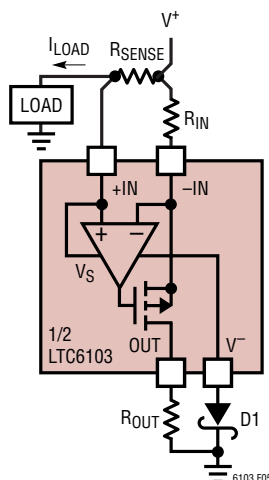

Figure 5. Schottky Prevents Damage During Supply Reversal

external reversal of supply polarity. To prevent damage that may occur during this condition, a Schottky diode should be added in series with V^- (Figure 5). This will limit the reverse current through the LTC6103. Note that this diode will limit the low voltage performance of the LTC6103 by effectively reducing the supply voltage to the part by V_D .

In addition, if the output of the LTC6103 is wired to a device that will effectively short it to high voltage (such as through an ESD protection clamp) during a reverse supply condition, the LTC6103's output should be connected through a resistor or Schottky diode (Figure 6).

Response Time

The LTC6103 is designed to exhibit fast response to inputs for the purpose of circuit protection or signal transmission. This response time will be affected by the external circuit in two ways, delay and speed. If the output current is very low and an input transient occurs, there may be an increased delay before the output voltage begins changing. This can be improved by increasing the minimum output current, either by increasing R_{SENSE} or decreasing R_{IN} . The effect of increased output current is illustrated in the step response curves in the Typical Performance Characteristics of this data sheet. Note that the curves are labeled with respect to the initial output currents.

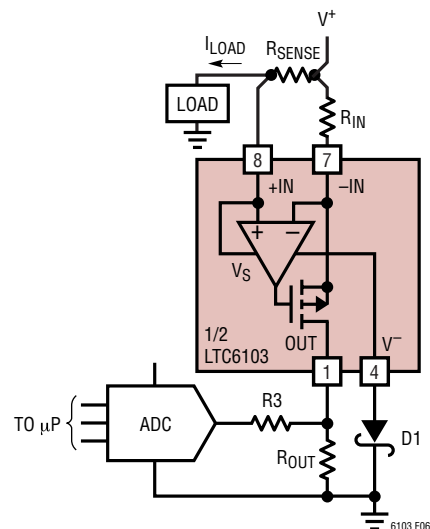

Figure 6. Additional Resistor, R3, Protects Output During Supply Reversal

APPLICATIONS INFORMATION

Voltage Translator

Each amplifier of the LTC6103 can be used as a high voltage level translator circuit as shown in Figure 7. In this application, the LTC6103 translates a differential voltage signal riding on top of a high common mode voltage. V_{IN} signals get converted to a current, through R_{IN} , and then scaled down to a ground referenced voltage across R_{OUT} . Since the V_{SUPPLY} must be at least 4V and the maximum input voltage is 70V, this circuit can translate differential signals with up to 66V of variation in $V_{TRANSLATE}$.

With the dual LTC6103, half of the device can be used to monitor a high side referenced signal and the other amplifier can be used for current sensing.

Output Connection Methods

The outputs of the LTC6103 are current sources and may be connected to subsequent circuitry in several ways. As a dual current sense part, each output can be used independently and in differing ways if desired.

For applications where the destination is local to the device, R_{OUT} resistors may be co-located with the part to form voltage sources. It is also possible to remotely locate

the R_{OUT} resistors so that the current generated output voltage drop is developed against a different ground reference point than the LTC6103 V^- , such as at an ADC within another assembly. This method provides the elimination of ground drop errors from effecting the measurement. Ground differentials that are small enough to prevent conduction of the output protection zener (>8V positive or a couple hundred mV negative) can be rejected without affecting linearity.

In the Typical Application, “ $\pm 10A$ Differential Output Bidirectional Monitor,” the outputs are kept separate, but are treated as a differential pair. This connection allows placing R_{OUT} resistors local to the LTC6103, and yet ground drop errors are rejected at the destination circuit as common mode voltage shift, not signal error. This connection is also shown in the application, $\pm 10A$ Bidirectional H-Bridge Monitor.

The outputs can also be tied together to drive a single R_{OUT} as in the Typical Application, 5A Absolute Value Bidirectional Monitor, producing an additive function. In that particular circuit the two inputs are wired oppositely from the same sense resistor, so the resulting output is an absolute value signal.

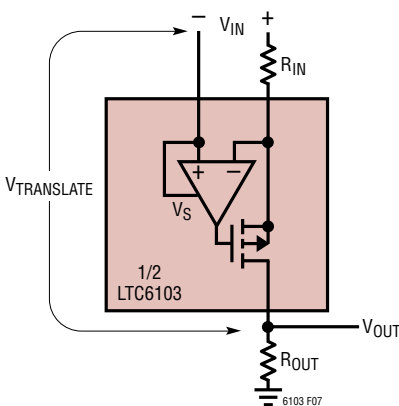
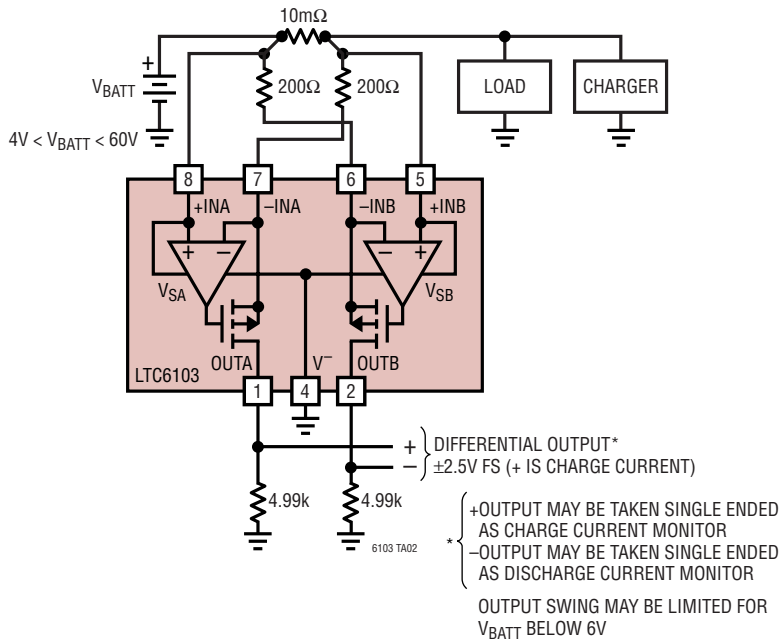

Figure 7. Operation as Voltage Translator

TYPICAL APPLICATIONS

±10A Differential Output Bidirectional Current Monitor



5A Absolute Value Bidirectional Current Monitor

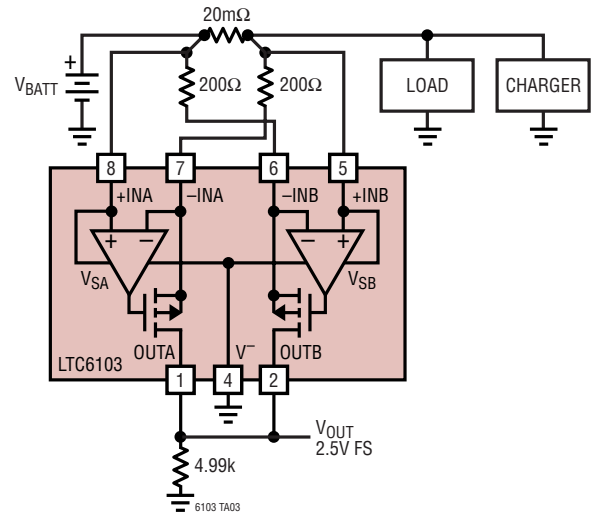

Intelligent High Side Switch with Current Monitor

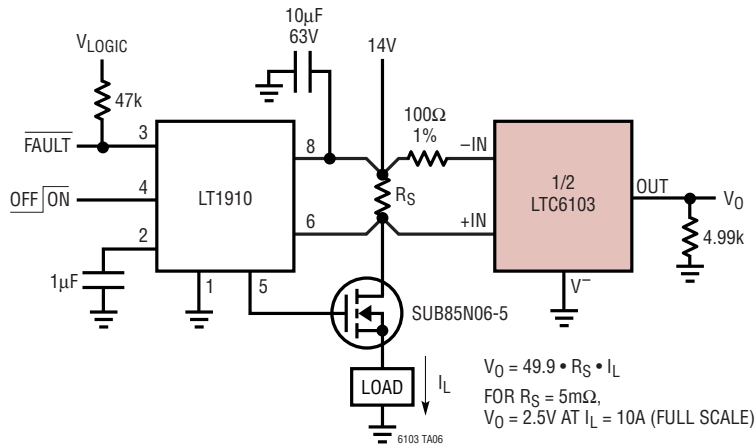

48V Supply Current Monitor with Isolated Output and 70V Survivability

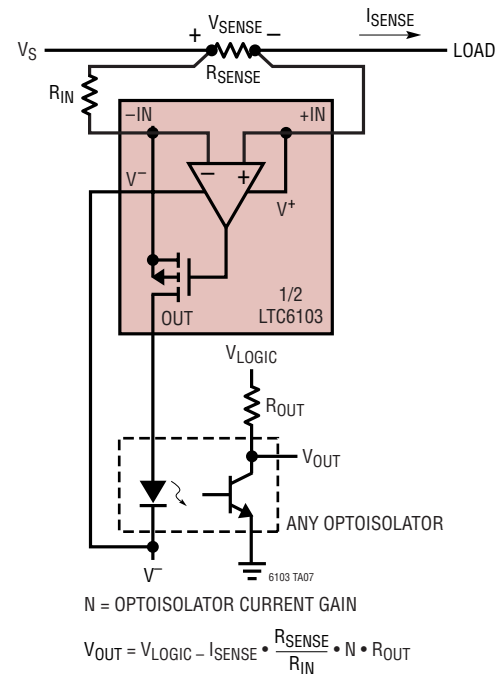

PACKAGE DESCRIPTION

MS8 Package
8-Lead Plastic MSOP
 (Reference LTC DWG # 05-08-1660)

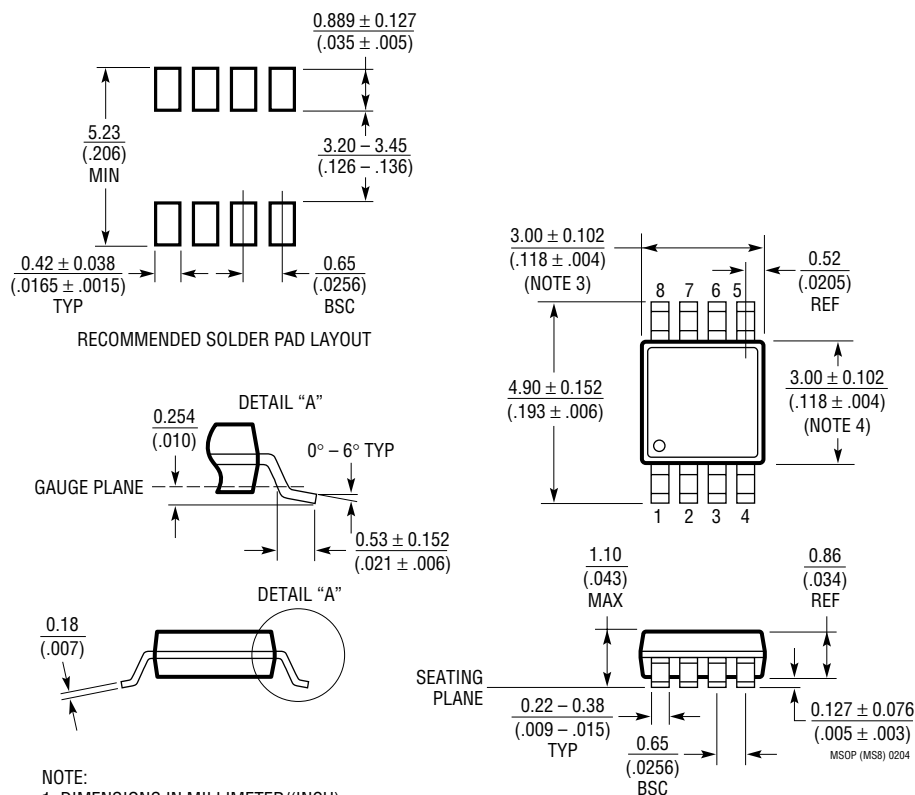

NOTE:

1. DIMENSIONS IN MILLIMETER/(INCH)
2. DRAWING NOT TO SCALE

3. DIMENSION DOES NOT INCLUDE MOLD FLASH, PROTRUSIONS OR GATE BURRS.

MOLD FLASH, PROTRUSIONS OR GATE BURRS SHALL NOT EXCEED 0.152 mm ($.006$) PER SIDE

4. DIMENSION DOES NOT INCLUDE INTERLEAD FLASH OR PROTRUSIONS.

INTERLEAD FLASH OR PROTRUSIONS SHALL NOT EXCEED 0.152 mm ($.006$) PER SIDE

5. LEAD COPLANARITY (BOTTOM OF LEADS AFTER FORMING) SHALL BE 0.102 mm ($.004$) MAX