

High Voltage, High Side, Bi-Directional Current Sense Amplifier

FEATURES

- **Wide Supply Range: 4V to 60V with 70V Absolute Maximum**
- **Low Offset Voltage: $\pm 450\mu\text{V}$ Maximum**
- **Fast Response: 1 μs Response Time**
- **Gain Configurable with External Resistors; Each Direction is Gain Configurable**
- **Low Input Bias Current: 170nA Maximum**
- **PSRR: 110dB Minimum**
- **Output Current: $\pm 1\text{mA}$ Maximum**
- **Low Supply Current: 520 μA , $V_S = 12\text{V}$**
- **Specified for -40°C to 125°C Temperature Range**
- **Available in an 8-Lead MSOP Package**

APPLICATIONS

- Current Shunt Measurement
- Battery Monitoring
- Remote Sensing
- Power Management

LT, LT, LTC and LTM are registered trademarks of Linear Technology Corporation. All other trademarks are the property of their respective owners.

DESCRIPTION

The LTC[®]6104 is a versatile, high voltage, high side, bi-directional current sense amplifier. Design flexibility is provided by the excellent device characteristics: $\pm 450\mu\text{V}$ maximum offset and only 520 μA of current consumption (typical at 12V). The LTC6104 operates on supplies from 4V to 60V.

The LTC6104 monitors bi-directional current via the voltage across an external sense resistor (shunt resistor). This sense voltage is then translated into a ground referenced signal. Gain is set with three external resistors and can be separately configured for both directions. Low DC offset allows the use of a small shunt resistor and large gain-setting resistors. As a result, power loss in the shunt is minimal.

The wide operating supply range and high accuracy make the LTC6104 ideal for a wide variety of automotive, industrial and power management applications. A maximum input sense voltage of 500mV allows a wide range of currents to be monitored. The fast response makes the LTC6104 the perfect choice for load current warnings and shutoff protection control. With very low supply current, the LTC6104 is suitable for power sensitive applications.

The LTC6104 is available in an 8-lead MSOP package.

TYPICAL APPLICATION

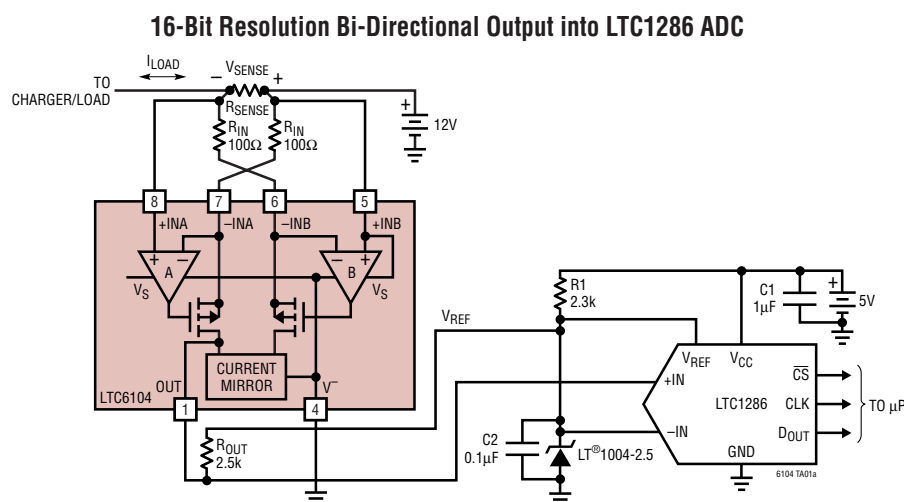

Step Response

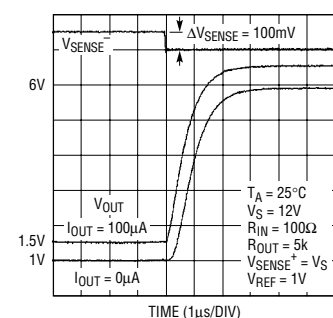

6104 G15

ABSOLUTE MAXIMUM RATINGS

(Note 1)

Total Supply Voltage (+INB(V _S) to V ⁻)	70V
Maximum Applied Output Voltage (OUT)	9V
Input Current.....	±10mA
Output Short-Circuit Duration (to V ⁻).....	Indefinite
Operating Temperature Range	
LTC6104C	-40°C to 85°C
LTC6104I	-40°C to 85°C
LTC6104H	-40°C to 125°C
Specified Temperature Range (Note 2)	
LTC6104C	0°C to 70°C
LTC6104I	-40°C to 85°C
LTC6104H	-40°C to 125°C
Storage Temperature Range.....	-65°C to 150°C
Lead Temperature (Soldering, 10 sec)	300°C

PACKAGE/ORDER INFORMATION

ORDER PART NUMBER	MS8 PART MARKING*
LTC6104CMS8	LTCMP
LTC6104IMS8	LTCMP
LTC6104HMS8	LTCMP
Order Options Tape and Reel: Add #TR Lead Free: Add #PBF Lead Free Tape and Reel: Add #TRPBF Lead Free Part Marking: http://www.linear.com/leadfree/	

Consult LTC Marketing for parts specified with wider operating temperature ranges.
 *The temperature grade is identified by a label on the shipping container.

ELECTRICAL CHARACTERISTICS

The ● denotes the specifications which apply over the full operating temperature range, otherwise specifications are at T_A = 25°C. R_{IN} = 100Ω, R_{OUT} = 5k, 4V ≤ +INB(V_S) ≤ 60V, V⁻ = 0V, V_{REF} = 2V for V_S ≥ 6V, V_{REF} = 0.75V for V_S = 4V, unless otherwise noted.

SYMBOL	PARAMETER	CONDITIONS	MIN	TYP	MAX	UNITS
V _S	Supply Range	●	4		60	V
V _{OS}	Output Offset Voltage	V _{SENSE} = ±5mV, LTC6104 ● V _{SENSE} = ±5mV, LTC6104C, LTC6104I ● V _{SENSE} = ±5mV, LTC6104H ●		±85	±450 ±600 ±700	μV μV μV
ΔV _{OS} /ΔT	Input Offset Voltage Drift	V _{SENSE} = ±5mV ●		±1.5		μV/°C
I _B	Input Bias Current	R _{IN} = 1M for -INA and -INB ●		100	170 245	nA nA
V _{SENSE(MAX)} (Note 3)	Input Sense Voltage Full Scale	6V ≤ V _S ≤ 60V, R _{IN} = 1k, R _{OUT} = 2k, V _{REF} = 2V ● V _S = 4V, R _{IN} = 1k, R _{OUT} = 1k, V _{REF} = 0.5V when V _{SENSE} = 500mV, V _{REF} = 1V when V _{SENSE} = -500mV ●	±500 ●			mV mV
PSRR	Power Supply Rejection Ratio	V _S = 6V to 60V, V _{SENSE} = 5mV ● V _S = 6V to 60V, V _{SENSE} = -5mV ● V _S = 4V to 60V, V _{SENSE} = 5mV ● V _S = 4V to 60V, V _{SENSE} = -5mV ●	116 ● 112 ●	140		dB dB dB dB
V _{OUT(MAX)}	Maximum Output Voltage	12V ≤ V _S ≤ 60V, V _{SENSE} = 90mV, V _{REF} = 4V ● V _S = 6V, V _{SENSE} = 75mV, V _{REF} = 1.8V, R _{OUT} = 2k ● V _S = 4V, V _{SENSE} = 35mV, V _{REF} = 0.75V, R _{OUT} = 1k ●	8 ● 3 ● 1 ●			V V V
V _{OUT(MIN)}	Minimum Output Voltage	12V ≤ V _S ≤ 60V, V _{SENSE} = -80mV, V _{REF} = 4V ● V _S = 6V, V _{SENSE} = -90mV, V _{REF} = 1.8V, R _{OUT} = 2k ● V _S = 4V, V _{SENSE} = -75mV, V _{REF} = 0.75V, R _{OUT} = 1k ●			0.3 ● 0.3 ● 0.25 ●	V V V

ELECTRICAL CHARACTERISTICS

The ● denotes the specifications which apply over the full operating temperature range, otherwise specifications are at $T_A = 25^\circ\text{C}$. $R_{IN} = 100\Omega$, $R_{OUT} = 5k$, $4V \leq +INB(V_S) \leq 60V$, $V^- = 0V$, $V_{REF} = 2V$ for $V_S \geq 6V$, $V_{REF} = 0.75V$ for $V_S = 4V$, unless otherwise noted.

SYMBOL	PARAMETER	CONDITIONS	MIN	TYP	MAX	UNITS	
$I_{OUT(MAX)}$	Maximum Output Current	$6V \leq V_S \leq 60V$, $V_{SENSE} = \pm 110mV$, $V_{REF} = 2V$, $R_{OUT} = 1k$ $V_S = 4V$, $V_{SENSE} = \pm 27.5mV$, $V_{REF} = 0.75V$, $R_{OUT} = 1k$	● ●	± 1 ± 0.25		mA mA	
$I_{OUT-GAINERR}$	Current Mirror Gain Error	$V_{INB^-} > V_{INB^+}$ and $V_{INA^-} < V_{INA^+}$ (Note 4)		± 0.2	± 0.75	%	
$I_{OUT-OSERR}$	Current Mirror Offset Error	$V_{INB^-} > V_{INB^+}$ and $V_{INA^-} < V_{INA^+}$ (Note 4)		± 0.2		μA	
t_r	Input Step Response ($\Delta V_{OUT} =$ to 50% on a 5V Output Step)	$8V \leq V_S \leq 60V$, $V_{REF} = 1V$, $V_{SENSE} = 0mV$ to 100mV Transient		1		μs	
		$8V \leq V_S \leq 60V$, $V_{REF} = 6V$, $V_{SENSE} = -100mV$ to 0mV Transient		1		μs	
		$8V \leq V_S \leq 60V$, $V_{REF} = 4V$, $V_{SENSE} = -50mV$ to 50mV Transient		3		μs	
	Input Step Response ($\Delta V_{OUT} =$ to 50% on a 0.5V Output Step)	$V_S = 4V$, $R_{OUT} = 500\Omega$, Gain = 5, $V_{REF} = 0.5V$, $V_{SENSE} = 0mV$ to 100mV Transient			1.2		μs
		$V_S = 4V$, $R_{OUT} = 500\Omega$, Gain = 5, $V_{REF} = 1V$, $V_{SENSE} = -100mV$ to 0mV Transient			1.2		μs
		$V_S = 4V$, $R_{OUT} = 500\Omega$, Gain = 5, $V_{REF} = 0.75V$, $V_{SENSE} = -50mV$ to 50mV Transient			3.2		μs
BW	Signal Bandwidth	$I_{OUT} = 200\mu A$, $R_{OUT} = 5k$		140		kHz	
		$I_{OUT} = -200\mu A$, $R_{OUT} = 5k$		140		kHz	
		$I_{OUT} = 1mA$, $R_{OUT} = 5k$		200		kHz	
		$I_{OUT} = -1mA$, $R_{OUT} = 5k$		200		kHz	
I_S	Supply Current	$V_S = 4V$, $I_{OUT} = 0$, $R_{IN} = 1M$	●	0.45	0.73 0.825	mA mA	
		$V_S = 6V$, $I_{OUT} = 0$, $R_{IN} = 1M$	●	0.5	0.79 1	mA mA	
		$V_S = 12V$, $I_{OUT} = 0$, $R_{IN} = 1M$	●	0.52	0.81 1	mA mA	
		$V_S = 60V$, $I_{OUT} = 0$, $R_{IN} = 1M$ LTC6104I, LTC6104C LTC6104H	● ● ●	0.64	1.04 1.1 1.2	mA mA mA	

Note 1: Stresses beyond those listed under Absolute Maximum Ratings may cause permanent damage to the device. Exposure to any Absolute Maximum Rating condition for extended periods may affect device reliability and lifetime.

Note 2: The LTC6104C is guaranteed to meet specified performance from 0°C to 70°C . The LTC6104C is designed, characterized and expected to meet specified performance from -40°C to 85°C but are not tested or QA sampled at these temperatures. LTC6104I is guaranteed to meet specified performance from -40°C to 85°C . The LTC6104H is guaranteed to meet specified performance from -40°C to 125°C .

Note 3: $V_{SENSE(MAX)}$ is tested by applying 550mV and verifying the gain error is less than 1%. The 1% limit is set by the accuracy of high speed test equipment. Gain error is typically dominated by external resistor tolerance.

Note 4: When amplifier A is active and amplifier B is inactive, the gain error is entirely due to the external resistors R_{IN} and R_{OUT} . When amplifier A is inactive and amplifier B is active, there is an additional gain error from the LTC6104 current mirror circuit. This error term is the gain error term, $I_{OUT-GAINERR}$ plus the offset error term, $I_{OUT-OSERR}$.

TYPICAL PERFORMANCE CHARACTERISTICS

Input V_{OS} vs Temperature

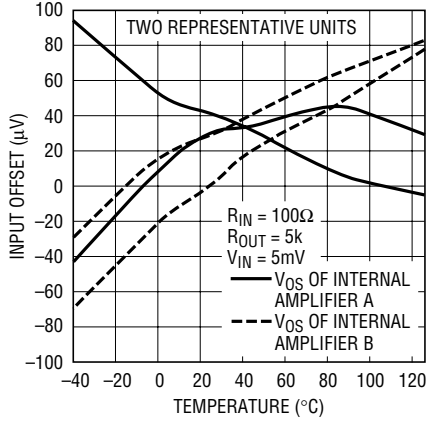

6104 G01

Input V_{OS} vs Supply Voltage

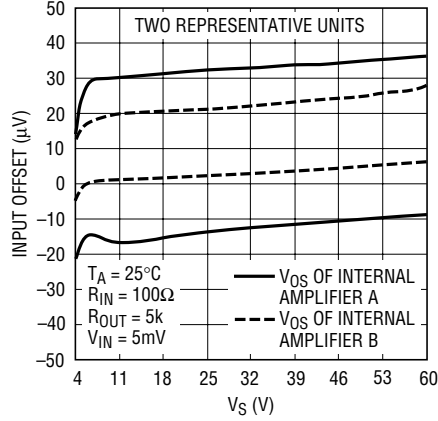

6104 G02

Input Sense Range vs Supply Voltage

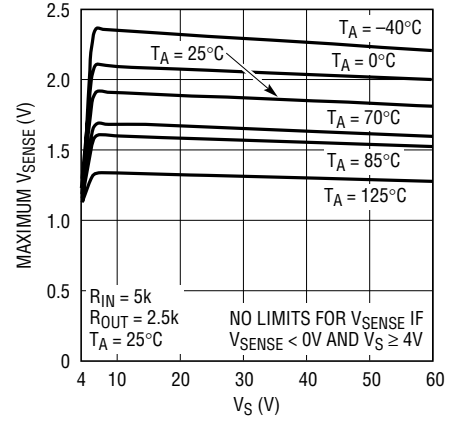

6104 G03

V_{OUT} Maximum vs Temperature

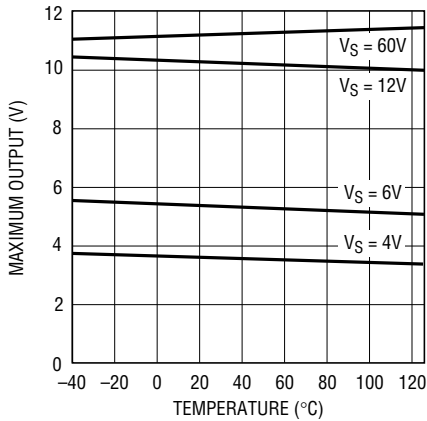

6104 G04

V_{OUT} Minimum vs Temperature

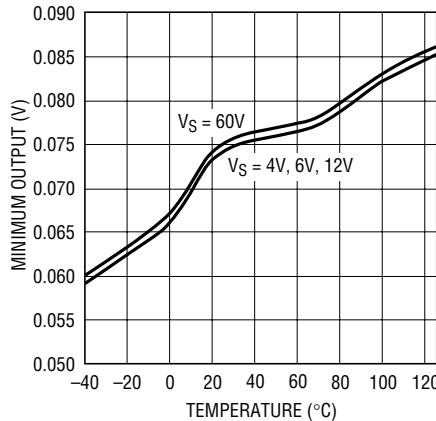

6104 G05

I_{OUT} Maximum vs Temperature

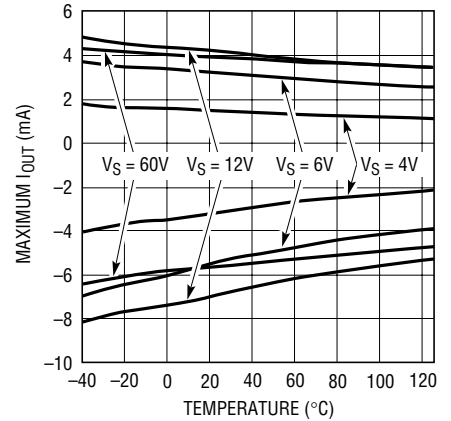

6104 G06

Gain vs Frequency

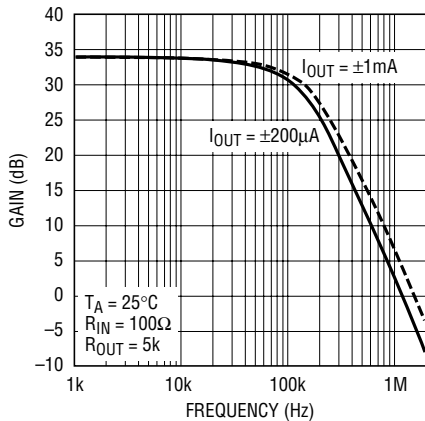

6104 G08

Input Bias Current vs Temperature

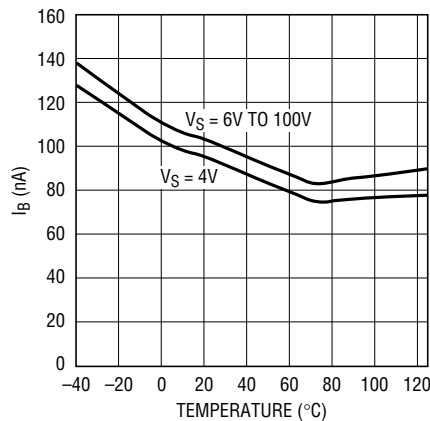

6104 G09

Supply Current vs Supply Voltage

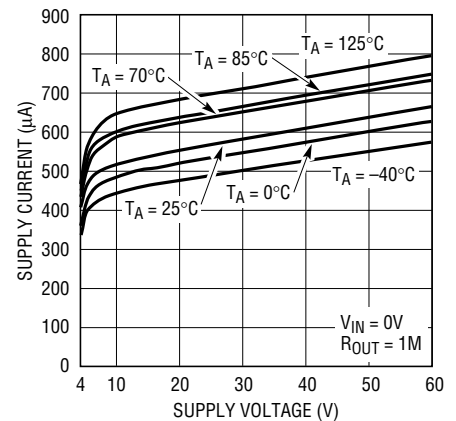

6104 G10

TYPICAL PERFORMANCE CHARACTERISTICS

Step Response 0mV to 10mV

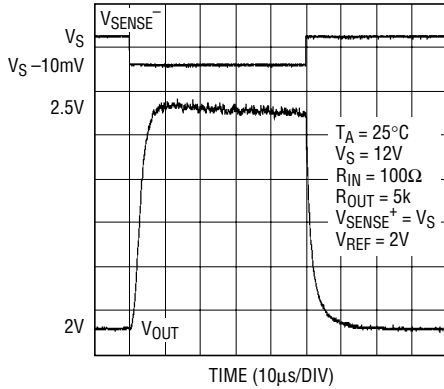

6104 G11

Step Response 0mV to -10mV

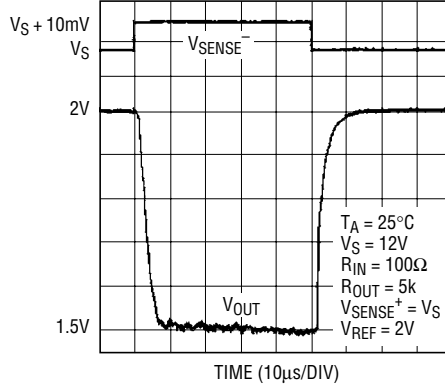

6104 G12

Step Response -5mV to 5mV

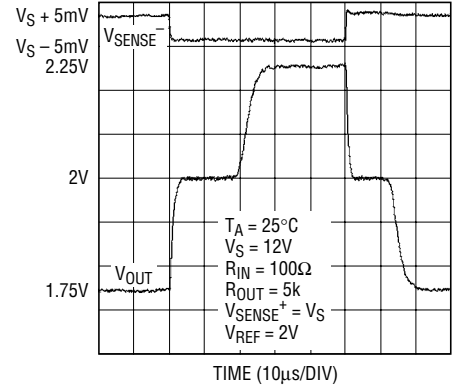

6104 G13

Step Response -50mV to 50mV

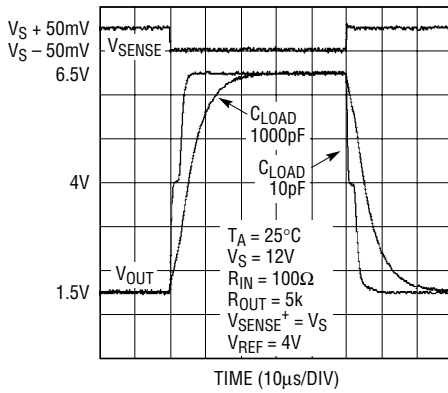

6104 G14

Step Response Rising Edge

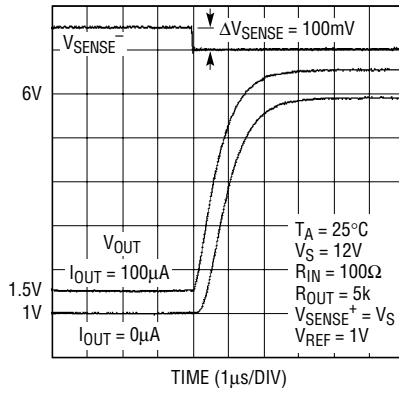

6104 G15

Step Response Rising Edge

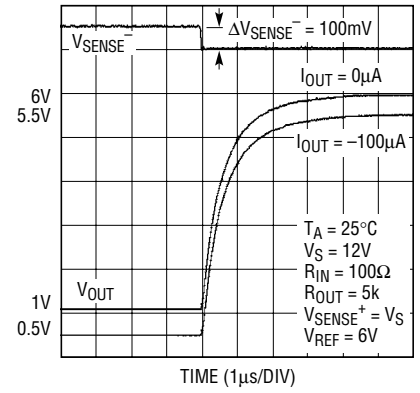

6104 G16

Step Response Rising Edge

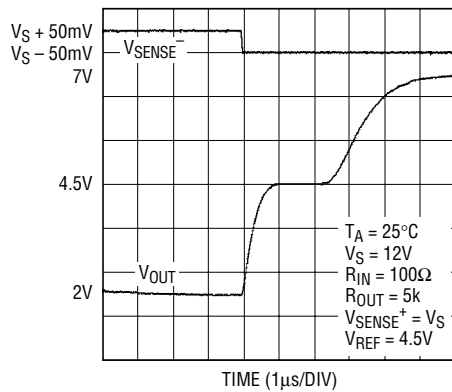

6104 G17

Step Response Falling Edge

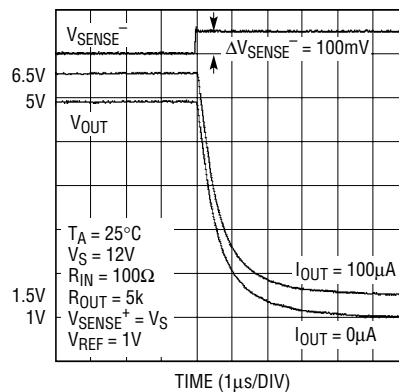

6104 G18

TYPICAL PERFORMANCE CHARACTERISTICS

Step Response Falling Edge

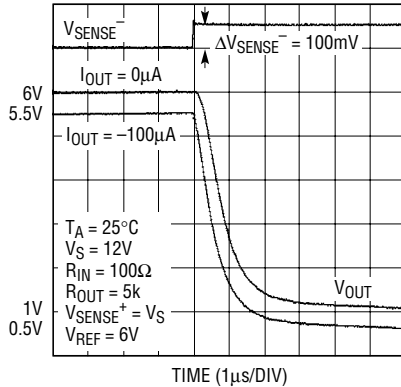

6104 G19

Step Response Falling Edge

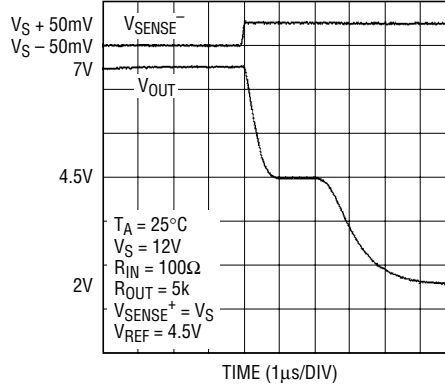

6104 G20

PSRR vs Frequency

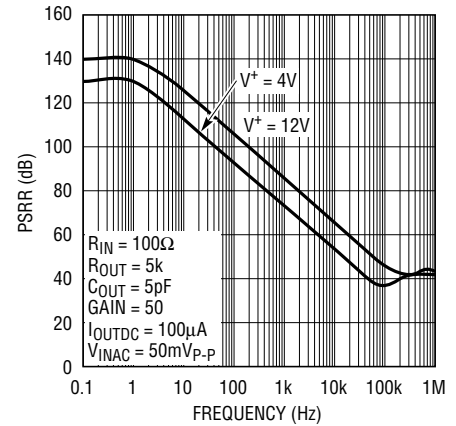

6104 G20

PIN FUNCTIONS

OUT (Pin 1): Current Output. OUT will source or sink a current that is proportional to the sense voltage into an external resistor. A voltage reference is required to provide the proper positive offset voltage so that the output can swing both positive and negative.

V⁻ (Pin 4): Negative Supply (or Ground for Single-Supply Operation).

+INB/V_S (Pin 5): The positive input of the internal sense amplifier B. It also works as the positive supply input. Supply current is drawn through this pin.

-INB (Pin 6): The negative input of the internal sense amplifier B. The internal sense amplifier will drive -INB to the same potential as +INB when V_{SENSE} is negative.

A resistor (R_{IN}) tied from one end of R_{SENSE} to -INB sets the output current $I_{OUT} = V_{SENSE}/R_{IN}$. V_{SENSE} is the voltage developed across the external R_{SENSE} (Figure 1).

-INA (Pin 7): The negative input of the internal sense amplifier A. The internal sense amplifier will drive -INA to the same potential as +INA when V_{SENSE} is positive. A resistor (R_{IN}) tied from one end of R_{SENSE} to -INA sets the output current $I_{OUT} = V_{SENSE}/R_{IN}$.

+INA (Pin 8): The positive input of the internal sense amplifier A.

BLOCK DIAGRAM

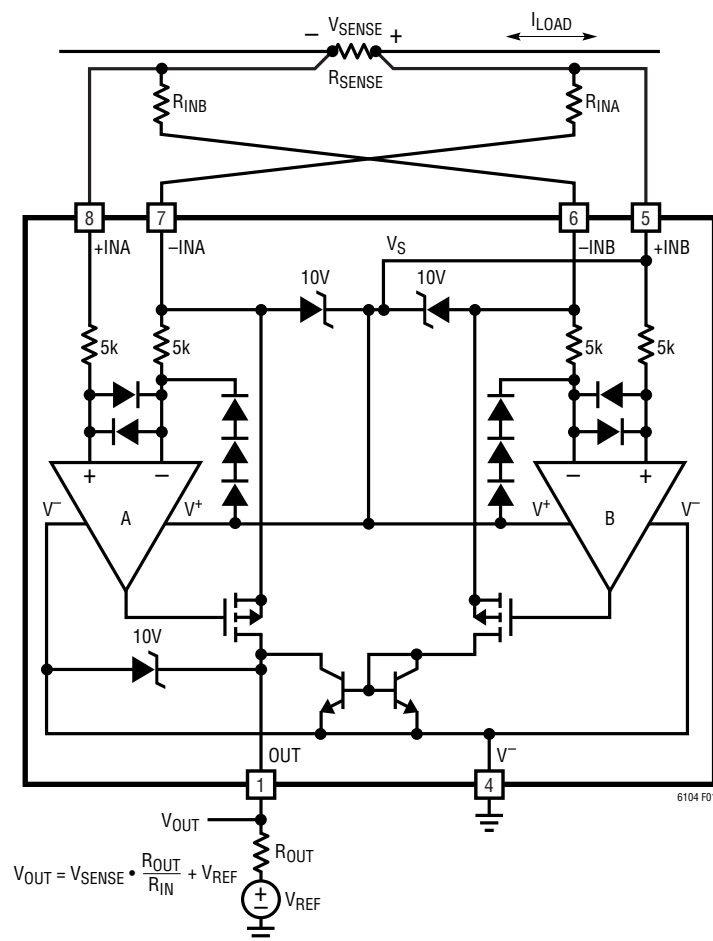

Figure 1. LTC6104 Block Diagram

THEORY OF OPERATION

When V_{SENSE} is positive, an internal sense amplifier loop forces $-INA$ to have the same potential as $+INA$. Connecting an external resistor, R_{INA} , in series with $-INA$ causes a current, V_{SENSE}/R_{INA} , to flow through R_{INA} . The high impedance inputs of the sense amplifier will not conduct this input current, so the current will flow through an internal MOSFET to the OUT pin.

The output current can be transformed into a voltage by adding a resistor from OUT to a reference voltage (V_{REF}). The output voltage is then $V_{OUT} = (V_{SENSE}/R_{INA}) \cdot R_{OUT} + V_{REF}$. When operating on a dual supply, R_{OUT} can be tied to ground. The output voltage is then $V_{OUT} = (V_{SENSE}/R_{INA}) \cdot R_{OUT}$.

Only one amplifier is active at a time in the LTC6104. If the load current direction (V_{SENSE} is negative) activates the

“B” amplifier, the “A” amplifier will be inactive. The signal current goes into the $-INB$ pin, through the MOSFET, and into the current mirror. The mirror reverses the polarity of the signal so that current flows into the “OUT” pin, causing the output voltage to change polarity. The magnitude of the output is then $V_{SENSE} \cdot R_{OUT}/R_{INB} + V_{REF}$. Keep in mind that the OUT voltage cannot swing below V^- , even though it’s sinking current. A proper V_{REF} and R_{OUT} need to be chosen so that the designed OUT voltage swing does not go beyond the specified voltage range of the output.

Supply current is drawn from $+INB$ pin. The user may choose to include this current in the monitored current through R_{SENSE} by careful choice of connection polarity.

APPLICATIONS INFORMATION

Selection of External Current Sense Resistor

The external sense resistor, R_{SENSE} , has a significant effect on the function of a current sensing system and must be chosen with care.

First, the power dissipation in the resistor should be considered. The system load current will cause both heat and voltage loss in R_{SENSE} . As a result, the sense resistor should be as small as possible while still providing the input dynamic range required by the measurement. Note that input dynamic range is the difference between the maximum input signal and the minimum accurately reproduced signal, and is limited primarily by input DC offset of the internal amplifier of the LTC6104. In addition, R_{SENSE} must be small enough that V_{SENSE} does not exceed the maximum input voltage specified by the LTC6104, even under peak load conditions.

As an example, an application may require that the maximum sense voltage be $\pm 100\text{mV}$. If this application is expected to draw $\pm 2\text{A}$ at peak load, R_{SENSE} should be no more than $50\text{m}\Omega$.

$$R_{SENSE} = \frac{V_{SENSE}}{I_{PEAK}} = \frac{100\text{mV}}{2\text{A}} = 50\text{m}\Omega$$

Once the maximum R_{SENSE} value is determined, the minimum sense resistor value will be set by the resolution or dynamic range required. The minimum signal that can be accurately represented by this sense amp is limited by the input offset. As an example, the LTC6104 has a typical input offset of $\pm 85\mu\text{V}$. If the minimum current is $\pm 20\text{mA}$, a sense resistor of $4.25\text{m}\Omega$ will set V_{SENSE} to $\pm 85\mu\text{V}$. This is the same value as the input offset. A larger sense resistor will reduce the error due to offset by increasing the sense voltage for a given load current.

Choosing a $50\text{m}\Omega$ R_{SENSE} will maximize the dynamic range and provide a system that has $\pm 100\text{mV}$ across the sense resistor at peak load ($\pm 2\text{A}$), while input offset causes an error equivalent to only $\pm 1.7\text{mA}$ of load current. Peak dissipation in the sense resistor is 200mW in this example.

If instead a $5\text{m}\Omega$ sense resistor is employed, then the effective current error is $\pm 17\text{mA}$, while the peak sense voltage is reduced to $\pm 10\text{mV}$ at $\pm 2\text{A}$, dissipating only 20mW .

The low offset and corresponding large dynamic range of the LTC6104 make it more flexible than other solutions in this respect. The $\pm 85\mu\text{V}$ typical offset gives 60dB of dynamic range for a sense voltage that is limited to $\pm 85\text{mV}$ max, and over 75dB of dynamic range if the rated input maximum of $\pm 500\text{mV}$ is allowed.

Sense Resistor Connection

Kelvin connection of the $-INA/-INB$ and $+INA/+INB$ inputs to the sense resistor should be used in all but the lowest power applications. Solder connections and PC board interconnections that carry high current can cause significant error in measurement due to their relatively large resistances. One $10\text{mm} \times 10\text{mm}$ square trace of one-ounce copper is approximately $0.5\text{m}\Omega$. A 1mV error can be caused by as little as 2A flowing through this small interconnect. This will cause a 1% error in a 100mV signal. A 10A load current in the same interconnect will cause a 5% error for the same 100mV signal. By isolating the sense traces from the high current paths, this error can be reduced by orders of magnitude. A sense resistor with integrated Kelvin sense terminals will give the best results. Figure 2 illustrates the recommended method.

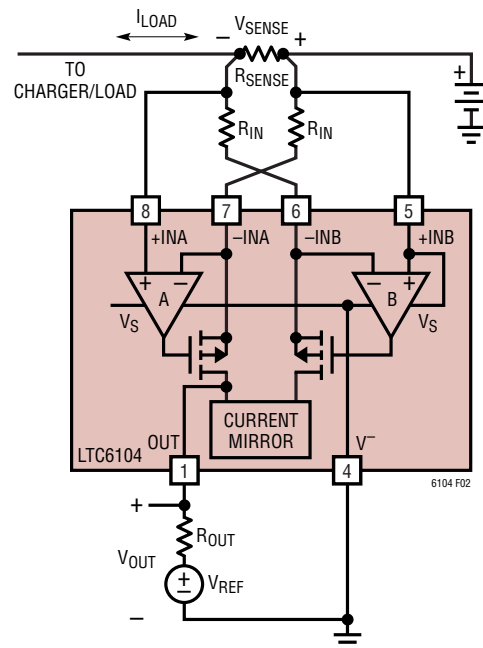

Figure 2. Kelvin Input Connections Preserve Accuracy Despite Large Load Currents

APPLICATIONS INFORMATION

Selection of External Input Resistor, R_{IN}

The external input resistor, R_{IN} , controls the transconductance of the current sense circuit.

$$\text{Since } I_{OUT} = \frac{V_{SENSE}}{R_{IN}}, \text{ transconductance } g_m = \frac{1}{R_{IN}}$$

$$\text{For example, if } R_{IN} = 100\Omega, \text{ then } I_{OUT} = \frac{V_{SENSE}}{100\Omega} \text{ or}$$

$$I_{OUT} = \pm 1\text{mA for } V_{SENSE} = \pm 100\text{mV.}$$

R_{IN} should be chosen to allow the required resolution while limiting the output current. At low supply voltage, I_{OUT} may be as much as $\pm 1\text{mA}$. By setting R_{IN} such that the largest expected sense voltage gives $I_{OUT} = \pm 1\text{mA}$, then the maximum output dynamic range is available. Output dynamic range is limited by both the maximum allowed output current and the maximum allowed output voltage, as well as the minimum practical output signal. If less dynamic range is required, then R_{IN} can be increased accordingly, reducing the maximum output current and power dissipation. If low sense currents must be resolved accurately in a system that has very wide dynamic range, a smaller R_{IN} than the maximum current specification allows may be used if the maximum current is limited in another way, such as with a Schottky diode across R_{SENSE} (Figure 3). This will reduce the high current measurement accuracy by limiting the result, while increasing the low current measurement resolution. This approach can be helpful in cases where occasional large burst currents may be ignored.

Care should be taken when designing the printed circuit board layout to minimize input trace resistance (to Pins 5, 6, 7 and 8). Trace and interconnect impedances to the

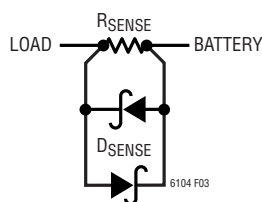

Figure 3. Shunt Diodes Limit Maximum Input Voltage to Allow Better Low Input Resolution Without Overranging

$-IN$ terminals will increase the effective R_{IN} value, causing a gain error, especially for small R_{IN} values. In addition, internal device resistance will add approximately 0.3Ω to R_{IN} .

Trace and interconnect impedances to the $+INB$ terminal will have an effect on offset error. These errors are described in more detail later in this data sheet.

Selection of External Output Resistor, R_{OUT}

The output resistor, R_{OUT} , determines how the output current is converted to voltage. V_{OUT} is simply $I_{OUT} \cdot R_{OUT} + V_{REF}$. In choosing an output resistor, the maximum output voltage range must first be considered. If the circuit that is driven by the output does not limit the output voltage range, then R_{OUT} must be chosen such that the maximum output voltage range does not exceed the LTC6104 maximum output voltage range (see Electrical Characteristics). If the following circuit is a buffer or ADC with limited input range, then R_{OUT} must be chosen so that V_{OUT} is in the allowed maximum input range of this circuit.

In addition, the output impedance is determined by R_{OUT} . If the circuit to be driven has high enough input impedance, then almost any useful output impedance will be acceptable. However, if the driven circuit has relatively low input impedance, or draws spikes of current, such as an ADC might do, then a lower R_{OUT} value may be required in order to preserve the accuracy of the output. As an example, if the input impedance of the driven circuit is 100 times R_{OUT} , then the accuracy of V_{OUT} will be reduced by 1% since:

$$\begin{aligned} V_{OUT} - V_{REF} &= I_{OUT} \cdot \frac{R_{OUT} \cdot R_{IN(DRIVEN)}}{R_{OUT} + R_{IN(DRIVEN)}} \\ &= I_{OUT} \cdot R_{OUT} \cdot \frac{100}{101} = 0.99 \cdot I_{OUT} \cdot R_{OUT} \end{aligned}$$

Selection of External Voltage Reference, V_{REF}

Selection of external reference voltage should be considered together with selection of R_{OUT} .

Example:

Given the conditions: $I_{OUT} = -1\text{mA to } 1\text{mA}$, $V_S = 12\text{V}$.

APPLICATIONS INFORMATION

From the Electrical Characteristics of the LTC6104, the output voltage range is 0.3V to 8V.

If the circuit that is driven by the output limits the maximum output voltage to $\approx 5V$, to achieve maximum dynamic range, V_{OUT} should be 0.3V for $-1mA$ I_{OUT} and 5V for $1mA$ I_{OUT} .

$$R_{OUT} = \frac{5V - 0.3V}{2mA} = 2.35k,$$

$$V_{REF} = 0.3 + \frac{5 - 0.3}{2} = 2.65V$$

A standard 2.5V reference could be used in this example. With $I_{OUT} = \pm 1mA$ and $R_{OUT} = 2.2k$, the output voltage range would equal 0.3V to 4.7V

V_{REF} Considerations

V_{REF} as shown in Figure 1, provides a positive offset so that the output can swing above and below this point. It is recommended that this is an accurate voltage reference. Most voltage references will work in this application as long as they are able to sink and source current. Make sure that the device maintains the required voltage accuracy as the current varies through its entire range.

Error Sources

The current sense system uses an amplifier and resistors to apply gain and level shift the result. The output is then dependent on the characteristics of the amplifier, such as gain and input offset, as well as resistor matching. Ideally, the circuit output is:

$$V_{OUT} - V_{REF} = I_{OUT} \cdot R_{OUT} = V_{SENSE} \cdot \frac{R_{OUT}}{R_{IN}},$$

$$V_{SENSE} = R_{SENSE} \cdot I_{SENSE}$$

In this case, the only error is due to resistor mismatch, which provides an error in gain only. However, offset voltage, bias current and finite gain in the amplifier cause additional errors.

Output Error, E_{OUT} , Due to the Amplifier DC Offset Voltage, V_{OS}

$$E_{OUT(VOS)} = V_{OS} \cdot \frac{R_{OUT}}{R_{IN}}$$

The DC offset voltage of the amplifier adds directly to the value of the sense voltage, V_{SENSE} . This is the dominant error of the system and it limits the available dynamic range. The section, Selection of External Current Sense Resistor, provides details.

Output Error, E_{OUT} , Due to the Bias Currents, I_B^+ and I_B^-

The bias current I_B^+ flows into the positive input of the internal op amp. I_B^- flows into the negative input.

$$E_{OUT(IBIAS)} = R_{OUT} \left(I_B^+ \cdot \frac{R_{SENSE}}{R_{IN}} - I_B^- \right)$$

Since $I_B^+ \approx I_B^- = I_{BIAS}$, if $R_{SENSE} \ll R_{IN}$ then:

$$E_{OUT(IBIAS)} \approx -R_{OUT} \cdot I_{BIAS}$$

For instance if I_{BIAS} is 100nA and R_{OUT} is 1k, the output error is 0.1mV.

Output Error, E_{OUT} , Due to the Finite DC Open-Loop Gain, A_{OL} , of the LTC6104 Amplifier

This error is inconsequential as the A_{OL} of the LTC6104 is very large.

Example:

If an I_{SENSE} range = ($\pm 1mA$ to $\pm 1A$) and $\frac{V_{OUT}}{I_{SENSE}} = \frac{3V}{1A}$

Then, from the Electrical Characteristics of the LTC6104:

$$R_{SENSE} \approx \frac{V_{SENSE(MAX)}}{I_{SENSE(MAX)}} = \frac{500mV}{1A} = 500m\Omega$$

$$\text{Gain} = \frac{R_{OUT}}{R_{IN}} = \frac{V_{OUT(MAX)}}{V_{SENSE(MAX)}} = \frac{3V}{500mV} = 6$$

APPLICATIONS INFORMATION

If the maximum output current, I_{OUT} , is limited to 1mA, R_{OUT} equals $3V/1mA = 3k$ and $R_{IN} = 3k/6 - 0.3\Omega$ (internal device resistance) = 499.7Ω .

The output error due to DC offset is $\pm 510\mu V$ (typ) and the error due to offset current, I_{OS} , is $3k \cdot 100nA = 300\mu V$ (typ).

The maximum output error can therefore reach $\pm 810\mu V$ or 0.027% (-71dB) of the output full scale. Considering the system input 60dB dynamic range ($I_{SENSE} = \pm 1mA$ to $\pm 1A$), the 71dB performance of the LTC6104 makes this application feasible.

Output Error, E_{OUT} , Due to the Current Mirror Errors, $I_{OUT-GAINERR}$ and $I_{OUT-OSERR}$

When V_{SENSE} is negative, amplifier B would be on and amplifier A off. The output of amplifier B drives an internal current mirror which is connected to the OUT pin. This current mirror has some error associated with it, and this error can be calculated as follows:

$$I_{OUT-GAINERR} = \pm 0.2\% \cdot I_{OUT}, \text{ with } I_{OUT} = \pm 1mA, \\ I_{OUT-GAINERR(MAX)} = \pm 2\mu A$$

$$I_{OUT-OSERR} = \pm 0.2\mu A$$

$$I_{OUT-ERR(MAX)} = I_{OUT-GAINERR} + I_{OUT-OSERR} = \pm 2\mu A + \pm 0.2\mu A = \pm 2.2\mu A$$

$$E_{OUT-ERR(MAX)} = I_{OUT-ERR(MAX)} \cdot R_{OUT}$$

The combined effect of amplifier offset and current mirror errors is shown graphically in Figure 4.

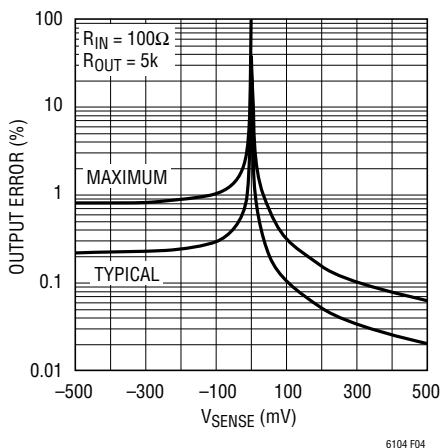

Figure 4. Output Error vs Input Voltage

Output Error, E_{OUT} , Due to Trace Resistance

The LTC6104 uses the +INB pin for both the positive “B” amplifier input and the positive supply input for both amplifiers. If trace resistance (R_T) become significant (Figure 5), this supply current can cause an input offset error, which can be calculated as follows:

$$E_{OUT(OFFSET)} = R_T \cdot I_S \cdot \frac{R_{OUT}}{R_{IN}}$$

Trace resistances to the -IN terminals will increase the effective R_{IN} value, causing a gain error (Figure 5). In addition, internal device resistance will add approximately 0.3Ω to R_{IN} .

Gain error equals:

$$A_{V(ERROR)} = \frac{R_{OUT}}{R_{IN} + R_T + 0.3\Omega} - \frac{R_{OUT}}{R_{IN}}$$

Minimizing resistance in the input traces is important and care should be taken in the PCB layout. Make the trace short and wide. Kelvin connection to the shunt resistor pad should be used. Avoid tapping into this signal along

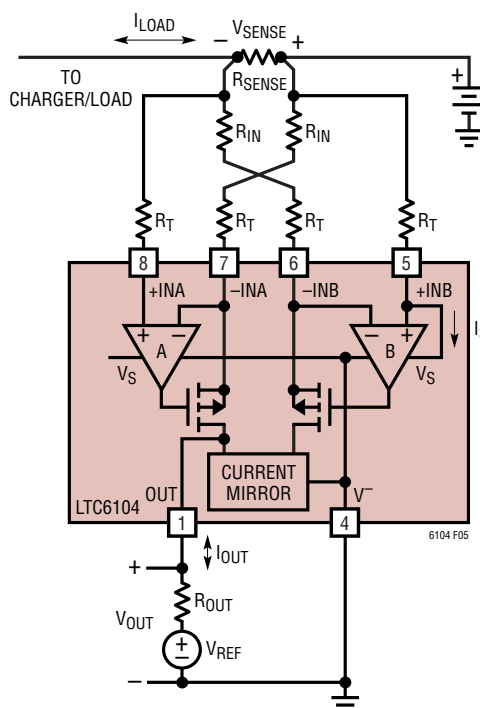

Figure 5. Errors from PCB Traces and Other Parasitic Resistances

APPLICATIONS INFORMATION

the high current path, as this will increase the voltage drop and escalate this error.

Output Current Limitations Due to Power Dissipation

The LTC6104 can deliver up to $\pm 1\text{mA}$ continuous current to the output pin. This current flows through R_{IN} and enters the current sense amp via the $-IN$ pin. The power dissipated in the LTC6104 due to the output signal is:

$$P_{OUT} \approx V_S \cdot |I_{OUT}|$$

There is also power dissipated due to the quiescent supply current:

$$P_Q = I_S \cdot V_S$$

The total power dissipated is the output dissipation plus the quiescent dissipation:

$$P_{TOTAL} = P_{OUT} + P_Q$$

At maximum supply and maximum output current, the total power dissipation can exceed 100mW. This will cause significant heating of the LTC6104 die. In order to prevent damage to the LTC6104, the maximum expected dissipation in each application should be calculated. This number can be multiplied by the θ_{JA} value to find the maximum expected die temperature. This must not be allowed to exceed 150°C , or performance may be degraded.

As an example, if an LTC6104 in the MS8 package is to be run at $55\text{V} \pm 5\text{V}$ supply with 1mA output current at 80°C :

$$P_{Q(MAX)} = I_{S(MAX)} \cdot V^+(MAX) = 1.2\text{mA} \cdot 60\text{V} = 72\text{mW}$$

$$P_{OUT(MAX)} = I_{OUT} \cdot V^+(MAX) = 1\text{mA} \cdot 60\text{V} = 60\text{mW}$$

$$\theta_{JA} = 300^\circ\text{C}/\text{W}$$

$$T_{RISE} = \theta_{JA} \cdot P_{TOTAL(MAX)} = 300^\circ\text{C}/\text{W} \cdot (72\text{mW} + 60\text{mW}) = 39.6^\circ\text{C}$$

$$T_{MAX} = T_{AMBIENT} + T_{RISE} = 80^\circ\text{C} + 39.6^\circ\text{C} = 119.6^\circ\text{C}$$

$$P_{TOTAL(MAX)} \approx 132\text{mW} \text{ and the max die temp will be } 119.6^\circ\text{C}$$

$$T_{MAX} \text{ must be } < 150^\circ\text{C}$$

If this same circuit must run at 125°C , the maximum die temperature will exceed 150°C . (Note that supply current, and therefore P_Q , is proportional to temperature. Refer to Typical Performance Characteristics.) In this condition, the maximum output current should be reduced to avoid device damage. It is important to note that the LTC6104 has been designed to provide at least $\pm 1\text{mA}$ to the output when required, and can deliver more depending on the conditions. Care must be taken to limit the maximum output current by proper choice of sense resistor and, if input fault conditions exist, external clamps.

Output Filtering

The output voltage, V_{OUT} , is simply $I_{OUT} \cdot Z_{OUT}$. This makes filtering straightforward. Any circuit may be used which generates the required Z_{OUT} to get the desired filter response. For example, a capacitor in parallel with R_{OUT} will give a lowpass response. This will reduce unwanted noise from the output, and may also be useful as a charge reservoir to keep the output steady while driving a switching circuit such as a MUX or ADC. This output capacitor in parallel with an output resistor will create a pole in the output response at:

$$f_{-3\text{dB}} = \frac{1}{2 \cdot \pi \cdot R_{OUT} \cdot C_{OUT}}$$

Useful Equations

$$\text{Input Voltage: } V_{SENSE} = I_{SENSE} \cdot R_{SENSE}$$

$$\text{Voltage Gain: } \frac{V_{OUT}}{V_{SENSE}} = \frac{R_{OUT}}{R_{IN}}$$

$$\text{Current Gain: } \frac{I_{OUT}}{I_{SENSE}} = \frac{R_{SENSE}}{R_{IN}}$$

$$\text{Transconductance: } \frac{I_{OUT}}{V_{SENSE}} = \frac{1}{R_{IN}}$$

$$\text{Transimpedance: } \frac{V_{OUT}}{I_{SENSE}} = R_{SENSE} \cdot \frac{R_{OUT}}{R_{IN}}$$

APPLICATIONS INFORMATION

Reverse Supply Protection

Some applications may be tested with reverse-polarity supplies due to an expectation of this type of fault during operation. The LTC6104 is not protected internally from external reversal of supply polarity. To prevent damage that may occur during this condition, a Schottky diode should be added in series with V^- (Figure 6). This will limit the reverse current through the LTC6104. Note that this diode will limit the low voltage performance of the LTC6104 by effectively reducing the supply voltage to the part by V_D . Keep this in mind when choosing an output resistor and voltage reference.

In addition, if the output of the LTC6104 is wired to a device that will effectively short it to high voltage (such as through an ESD protection clamp) during a reverse supply condition, the LTC6104's output should be connected through a resistor or Schottky diode (Figure 7).

Response Time

The LTC6104 is designed to exhibit fast response to inputs for the purpose of circuit protection or signal transmission. This response time will be affected by the external circuit in two ways: delay and speed.

For unidirectional applications, if the output current is very low and an input transient occurs, there may be an increased delay before the output voltage starts to change. This can be improved by increasing the minimum output current, either by increasing R_{SENSE} or by decreasing R_{IN} . The effect of increased output current is illustrated in the step response curves in the Typical Performance Characteristics section of this datasheet. Note that the curves are labeled with respect to the initial output currents.

For bidirectional applications, there is a delay when output current changes polarity. The delay time can be found in the step response curves in the Typical Performance Characteristics section of this data sheet.

Speed is also affected by the external circuit. In this case, if the input changes very quickly, the internal amplifier and the internal output FET (Figure 1) will attempt to maintain the internal loop, but may be slew rate limited. This results in current flowing through R_{IN} and the internal FET. This current slew rate will be determined by the amplifier and FET characteristics as well as the input resistor, R_{IN} . Using a smaller R_{IN} will allow the output current to increase more quickly, decreasing the response time at the output. This will also have the effect of increasing the maximum output current. Using a larger R_{OUT} will

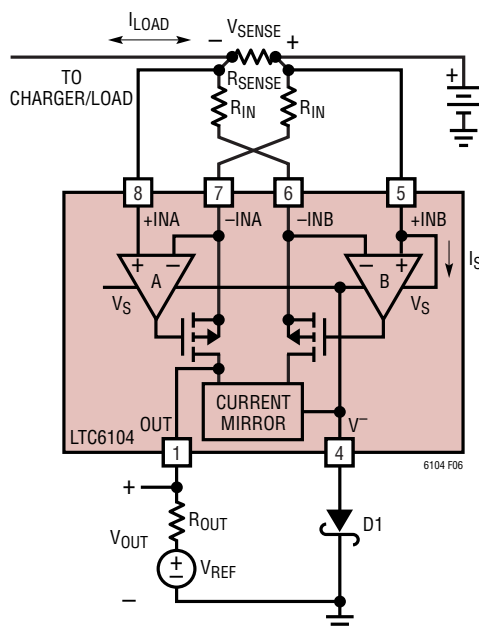

Figure 6. Schottky Prevents Damage During Supply Reversal

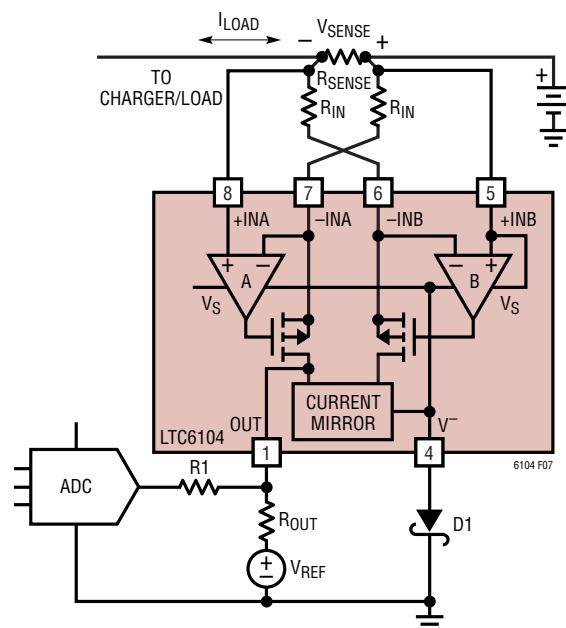

Figure 7. Additional Resistor R1 Protects Output During Supply Reversal

APPLICATIONS INFORMATION

decrease the response time, since $V_{OUT} = I_{OUT} \cdot R_{OUT}$. Reducing R_{IN} and increasing R_{OUT} will both have the effect of increasing the voltage gain of the circuit.

Use of Dual Sense Resistors

The dual amplifier topology offers significant advantages for controlling gain, dynamic range and shunt current. As an example, separate shunt resistors can be advantageous for an H-bridge current monitor (see H-Bridge Load Current Monitor application). It can also be a significant advantage for battery-operated systems, where battery discharge and charge current can be significantly different. With different current range requirements, a “charge shunt resistor” can be connected from the charger to the battery and a separate “discharge shunt resistor” can be connected from the battery to the load. Other applications can benefit from similar topologies where different shunt resistors enable the user to trade off accuracy and shunt power consumption. Finally, since each amplifier has an independent input resistor, gain for each channel can be set to suit the application. The only limitation to observe in this type of application is that since the power for both

sense amplifiers is furnished via the +INB pin, the input protection for both sections is referenced to this one pin. Normal operation of section A is maintained for +INA and -INA voltages within the range of 0.5V above +INB to 1.5V below +INB. As long as both sense resistors are connected to a common potential and voltage drops are small (like <500mV, for example), as in Figure 8 or the H-bridge application, this condition will be met.

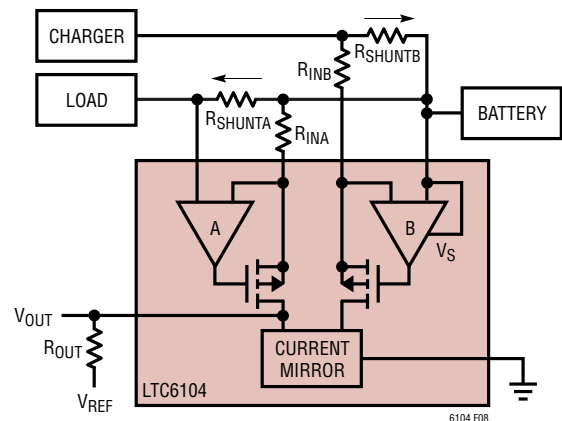
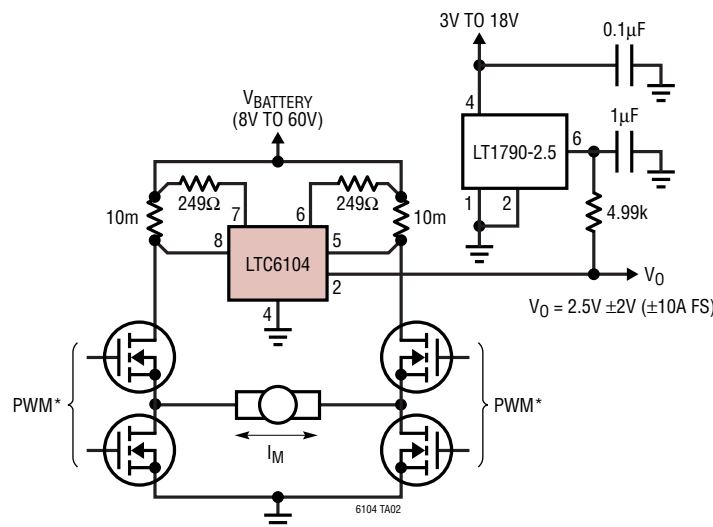

Figure 8

TYPICAL APPLICATION

H-Bridge Load Current Monitor



*USE “SIGN-MAGNITUDE” PWM FOR ACCURATE LOAD CURRENT CONTROL AND MEASUREMENT

PACKAGE DESCRIPTION

MS8 Package
8-Lead Plastic MSOP
 (Reference LTC DWG # 05-08-1660)

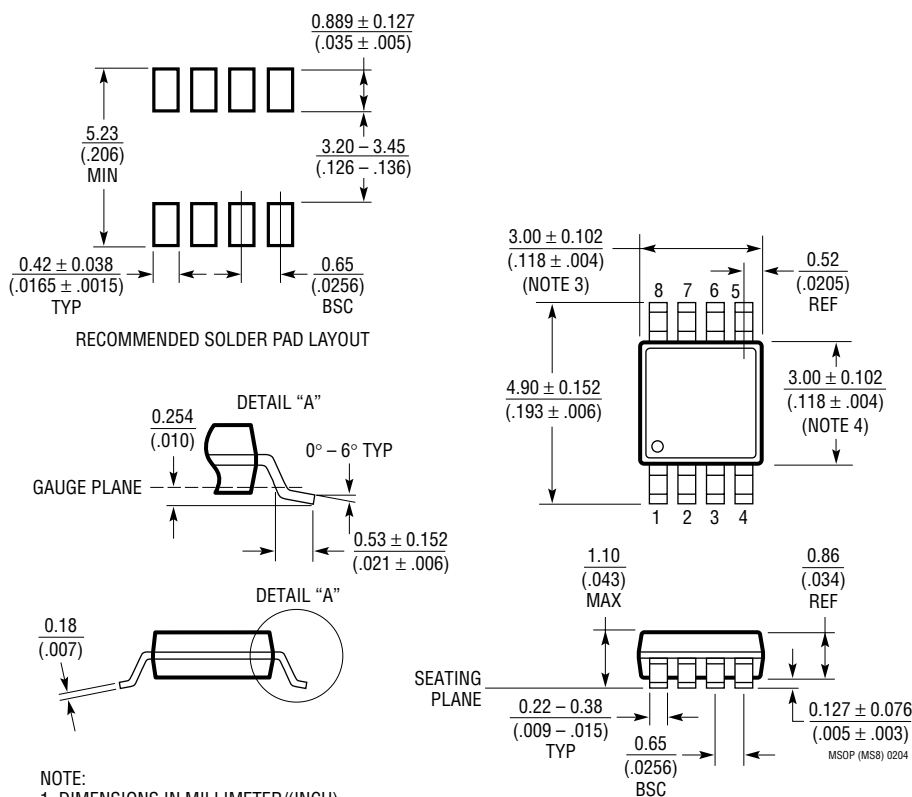

NOTE:

1. DIMENSIONS IN MILLIMETER/(INCH)
2. DRAWING NOT TO SCALE
3. DIMENSION DOES NOT INCLUDE MOLD FLASH, PROTRUSIONS OR GATE BURRS.
MOLD FLASH, PROTRUSIONS OR GATE BURRS SHALL NOT EXCEED 0.152mm (.006") PER SIDE
4. DIMENSION DOES NOT INCLUDE INTERLEAD FLASH OR PROTRUSIONS.
INTERLEAD FLASH OR PROTRUSIONS SHALL NOT EXCEED 0.152mm (.006") PER SIDE
5. LEAD COPLANARITY (BOTTOM OF LEADS AFTER FORMING) SHALL BE 0.102mm (.004") MAX