

DESCRIPTION

Demonstration circuit 1315 features the LT[®]3475-1 dual step-down 1.5A LED driver in a 16-lead TSSOP thermally enhanced package. The demonstration circuit is designed to drive two 1.5A LED strings (one on each channel) from a high input voltage. The high switching frequency scheme permits the use of a small inductor and ceramic capacitors to save space and cost. The current mode PWM control scheme provides fast transient response and cycle-by-cycle current limiting. DC1315 is specifically designed for high power LED applications such as automotive and avionic lighting, architectural detail lighting and display backlighting. See the LT3475-1 datasheet for more detailed information on LED brightness and dimming control using both the PWM pin function and the V_{ADJ} pin function. The PWM terminals can be used to dim the LEDs with the

addition of a PWM MOSFET and the resistor-short connection from LED- to GND removed.

The efficiency of DC1315A with 20V input and 4 white LEDs on each 1.5A channel is 91.5%.

NOTE: The input voltage is limited to 30V during startup. During normal (non-startup) operation, the input voltage can be as high as 36V. DC1315 allows LED string voltages up to 23V. However, some combinations of V_{IN}, V_{LED}, and I_{LED} can result in the LT3475-1 getting hot. Please consult the datasheet for thermal calculations and details. The voltages, the LED current, and the switching frequency can be adjusted for optimal thermal performance.

Design files for this circuit board are available. Call the LTC factory.

LT is a registered trademark of Linear Technology Corporation

QUICK START PROCEDURE

DC1315 is easily set up for evaluating the LT3475-1 dual step-down 1.5A LED driver circuit. Follow the test procedure outlined below and see Figure 1.

1. Connect a bench supply with power OFF to the V_{IN} and GND terminals.
2. Connect a 1.5A LED string with forward voltage >13V to the LED1+ and LED1- terminals.
3. Connect a 1.5A LED string with forward voltage >13V to the LED2+ and LED2- terminals.

NOTE: The boost circuitry on DC1315 is designed to work best with V_{LED} >13V since there is a 9V zener diode limiting the boost voltage. If lower voltage LED strings are required, please lower the voltage of the zener

diode or use another boost method. Please see the datasheet for details.

4. Turn on the input power supply and set the voltage above the LED string voltage and below 30V.
5. Observe the LEDs working properly at 1.5A without looking straight at the LEDs. The brightness is harmful to the eye.

QUICK START GUIDE FOR DEMONSTRATION CIRCUIT 1315

DUAL STEP-DOWN 1.5A LED DRIVER

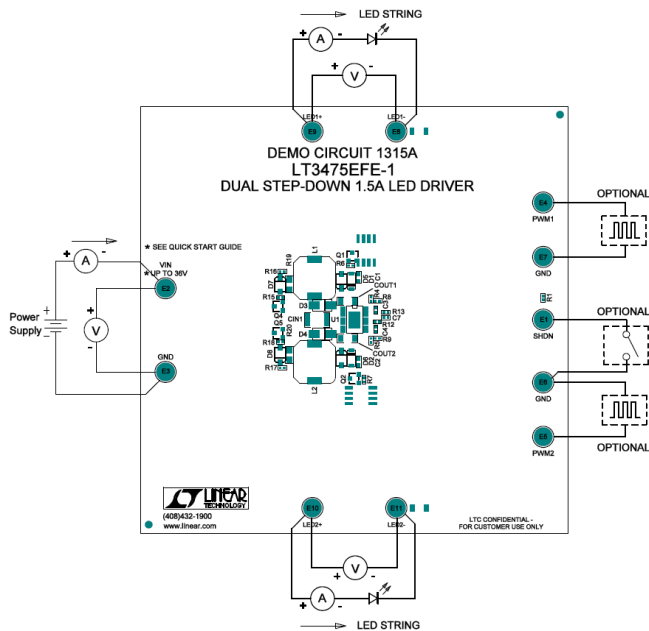

Figure 1. Proper Measurement Equipment Setup

INPUT VOLTAGE RANGE

The operating input voltage range for the LT3475-1 IC is 4V to 36V with an absolute maximum rating of 40V. Under some conditions, it is not recommended to run the IC up to 36V non-transient DC voltage. Please see the datasheet for input voltage range calculations based on switching frequency, LED output voltage, and compensation network topology during startup. As assembled, the DC1315 should not be started up above 30V DC input without first assembling the C-R-C compensation network as shown in the datasheet or using a bigger inductor with up to 3.2A capability in order to maintain control of the switch current.

PWM DIMMING

DC1315 is assembled to show a combination of the most basic operation of the IC and the small solution size. The optional PWM dimming MOSFETs (Q1, Q2) are not stuffed on DC1315, but there are two SOT23 spaces designated for these

to be added to the board. The LED- to GND resistor-short connections (R2, R3) must be removed from the board to enable PWM dimming when the PWM dimming MOSFETs are stuffed with their gate pull-down resistors (R6, R7).

EXTENDED PWM DIMMING

The PWM dimming range can be extended by adding the components Q3, R13, and C7 to the circuit as shown in the datasheet. Q3 is located on the back of the PCB near the PWM terminal. The datasheet describes the calculation of maximum PWM dimming range with and without the extended dimming range components. When these components are added to the circuit, the PWM1 signal is directly connected to the extended dimming range components. If both channel 1 and channel 2 are being used in PWM dimming mode and the extended dimming range circuit is used, the PWM2 signal must be synchronized with the PWM1 signal. The rising edges must occur at the same time although their duty cycles may vary. Failure to do this may result in significant jitter on the second channel or limited PWM dimming range. Please note that a C-R-C compensation network may also help provide the highest pwm dimming range as shown in the datasheet.

LED STRINGS

DC1315 is assembled with optimized components for driving four white LEDs at 1.5A on each of its two channels from an input voltage of 20V. The LEDs are not assembled on the PCB and should be attached to the LED terminals as shown in Figure 1. If the LEDs are not attached, DC1315 will protect itself and survive an open LED condition.

If a different number of LEDs is attached in series to either output, the inductor size, switching frequency, and/or input voltage range may need to be adjusted for proper operation. Consult the datasheet for proper sizing of the inductor for given input and output voltage conditions. The

QUICK START GUIDE FOR DEMONSTRATION CIRCUIT 1315

DUAL STEP-DOWN 1.5A LED DRIVER

maximum LED output voltage is 23V as defined by the external clamp voltage. This limits the number of LEDs in series on the output and sets the open LED maximum output voltage.

Please note the zener diode in the boost path. The 9V zener diode reduces the boost voltage by 9V from the LED (output) voltage. A minimum of 3V is

required on the boost voltage capacitor for proper operation. Please consult the datasheet for details regarding the boost circuit in relation to the input voltage, output voltage, thermals, and maximum ratings.