

LTC3577-3 and LTC3577-4 Highly Integrated Portable Product PMIC

DESCRIPTION

WARNING!

Do not look directly at operating LED.

This circuit produces light that can damage eyes.

Demo Circuit 1592A is a Highly Integrated Portable Product PMIC with a pushbutton controller, two LDOs, three buck converters, a Li-Ion battery charger, and a power path controller featuring the LTC3577-3 and LTC3577-4. This board utilizes a DC590B, USB to I²C interface board, to control the LTC3577-3/LTC377-4 software control window.

The LTC3577-3 and LTC3577-4 are PowerPath™ manager with automatic load prioritization, battery charger, Bat-Track™ controller, push button controlled power up

sequence and reset, and a 10 LED string controller with gradation and PWM control. The three buck regulators and the LED Boost controller have adjustable slew rates for EMI reduction.

The LTC3577-3 and LTC3577-4 has a high temperature battery voltage reduction feature that reduces the battery voltage under high temperature conditions to improve safety and reliability.

Refer to the LTC3577-3 and LTC3577-4 datasheet for more details on the electrical and timing specifications.

Design files for this circuit board are available. Call the LTC factory.

LT, LTC, LTM, LT are registered trademarks of Linear Technology Corporation. PowerPath and Bat-Track are trademarks of Linear Technology Corporation. All other trademarks are the property of their respective owners.

PERFORMANCE SUMMARY Specifications are at T_A = 25°C

PARAMETER	CONDITIONS	MIN	TYP	MAX	UNITS
Input Supply Range (V _{BUS})		4.35		5.5	V
Absolute Wall Input Threshold (V _W)	V _{WALL} Rising		4.3	4.45	V
	V _{WALL} Falling	3.1	3.2		V
DV _{CC} Operating Voltage		1.6		5.5	V
DV _{CC} UVLO (V _{DVCC,UVLO})			1		V
V _{BAT} Regulated Output Voltage (V _{FLOAT})	DC1592A-A (LTC3577-3)	4.179	4.200	4.221	V
	DC1592A-B (LTC3577-4)	4.079	4.100	4.121	V
Constant Current Mode Charge Current (I _{CHRG})	R _{PROG} = 2KΩ, Input current limit = 1A	465	500	535	mA
V _{OUT} UVLO	V _{OUT} Falling	2.5	2.7		V
	V _{OUT} Rising		2.8	2.9	V
V _{OUT1}	0 to 500mA		1.8		V
V _{OUT2}	0 to 500mA		3.3		V
V _{OUT3}	0 to 800mA		1.2		V
LDO1	0 to 150mA		3.3		V
LDO2	0 to 150mA		1.2		V
Full-Scale LED Current			20		mA

QUICK START PROCEDURE

Demo Circuit 1592 is designed to be used with a USB input and/or a 5V adaptor input. Demo Circuit 1592 utilizes the DC590B, USB to I²C interface board, to control the LED boost driver, LDO enables, and buck modes. It is also used to monitor the buck and LDO outputs, plus battery charger status. This circuit may be evaluated using a lithium ion battery or a battery simulator consisting of a 0V-5V, 3A power supply and a 3.6 Ω power resistor.

The DC1592 is easy to set up to evaluate the performance of the LTC3577-3 and LTC3577-4. Refer to Figure 1 and Figure 2 for proper measurement equipment setup and follow the procedure below to evaluate using the DC590B board:

NOTE. When measuring the input or output voltage ripple, care must be taken to avoid a long ground lead on the oscilloscope probe. Measure the input or output voltage ripple by touching the probe tip directly across the VUSB, WALL, or VOUT and GND terminals. See Figure 2 for proper scope probe technique.

1. Refer to the DC590B Quick Start Guide for QuikEval™ setup and software installation details.
2. Set the VCCIO jumper, JP6, on the DC590B board to the 3.3V position.

NOTE. The DVCC voltage level may be selected on the DC590B. This is done by setting the VCCIO jumper, JP6, on the DC590B board to one of the following settings: 3.3V, 5V, removed for 2.7V or set to external if an external supply is desired to be used.
3. Make sure the USB cable is connected between the computer and the DC590B controller board.
4. Set the jumpers on the DC1592 board to the following settings:
 - JP1. ILIM0 to “0” position.
 - JP2. ILIM1 to “0” position.
 - JP3. NTC to “INT” position.
 - JP4. PWR_ON CNTL to “SW” position.
 - JP5. VINLDO2 to “VOUT” position.
5. Connect DC1592 to the DC590B USB Serial Controller using the supplied 14-conductor ribbon cable as shown in Figure 1.

6. With power off, connect a 5V, 1A power supply to VUSB and GND with a series ammeter and a voltmeter as shown in Figure 1.
7. Connect a battery or a battery simulator set to 3.6V between BAT and GND with a series ammeter and a voltmeter as shown in Figure 1.
8. Turn on and set the VUSB input power supply to 5V. The DC590B board gets its power from the USB cable.
9. Run the QuikEval.exe program. The LTC3577-3/LTC3577-4 control window (shown in Figure 3) pops up.

NOTE. The Status indicators on the software control window may display “N/A” when an I²C ACK was not received. This occurs when the part is in the power down (PDN) state or when DVCC is missing. Please refer to the LTC3577 datasheet for more information on the PDN state.

10. On the LTC3577-3/LTC3577-4 control window, select the PWR_ON HI/LOW button. When “HI” is indicated on the button, the PWR_ON pin goes high and the LDO2, VOUT1, and VOUT2 outputs sequence up. VOUT POWER GOOD for each output is indicated on the STATUS section on the control window.
11. On the LTC3577-3/LTC3577-4 control window, select the EN3 HI/LOW button. When “HI” is indicated on the button, the EN3 pin goes high and the VOUT3 powers up. VOUT POWER GOOD for VOUT3 is indicated on the STATUS section on the control window.
12. On the LTC3577-3/LTC3577-4 control window, select the BUCK1 through BUCK3 MODE buttons to switch the bucks into Burst mode. Observe the output ripple and the quiescent current before and after switching modes.
13. Select the desired BUCK SW SLEW RATE option button to switch between a fast rise-time for best efficiency to a slower rise time with better EMI performance.
14. Set the LED DAC REG vertical slider to a desired current level. The LED current and the LED DAC register setting are displayed in the test boxes below the vertical slider. The LED full scale current (I_{LED(FS)}) for this circuit is 20mA.

$$I_{LED} = I_{LED(FS)} \cdot 10^{\left(3 \cdot \frac{DAC - 63}{63}\right)}$$

$$I_{LED(FS)} = \frac{0.8V}{R18} \cdot 500$$

15. Select the LED EN/DIS button to turn on the LEDs. Select the button again to turn off the LEDs.
16. Select the “460ms” GRADATION TIME option button then select the LED EN/DIS button. Observe how the LEDs turn on and off smoothly when the LED boost circuit is enabled and disabled.
17. Select the “PWM” LED MODE option button. This allows the LED intensity to be adjusted with the PWM controls as well as the DAC register.
18. Set the “PWM Numerator” and the “PWM Denominator” vertical sliders to their maximum position. The hexadecimal value of “F” is displayed in the setting text boxes below the sliders. The PWM duty cycle and frequency are also displayed below the setting text boxes.

$$\text{Duty Cycle} = \frac{PWMNUM}{PWMDEN}$$

$$\text{Frequency} = \frac{PWMCLK}{PWMDEN}$$
19. With the LED boost enabled, reduce the “PWM Numerator” vertical slider while observing the LED intensity. Notice that the LEDs dim as the numerator is decreased.
20. Select a different “PWM Clock Speed” option button and observe the PWM frequency changes accordingly.
21. Set the WALL input, PS1, to 5V. Observe that the input current is now coming from the WALL input instead of the VUSB input and VOUT.
22. Refer to the “USING THE LTC3577-3/LTC3577-4 SOFTWARE” section for more information on how to

control the device using the LTC3577-3/LTC3577-4 control window.

23. Set the “PWR_ON CNTL” jumper, JP4, to the “PB” position to power up/down the device with the “ON” pushbutton, PB1.
24. Depress the “ON” pushbutton, PB1 (minimum of 400ms). LDO2, VOUT1, and VOUT2 outputs sequence up. If EN3 HI/LOW button is in the “HI” position, VOUT3 will also power up. VOUT POWER GOOD for each output is indicated on the STATUS section on the control window.
25. Wait at least five seconds from depressing PB1, then depress the “PWR_ON” pushbutton, PB2. LDO2, VOUT1, and VOUT2 (VOUT3 if powered up) outputs shutdown.
26. Again depress PB1, the “ON” pushbutton. LDO2, VOUT1, and VOUT2 outputs sequence up.
27. Wait at least five seconds from depressing PB1, and then depress and hold PB1 for at least 14 seconds. PGOOD will transition low for 1.8ms to allow the microprocessor to reset.
28. The input current limit may be adjusted by changing the “ILIM0” and “ILIM1” jumpers, JP1 and JP2 respectively. See Table 1 for details.

Table 1. Input Current Limit Settings

ILIM1	ILIM0	CURRENT LIMIT
0	0	100mA (1X)
0	1	1A (10X)
1	0	0.5mA (SUSP)
1	1	500mA (5X)

29. Refer to the LTC3577-3 and LTC3577-4 datasheet for more details on how the LTC3577 operates.
30. When done, turn off all loads and power supplies and then close the LTC3577-3/LTC3577-4 control window.

LTC3577-3 AND LTC3577-4

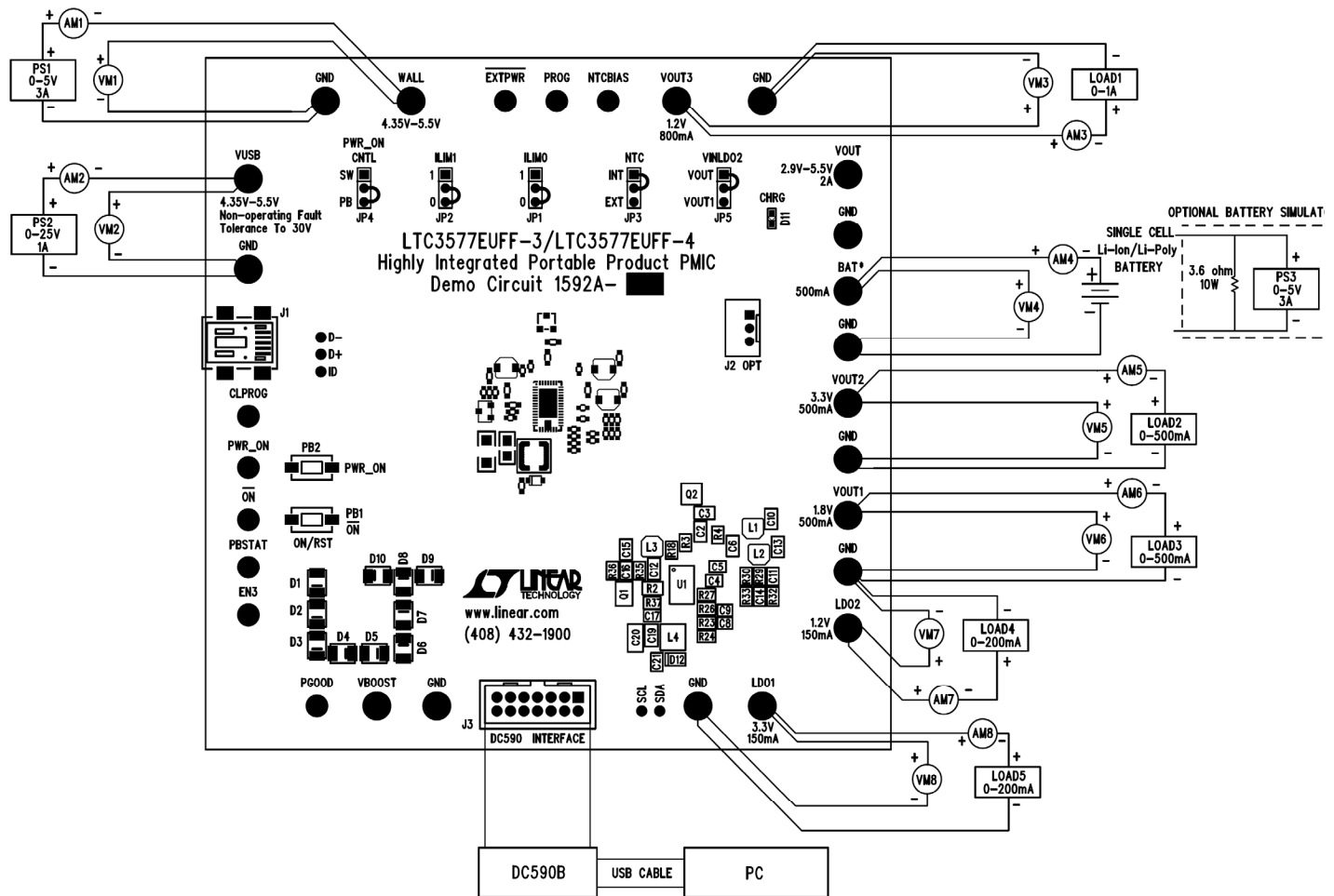

Proper Measurement Equipment Setup

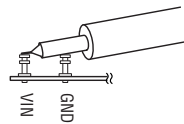

Figure 1. Measuring Input or Output Ripple

USING THE LTC3577-3/LTC3577-4 SOFTWARE

The LTC3577-3/LTC3577-4 program provides control of the mode and slew rate of the buck regulators. It also controls the intensity and slew rate of the LED boost controller and allows the user to view the contents of the status register.

VIEW LTC3577 PRODUCT PAGE button opens an internet browser and searches the Linear Technology Corporation web site for information on the LTC3577 when an internet connection is available.

REG0 through **REG3** text box windows display the hexadecimal value that has been written to the corresponding registers of the LTC3577-3/LTC3577-4.

STATUS REG text box window displays the hexadecimal value that has been last read from the LTC3577-3/LTC3577-4 status register.

BUCK1 through **BUCK3 MODE** select buttons are used to individually set each buck regulator into Pulse Skip Mode or Burst Mode for light loads.

BUCK SW SLEW RATE option buttons are used to choose one of four slew rates for optimal EMI reduction or efficiency.

PWR_ON HI/LOW select button is used to set the PWR_ON pin high or low to turn on or off LDO2, VOUT1, and VOUT2.

EN3 HI/LOW select button is used to set the EN3 pin high or low to turn on or off VOUT3.

AUTO READ BACK ENABLED/DISABLED select button is used to automatically update the status register every 250ms when enabled. When disabled the read register may be updated by selecting the “Read Back Status” button.

Read Back Status button is used to update the status register when selected.

AUTO UPDATE ENABLED/DISABLED select button is used to automatically update the LTC3577-3/LTC3577-4 I²C registers when any of the Buck or LED buttons or sliders have been changed. When disabled the LTC3577-3/LTC3577-4 I²C registers may be updated by selecting the “Update All Registers” button.

Update All Registers button is used to update all of the LTC3577-3/LTC3577-4 I²C write registers when selected.

LED EN/DIS select button is used to enable or disable the LED boost controller.

BOOST SW SLEW RATE FAST/SLOW button is used to turn on and off the LED switch faster or slower for optimal efficiency or EMI reduction.

LED MODE option buttons are used to choose one of three Boost controller modes. CC Boost mode is a constant current mode that allows the LED current to be controlled by the LED DAC REG vertical slider. HV Boost mode regulates the ILED pin to 0.8V to operate the Boost at a fixed voltage. **HV Boost mode should not be enabled unless the demo circuit has been modified to support this mode of operation.** PWM mode allows the LED intensity to be controlled by pulse width modulating the LEDs based on the LED DAC REG, PWM Numerator, PWM Denominator, and PWM Clock Speed settings.

NOTE: When in CC Boost or HV Boost LED modes, the PWM controls are disabled.

GRADATION TIME option buttons set the desired time to gradate up to or down from the selected LED intensity whenever the LED controller is enabled or disabled.

LED DAC REG vertical slider controls the LED current from 20uA to 20mA in 64 logarithmic steps. The LED intensity slider may be adjusted by clicking on the up or down arrows to increment or decrement by one LSB or by clicking and dragging the slide pointer. The hex code and LED current is displayed in the two text boxes below the slider.

PWM Clock Speed option buttons are used to select the PWM clock speed. The PWM clock speed is divided by the PWM denominator to determine the PWM frequency.

PWM Numerator vertical slider is used to select a PWM numerator value. The PWM numerator is divided by the PWM denominator to determine the PWM duty cycle.

PWM Denominator vertical slider is used select a PWM denominator value. The PWM denominator is used in conjunction with the PWM numerator to determine the PWM duty cycle and with the PWM clock speed to determine the PWM frequency.

STATUS indicators display the charge, NTC, and power status determined by the LTC3577-3/LTC3577-4 status register.

LTC3577-3 AND LTC3577-4

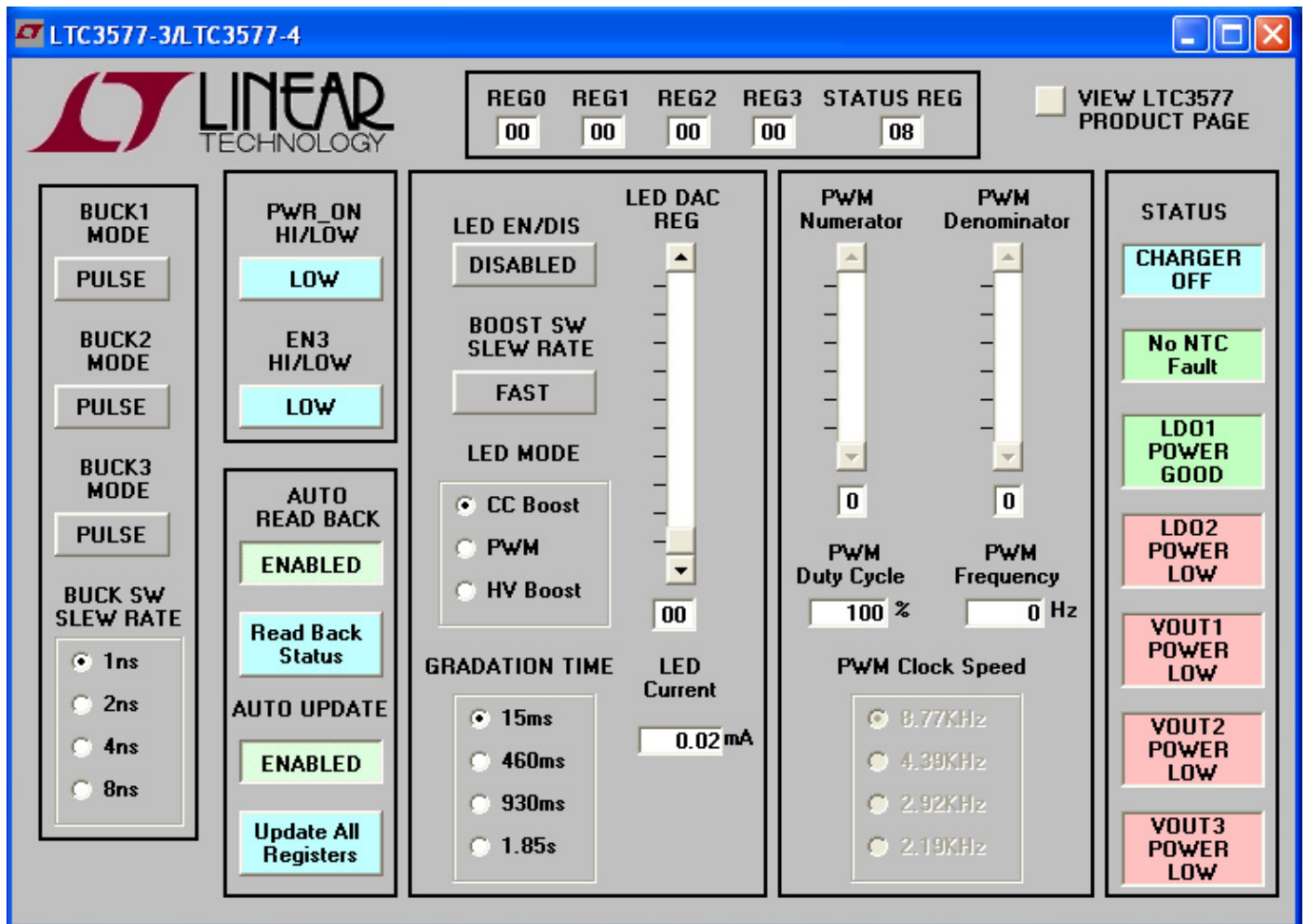
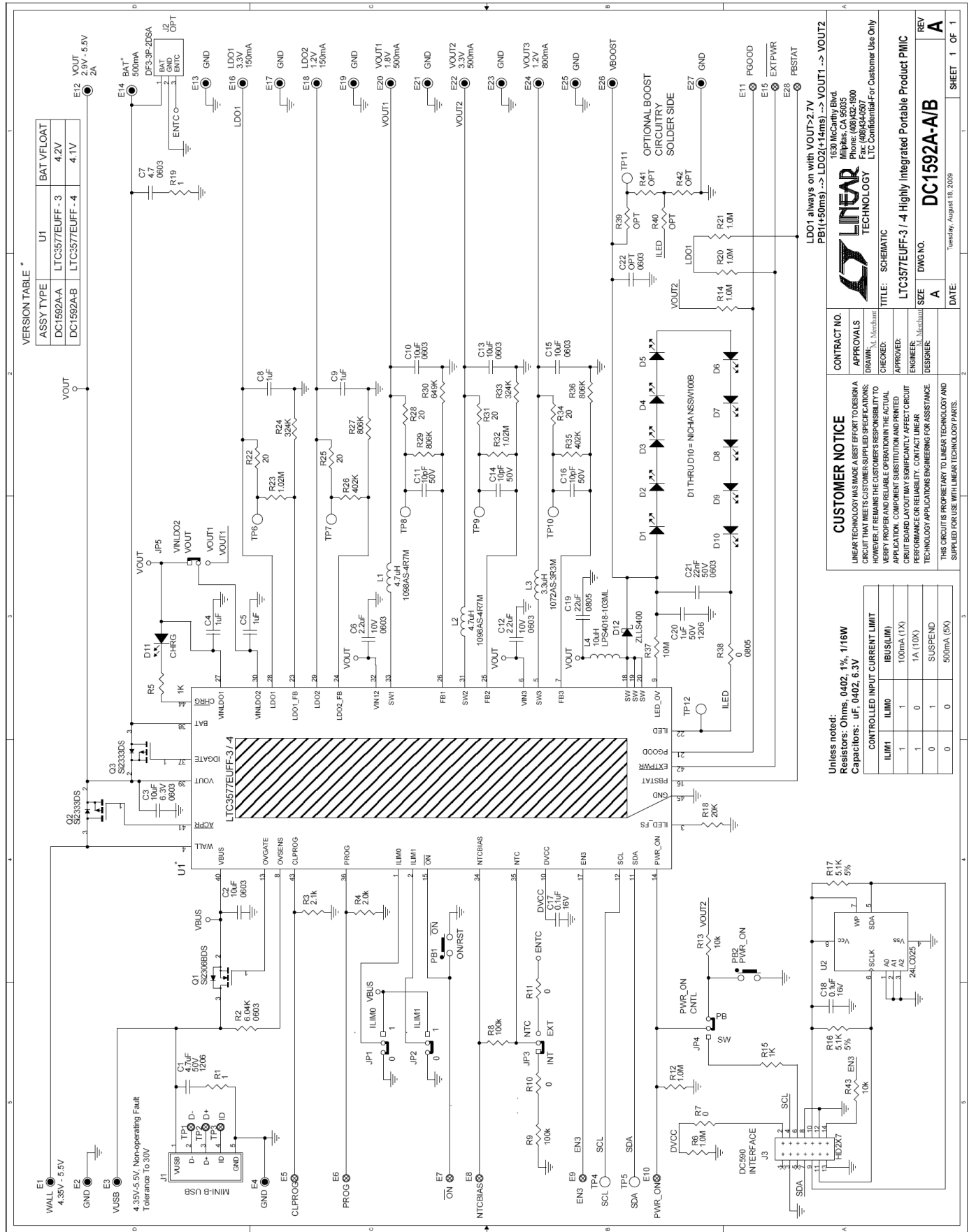

Figure 2. LTC3577-3/LTC3577-4 Software Control Window

LTC3577-3 AND LTC3577-4



VERSION TABLE *

ASSY TYPE	U1	BAT V/FLOAT
DC1592A-A	LTC3577EUFF-3	4.2V
DC1592A-B	LTC3577EUFF-4	4.1V

LINER TECHNOLOGY
 1630 McCammy Blvd.
 Milpitas, CA 95035
 Phone: (408)432-1800
 Fax: (408)434-9097
 LTC Confidential-For Customer Use Only

DC1592A-A/B

DATE: Tuesday, August 18, 2009

CUSTOMER NOTICE
 LINER TECHNOLOGY HAS MADE A BEST EFFORT TO DESIGN A CIRCUIT THAT MEETS CUSTOMER-SUPPLIED SPECIFICATIONS; HOWEVER, IT REMAINS THE CUSTOMER'S RESPONSIBILITY TO VERIFY PROPER AND RELIABLE OPERATION IN THE ACTUAL APPLICATION. COMPONENT SUBSTITUTION AND PRINTED CIRCUIT BOARD LAYOUT MAY SIGNIFICANTLY AFFECT CIRCUIT PERFORMANCE OR RELIABILITY. CONTACT LINER TECHNOLOGY APPLICATIONS ENGINEERING FOR ASSISTANCE AND THIS CIRCUIT IS PROPRIETARY TO LINER TECHNOLOGY AND SUPPLIED FOR USE WITH LINER TECHNOLOGY PARTS.

CONTRACT NO.
 APPROVALS
 DRAWN: M. Merchant
 CHECKED:
 APPROVED:
 ENGINEER: M. Merchant
 DESIGNER:

TITLE: SCHEMATIC
SIZE: A
REV: A

Unless noted:
 Resistors: Ohms, 0402, 1%, 1/16W
 Capacitors: μ F, 0402, 6.3V

CONTROLLED INPUT CURRENT LIMIT	
ILIM1	ILIM0
1	1
0	0
0	0

(BUS/ILIM) 100mA (1X)
 1A (10X)
 SUSPEND
 500mA (5X)

LDO1 always on with VOUT>2.7V
 PB1(+50ms) -> LDO2(+14ms) -> VOUT1 -> VOUT2

OPTIONAL BOOST CIRCUITRY SOLDER SIDE

D1 THRU D10 = NICHIA/NSH100B

TP11

DC590 INTERFACE