

LT3032: Dual 150mA Positive/Negative Low Noise Low Dropout Linear Regulator

DESCRIPTION

Demonstration circuit 1622A is a dual 150mA linear regulator featuring the LT[®]3032. The LT3032 is a dual, positive and negative low dropout linear regulator. Each regulator supplies up to 150mA of output current with a typical 300mV dropout voltage. Each regulator's quiescent current is low (<3 μ A total in shutdown) and well controlled in dropout, making it an excellent choice for battery-powered circuits.

A 0.01 μ F bypass capacitor to each regulator reduces output voltage noise to 20 μ V_{RMS} (positive regulator)/30 μ V_{RMS} (negative regulator) over a 10Hz to 100kHz bandwidth. The LT3032 is stable with minimum output capacitor of 2.2 μ F. The regulators do not require any additional ESR.

Internal protection circuitry includes reverse output protection, current limiting and thermal limiting. Each regulator

is offered as an adjustable output device with an output voltage range down to the ± 1.22 V reference voltages.

The LT3032 is available in a unique low profile 14-lead 4mm \times 3mm \times 0.75mm DFN package with exposed back-side pads for each regulator.

The LT3032 data sheet gives a complete description of the part, operation and application information. The data sheet must be read in conjunction with this quick start guide for demo circuit 1622A.

Design files for this circuit board are available at <http://www.linear.com/demo>

LT, LT, LTC, LTM, μ Module, Linear Technology and the Linear logo are registered trademarks of Linear Technology Corporation. All other trademarks are the property of their respective owners.

PERFORMANCE SUMMARY (T_A = 25°C)

PARAMETER	CONDITION	VALUE
Minimum INP Input Voltage	I _{LOAD} = 150mA	2.3V
Minimum INN Input Voltage	I _{LOAD} = -150mA	-2.3V
Maximum Input Voltage	V _{OUTP} = 5V, I _{LOAD} = -150mA	20V
	V _{OUTN} = -5V, I _{LOAD} = -90mA	-20V
Output Voltage V _{OUT}	J1, J2 Shunt in 7, 8	± 4.989 V $\pm 3\%$
Maximum Output Current	V _{INP} = 7V, V _{OUTP} = 5V	150mA
	V _{INN} = -7V, V _{OUTN} = -5V	-150mA

DEMO MANUAL DC1622A

QUICK START PROCEDURE

Demonstration circuit 1622A is easy to set up to evaluate the performance of the LT3032. Refer to Figure 1 for proper measurement of the equipment setup and follow the procedure below:

1. Place JP1 and JP2 on the ON position.
2. Use OUTP and OUTN selection J1, J2 to set the desired output voltage.
3. With power off, connect the input power supply to \pm VIN and GND.
4. Turn on the power at the input.

Note: Make sure that the input voltage does not exceed $\pm 20V$.

5. Check for the proper output voltage.

Note: If there is no output, temporarily disconnect the load to make sure that the load is not set too high.

6. Once the proper output voltage is established, adjust the load within the operating range and observe the output voltage regulation, efficiency and other parameters.

Note: Make sure that the power dissipation is limited below the thermal limit.

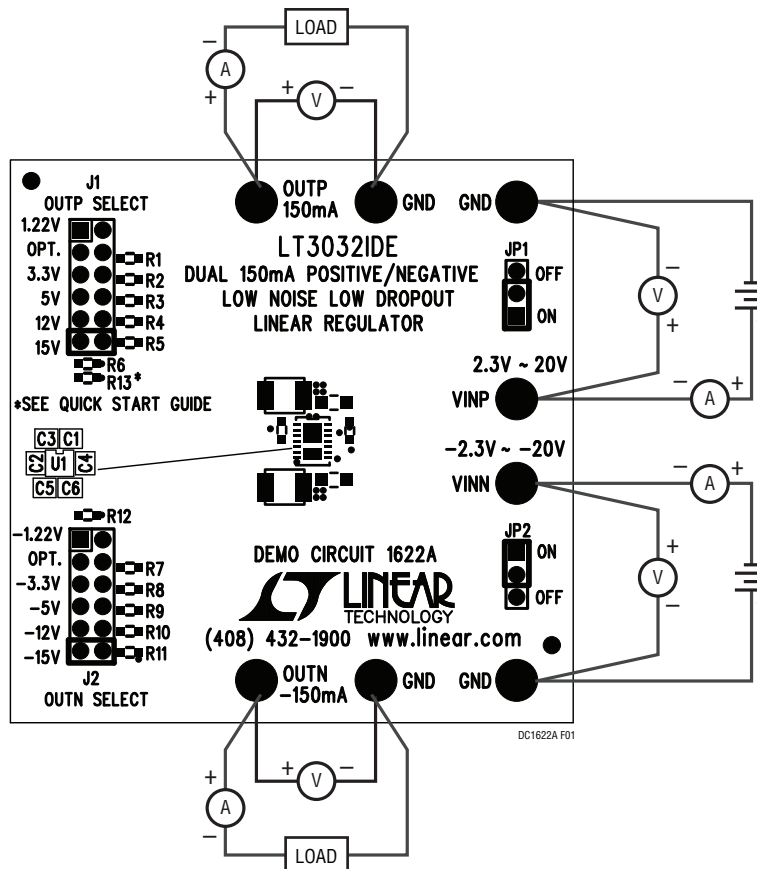

Figure 1. Proper Measurement Equipment Setup

TRACKING POWER SUPPLY DESIGN

The demo board can be modified easily into a tracking supply design. Remove R6, R12 from the board and solder the resistor R13 onto the board. R13 should be less than 250k to minimize errors in the resultant output voltage caused by the ADJP/N pin bias current. The output voltage is:

$$V_{OUTP} = 1.22 + 2.44/R13 \times R_{TOP} (V)$$

$$V_{OUTN} = -1.22 - 2.44/R13 \times R_{BOT} (V)$$

Use a variable resistor in series with a fixed value resistor if the output voltage is adjustable.

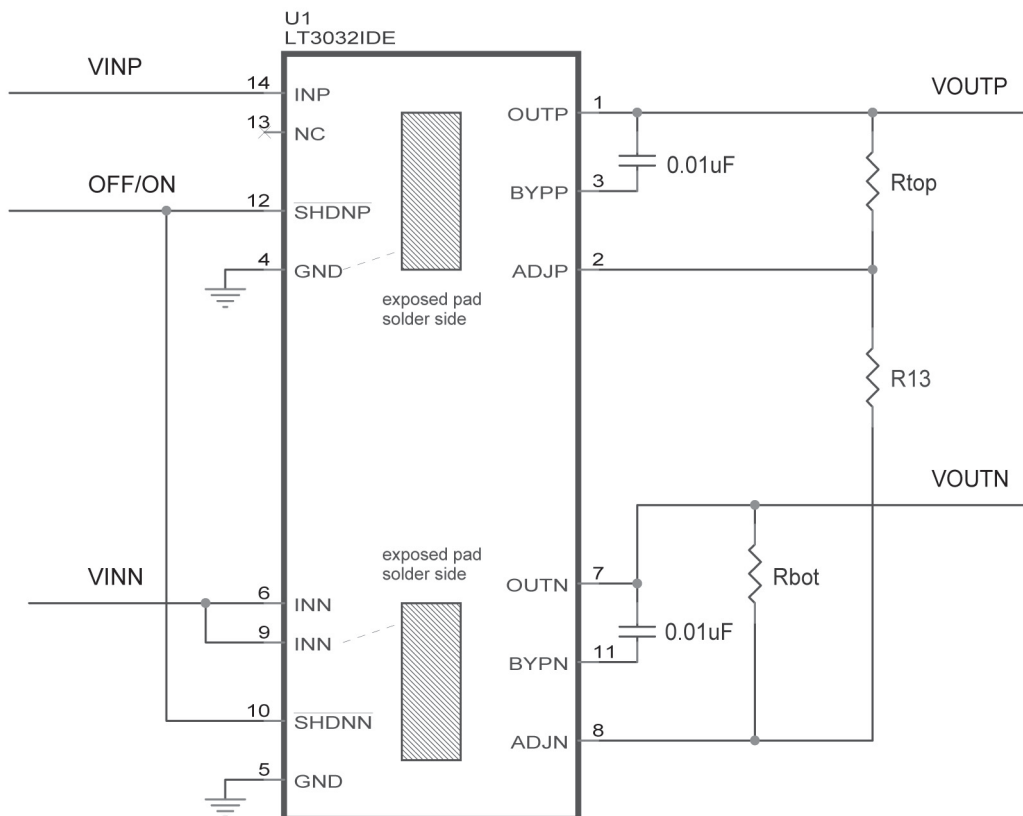

Figure 2. Tracking Power Supply Design

DEMO MANUAL DC1622A

PARTS LIST

ITEM	QTY	REFERENCE	PART DESCRIPTION	MANUFACTURER/PART NUMBER
Required Circuit Components				
1	2	C2, C4	CAP, CHIP X7R, 0.01 μ F, 50V, 0603	TDK, C1608X7R1H103K
2	2	C1, C6	CAP, CHIP X5R, 2.2 μ F, 25V, 0805	AVX, 08053C225KAT2A
3	2	C3, C5	CAP, CHIP X7R, 10 μ F, 25V, 1210	TDK, C3225X7R1E106M
4	2	R2, R8	RES., CHIP 150k 1% 0603	VISHAY, CRCW0603150KFKEA
5	2	R6, R12	RES., CHIP 88.7k 1% 0603	VISHAY, CRCW060388K7FKEA
Additional Demo Board Circuit Components				
1	2	R3, R9	RES., CHIP 274k 1% 0603	VISHAY, CRCW0603274KFKEA
2	2	R4, R10	RES., CHIP 787k 1% 0603	VISHAY, CRCW0603787KFKEA
3	2	R5, R11	RES., CHIP 1M 1% 0603	VISHAY, CRCW06031M00FKEA
4	0	R1, R7, R13	OPT.	
Hardware: For Demo Board Only				
1	8	E1-E8	TURRET, TESTPOINT	MILL-MAX, 2501-2-00-80-00-00-07-0
2	2	JP1, JP2	HEADER, 1X3 PINS, 2MM	SAMTEC, TMM-103-02-L-S
3	2	J1-J2	HEADER, 2X6 PINS, 2MM	SAMTEC, TMM-106-02-L-D
4	4	JP1, JP2, J1, J2	SHUNT	SAMTEC, 2SN-BK-G

SCHEMATIC DIAGRAM

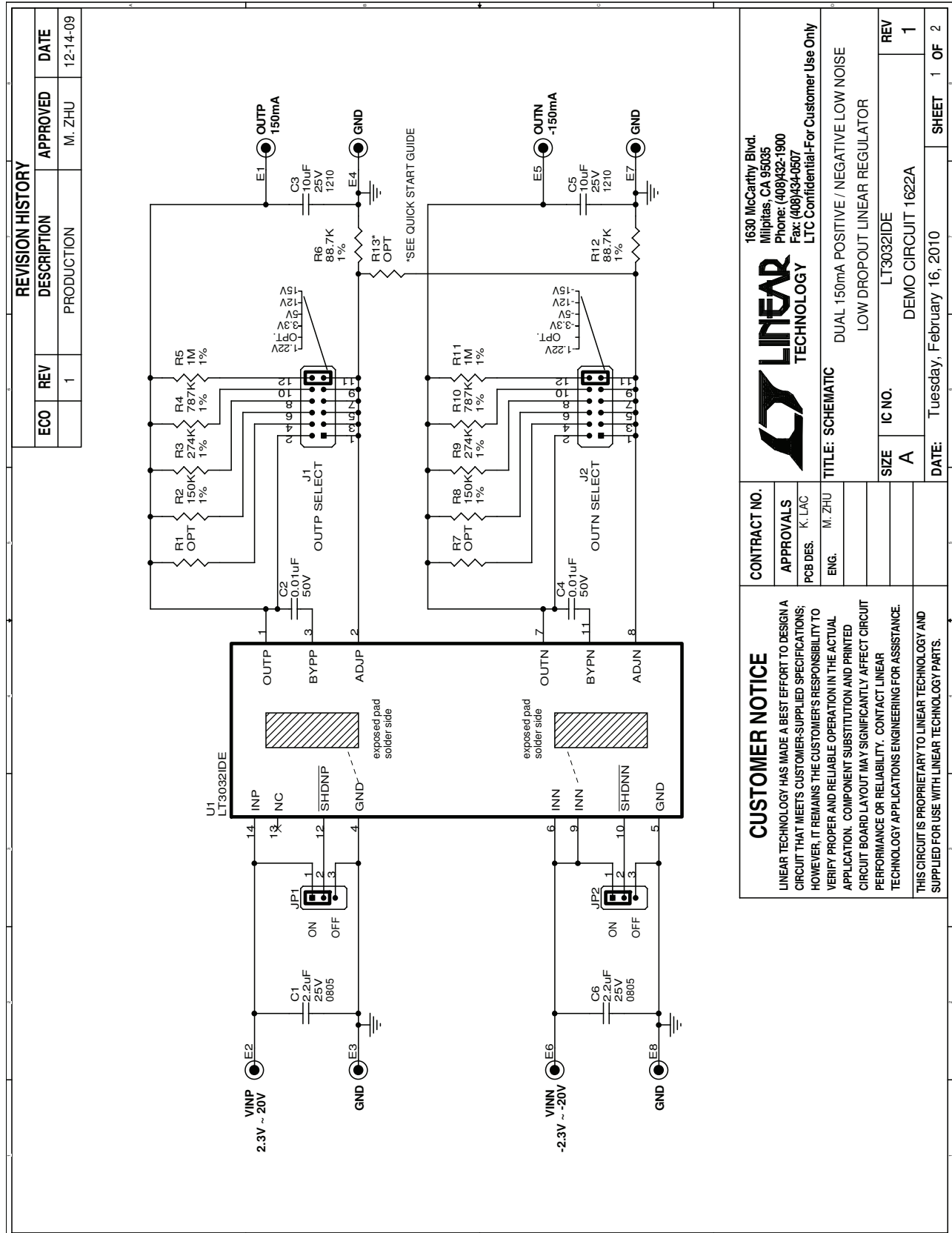

dc1622af