

LT3796

100V LED Controller with Current Monitor

DESCRIPTION

DC1706A is a 100V LED controller with an input current monitor. It is a single switch boost LED driver with LED⁺ to GND short circuit protection. It accepts an input voltage from 8V to 100V (7.5V UVLO and 8.7V turn-on), and drives up to 85V of LEDs at 400mA (when PVIN is less than V_{LED}). DC1706A features both PWM and analog dimming of the LED string. It has a VMODE flag that indicates when the LED string has been removed and it has a FAULT flag that indicates that the output has been shorted to GND. In both cases, the IC remains in control and well protected.

DC1706A features high efficiency at 300kHz switching frequency. At high LED string voltages up to 85V and 400mA of LED current, the single switch controller has 93% efficiency. There are input current (CSOUT) and output current (ISMON) monitor pins that deliver a voltage proportional to the current for quick diagnostics.

Small ceramic input and output capacitors are used to save space and cost. The open LED overvoltage protection uses the IC's constant voltage regulation loop to regulate the output to approximately 92.5V if the LED string is opened although it may reach 96.5V peak during transient from running LEDs to open.

For low input voltage operation, the CTRL pin voltage is reduced as the input voltage drops below 9V, reducing LED brightness and restraining the peak switch currents in order to limit inductor and switch size. UVLO turns the LEDs off when VIN drops below 7.5V.

DC1706A PWM dimming is simple. The topside PWM dimming MOSFET (M2) turns the LED string on and off with an input to the PWM dimming terminal. For the highest PWM dimming ratio, it is recommended to use 100Hz as a PWM dimming frequency. Information regarding PWM dimming ratios and performance can be found in the LT3796 data sheet in the applications section. Analog dimming is also simple to use with a single voltage source on the CTRL terminal.

Modifications can be made to DC1706A in order to convert the board to higher or lower power or from an LED driver to a constant voltage regulator or battery charger. It can easily be changed from a boost topology to a SEPIC, buck mode, or buck-boost mode LED driver. Please consult the factory or refer to the LT3796 data sheet for details.

The LT3796 data sheet gives a complete description of the part, operation and applications information. The data sheet must be read in conjunction with this demo manual for DC1706A. The LT3796 is assembled in a 28-lead plastic TSSOP FE package with a thermally enhanced ground pad. Proper board layout is essential for maximum thermal performance. See the data sheet section Layout Considerations.

Design files for this circuit board are available at <http://www.linear.com/demo>

LT, LT, LTC, LTM, Linear Technology and the Linear logo are registered trademarks of Linear Technology Corporation. All other trademarks are the property of their respective owners.

DEMO MANUAL DC1706A

PERFORMANCE SUMMARY (T_A = 25°C)

PARAMETER	CONDITIONS	UNITS
Input Voltage PVIN Range	Operating	7.5V to V _{LED}
Switching Frequency	R18 = 26.1k	300kHz
I _{LED}	RS2 = 0.62Ω, 9V < PVIN < V _{LED}	400mA
Low PVIN I _{LED} (CTRL Foldback)	RS2 = 0.62Ω, PVIN = 8V	350mA
V _{LED} Range	R5 = 1M, R9 = 13.7k	PVIN < V _{LED} < 85V
Open LED Voltage	R5 = 1M, R9 = 13.7k	92.5V
Typical Efficiency	PVIN = 14V, V _{LED} = 85V, I _{LED} = 400mA	93%
Under Voltage Lockout (Falling Turn-Off)	R1 = 499k and R8 = 100k	7.5V
Under Voltage Lockout (Rising Turn-On)	R1 = 499k and R8 = 100k	8.7V
V _{INTVCC}	Operating	7.7V
Peak Switch Current Limit	RS3 = 0.015Ω	6.6A
Suggested Maximum PWM Dimming Ratio	f _{PWM} = 100Hz, PVIN=12V, V _{LED} = 85V, I _{LED} = 400mA	100:1

QUICK START PROCEDURE

DC1706A is easy to set up to evaluate the performance of the LT3796. Follow the procedure below:

NOTE: PWM must be pulled high to run. If PWM is not used, connect PWM to a 3.3V or 5V source or to VREF on the PCB using 0Ω resistor R24.

1. Connect a string of LEDs that will run with forward voltage less than 85V, but greater than PVIN, to the LED⁺ and GND terminals on the PCB as shown in Figure 1.
2. Connect the EN/UVLO terminal to GND.
3. With power off, connect the input power supply to the PVIN and GND terminals. Make sure that the PVIN DC input voltage will not exceed 100V (or V_{LED}).
4. Connect the PWM terminal. If PWM is not used, connect PWM to a 3.3V or 5V source or to VREF on the PCB using 0Ω resistor R24. PWM must be pulled high to run.
5. Turn the input power supply on and make sure the voltage is between 8V and V_{LED}.
6. Release the EN/UVLO-to-GND connection.
7. Observe the LED string running at the programmed LED current.
8. Observe the CSOUT and ISMON input and output current monitor voltages.
9. For PWM dimming, connect a PWM (100Hz or higher is recommended) signal to the PWM terminal. For analog dimming, connect a DC voltage between 0V and 2V to the CTRL terminal.
10. Observe the reduction of brightness in the LED string when PWM or analog dimming.

QUICK START PROCEDURE

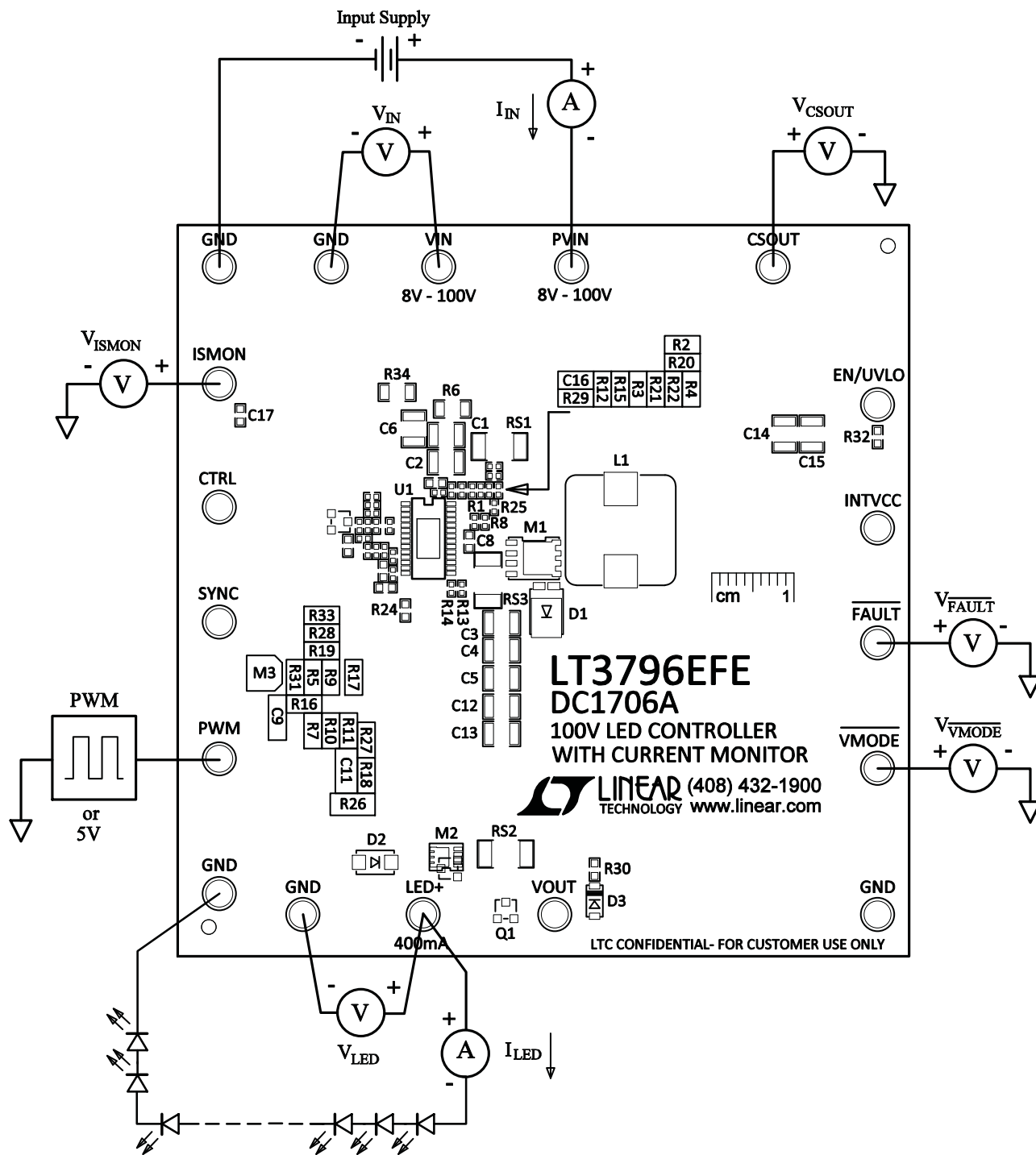
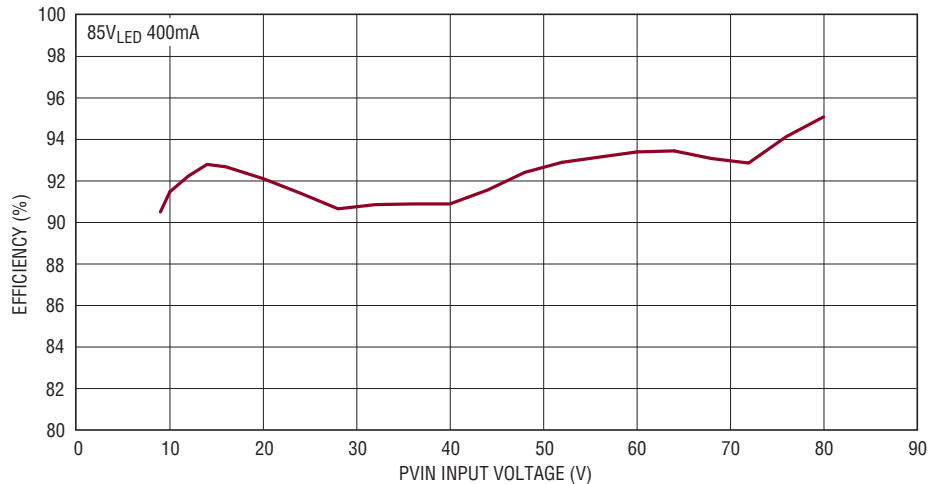

Figure 1. Test Procedure Setup Drawing for DC1706A

QUICK START PROCEDURE



DC1706a F02

Figure 2. DC1706A Efficiency with 85V LEDs at 400mA

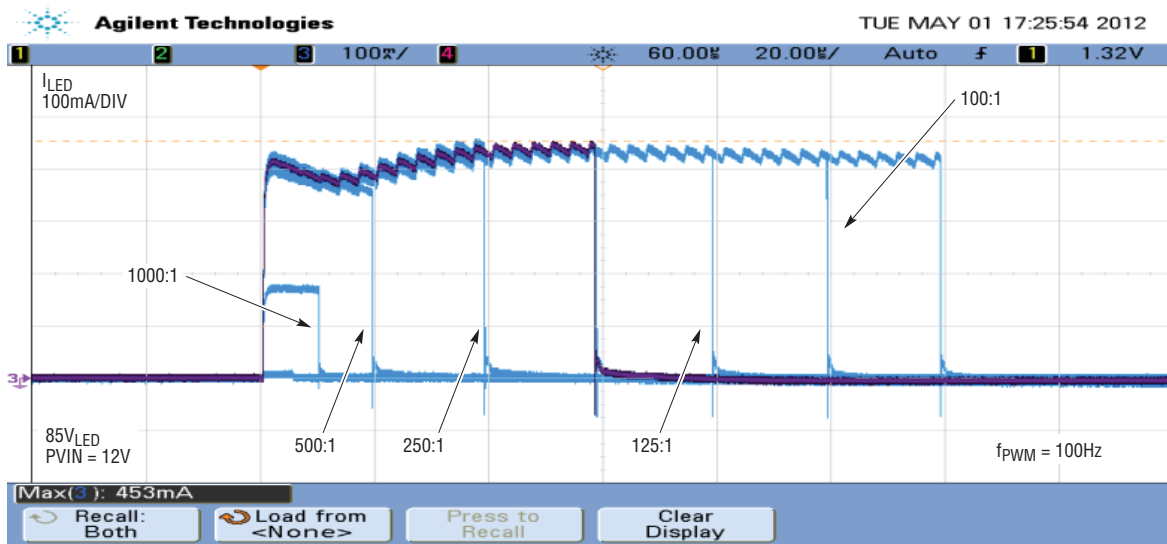

DC1706a F03

Figure 3. DC1706A 100Hz 100:1 to 1000:1 PWM Dimming Waveforms at 12V PVIN and 85V V_{LED}

QUICK START PROCEDURE

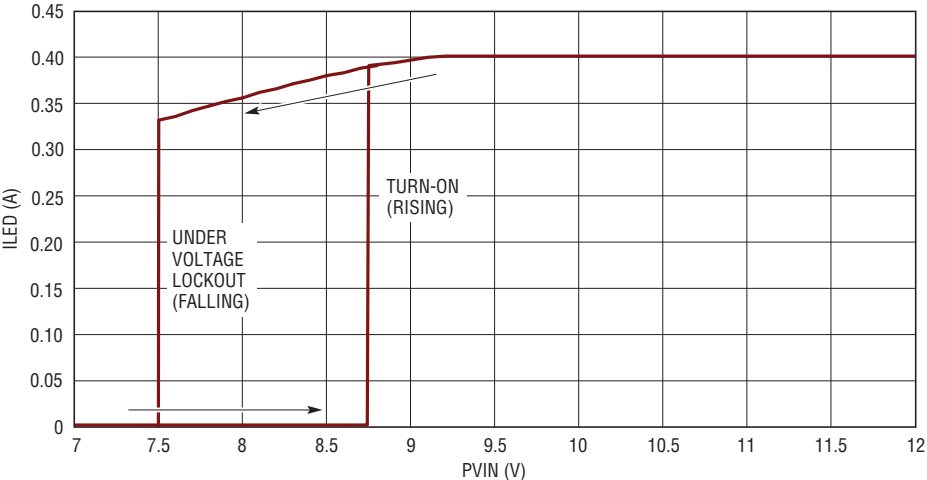

DC1706a F04

Figure 4. DC1706A CTRL LED Current Foldback at Low PVIN with UVLO Falling and Rising

DEMO MANUAL DC1706A

PARTS LIST

ITEM	QTY	REFERENCE	PART DESCRIPTION	MANUFACTURER/PART NUMBER
Required Circuit Components				
1	2	C1, C2	CAP, X7S 4.7 μ F 100V 10% 1210	TDK C3225X7S2A475K
2	5	C3, C4, C5, C6, C12	CAP, X7R 2.2 μ F 100V 10% 1210	MURATA GRM32ER72A225KA35L
3	1	C8	CAP, X5R 4.7 μ F 10V 10% 0603	AVX 0603ZD475KAT2A
4	1	C9	CAP, X7R 0.01 μ F 25V 10% 0603	AVX 06033C103KAT2A
5	1	C11	CAP, X7R 0.1 μ F 25V 10% 0603	AVX 06033C104KAT2A
6	1	D1	SCHOTTKY DIODE 100V 5A POWERDI5	DIODES INC PDS5100H
7	1	L1	INDUCTOR, 22 μ H HC9-SERIES	COOPER BUSSMANN HC9-220-R
8	1	M1	MOSFET N-CHAN, 100V/15A LFPK	RENESAS RJK1051DPB-00-J5 #PbF
9	1	M2	MOSFET P-CHAN, 100V POWERPAK 1212-8	SILICONIX Si7113DN-T1-E3 #PbF
10	1	RS2	RES, LRC 0.620 0.5W 1% 2010	IRC LR2010LF-01-R620-F
11	1	RS3	RES, 0.015 0.5W 1% 2010	VISHAY WSL2010R0150FEA
12	1	R5	RES, CHIP 1M 0.06W 1% 0402	VISHAY CRCW04021M00FKED
13	1	R9	RES, CHIP 13.7k 0.06W 1% 0402	VISHAY CRCW040213K7FKED
14	1	R16	RES, CHIP 4.7k 0.06W 5% 0402	VISHAY CRCW04024K70JNED
15	1	R18	RES, CHIP 26.1k 0.06W 1% 0402	VISHAY CRCW040226K1FKED
16	1	U1	100V LED CONTROLLER IC TSSOP28-FE/EB	LINEAR TECHNOLOGY LT3796
Optional Electrical Components				
1	0	C13, C14, C15	CAP, 1210 OPTIONAL	
2	1	C16	CAP, X7R 0.01 μ F 25V 10% 0603	AVX 06033C103KAT2A
3	1	C17	CAP, X7R 0.1 μ F 25V 10% 0603	AVX 06033C104KAT2A
4	1	D2	SCHOTTKY RECT, 150V/1A SMA	FAIRCHILD SEMI ES1C
5	0	D3	DIODE, SOD-123 OPTIONAL	
6	0	M3	MOSFET SOT23 OPTIONAL	
7	1	Q1	TRANS, PNP SOT23	ZETEX/DIODES INC FMMT589
8	1	RS1	RES, 0.025 0.5W 1% 2010	VISHAY WSL2010R0250FEA
9	1	R1	RES, CHIP 499k 0.06W 1% 0402	VISHAY CRCW0402499KFKED
10	3	R2, R4, R17	RES/JUMPER, CHIP 0 Ω 1/16W 1A 0402	VISHAY CRCW04020000Z0ED
11	1	R3	RES, CHIP 2k 0.06W 1% 0402	VISHAY CRCW04022K00FKED
12	1	R6	RES/JUMPER, CHIP 0 Ω 1/4W 1A 1206	VISHAY CRCW12060000Z0EA
13	1	R7	RES, CHIP 1M 0.06W 1% 0402	VISHAY CRCW04021M00FKED
14	1	R8	RES, CHIP 100k 0.06W 1% 0402	VISHAY CRCW0402100KFKED
15	1	R10	RES, CHIP 137k 0.06W 1% 0402	VISHAY CRCW0402137KFKED
16	0	R11, R12, R15, R19 TO R22, R25, R27, R28, R31, R33	RES 0402 OPTIONAL	
17	2	R13, R14	RES, CHIP 100k 0.06W 5% 0402	VISHAY CRCW0402100KJNED
18	0	R24, R30, R32	RES, 0603 OPTIONAL	
19	1	R26	RES/JUMPER, Chip 0 Ω 1/16W 1A 0603	VISHAY CRCW06030000Z0EA
20	1	R29	RES, CHIP 82.5k 0.06W 1% 0402	VISHAY CRCW040282K5FKED
21	0	R34	RES, 1206 OPTIONAL	
Optional Hardware				
1	18	E1 TO E18	TURRET, TESTPOINT	MILL MAX 2501-2-00-80-00-07-0

SCHEMATIC DIAGRAM

