

High Voltage High Current Controller for Battery Charging and Power Management

FEATURES

- Complete High Performance Battery Charger When Paired with a DC/DC Converter
- Wide Input and Output Voltage Range: 3V to 60V
- Input Ideal Diode for Low Loss Reverse Blocking and Load Sharing
- Output Ideal Diode for Low Loss PowerPath™ and Load Sharing with the Battery
- Instant-On Operation with Heavily Discharged Battery
- Programmable Input and Charge Current: $\pm 1\%$ Accuracy
- $\pm 0.25\%$ Accurate Programmable Float Voltage
- Programmable C/X or Timer Based Charge Termination
- NTC Input for Temperature Qualified Charging
- 28-Lead 4mm × 5mm QFN or SSOP Packages

APPLICATIONS

- High Power Battery Charger Systems
- High Performance Portable Instruments
- Industrial Battery Equipped Devices
- Notebook/Subnotebook Computers

DESCRIPTION

The LTC®4000 is a high voltage, high performance controller that converts many externally compensated DC/DC power supplies into full-featured battery chargers.

Features of the LTC4000's battery charger include: accurate ($\pm 0.25\%$) programmable float voltage, selectable timer or current termination, temperature qualified charging using an NTC thermistor, automatic recharge, C/10 trickle charge for deeply discharged cells, bad battery detection and status indicator outputs. The battery charger also includes precision current sensing that allows lower sense voltages for high current applications.

The LTC4000 supports intelligent PowerPath control. An external PFET provides low loss reverse current protection. Another external PFET provides low loss charging or discharging of the battery. This second PFET also facilitates an instant-on feature that provides immediate downstream system power even when connected to a heavily discharged or short faulted battery.

The LTC4000 is available in a low profile 28-lead 4mm × 5mm QFN and SSOP packages.

LT, LT, LTC, LTM, Linear Technology and the Linear logo are registered trademarks and PowerPath is a trademark of Linear Technology Corporation. All other trademarks are the property of their respective owners.

TYPICAL APPLICATION

48V to 10.8V at 10A Buck Converter Charger for Three LiFePO₄ Cells

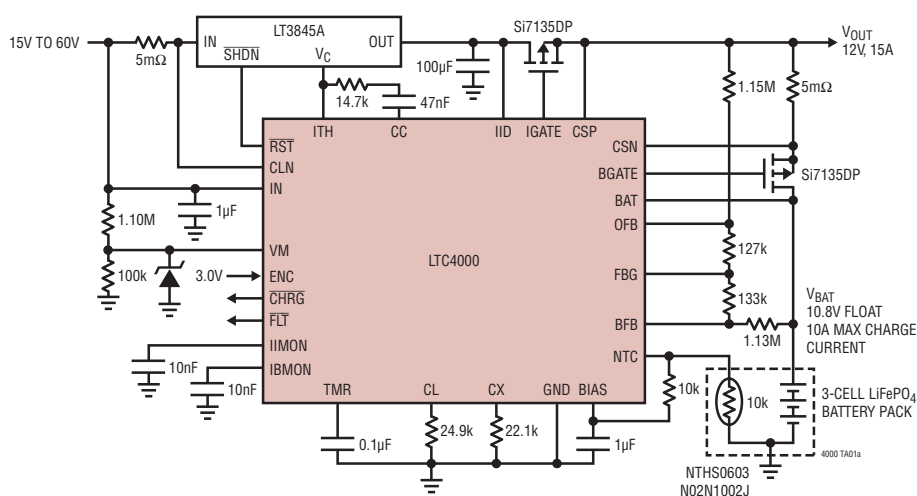

Charge Current and V_{OUT} Profile vs V_{BAT} During a Charge Cycle

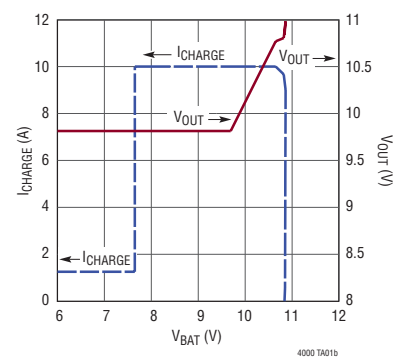

ABSOLUTE MAXIMUM RATINGS

(Note 1)

IN, CLN, IID, CSP, CSN, BAT -0.3V to 62V
 IN-CLN, CSP-CSN -1V to 1V
 OFB, BFB, FBG -0.3V to 62V
 FBG -1mA to 2mA
 IGATE Max (V_{IID} , V_{CSP}) - 10V to Max (V_{IID} , V_{CSP})
 BGATE Max (V_{BAT} , V_{CSN}) - 10V to Max (V_{BAT} , V_{CSN})
 ENC, CX, NTC, VM -0.3V to V_{BIAS}
 IL, CL, TMR, IIMON, CC -0.3V to V_{BIAS}

BIAS -0.3V to Min (6V, V_{IN})
 IBMON -0.3V to Min (V_{BIAS} , V_{CSP})
 ITH -0.3V to 6V
 \overline{CHRG} , \overline{FLT} , \overline{RST} -0.3V to 62V
 \overline{CHRG} , \overline{FLT} , \overline{RST} -1mA to 2mA
 Operating Junction Temperature Range
 (Note 2) 125°C
 Storage Temperature Range -65°C to 150°C

PIN CONFIGURATION

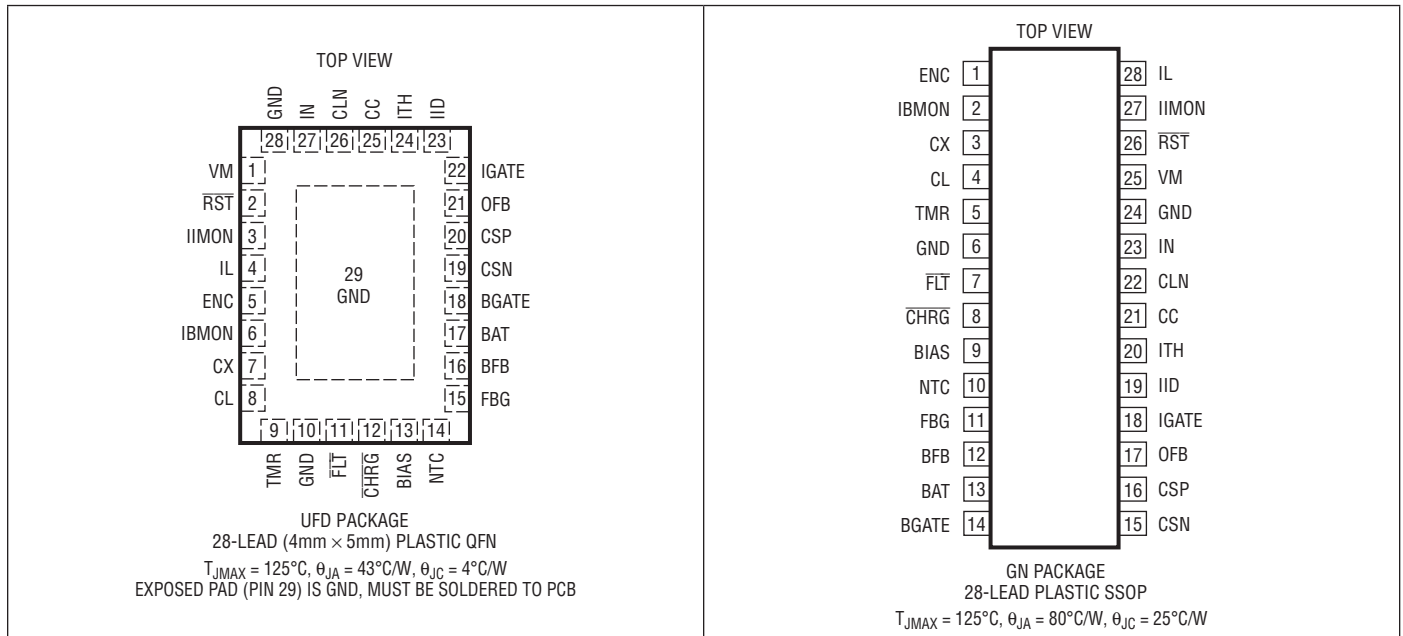

ORDER INFORMATION

LEAD FREE FINISH	TAPE AND REEL	PART MARKING*	PACKAGE DESCRIPTION	TEMPERATURE RANGE
LTC4000EUFDPBFB	LTC4000EUFDPBFB	4000	28-Lead (4mm × 5mm) Plastic QFN	-40°C to 125°C
LTC4000IUFDPBFB	LTC4000IUFDPBFB	4000	28-Lead (4mm × 5mm) Plastic QFN	-40°C to 125°C
LTC4000EGNPBFB	LTC4000EGNPBFB	LTC4000GN	28-Lead Plastic SSOP	-40°C to 125°C
LTC4000IGNPBFB	LTC4000IGNPBFB	LTC4000GN	28-Lead Plastic SSOP	-40°C to 125°C

Consult LTC Marketing for parts specified with wider operating temperature ranges. *The temperature grade is identified by a label on the shipping container. Consult LTC Marketing for information on non-standard lead based finish parts.

For more information on lead free part marking, go to: <http://www.linear.com/leadfree/>
 For more information on tape and reel specifications, go to: <http://www.linear.com/tapeandree/>

ELECTRICAL CHARACTERISTICS

The ● denotes the specifications which apply over the full operating junction temperature range, otherwise specifications are at $T_A = 25^\circ\text{C}$. $V_{IN} = V_{CLN} = 3\text{V}$ to 60V unless otherwise noted (Notes 2, 3).

SYMBOL	PARAMETER	CONDITIONS		MIN	TYP	MAX	UNITS
V_{IN}	Input Supply Operating Range		●	3		60	V
I_{IN}	Input Quiescent Operating Current				0.4		mA
I_{BAT}	Battery Pin Operating Current	$V_{IN} \geq 3\text{V}$, $V_{CSN} = V_{CSP} \geq V_{BAT}$	●		50	100	μA
	Battery Only Quiescent Current	$V_{IN} = 0\text{V}$, $V_{CSN} = V_{CSP} \leq V_{BAT}$	●		10	20	μA
Shutdown							
	ENC Input Voltage Low		●			0.4	V
	ENC Input Voltage High		●	1.5			V
	ENC Pull-Up Current	$V_{ENC} = 0\text{V}$		-4	-2	-0.5	μA
	ENC Open Circuit Voltage	$V_{ENC} = \text{Open}$	●	1.5	2.5		V
Voltage Regulation							
V_{BFB_REG}	Battery Feedback Voltage		●	1.133 1.120	1.136 1.136	1.139 1.147	V V
	BFB Input Current	$V_{BFB} = 1.2\text{V}$			± 0.1		μA
V_{OFB_REG}	Output Feedback Voltage		●	1.176	1.193	1.204	V
	OFB Input Current	$V_{OFB} = 1.2\text{V}$			± 0.1		μA
R_{FBG}	Ground Return Feedback Resistance		●		100	400	Ω
$V_{RECHRG(RISE)}$	Rising Recharge Battery Threshold Voltage	% of V_{BFB_REG}	●	96.9	97.6	98.3	%
$V_{RECHRG(HYS)}$	Recharge Battery Threshold Voltage Hysteresis	% of V_{BFB_REG}			0.5		%
$V_{OUT(INST_ON)}$	Instant-On Battery Voltage Threshold	% of V_{BFB_REG}	●	82	86	90	%
V_{LOBAT}	Falling Low Battery Threshold Voltage	% of V_{BFB_REG}	●	65	68	71	%
$V_{LOBAT(HYS)}$	Low Battery Threshold Voltage Hysteresis	% of V_{BFB_REG}			3		%
Current Regulation							
	Ratio of Monitored-Current Voltage to Sense Voltage	$V_{IN,CLN} \leq 50\text{mV}$, $V_{IIMON}/V_{IN,CLN}$ $V_{CSP,CSN} \leq 50\text{mV}$, $V_{IBMON}/V_{CSP,CSN}$	●	18.5	20	21	V/V
V_{OS}	Sense Voltage Offset	$V_{CSP,CSN} \leq 50\text{mV}$, $V_{CSP} = 60\text{V}$ or $V_{IN,CLN} \leq 50\text{mV}$, $V_{IN} = 60\text{V}$ (Note 4)		-300		300	μV
	CLN, CSP, CSN Common Mode Range	(Note 4)	●	3		60	V
	CLN Pin Current				± 1		μA
	CSP Pin Current	$V_{IGATE} = \text{Open}$, $V_{IID} = 0\text{V}$			90		μA
	CSN Pin Current	$V_{BGATE} = \text{Open}$, $V_{BAT} = 0\text{V}$			45		μA
I_{IL}	Pull-Up Current for the Input Current Limit Programming Pin		●	-55	-50	-45	μA
I_{CL}	Pull-Up Current for the Charge Current Limit Programming Pin		●	-55	-50	-45	μA
I_{CL_TRKL}	Pull-Up Current for the Charge Current Limit Programming Pin in Trickle Charge Mode	$V_{BFB} < V_{LOBAT}$	●	-5.5	-5.0	-4.5	μA
	Input Current Monitor Resistance to GND			40	90	140	$\text{k}\Omega$
	Charge Current Monitor Resistance to GND			40	90	140	$\text{k}\Omega$
	A4, A5 Error Amp Offset for the Current Loops (See Figure 1)	$V_{CL} = 0.8\text{V}$, $V_{IL} = 0.8\text{V}$	●	-10	0	10	mV
	Maximum Programmable Current Limit Voltage Range		●	0.985	1.0	1.015	V

ELECTRICAL CHARACTERISTICS

The ● denotes the specifications which apply over the full operating junction temperature range, otherwise specifications are at $T_A = 25^\circ\text{C}$. $V_{IN} = V_{CLN} = 3\text{V}$ to 60V unless otherwise noted (Notes 2, 3).

SYMBOL	PARAMETER	CONDITIONS		MIN	TYP	MAX	UNITS
Charge Termination							
	CX Pin Pull-Up Current	$V_{CX} = 0.1\text{V}$	●	-5.5	-5.0	-4.5	μA
$V_{CX,IBMON(OS)}$	CX Comparator Offset Voltage, IBMON Falling	$V_{CX} = 0.1\text{V}$	●	0.5	10	25	mV
$V_{CX,IBMON(HYS)}$	CX Comparator Hysteresis Voltage				5		mV
	TMR Pull-Up Current	$V_{TMR} = 0\text{V}$			-5.0		μA
	TMR Pull-Down Current	$V_{TMR} = 2\text{V}$			5.0		μA
	TMR Pin Frequency	$C_{TMR} = 0.01\mu\text{F}$		400	500	600	Hz
	TMR Threshold for CX Termination		●		2.1	2.5	V
t_T	Charge Termination Time	$C_{TMR} = 0.1\mu\text{F}$	●	2.3	2.9	3.5	h
t_T/t_{BB}	Ratio of Charge Terminate Time to Bad Battery Indicator Time	$C_{TMR} = 0.1\mu\text{F}$	●	3.95	4	4.05	h/h
$V_{NTC(COLD)}$	NTC Cold Threshold	V_{NTC} Rising, % of V_{BIAS}	●	73	75	77	%
$V_{NTC(HOT)}$	NTC Hot Threshold	V_{NTC} Falling, % of V_{BIAS}	●	33	35	37	%
$V_{NTC(HYS)}$	NTC Thresholds Hysteresis	% of V_{BIAS}			5		%
$V_{NTC(OPEN)}$	NTC Open Circuit Voltage	% of V_{BIAS}	●	45	50	55	%
$R_{NTC(OPEN)}$	NTC Open Circuit Input Resistance				300		$\text{k}\Omega$
Voltage Monitoring and Open Drain Status Pins							
$V_{VM(TH)}$	VM Input Falling Threshold		●	1.176	1.193	1.204	V
$V_{VM(HYS)}$	VM Input Hysteresis				40		mV
	VM Input Current	$V_{VM} = 1.2\text{V}$			± 0.1		μA
$I_{RST,CHRG,FLT(LKG)}$	Open Drain Status Pins Leakage Current	$V_{PIN} = 60\text{V}$			± 1		μA
$V_{RST,CHRG,FLT(VOL)}$	Open Drain Status Pins Voltage Output Low	$I_{PIN} = 1\text{mA}$	●			0.4	V
Input PowerPath Control							
	Input PowerPath Forward Regulation Voltage	$V_{IID,CSP}, 3\text{V} \leq V_{CSP} \leq 60\text{V}$	●	0.1	8	20	mV
	Input PowerPath Fast Reverse Turn-Off Threshold Voltage	$V_{IID,CSP}, 3\text{V} \leq V_{CSP} \leq 60\text{V}$, $V_{IGATE} = V_{CSP} - 2.5\text{V}$, $\Delta I_{IGATE}/\Delta V_{IID,CSP} \geq 100\mu\text{A/mV}$	●	-90	-50	-20	mV
	Input PowerPath Fast Forward Turn-On Threshold Voltage	$V_{IID,CSP}, 3\text{V} \leq V_{CSP} \leq 60\text{V}$, $V_{IGATE} = V_{IID} - 1.5\text{V}$, $\Delta I_{IGATE}/\Delta V_{IID,CSP} \geq 100\mu\text{A/mV}$	●	40	80	130	mV
	Input Gate Turn-Off Current	$V_{IID} = V_{CSP}, V_{IGATE} = V_{CSP} - 1.5\text{V}$			-0.3		μA
	Input Gate Turn-On Current	$V_{CSP} = V_{IID} - 20\text{mV}$, $V_{IGATE} = V_{IID} - 1.5\text{V}$			0.3		μA
$I_{IGATE(FASTOFF)}$	Input Gate Fast Turn-Off Current	$V_{CSP} = V_{IID} + 0.1\text{V}$, $V_{IGATE} = V_{CSP} - 3\text{V}$			-0.5		mA
$I_{IGATE(FASTON)}$	Input Gate Fast Turn-On Current	$V_{CSP} = V_{IID} - 0.2\text{V}$, $V_{IGATE} = V_{IID} - 1.5\text{V}$			0.7		mA
$V_{IGATE(ON)}$	Input Gate Clamp Voltage	$I_{IGATE} = 2\mu\text{A}, V_{IID} = 12\text{V}$ to 60V , $V_{CSP} = V_{IID} - 0.5\text{V}$, Measure $V_{IID} - V_{IGATE}$	●		13	15	V
	Input Gate Off Voltage	$I_{IGATE} = -2\mu\text{A}, V_{IID} = 3\text{V}$ to 59.9V , $V_{CSP} = V_{IID} + 0.5\text{V}$, Measure $V_{CSP} - V_{IGATE}$	●		0.45	0.7	V

ELECTRICAL CHARACTERISTICS

The ● denotes the specifications which apply over the full operating junction temperature range, otherwise specifications are at $T_A = 25^\circ\text{C}$. $V_{IN} = V_{CLN} = 3\text{V}$ to 60V unless otherwise noted (Notes 2, 3).

SYMBOL	PARAMETER	CONDITIONS		MIN	TYP	MAX	UNITS
Battery PowerPath Control							
	Battery Discharge PowerPath Forward Regulation Voltage	$V_{\text{BAT,CSN}}, 2.8\text{V} \leq V_{\text{BAT}} \leq 60\text{V}$	●	0.1	8	20	mV
	Battery PowerPath Fast Reverse Turn-Off Threshold Voltage	$V_{\text{BAT,CSN}}, 2.8\text{V} \leq V_{\text{BAT}} \leq 60\text{V}$, Not Charging, $V_{\text{BGATE}} = V_{\text{CSN}} - 2.5\text{V}$, $\Delta I_{\text{BGATE}}/\Delta V_{\text{BAT,CSN}} \geq 100\mu\text{A/mV}$	●	-90	-50	-20	mV
	Battery PowerPath Fast Forward Turn-On Threshold Voltage	$V_{\text{BAT,CSN}}, 2.8\text{V} \leq V_{\text{CSN}} \leq 60\text{V}$, $V_{\text{BGATE}} = V_{\text{BAT}} - 1.5\text{V}$, $\Delta I_{\text{BGATE}}/\Delta V_{\text{BAT,CSN}} \geq 100\mu\text{A/mV}$	●	40	80	130	mV
	Battery Gate Turn-Off Current	$V_{\text{BGATE}} = V_{\text{CSN}} - 1.5\text{V}$, $V_{\text{CSN}} \geq V_{\text{BAT}}$, $V_{\text{OFB}} < V_{\text{OUT(INST_ON)}}$ and Charging in Progress, or $V_{\text{CSN}} = V_{\text{BAT}}$ and Not Charging			-0.3		μA
	Battery Gate Turn-On Current	$V_{\text{BGATE}} = V_{\text{BAT}} - 1.5\text{V}$, $V_{\text{CSN}} \geq V_{\text{BAT}}$, $V_{\text{OFB}} > V_{\text{OUT(INST_ON)}}$ and Charging in Progress, or $V_{\text{CSN}} = V_{\text{BAT}} - 20\text{mV}$			0.3		μA
$I_{\text{BGATE(FASTOFF)}}$	Battery Gate Fast Turn-Off Current	$V_{\text{CSN}} = V_{\text{BAT}} + 0.1\text{V}$ and Not Charging, $V_{\text{BGATE}} = V_{\text{CSN}} - 3\text{V}$			-0.5		mA
$I_{\text{BGATE(FASTON)}}$	Battery Gate Fast Turn-On Current	$V_{\text{CSN}} = V_{\text{BAT}} - 0.2\text{V}$, $V_{\text{BGATE}} = V_{\text{BAT}} - 1.5\text{V}$			0.7		mA
$V_{\text{BGATE(ON)}}$	Battery Gate Clamp Voltage	$I_{\text{BGATE}} = 2\mu\text{A}$, $V_{\text{BAT}} = 12\text{V}$ to 60V , $V_{\text{CSN}} = V_{\text{BAT}} - 0.5\text{V}$, Measure $V_{\text{BAT}} - V_{\text{BGATE}}$	●		13	15	V
	Battery Gate Off Voltage	$I_{\text{BGATE}} = -2\mu\text{A}$, $V_{\text{BAT}} = 2.8\text{V}$ to 60V , $V_{\text{CSN}} = V_{\text{BAT}} + 0.5\text{V}$ and not Charging, Measure $V_{\text{CSN}} - V_{\text{BGATE}}$	●		0.45	0.7	V
BIAS Regulator Output and Control Pins							
V_{BIAS}	BIAS Output Voltage	No Load	●	2.4	2.9	3.5	V
ΔV_{BIAS}	BIAS Output Voltage Load Regulation	$I_{\text{BIAS}} = -0.5\text{mA}$			-0.5	-10	%
	BIAS Output Short-Circuit Current	$V_{\text{BIAS}} = 0\text{V}$			-12		mA
	Transconductance of Error Amp	$\text{CC} = 1\text{V}$			0.5		mA/V
	Open Loop DC Voltage Gain of Error Amp	$\text{CC} = \text{Open}$			80		dB
$I_{\text{ITH(PULL_UP)}}$	Pull-Up Current on the ITH Pin	$V_{\text{ITH}} = 0\text{V}$, $\text{CC} = 0\text{V}$		-6	-5	-4	μA
$I_{\text{ITH(PULL_DOWN)}}$	Pull-Down Current on the ITH Pin	$V_{\text{ITH}} = 0.4\text{V}$, $\text{CC} = \text{Open}$	●	0.5	1		mA
	Open Loop DC Voltage Gain of ITH Driver	$\text{ITH} = \text{Open}$			60		dB

Note 1: Stresses beyond those listed under Absolute Maximum Ratings may cause permanent damage to the device. Exposure to any Absolute Maximum Rating condition for extended periods may affect device reliability and lifetime.

Note 2: The LTC4000 is tested under conditions such that $T_J \approx T_A$. The LTC4000E is guaranteed to meet specifications from 0°C to 85°C junction temperature. Specifications over the -40°C to 125°C operating junction temperature range are assured by design, characterization and correlation with statistical process controls. The LTC4000I is guaranteed over the full -40°C to 125°C operating junction temperature range. Note that the maximum ambient temperature consistent with these specifications is

determined by specific operating conditions in conjunction with board layout, the rated package thermal impedance and other environmental factors. The junction temperature (T_J , in $^\circ\text{C}$) is calculated from the ambient temperature (T_A , in $^\circ\text{C}$) and power dissipation (P_D , in Watts) according to the following formula:

$$T_J = T_A + (P_D \cdot \theta_{JA}), \text{ where } \theta_{JA} \text{ (in } ^\circ\text{C/W) is the package thermal impedance.}$$

Note 3: All currents into pins are positive; all voltages are referenced to GND unless otherwise noted.

Note 4: These parameters are guaranteed by design and are not 100% tested.

TYPICAL PERFORMANCE CHARACTERISTICS

Input Quiescent Current and Battery Quiescent Current Over Temperature

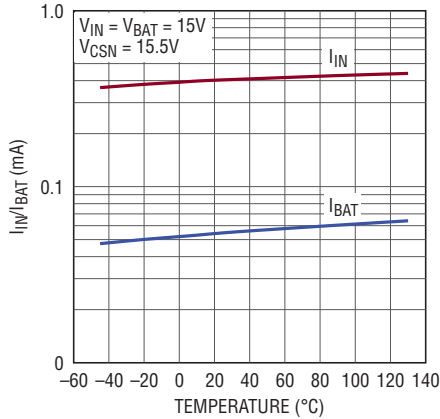

Battery Only Quiescent Current Over Temperature

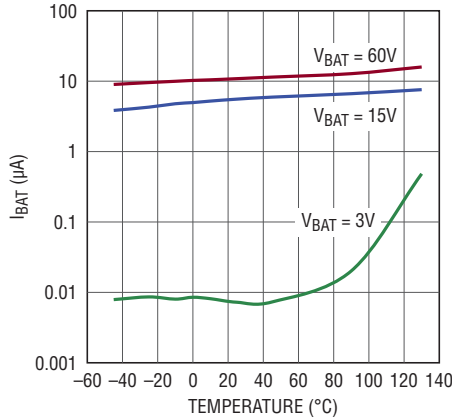

Battery Float Voltage Feedback, Output Voltage Regulation Feedback and VM Falling Threshold Over Temperature

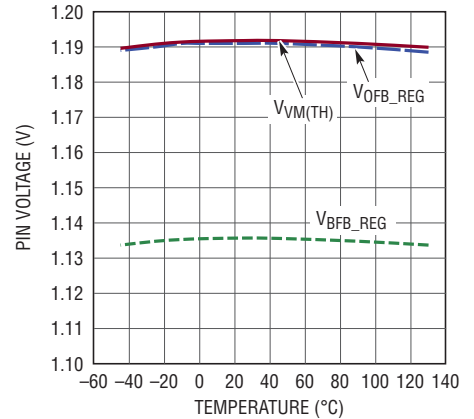

Battery Thresholds: Rising Recharge, Instant-On Regulation and Falling Low Battery As a Percentage of Battery Float Feedback Over Temperature

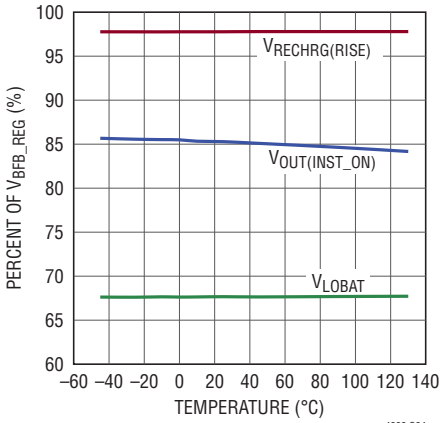

I_L and C_L Pull-Up Current Over Temperature

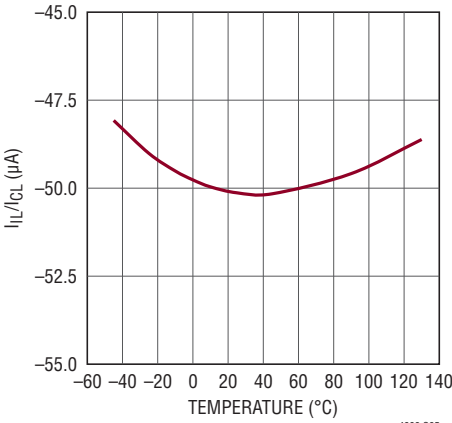

Maximum Programmable Current Limit Voltage Over Temperature

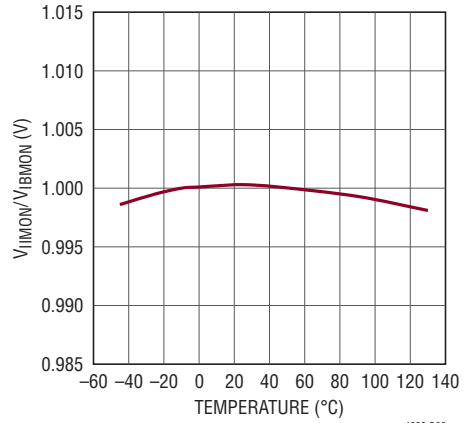

Current Sense Offset Voltage Over Temperature

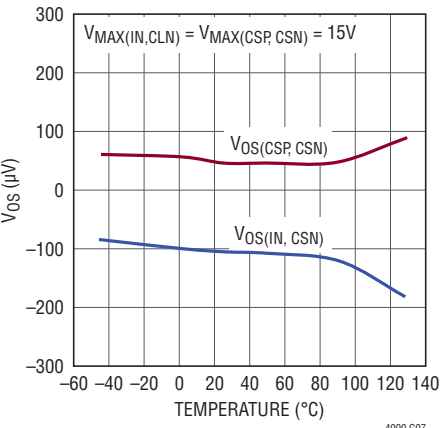

Current Sense Offset Voltage Over Common Mode Voltage Range

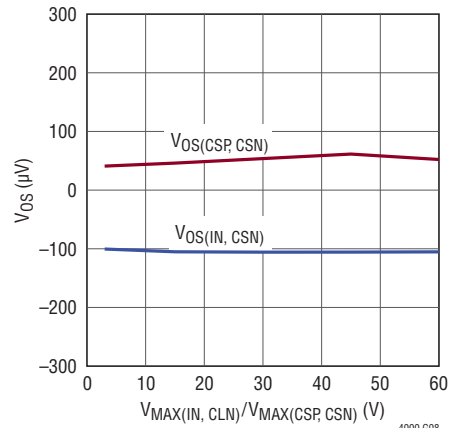

CX Comparator Offset Voltage with V_IBMON Falling Over Temperature

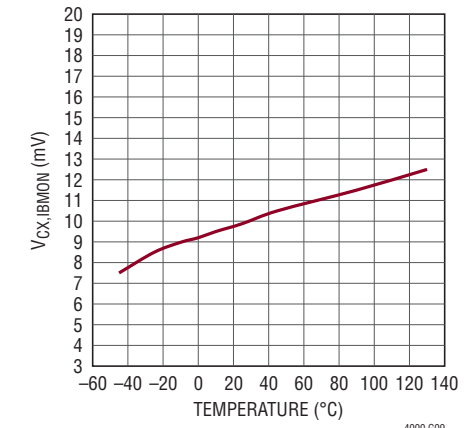

TYPICAL PERFORMANCE CHARACTERISTICS

Charge Termination Time with 0.1 μ F Timer Capacitor Over Temperature

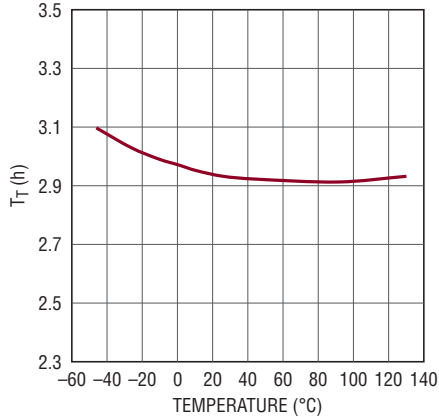

NTC Thresholds Over Temperature

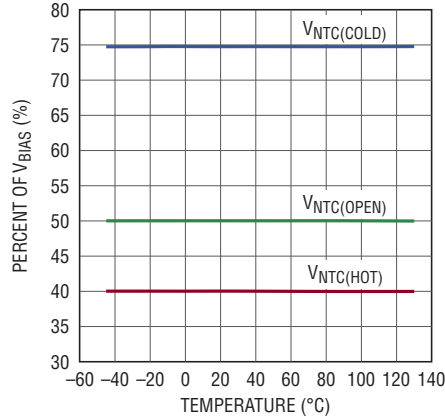

PowerPath Forward Voltage Regulation Over Temperature

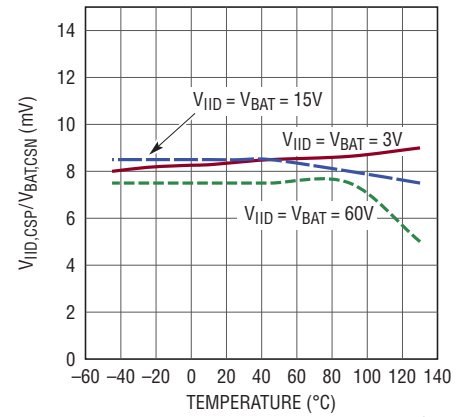

PowerPath Fast Off, Fast On and Forward Regulation Over Temperature

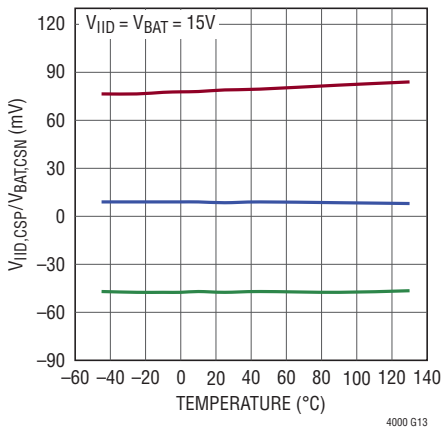

PowerPath Turn-On Gate Clamp Voltage Over Temperature

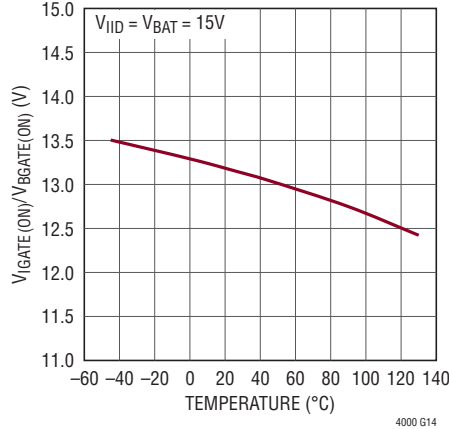

PowerPath Turn-Off Gate Voltage Over Temperature

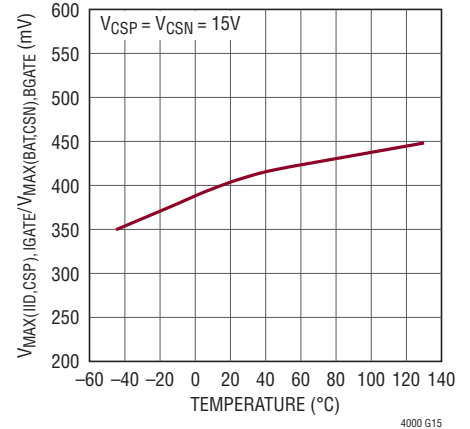

BIAS Voltage at 0.5mA Load Over Temperature

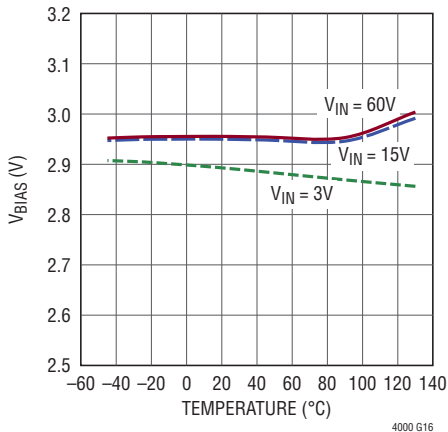

I_TH Pull-Down Current Over Temperature

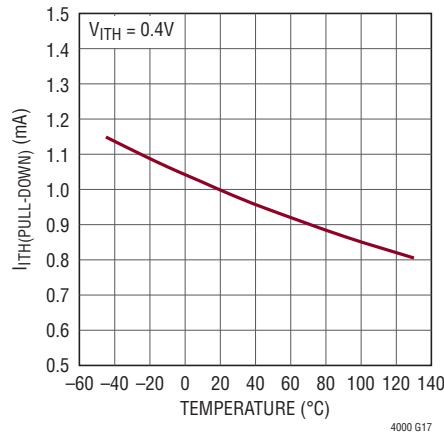

I_TH Pull-Down Current vs V_TH

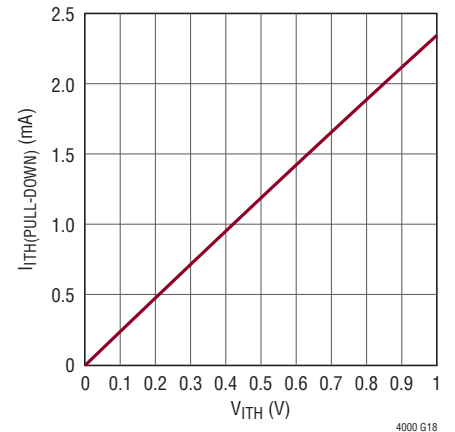

PIN FUNCTIONS (QFN/SSOP)

VM (Pin 1/Pin 25): Voltage Monitor Input. High impedance input to an accurate comparator with a 1.193V threshold (typical). This pin controls the state of the $\overline{\text{RST}}$ output pin. Connect a resistor divider (R_{VM1} , R_{VM2}) between the monitored voltage and GND, with the center tap point connected to this pin. The falling threshold of the monitored voltage is calculated as follows:

$$V_{\text{VM_RST}} = \frac{R_{\text{VM1}} + R_{\text{VM2}}}{R_{\text{VM2}}} \cdot 1.193\text{V}$$

where R_{VM2} is the bottom resistor between the VM pin and GND. Tie to the BIAS pin if voltage monitoring function is not used.

$\overline{\text{RST}}$ (Pin 2/Pin 26): High Voltage Open Drain Reset Output. When the voltage at the VM pin is below 1.193V, this status pin is pulled low. When driven low, this pin can disable a DC/DC converter when connected to the converter's enable pin. This pin can also drive an LED to provide a visual status indicator of a monitored voltage. Short this pin to GND when not used.

IIMON (Pin 3/Pin 27): Input Current Monitor. The voltage on this pin is 20 times (typical) the sense voltage ($V_{\text{IN,CLN}}$) across the input current sense resistor (R_{IS}), therefore providing a voltage proportional to the input current. Connect an appropriate capacitor to this pin to obtain a voltage representation of the time-average input current. Short this pin to GND to disable input current limit feature.

IL (Pin 4/Pin 28): Input Current Limit Programming. Connect the input current programming resistor (R_{IL}) to this pin. This pin sources 50 μA of current. The regulation loop compares the voltage on this pin with the input current monitor voltage (V_{IIMON}), and drives the ITH pin accordingly to ensure that the programmed input current limit is not exceeded. The input current limit is determined using the following formula:

$$I_{\text{ILIM}} = 2.5\mu\text{A} \cdot \left(\frac{R_{\text{IL}}}{R_{\text{IS}}} \right)$$

where R_{IS} is the sense resistor connected to the IN and the CLN pins. Leave the pin open for the maximum input current limit of 50mV/ R_{IS} .

ENC (Pin 5/Pin 1): Enable Charging Pin. High impedance digital input pin. Pull this pin above 1.5V to enable charging and below 0.5V to disable charging. Leaving this pin open causes the internal 2 μA pull-up current to pull the pin to 2.5V (typical).

IBMON (Pin 6/Pin 2): Battery Charge Current Monitor. The voltage on this pin is 20 times (typical) the sense voltage ($V_{\text{CSP,CSN}}$) across the battery current sense resistor (R_{CS}), therefore providing a voltage proportional to the battery charge current. Connect an appropriate capacitor to this pin to obtain a voltage representation of the time-average battery charge current. Short this pin to GND to disable charge current limit feature.

CX (Pin 7/Pin 3): Charge Current Termination Programming. Connect the charge current termination programming resistor (R_{CX}) to this pin. This pin is a high impedance input to a comparator and sources 5 μA of current. When the voltage on this pin is greater than the charge current monitor voltage (V_{IBMON}), the $\overline{\text{CHRG}}$ pin turns high impedance indicating that the CX threshold is reached. When this occurs, the charge current is immediately terminated if the TMR pin is shorted to the BIAS pin, otherwise charging continues until the charge termination timer expires. The charge current termination value is determined using the following formula:

$$I_{\text{C/X}} = \frac{(0.25\mu\text{A} \cdot R_{\text{CX}}) - 0.5\text{mV}}{R_{\text{CS}}}$$

Where R_{CS} is the sense resistor connected to the CSP and the CSN pins. Note that if $R_{\text{CX}} = R_{\text{CL}} \leq 19.1\text{k}\Omega$, where R_{CL} is the charge current programming resistor, then the charge current termination value is one tenth the full charge current, more familiarly known as C/10. Short this pin to GND to disable CX termination.

CL (Pin 8/Pin 4): Charge Current Limit Programming. Connect the charge current programming resistor (R_{CL}) to this pin. This pin sources 50 μA of current. The regulation loop compares the voltage on this pin with the charge current monitor voltage (V_{IBMON}), and drives the ITH pin accordingly to ensure that the programmed charge current limit

PIN FUNCTIONS (QFN/SSOP)

is not exceeded. The charge current limit is determined using the following formula:

$$I_{CLIM} = 2.5\mu A \cdot \left(\frac{R_{CL}}{R_{CS}} \right)$$

Where R_{CS} is the sense resistor connected to the CSP and the CSN pins. Leave the pin open for the maximum charge current limit of $50mV/R_{CS}$.

TMR (Pin 9/Pin 5): Charge Timer. Attach 1nF of external capacitance (C_{TMR}) to GND for each 104 seconds of charge termination time and 26 seconds of bad battery indicator time. Short to GND to prevent bad battery indicator time and charge termination time from expiring – allowing a continuous trickle charge and top off float voltage regulation charge. Short to BIAS to disable bad battery detect and enable C/X charging termination.

GND (Pins 10, 28, 29/Pins 6, 24): Device Ground Pins. Connect the ground pins to a suitable PCB copper ground plane for proper electrical operation. The QFN package exposed pad must be soldered to PCB ground for rated thermal performance.

FLT, CHR \bar{G} (Pin 11, Pin 12/Pin 7, Pin 8): Charge Status Indicator Pins. These pins are high voltage open drain pull down pins. The \overline{FLT} pin pulls down when there is an under or over temperature condition during charging or when the voltage on the BFB pin stays below the low battery threshold during charging for a period longer than the bad battery indicator time. The $\overline{CHR\bar{G}}$ pin pulls down during a charging cycle. Please refer to the application information section for details on specific modes indicated by the combination of the states of these two pins. Pull up each of these pins with an LED in series with a resistor to a voltage source to provide a visual status indicator. Short these pins to GND when not used.

BIAS (Pin 13/Pin 9): 2.9V Regulator Output. Connect a capacitor of at least 470nF to bypass this 2.9V regulated voltage output. Use this pin to bias the resistor divider to set up the voltage at the NTC pin.

NTC (Pin 14/Pin 10): Thermistor Input. Connect a thermistor from NTC to GND, and a corresponding resistor from BIAS to NTC. The voltage level on this pin determines

if the battery temperature is safe for charging. The charge current and charge timer are suspended if the thermistor indicates a temperature that is unsafe for charging. Once the temperature returns to the safe region, charging resumes. Leave the pin open or connected to a capacitor to disable the temperature qualified charging function.

FBG (Pin 15/Pin 11): Feedback Ground Pin. This is the ground return pin for the resistor dividers connected to the BFB and OFB pins. As soon as the voltage at IN is valid (>3V typical), this pin has a 100 Ω resistance to GND. When the voltage at IN is not valid, this pin is disconnected from GND to ensure that the resistor dividers connected to the BFB and OFB pins do not continue to drain the battery when the battery is the only available power source.

BFB (Pin 16/Pin 12): Battery Feedback Voltage Pin. This pin is a high impedance input pin used to sense the battery voltage level. In regulation, the battery float voltage loop sets the voltage on this pin to 1.136V (typical). Connect this pin to the center node of a resistor divider between the BAT pin and the FBG pin to set the battery float voltage. The battery float voltage can then be obtained as follows:

$$V_{FLOAT} = \frac{R_{BFB2} + R_{BFB1}}{R_{BFB2}} \cdot 1.136V$$

BAT (Pin 17/Pin 13): Battery Pack Connection. Connect the battery to this pin. This pin is the anode of the battery ideal diode driver (the cathode is the CSN pin).

BGATE (Pin 18/Pin 14): External Battery PMOS Gate Drive Output. When not charging, the BGATE pin drives the external PMOS to behave as an ideal diode from the BAT pin (anode) to the CSN pin (cathode). This allows efficient delivery of any required additional power from the battery to the downstream system connected to the CSN pin.

When charging a heavily discharged battery, the BGATE pin is regulated to set the output feedback voltage (OFB pin) to 86% of the battery float voltage (0.974V typical). This allows the instant-on feature, providing an immediate valid voltage level at the output when the LTC4000 is charging a heavily discharged battery. Once the voltage on the OFB pin is above the 0.974V typical value, then the BGATE pin is driven low to ensure an efficient charging path from the CSN pin to the BAT pin.

PIN FUNCTIONS (QFN/SSOP)

CSN (Pin 19/Pin 15): Charge Current Sense Negative Input and Battery Ideal Diode Cathode. Connect a sense resistor between this pin and the CSP pin. The LTC4000 senses the voltage across this sense resistor and regulates it to a voltage equal to 1/20th (typical) of the voltage set at the CL pin. The maximum regulated sense voltage is 50mV. The CSN pin is also the cathode input of the battery ideal diode driver (the anode input is the BAT pin). Tie this pin to the CSP pin if no charge current limit is desired. Refer to the Applications Information section for complete details.

CSP (Pin 20/Pin 16): Charge Current Sense Positive Input and Input Ideal Diode Cathode. Connect a sense resistor between this pin and the CSN pin for charge current sensing and regulation. This input should be tied to CSN to disable the charge current regulation function. This pin is also the cathode of the input ideal diode driver (the anode is the IID pin).

OFB (Pin 21/Pin 17): Output Feedback Voltage Pin. This pin is a high impedance input pin used to sense the output voltage level. In regulation, the output voltage loop sets the voltage on this feedback pin to 1.193V. Connect this pin to the center node of a resistor divider between the CSP pin and the FBG pin to set the output voltage when battery charging is terminated and all the output load current is provided from the input. The output voltage can then be obtained as follows:

$$V_{OUT} = \frac{R_{OFB2} + R_{OFB1}}{R_{OFB2}} \cdot 1.193V$$

When charging a heavily discharged battery (such that $V_{OFB} < V_{OUT(INST_ON)}$), the battery PowerPath PMOS connected to BGATE is regulated to set the voltage on this feedback pin to 0.974V (approximately 86% of the battery float voltage). The instant-on output voltage is then as follows:

$$V_{OUT(INST_ON)} = \frac{R_{OFB2} + R_{OFB1}}{R_{OFB2}} \cdot 0.974V$$

IGATE (Pin 22/Pin 18): Input PMOS Gate Drive Output. The IGATE pin drives the external PMOS to behave as an ideal diode from the IID pin (anode) to the CSP pin (cathode)

when the voltage at the IN pin is within its operating range (3V to 60V). To ensure that the input PMOS is turned off when the IN pin voltage is not within its operating range, connect a 10M resistor from this pin to the CSP pin.

IID (Pin 23/Pin 19): Input Ideal Diode Anode. This pin is the anode of the input ideal diode driver (the cathode is the CSP pin).

ITH (Pin 24/Pin 20): High Impedance Control Voltage Pin. When any of the regulation loops (input current, charge current, battery float voltage or the output voltage) indicate that its limit is reached, the ITH pin will sink current (up to 1mA) to regulate that particular loop at the limit. In many applications, this ITH pin is connected to the control/compensation node of a DC/DC converter. Without any external pull-up, the operating voltage range on this pin is GND to 2.5V. With an external pull-up, the voltage on this pin can be pulled up to 6V. Note that the impedance connected to this pin affects the overall loop gain. For details, refer to the Applications Information section.

CC (Pin 25/Pin 21): Converter Compensation Pin. Connect an R-C network from this pin to the ITH pin to provide a suitable loop compensation for the converter used. Refer to the Applications Information section for discussion and procedure on choosing an appropriate R-C network for a particular DC/DC converter.

CLN (Pin 26/Pin 22): Input Current Sense Negative Input. Connect a sense resistor between this pin and the IN pin. The LTC4000 senses the voltage across this sense resistor and regulates it to a voltage equal to 1/20th (typical) of the voltage set at the IL pin. Tie this pin to the IN pin if no input current limit is desired. Refer to the Applications Information section for complete details.

IN (Pin 27/Pin 23): Input Supply Voltage: 3V to 60V. Supplies power to the internal circuitry and the BIAS pin. Connect the power source to the downstream system and the battery charger to this pin. This pin is also the positive sense pin for the input current limit. Connect a sense resistor between this pin and the CLN pin. Tie this pin to CLN if no input current limit is desired. A local 0.1µF bypass capacitor to ground is recommended on this pin.

BLOCK DIAGRAM

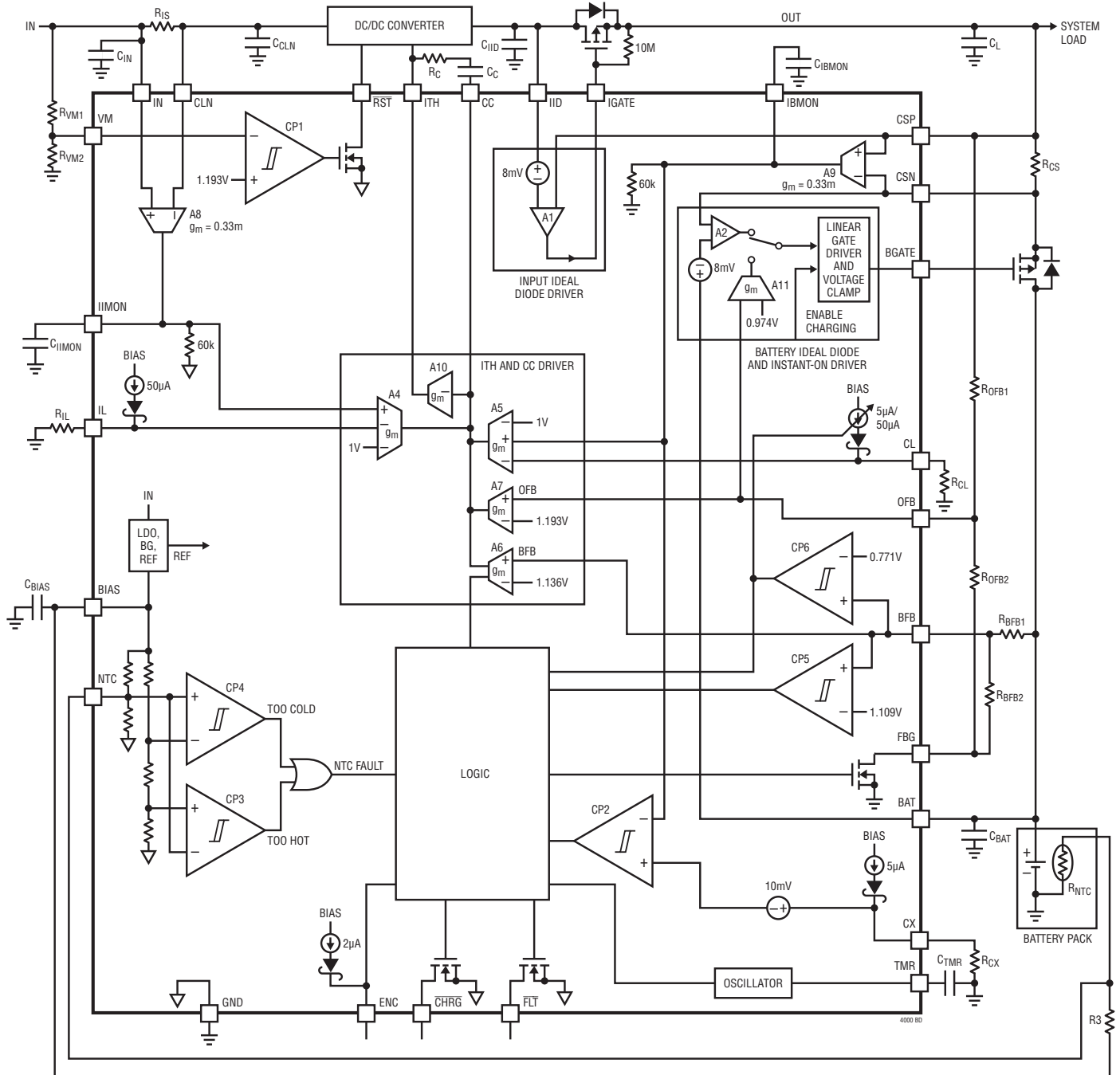

Figure 1. LTC4000 Functional Block Diagram

OPERATION

Overview

The LTC4000 is designed to simplify the conversion of any externally compensated DC/DC converter into a high performance battery charger with PowerPath control. It only requires the DC/DC converter to have a control or external-compensation pin (usually named VC or ITH) whose voltage level varies in a positive monotonic way with its output. The output variable can be either output voltage or output current. For the following discussion, refer to the Block Diagram in Figure 1.

The LTC4000 includes four different regulation loops: input current, charge current, battery float voltage and output voltage (A4-A7). Whichever loop requires the lowest voltage on the ITH pin for its regulation controls the external DC/DC converter.

The input current regulation loop ensures that the programmed input current limit (using a resistor at IL) is not exceeded at steady state. The charge current regulation loop ensures that the programmed battery charge current limit (using a resistor at CL) is not exceeded. The float voltage regulation loop ensures that the programmed battery stack voltage (using a resistor divider from BAT to FBG via BFB) is not exceeded. The output voltage regulation loop ensures that the programmed system output voltage (using a resistor divider from CSP to FBG via OFB) is not exceeded. The LTC4000 also provides monitoring pins for the input current and charge current at the IIMON and IBMON pins respectively.

The LTC4000 features an ideal diode controller at the input from the IID pin to the CSP pin and a PowerPath controller at the output from the BAT pin to the CSN pin. The output PowerPath controller behaves as an ideal diode controller when not charging. When charging, the output PowerPath controller has two modes of operation. If $V_{O_{FB}}$ is greater than $V_{OUT(INST_ON)}$, BGATE is driven low. When $V_{O_{FB}}$ is less than $V_{OUT(INST_ON)}$, a linear regulator implements the instant-on feature. This feature provides regulation of the BGATE pin so that a valid voltage level is immediately available at the output when the LTC4000 is charging an over-discharged, dead or short faulted battery.

The state of the ENC pin determines whether charging is enabled. When ENC is grounded, charging is disabled and

the battery float voltage loop is disabled. Charging is enabled when the ENC pin is left floating or pulled high ($\geq 1.5V$)

The LTC4000 offers several user configurable battery charge termination schemes. The TMR pin can be configured for either C/X termination, charge timer termination or no termination. After a particular charge cycle terminates, the LTC4000 features an automatic recharge cycle if the battery voltage drops below 97.6% of the programmed float voltage.

Trickle charge mode drops the charge current to one tenth of the normal charge current (programmed using a resistor from the CL pin to GND) when charging into an over discharged or dead battery. When trickle charging, a capacitor on the TMR pin can be used to program a time out period. When this bad battery timer expires and the battery voltage fails to charge above the low battery threshold (V_{LOBAT}), the LTC4000 will terminate charging and indicate a bad battery condition through the status pins (\overline{FLT} and \overline{CHRG}).

The LTC4000 also includes an NTC pin, which provides temperature qualified charging when connected to an NTC thermistor thermally coupled to the battery pack. To enable this feature, connect the thermistor between the NTC and the GND pins, and a corresponding resistor from the BIAS pin to the NTC pin. The LTC4000 also provides a charging status indicator through the \overline{FLT} and the \overline{CHRG} pins.

Aside from biasing the thermistor-resistor network, the BIAS pin can also be used for a convenient pull up voltage. This pin is the output of a low dropout voltage regulator that is capable of providing up to 0.5mA of current. The regulated voltage on the BIAS pin is available as soon as the IN pin is within its operating range ($\geq 3V$).

Input Ideal Diode

The input ideal diode feature provides low loss conduction and reverse blocking from the IID pin to the CSP pin. This reverse blocking prevents reverse current from the output (CSP pin) to the input (IID pin) which causes unnecessary drain on the battery and in some cases may result in unexpected DC/DC converter behavior.

The ideal diode behavior is achieved by controlling an external PMOS connected to the IID pin (drain) and the

OPERATION

CSP pin (source). The controller (A1) regulates the external PMOS by driving the gate of the PMOS device such that the voltage drop across IID and CSP is 8mV (typical). When the external PMOS ability to deliver a particular current with an 8mV drop across its source and drain is exceeded, the voltage at the gate clamps at $V_{IGATE(ON)}$ and the PMOS behaves like a fixed value resistor ($R_{DS(ON)}$).

Note that this input ideal diode function is only enabled when the voltage at the IN pin is within its operating range (3V to 60V). To ensure that the external PMOS is turned off when the voltage at the IN pin is not within its operating range, a 10M pull-up resistor between the IGATE and the CSP pin is recommended.

Input Current Regulation and Monitoring

One of the loops driving the ITH and CC pins is the input current regulation loop (Figure 2). This loop prevents the input current sensed through the input current sense resistor (R_{IS}) from exceeding the programmed input current limit.

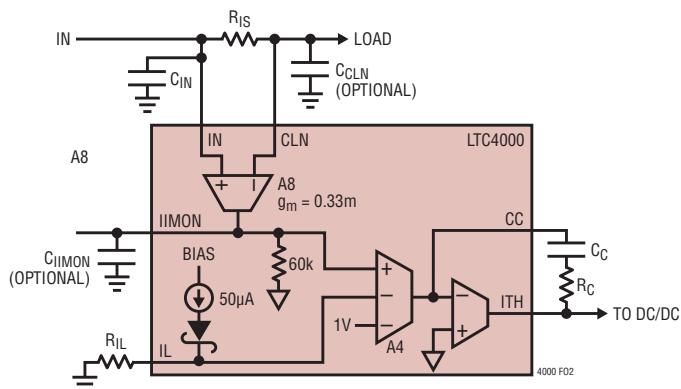

Figure 2. Input Current Regulation Loop

Battery Charger Overview

In addition to the input current regulation loop, the LTC4000 regulates charge current, battery voltage and output voltage.

When a battery charge cycle begins, the battery charger first determines if the battery is over-discharged. If the battery feedback voltage is below V_{LOBAT} , an automatic trickle charge feature uses the charge current regulation loop to set the battery charge current to 10% of the programmed full scale value. If the TMR pin is connected to a capacitor

or open, the bad battery detection timer is enabled. When this bad battery detection timer expires and the battery voltage is still below V_{LOBAT} , the battery charger automatically terminates and indicates, via the \overline{FLT} and \overline{CHRG} pins, that the battery was unresponsive to charge current.

Once the battery voltage is above V_{LOBAT} , the charge current regulation loop begins charging in full power constant-current mode. In this case, the programmed full charge current is set with a resistor on the CL pin.

Depending on available input power and external load conditions, the battery charger may not be able to charge at the full programmed rate. The external load is always prioritized over the battery charge current. The input current limit programming is always observed, and only additional power is available to charge the battery. When system loads are light, battery charge current is maximized.

Once the float voltage is achieved, the battery float voltage regulation loop takes over from the charge current regulation loop and initiates constant voltage charging. In constant voltage charging, charge current slowly declines.

Charge termination can be configured with the TMR pin in several ways. If the TMR pin is tied to the BIAS pin, C/X termination is selected. In this case, charging is terminated when constant voltage charging reduces the charge current to the C/X level programmed at the CX pin. Connecting a capacitor to the TMR pin selects the charge timer termination and a charge termination timer is started at the beginning of constant voltage charging. Charging terminates when the termination timer expires. When continuous charging at the float voltage is desired, tie the TMR pin to GND to disable termination.

Upon charge termination, the PMOS connected to BGATE behaves as an ideal diode from BAT to CSN. The diode function prevents charge current but provides current to the system load as needed. If the system load can be completely supplied from the input, the battery PMOS turns off. While terminated, if the input current limit is not in regulation, the output voltage regulation loop takes over to ensure that the output voltage at CSP remains in control. The output voltage regulation loop regulates the voltage at the CSP pin such that the output feedback voltage at the OFB pin is 1.193V.

OPERATION

If the system load requires more power than is available from the input, the battery ideal diode controller provides supplemental power from the battery. When the battery voltage discharges below 97.1% of the float voltage ($V_{BFB} < V_{RECHRG(FALL)}$), the automatic recharge feature initiates a new charge cycle.

Charge Current Regulation

The first loop involved in a normal charging cycle is the charge current regulation loop (Figure 3). As with the input current regulation loop, this loop also drives the ITH and CC pins. This loop ensures that the charge current sensed through the charge current sense resistor (R_{CS}) does not exceed the programmed full charge current.

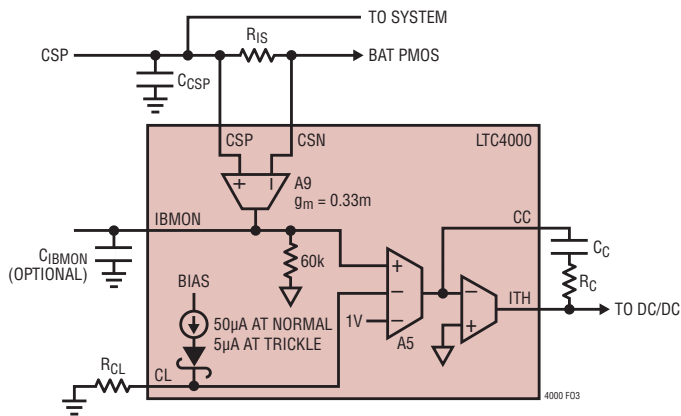

Figure 3. Charge Current Regulation Loop

Battery Voltage Regulation

Once the float voltage is reached, the battery voltage regulation loop takes over from the charge current regulation loop (Figure 4).

The float voltage level is programmed using the feedback resistor divider between the BAT pin and the FBG pin with the center node connected to the BFB pin. Note that the ground return of the resistor divider is connected to the FBG pin. The FBG pin disconnects the resistor divider load when $V_{IN} < 3V$ to ensure that the float voltage resistor divider does not consume battery current when the battery is the only available power source. For $V_{IN} \geq 3V$, the typical resistance from the FBG pin to GND is 100Ω.

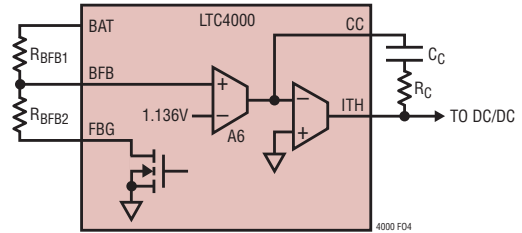

Figure 4. Battery Float Voltage Regulation Loop with FBG

Output Voltage Regulation

When charging terminates and the system load is completely supplied from the input, the PMOS connected to BGATE is turned off. In this scenario, the output voltage regulation loop takes over from the battery float voltage regulation loop (Figure 5). The output voltage regulation loop regulates the voltage at the CSP pin such that the output feedback voltage at the OFB pin is 1.193V.

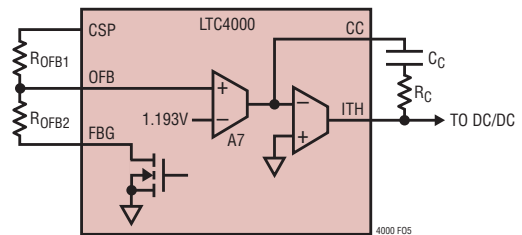

Figure 5. Output Voltage Regulation Loop with FBG

Battery Instant-On and Ideal Diode

The LTC4000 controls the external PMOS connected to the BGATE pin with a controller similar to the input ideal diode controller driving the IGATE pin. When not charging, the PMOS behaves as an ideal diode between the BAT (anode) and the CSN (cathode) pins. The controller (A2) regulates the external PMOS to achieve low loss conduction by driving the gate of the PMOS device such that the voltage drop from the BAT pin to the CSN pin is 8mV. When the ability to deliver a particular current with an 8mV drop across the PMOS source and drain is exceeded, the voltage at the gate clamps at $V_{BGATE(ON)}$ and the PMOS behaves like a fixed value resistor ($R_{DS(ON)}$).

The ideal diode behavior allows the battery to provide current to the load when the input supply is in current limit or the DC/DC converter is slow to react to an immediate load increase at the output. In addition to the ideal diode

OPERATION

behavior, BGATE also allows current to flow from the CSN pin to the BAT pin during charging.

There are two regions of operation when current is flowing from the CSN pin to the BAT pin. The first is when charging into a battery whose voltage is below the instant-on threshold ($V_{OFB} < V_{OUT(INST_ON)}$). In this region of operation, the controller regulates the voltage at the CSP pin to be approximately 86% of the final float voltage level ($V_{OUT(INST_ON)}$). This feature provides a CSP voltage significantly higher than the battery voltage when charging into a heavily discharged battery. This instant-on feature allows the LTC4000 to provide sufficient voltage at the output (CSP pin), independent of the battery voltage.

The second region of operation is when the battery feedback voltage is greater than or equal to the instant-on threshold ($V_{OUT(INST_ON)}$). In this region, the BGATE pin is driven low and clamped at $V_{BGATE(ON)}$ to allow the PMOS to turn completely on, reducing any power dissipation due to the charge current.

Battery Temperature Qualified Charging

The battery temperature is measured by placing a negative temperature coefficient (NTC) thermistor close to the battery pack. The comparators CP3 and CP4 implement the temperature detection as shown in the Block Diagram in Figure 1. The rising threshold of CP4 is set at 75% of V_{BIAS} (cold threshold) and the falling threshold of CP3 is set at 35% of V_{BIAS} (hot threshold). When the voltage at the NTC pin is above 75% of V_{BIAS} or below 35% of V_{BIAS} then the LTC4000 pauses any charge cycle in progress. When the voltage at the NTC pin returns to the range of 40% to 70% of V_{BIAS} , charging resumes.

When charging is paused, the external charging PMOS turns off and charge current drops to zero. If the LTC4000 is charging in the constant voltage mode and the charge termination timer is enabled, the timer pauses until the thermistor indicates a return to a valid temperature. If the battery charger is in the trickle charge mode and the bad battery detection timer is enabled, the bad battery timer pauses until the thermistor indicates a return to a valid temperature.

Input UVLO and Voltage Monitoring

The regulated voltage on the BIAS pin is available as soon as $V_{IN} \geq 3V$. When $V_{IN} \geq 3V$, the FBG pin is pulled low to GND with a typical resistance of 100Ω and the rest of the chip functionality is enabled.

When the IN pin is high impedance and a battery is connected to the BAT pin, the BGATE pin is pulled down with a $2\mu A$ (typical) current source to hold the battery PMOS gate voltage at $V_{BGATE(ON)}$ below V_{BAT} . This allows the battery to power the output. The total quiescent current consumed by LTC4000 from the battery when IN is not valid is typically $\leq 10\mu A$.

When the IN pin is high impedance, the input ideal diode function for the external FET connected to the IGATE pin is disabled. To ensure that this FET is completely turned off when the voltage at the IN pin is not within its operating range, connect a $10M$ pull-up resistor between the IGATE pin and the CSP pin.

Besides the internal input UVLO, the LTC4000 also provides voltage monitoring through the VM pin. The \overline{RST} pin is pulled low when the voltage on the VM pin falls below 1.193V (typical). On the other hand, when the voltage on the VM pin rises above 1.233V (typical), the \overline{RST} pin is high impedance.

One common use of this voltage monitoring feature is to ensure that the converter is turned off when the voltage at the input is below a certain level. In this case, connect the \overline{RST} pin to the DC/DC converter chip select or enable pin (see Figure 6).

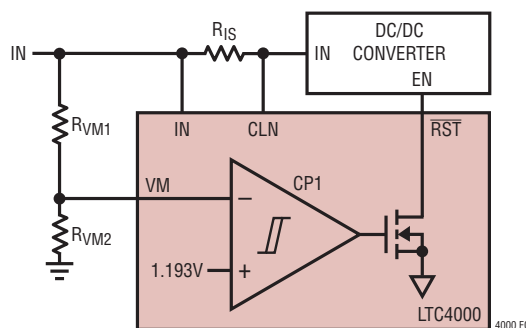

Figure 6. Input Voltage Monitoring with \overline{RST} Connected to the EN Pin of the DC/DC Converter

APPLICATIONS INFORMATION

Input Ideal Diode PMOS Selection

The input external PMOS is selected based on the expected maximum current, power dissipation and reverse voltage drop. The PMOS must be able to withstand a gate to source voltage greater than $V_{IGATE(ON)}$ (15V maximum) or the maximum regulated voltage at the IID pin, whichever is less. A few appropriate external PMOS for a number of different requirements are shown at Table 1.

Table 1. PMOS

PART NUMBER	$R_{DS(ON)}$ AT $V_{GS} = 10V$ (Ω)	MAX ID (A)	MAX VDS (V)	MANUFACTURER
SiA923EDJ	0.054	4.5	-20	Vishay
Si9407BDY	0.120	4.7	-60	Vishay
Si4401BDY	0.014	10.5	-40	Vishay
Si4435DDY	0.024	11.4	-30	Vishay
SUD19P06-60	0.060	18.3	-60	Vishay
Si7135DP	0.004	60	-30	Vishay

Note that in general the larger the capacitance seen on the IGATE pin, the slower the response of the ideal diode driver. The fast turn off and turn on current is limited to -0.5mA and 0.7mA typical respectively ($I_{IGATE(FASTOFF)}$ and $I_{IGATE(FASTON)}$). If the driver can not react fast enough to a sudden increase in load current, most of the extra current is delivered through the body diode of the external PMOS. This increases the power dissipation momentarily. It is important to ensure that the PMOS is able to withstand this momentary increase in power dissipation.

The operation section also mentioned that an external 10M pull-up resistor is recommended between the IGATE pin and the CSP pin when the IN pin voltage is expected to be out of its operating range, at the same time that the external input ideal diode PMOS is expected to be completely turned off. Note that this additional pull-up resistor increases the forward voltage regulation of the ideal diode function ($V_{IID,CSP}$) from the typical value of 8mV.

The increase in this forward voltage is calculated according to the following formula:

$$\Delta V_{IID,CSP\ REG} = V_{GSON} \cdot 20k/R_{IGATE}$$

where V_{GSON} is the source to gate voltage required to achieve the desired ON resistance of the external PMOS and R_{IGATE} is the external pull-up resistor from the IGATE

pin to the CSP pin. Therefore, for a 10M R_{IGATE} resistor and assuming a 10V V_{GSON} , the additional forward voltage regulation is $\Delta V_{IID,CSP\ REG} = 20mV$, and the total forward voltage regulation is 28mV (typ). It is recommended to set the R_{IGATE} such that this additional forward voltage regulation value does not exceed 40mV.

Input Current Limit Setting and Monitoring

The regulated input current limit is set using a resistor at the IL pin according to the following formula:

$$R_{IS} = \frac{V_{IL}}{20 \cdot I_{ILIM}}$$

where V_{IL} is the voltage on the IL pin. The IL pin is internally pulled up with an accurate current source of 50 μ A. Therefore an equivalent formula to obtain the input current limit is:

$$R_{IL} = \frac{I_{LIM} \cdot R_{IS}}{2.5\mu A} \Rightarrow I_{LIM} = \frac{R_{IL}}{R_{IS}} \cdot 2.5\mu A$$

The input current through the sense resistor is available for monitoring through the IIMON pin. The voltage on the IIMON pin varies with the current through the sense resistor as follows:

$$V_{IIMON} = 20 \cdot I_{RIS} \cdot R_{IS} = 20 \cdot (V_{IN} - V_{CLN})$$

The regulation voltage level at the IIMON pin is clamped at 1V with an accurate internal reference. At 1V on the IIMON pin, the input current limit is regulated at the following value:

$$I_{LIM(MAX)}(A) = \frac{0.050V}{R_{IS}(\Omega)}$$

When this maximum current limit is desired, leave the IL pin open or set it to a voltage >1.05V such that amplifier A4 can regulate the IIMON voltage accurately to the internal reference of 1V.

If the input current is noisy, add a filter capacitor to the CLN pin to reduce the AC content. For example, when using a buck DC/DC converter, the use of a C_{CLN} capacitor is strongly recommended. Where the highest accuracy is important, pick the value of C_{CLN} such that the AC content is less than or equal to 50% of the average voltage across the sense resistor.

APPLICATIONS INFORMATION

The voltage on the IIMON pin can be filtered further by putting a capacitor on the pin (C_{IIMON}). The voltage on the IIMON pin is also the feedback input to the input current regulation error amplifier. Any capacitor connected to this pin places a pole in the input current regulation loop. Therefore, this filter capacitor should NOT be arbitrarily large as it will slow down the overall compensated loop. For details on loop compensation please refer to the Compensation section.

Charge Current Limit Setting and Monitoring

The regulated full charge current is set according to the following formula:

$$R_{CS} = \frac{V_{CL}}{20 \cdot I_{CLIM}}$$

where V_{CL} is the voltage on the CL pin. The CL pin is internally pulled up with an accurate current source of $50\mu A$. Therefore, an equivalent formula to obtain the input current limit is:

$$R_{CL} = \frac{I_{CLIM} \cdot R_{CS}}{2.5\mu A} \Rightarrow I_{CLIM} = \frac{R_{CL}}{R_{CS}} \cdot 2.5\mu A$$

The charge current through the sense resistor is available for monitoring through the IBMON pin. The voltage on the IBMON pin varies with the current through the sense resistor as follows:

$$V_{IBMON} = 20 \cdot I_{RCS} \cdot R_{CS} = 20 \cdot (V_{CSP} - V_{CSN})$$

Similar to the IIMON pin, the regulation voltage level at the IBMON pin is clamped at 1V with an accurate internal reference. At 1V on the IBMON pin, the charge current limit is regulated to the following value:

$$I_{CLIM(MAX)}(A) = \frac{0.050V}{R_{CS}(\Omega)}$$

When this maximum charge current limit is desired, leave the CL pin open or set it to a voltage $>1.05V$ such that amplifier A5 can regulate the IBMON pin voltage accurately to the internal reference of 1V.

When the output current waveform of the DC/DC converter or the system load current is noisy, it is recommended that a capacitor is connected to the CSP pin (C_{CSP}). This is to

reduce the AC content of the current through the sense resistor (R_{CS}). Where the highest accuracy is important, pick the value of C_{CSP} such that the AC content is less than or equal to 50% of the average voltage across the sense resistor. Similar to the IIMON pin, the voltage on the IBMON pin is filtered further by putting a capacitor on the pin (C_{IBMON}). This filter capacitor should *not* be arbitrarily large as it will slow down the overall compensated charge current regulation loop. For details on the loop compensation, refer to the Compensation section.

Battery Float Voltage Programming

When the value of R_{BFB1} is much larger than 100Ω , the final float voltage is determined using the following formula:

$$R_{BFB1} = \left(\frac{V_{FLOAT}}{1.136V} - 1 \right) R_{BFB2}$$

When higher accuracy is important, a slightly more accurate final float voltage can be determined using the following formula:

$$V_{FLOAT} = \left(\frac{R_{BFB1} + R_{BFB2}}{R_{BFB2}} \cdot 1.136V \right) - \left(\frac{R_{BFB1}}{R_{BFB2}} \cdot V_{FBG} \right)$$

where V_{FBG} is the voltage at the FBG pin during float voltage regulation, which accounts for all the current from all resistor dividers that are connected to this pin ($R_{FBG} = 100\Omega$ typical).

Low Battery Trickle Charge Programming and Bad Battery Detection

When charging into an over-discharged or dead battery ($V_{BFB} < V_{LOBAT}$), the pull-up current at the CL pin is reduced to 10% of the normal pull-up current. Therefore, the trickle charge current is set using the following formula:

$$R_{CL} = \frac{I_{CLIM(TRKL)} \cdot R_{CS}}{0.25\mu A} \Rightarrow I_{CLIM(TRKL)} = 0.25\mu A \cdot \frac{R_{CL}}{R_{CS}}$$

Therefore, when $50\mu A \cdot R_{CL}$ is less than 1V, the following relation is true:

$$I_{CLIM(TRKL)} = \frac{I_{CLIM}}{10}$$

APPLICATIONS INFORMATION

Once the battery voltage rises above the low battery voltage threshold, the charge current level rises from the trickle charge current level to the full charge current level.

The LTC4000 also features bad battery detection. This detection is disabled if the TMR pin is grounded or tied to BIAS. However, when a capacitor is connected to the TMR pin, a bad battery detection timer is started as soon as trickle charging starts. If at the end of the bad battery detection time the battery voltage is still lower than the low battery threshold, charging is terminated and the part indicates a bad battery condition by pulling the $\overline{\text{FLT}}$ pin low and leaving the $\overline{\text{CHRG}}$ pin high impedance.

The bad battery detection time can be programmed according to the following formula:

$$C_{\text{TMR}} (\text{nF}) = t_{\text{BADBAT}} (\text{h}) \cdot 138.5$$

Note that once a bad battery condition is detected, the condition is latched. In order to re-enable charging, remove the battery and connect a new battery whose voltage causes BFB to rise above the recharge battery threshold ($V_{\text{RECHRG(RISE)}}$). Alternatively toggle the ENC pin or remove and reapply power to IN.

C/X Detection, Charge Termination and Automatic Recharge

Once the constant voltage charging is reached, there are two ways in which charging can terminate. If the TMR pin is tied to BIAS, the battery charger terminates as soon as the charge current drops to the level programmed by the CX pin. The C/X current termination level is programmed according to the following formula:

$$R_{\text{CX}} = \frac{(I_{\text{C/X}} \cdot R_{\text{CS}}) + 0.5\text{mV}}{0.25\mu\text{A}} \Rightarrow I_{\text{C/X}} = \frac{(0.25\mu\text{A} \cdot R_{\text{CX}}) - 0.5\text{mV}}{R_{\text{CS}}}$$

where R_{CS} is the charge current sense resistor connected between the CSP and the CSN pins.

When the voltage at BFB is higher than the recharge threshold (97.6% of float), the C/X comparator is enabled. In order to ensure proper C/X termination coming out of a paused charging condition, connect a capacitor on the CX pin according to the following formula:

$$C_{\text{CX}} = 100C_{\text{BGATE}}$$

where C_{BGATE} is the total capacitance connected to the BGATE pin.

For example, a typical capacitance of 1nF requires a capacitor greater than 100nF connected to the CX pin to ensure proper C/X termination behavior.

If a capacitor is connected to the TMR pin, as soon as the constant voltage charging is achieved, a charge termination timer is started. When the charge termination timer expires, the charge cycle terminates. The total charge termination time can be programmed according to the following formula:

$$C_{\text{TMR}} (\text{nF}) = t_{\text{TERMINATE}} (\text{h}) \cdot 34.6$$

If the TMR pin is grounded, charging never terminates and the battery voltage is held at the float voltage. Note that regardless of which termination behavior is selected, the $\overline{\text{CHRG}}$ and $\overline{\text{FLT}}$ pins will both assume a high impedance state as soon as the charge current falls below the programmed C/X level.

After the charger terminates, the LTC4000 automatically restarts another charge cycle if the battery feedback voltage drops below 97.1% of the programmed final float voltage ($V_{\text{RECHRG(FALL)}}$). When charging restarts, the $\overline{\text{CHRG}}$ pin pulls low and the $\overline{\text{FLT}}$ pin remains high impedance.

Output Voltage Regulation Programming

The output voltage regulation level is determined using the following formula:

$$R_{\text{OFB1}} = \left(\frac{V_{\text{OUT}}}{1.193} - 1 \right) \cdot R_{\text{OFB2}}$$

As in the battery float voltage calculation, when higher accuracy is important, a slightly more accurate output is determined using the following formula:

$$V_{\text{OUT}} = \left(\frac{R_{\text{OFB1}} + R_{\text{OFB2}} \cdot 1.193\text{V}}{R_{\text{OFB2}}} \right) \cdot \left(\frac{R_{\text{OFB1}}}{R_{\text{OFB2}}} \cdot V_{\text{FBG}} \right)$$

where V_{FBG} is the voltage at the FBG pin during output voltage regulation, which accounts for all the current from all resistor dividers that are connected to this pin.

APPLICATIONS INFORMATION

Battery Instant-On and Ideal Diode External PMOS Consideration

The instant-on voltage level is determined using the following formula:

$$V_{OUT(INST_ON)} = \frac{R_{OFB1} + R_{OFB2}}{R_{OFB2}} \cdot 0.974V$$

Note that R_{OFB1} and R_{OFB2} are the same resistors that program the output voltage regulation level. Therefore, the output voltage regulation level is always 122.5% of the instant-on voltage level.

During instant-on operation, it is critical to consider the charging PMOS power dissipation. When the battery voltage is below the low battery threshold (V_{LOBAT}), the power dissipation in the PMOS can be calculated as follows:

$$P_{TRKL} = [0.86 \cdot V_{FLOAT} - V_{BAT}] \cdot I_{CLIM(TRKL)}$$

where $I_{CLIM(TRKL)}$ is the trickle charge current limit.

On the other hand, when the battery voltage is above the low battery threshold but still below the instant-on threshold, the power dissipation can be calculated as follows:

$$P_{INST_ON} = [0.86 \cdot V_{FLOAT} - V_{BAT}] \cdot I_{CLIM}$$

where I_{CLIM} is the full scale charge current limit.

For example, when charging a 3-cell Lithium Ion battery with a programmed full charged current of 1A, the float voltage is 12.6V, the bad battery voltage level is 8.55V and the instant-on voltage level is 10.8V. During instant-on operation and in the trickle charge mode, the worst case maximum power dissipation in the PMOS is 1.08W. When the battery voltage is above the bad battery voltage level, then the worst case maximum power dissipation is 2.25W.

When overheating of the charging PMOS is a concern, it is recommended that the user add a temperature detection circuit that pulls down on the NTC pin. This pauses charging whenever the external PMOS temperature is too high. A sample circuit that performs this temperature detection function is shown in Figure 7.

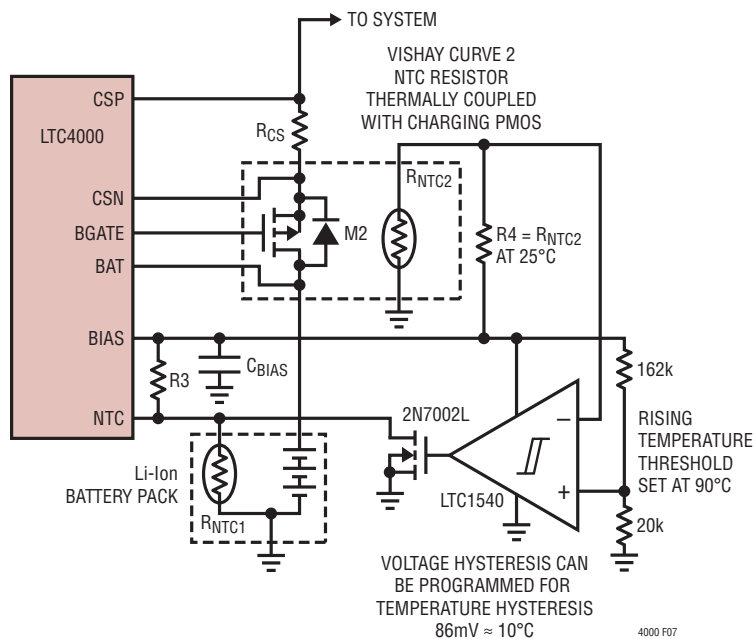

Figure 7. Charging PMOS Overtemperature Detection Circuit Protecting PMOS from Overheating

APPLICATIONS INFORMATION

Similar to the input external PMOS, the charging external PMOS must be able to withstand a gate to source voltage greater than $V_{BGATE(ON)}$ (15V maximum) or the maximum regulated voltage at the CSP pin, whichever is less. Consider the expected maximum current, power dissipation and instant-on voltage drop when selecting this PMOS. The PMOS suggestions in Table 1 are an appropriate starting point depending on the application.

Float Voltage, Output Voltage and Instant-On Voltage Dependencies

The formulas for setting the float voltage, output voltage and instant-on voltage are repeated here:

$$V_{FLOAT} = \frac{R_{BFB1} + R_{BFB2}}{R_{BFB2}} \cdot 1.136V$$

$$V_{OUT} = \frac{R_{OFB1} + R_{OFB2}}{R_{OFB2}} \cdot 1.193V$$

$$V_{OUT(INST_ON)} = \frac{R_{OFB1} + R_{OFB2}}{R_{OFB2}} \cdot 0.974V$$

In the typical application, V_{OUT} is set higher than V_{FLOAT} to ensure that the battery is charged fully to its intended float voltage. On the other hand, V_{OUT} should not be programmed too high since $V_{OUT(INST_ON)}$, the minimum voltage on CSP, depends on the same resistors R_{OFB1} and R_{OFB2} that set V_{OUT} . As noted before, this means that the output voltage regulation level is always 122.5% of the instant-on voltage. The higher the programmed value of $V_{OUT(INST_ON)}$, the larger the operating region when the charger PMOS is driven in the linear region where it is less efficient.

If R_{OFB1} and R_{OFB2} are set to be equal to R_{BFB1} and R_{BFB2} respectively, then the output voltage is set at 105% of the float voltage and the instant-on voltage is set at 86% of the float voltage. Figure 8 shows the range of possible output voltages that can be set for $V_{OUT(INST_ON)}$ and V_{OUT} with respect to V_{FLOAT} to ensure the battery can be fully charged in an ideal scenario.

Taking into account possible mismatches between the resistor dividers as well as mismatches in the various regulation loops, V_{OUT} should not be programmed to be less than 105% of V_{FLOAT} to ensure that the battery can be fully charged. This automatically means that the instant-on voltage level should not be programmed to be less than 86% of V_{FLOAT} .

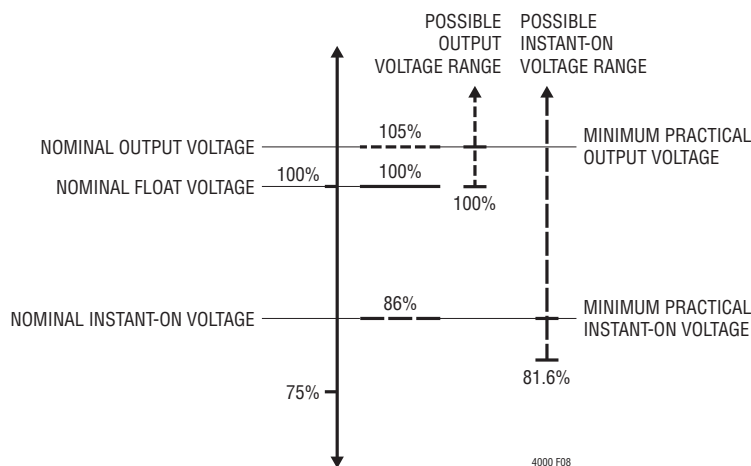

Figure 8. Possible Voltage Ranges for V_{OUT} and $V_{OUT(INST_ON)}$ in Ideal Scenario

APPLICATIONS INFORMATION

Battery Temperature Qualified Charging

To use the battery temperature qualified charging feature, connect an NTC thermistor, R_{NTC} , between the NTC pin and the GND pin, and a bias resistor, R_3 , from the BIAS pin to the NTC pin (Figure 9). Thermistor manufacturer datasheets usually include either a temperature lookup table or a formula relating temperature to the resistor value at that corresponding temperature.

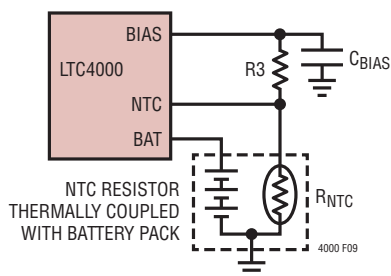

Figure 9. NTC Thermistor Connection

In a simple application, R_3 is a 1% resistor with a value equal to the value of the chosen NTC thermistor at 25°C (R_{25}). In this simple setup, the LTC4000 will pause charging when the resistance of the NTC thermistor drops to 0.54 times the value of R_{25} . For a Vishay Curve 2 thermistor, this corresponds to approximately 41.5°C. As the temperature drops, the resistance of the NTC thermistor rises. The LTC4000 is also designed to pause charging when the value of the NTC thermistor increases to three times the value of R_{25} . For a Vishay Curve 2 thermistor, this corresponds to approximately -1.5°C. With Vishay Curve 2 thermistor, the hot and cold comparators each have approximately 5°C of hysteresis to prevent oscillation about the trip point.

The hot and cold threshold can be adjusted by changing the value of R_3 . Instead of simply setting R_3 to be equal to R_{25} , R_3 is set according to one of the following formulas:

$$R_3 = \frac{R_{NTC} \text{ at cold_threshold}}{3}$$

or

$$R_3 = 1.857 \cdot R_{NTC} \text{ at hot_threshold}$$

Notice that with only one degree of freedom (i.e. adjusting the value of R_3), the user can only use one of the formulas above to set either the cold or hot threshold but not both. If the value of R_3 is set to adjust the cold threshold, the value of the NTC resistor at the hot threshold is then equal to $0.179 \cdot R_{NTC}$ at cold_threshold. Similarly, if the value of R_3 is set to adjust the hot threshold, the value of the NTC resistor at the cold threshold is then equal to $5.571 \cdot R_{NTC}$ at cold_threshold.

Note that changing the value of R_3 to be larger than R_{25} will move both the hot and cold threshold lower and vice versa. For example, using a Vishay Curve 2 thermistor whose nominal value at 25°C is 100k, the user can set the cold temperature to be at 5°C by setting the value of $R_3 = 75k$, which automatically then sets the hot threshold at approximately 50°C.

It is possible to adjust the hot and cold threshold independently by introducing another resistor as a second degree of freedom (Figure 10). The resistor R_D in effect reduces the sensitivity of the resistance between the NTC pin and ground. Therefore, intuitively this resistor will move the hot threshold to a hotter temperature and the cold threshold to a colder temperature.

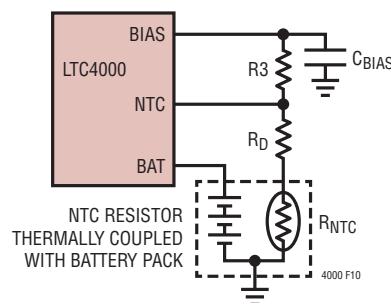

Figure 10. NTC Thermistor Connection with Desensitizing Resistor R_D

APPLICATIONS INFORMATION

The value of R_3 and R_D can now be set according to the following formula:

$$R_3 = \frac{R_{NTC} \text{ at cold_threshold} - R_{NTC} \text{ at hot_threshold}}{2.461}$$

$$R_D = 0.219 \cdot R_{NTC} \text{ at cold_threshold} - 1.219 \cdot R_{NTC} \text{ at hot_threshold}$$

Note the important caveat that this method can only be used to desensitize the thermal effect on the thermistor and hence push the hot and cold temperature thresholds apart from each other. When using the formulas above, if the user finds that a negative value is needed for R_D , the two temperature thresholds selected are too close to each other and a higher sensitivity thermistor is needed.

For example, this method can be used to set the hot and cold thresholds independently to 60°C and -5°C. Using a Vishay Curve 2 thermistor whose nominal value at 25°C is 100k, the formula results in $R_3 = 130k$ and $R_D = 41.2k$ for the closest 1% resistors values.

To increase thermal sensitivity such that the valid charging temperature band is much smaller than 40°C, it is possible to put a PTC (positive thermal coefficient) resistor in series with R_3 between the BIAS pin and the NTC pin. This PTC resistor also needs to be thermally coupled with the battery. Note that this method increases the number of thermal sensing connections to the battery pack from one wire to three wires. The exact value of the nominal PTC resistor required can be calculated using a similar method as described above, keeping in mind that the threshold at the NTC pin is always 75% and 35% of V_{BIAS} .

Leaving the NTC pin floating or connecting it to a capacitor disables all NTC functionality.

The \overline{FLT} and \overline{CHRG} Indicator Pins

The \overline{FLT} and \overline{CHRG} pins in the LTC4000 provide status indicators. Table 2 summarizes the mapping of the pin states to the part status.

Table 2. \overline{FLT} and \overline{CHRG} Status Indicator

\overline{FLT}	\overline{CHRG}	STATUS
0	0	NTC Over Ranged – Charging Paused
1	0	Charging Normally
0	1	Charging Terminated and Bad Battery Detected
1	1	$V_{IBMON} < (V_{CX} - 10mV)$

where 1 indicates a high impedance state and 0 indicates a low impedance pull-down state.

Note that $V_{IBMON} < (V_{CX} - 10mV)$ corresponds to charge termination only if the C/X termination is selected. If the charger timer termination is selected, constant voltage charging may continue for the remaining charger timer period even after the indicator pins indicate that $V_{IBMON} < (V_{CX} - 10mV)$. This is also true when no termination is selected, constant voltage charging will continue even after the indicator pins indicate that $V_{IBMON} < (V_{CX} - 10mV)$.

The BIAS Pin

For ease of use the LTC4000 provides a low dropout voltage regulator output on the BIAS pin. Designed to provide up to 0.5mA of current at 2.9V, this pin requires at least 470nF of low ESR bypass capacitance for stability.

Use the BIAS pin as the pull-up source for the NTC resistor networks, since the internal reference for the NTC circuitry is based on a ratio of the voltage on the BIAS pin. Furthermore, various 100k pull-up resistors can be conveniently connected to the BIAS pin.

APPLICATIONS INFORMATION

Setting the Input Voltage Monitoring Resistor Divider

The falling threshold voltage level for this monitoring function can be calculated as follows:

$$R_{VM1} = \left(\frac{V_{VM_RST}}{1.193V} - 1 \right) \cdot R_{VM2}$$

where R_{VM1} and R_{VM2} form a resistor divider connected between the monitored voltage and GND, with the center tap point connected to the VM pin as shown in Figure 6. The rising threshold voltage level can be calculated similarly.

Compensation

In order for the LTC4000 to control the external DC/DC converter, it has to be able to overcome the sourcing bias current of the ITH or VC pin of the DC/DC converter. The typical sinking capability of the LTC4000 at the ITH pin is 1mA at 0.4V with a maximum voltage range of 0V to 6V.

It is imperative that the local feedback of the DC/DC converter be set up such that during regulation of any of the LTC4000 loops this local loop is out of regulation and sources as much current as possible from its ITH/VC pin. For example for a DC/DC converter regulating its output voltage, it is recommended that the converter feedback divider is programmed to be greater than 110% of the output voltage regulation level programmed at the OFB pin.

There are four feedback loops to consider when setting up the compensation for the LTC4000. As mentioned before these loops are: the input current loop, the charge current loop, the float voltage loop and the output voltage loop. All of these loops have an error amp (A4-A7) followed by another amplifier (A10) with the intermediate node driving the CC pin and the output of A10 driving the ITH pin as shown in Figure 11. The most common compensation network of a series capacitor (C_C) and resistor (R_C) between the CC pin and the ITH pin is shown here.

Each of the loops has slightly different dynamics due to differences in the feedback signal path. The analytic description of each of the loops is included in the Appendix section. In most situations, an alternative empirical approach to compensation, as described here, is more practical.

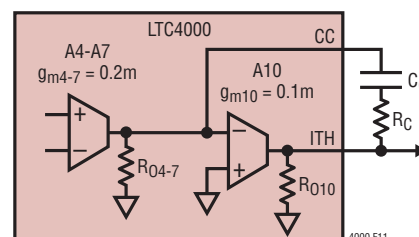

Figure 11. Error Amplifier Followed by Output Amplifier Driving CC and ITH Pins

Empirical Loop Compensation

Based on the five analytical expressions given in the Appendix section, and the transfer function from the ITH pin to the input and output current of the external DC/DC converter, the user can analytically determine the complete loop transfer function of each of the loops. Once these are obtained, it is a matter of analyzing the gain and phase bode plots to ensure that there is enough phase and gain margin at unity crossover with the selected values of R_C and C_C for all operating conditions.

Even though it is clear that an analytical compensation method is possible, sometimes certain complications render this method difficult to tackle. These complications include the lack of easy availability of the switching converter transfer function from the ITH or VC control node to its input or output current, and the variability of parameter values of the components such as the ESR of the output capacitor or the $R_{DS(ON)}$ of the external PFETs.

Therefore a simpler and more practical way to compensate the LTC4000 is provided here. This empirical method involves injecting an AC signal into the loop, observing the loop transient response and adjusting the C_C and R_C values to quickly iterate towards the final values. Much of the detail of this method is derived from Application Note 19 which can be found at www.linear.com using AN19 in the search box.

Figure 12 shows the recommended setup to inject an AC-coupled output load variation into the loop. A function generator with 50 Ω output impedance is coupled through a 50 Ω /1000 μ F series RC network to the regulator output.

APPLICATIONS INFORMATION

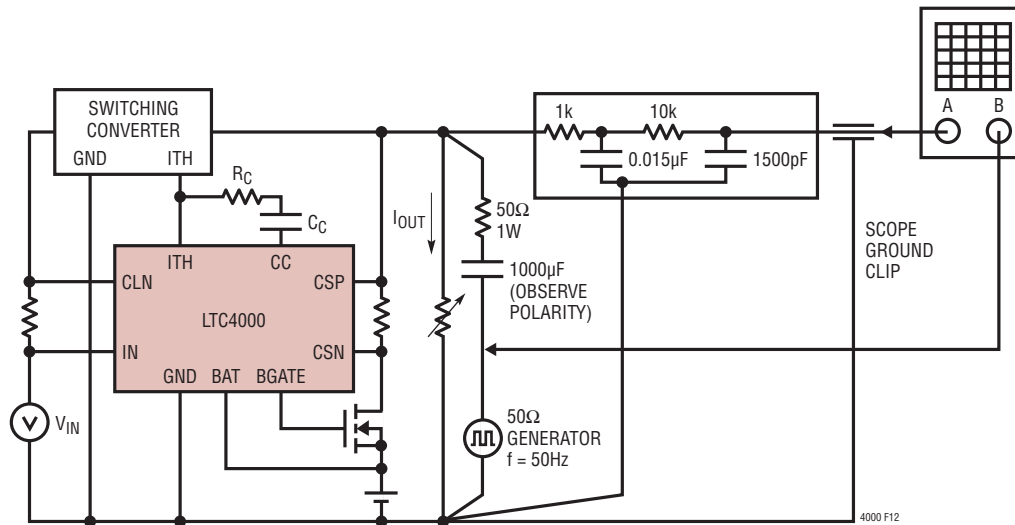

Figure 12. Empirical Loop Compensation Setup

Generator frequency is set at 50Hz. Lower frequencies may cause a blinking scope display and higher frequencies may not allow sufficient settling time for the output transient. Amplitude of the generator output is typically set at $5V_{P-P}$ to generate a $100mA_{P-P}$ load variation. For lightly loaded outputs ($I_{OUT} < 100mA$), this level may be too high for small signal response. If the positive and negative transition settling waveforms are significantly different, amplitude should be reduced. Actual amplitude is not particularly important because it is the shape of the resulting regulator output waveform which indicates loop stability.

A 2-pole oscilloscope filter with $f = 10kHz$ is used to block switching frequencies. Regulators without added LC output filters have switching frequency signals at their outputs which may be much higher amplitude than the low frequency settling waveform to be studied. The filter frequency is high enough for most applications to pass the settling waveform with no distortion.

Oscilloscope and generator connections should be made exactly as shown in Figure 12 to prevent ground loop errors. The oscilloscope is synced by connecting the channel B probe to the generator output, with the ground clip

of the second probe connected to exactly the same place as channel A ground. The standard 50Ω BNC sync output of the generator should not be used because of ground loop errors. It may also be necessary to isolate either the generator or oscilloscope from its third wire (earth ground) connection in the power plug to prevent ground loop errors in the scope display. These ground loop errors are checked by connecting channel A probe tip to exactly the same point as the probe ground clip. Any reading on channel A indicates a ground loop problem.

Once the proper setup is made, finding the optimum values for the frequency compensation network is fairly straightforward. Initially, C_C is made large ($\geq 1\mu F$) and R_C is made small ($\approx 10k$). This nearly always ensures that the regulator will be stable enough to start iteration. Now, if the regulator output waveform is single-pole over damped (see the waveforms in Figure 13), the value of C_C is reduced in steps of about 2:1 until the response becomes slightly under damped. Next, R_C is increased in steps of 2:1 to introduce a loop zero. This will normally improve damping and allow the value of C_C to be further reduced. Shifting back and forth between R_C and C_C variations will allow one to quickly find optimum values.

APPLICATIONS INFORMATION

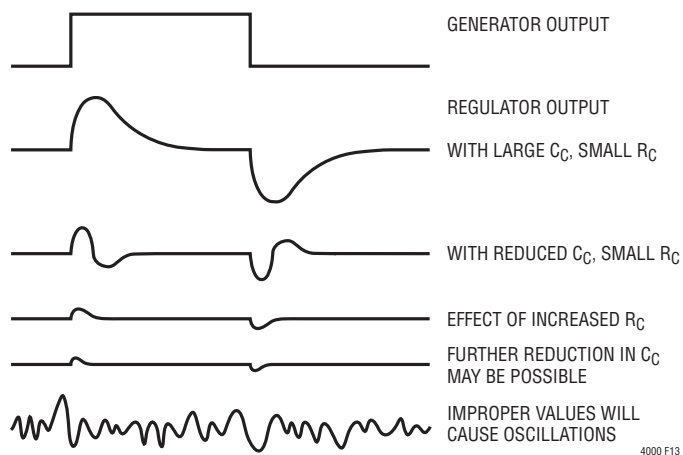

Figure 13. Typical Output Transient Response at Various Stability Level

If the regulator response is under damped with the initial large value of C_C , R_C should be increased immediately before larger values of C_C are tried. This will normally bring about the over damped starting condition for further iteration.

The optimum values for R_C and C_C normally means the smallest value for C_C and the largest value for R_C which still guarantee well damped response, and which result in the largest loop bandwidth and hence loop settling that is as rapid as possible. The reason for this approach is that it minimizes the variations in output voltage caused by input ripple voltage and output load transients.

A switching regulator which is grossly over damped will never oscillate, but it may have unacceptably large output transients following sudden changes in input voltage or output loading. It may also suffer from excessive overshoot

problems on startup or short circuit recovery. To guarantee acceptable loop stability under all conditions, the initial values chosen for R_C and C_C should be checked under all conditions of input voltage and load current. The simplest way of accomplishing this is to apply load currents of minimum, maximum and several points in between. At each load current, input voltage is varied from minimum to maximum while observing the settling waveform.

If large temperature variations are expected for the system, stability checks should also be done at the temperature extremes. There can be significant temperature variations in several key component parameters which affect stability; in particular, input and output capacitor value and their ESR, and inductor permeability. The external converter parametric variations also need some consideration especially the transfer function from the ITH/VC pin voltage to the output variable (voltage or current). The LTC4000 parameters that vary with temperature include the transconductance and the output resistance of the error amplifiers (A4-A7). For modest temperature variations, conservative over damping under worst-case room temperature conditions is usually sufficient to guarantee adequate stability at all temperatures.

One measure of stability margin is to vary the selected values of both R_C and C_C by 2:1 in all four possible combinations. If the regulator response remains reasonably well damped under all conditions, the regulator can be considered fairly tolerant of parametric variations. Any tendency towards an under damped (ringing) response indicates that a more conservative compensation may be needed.

APPLICATIONS INFORMATION

DESIGN EXAMPLE

In this design example, the LTC4000 is paired with the LT3845A buck converter to create a 10A, 3-cell LiFePO₄ battery charger. The circuit is shown on the front page and is repeated here in Figure 14.

- The input voltage monitor falling threshold is set at 14.3V according to the following formula:

$$R_{VM1} = \left(\frac{14.3V}{1.193V} - 1 \right) \cdot 100k\Omega \approx 1.10M\Omega$$

- The IL pin is left open such that the voltage on this pin is >1.05V. The regulation voltage on the IIMON pin is clamped at 1.0V with an accurate internal reference. Therefore, the input current limit is set at 10A according to the following formula:

$$R_{IS} = \frac{0.050V}{10A} = 5m\Omega$$

- R_{CL} is set at 24.9kΩ such that the voltage at the CL pin is 1.25V. Similar to the IIMON pin, the regulation voltage on the IBMON pin is clamped at 1V with an accurate internal reference. Therefore, the charge current limit is set at 10A according to the following formula:

$$I_{CLIM(MAX)} = \frac{0.050V}{R_{CS}} = \frac{0.050V}{5m\Omega} = 10A$$

- The trickle charge current level is consequently set at 1.25A, according to the following formula:

$$I_{CLIM(TRKL)} = 0.25\mu A \cdot \frac{24.9k\Omega}{5m\Omega} = 1.25A$$

- The battery float voltage is set at 10.8V according to the following formula:

$$R_{BFB1} = \left(\frac{10.8}{1.136} - 1 \right) \cdot 133k\Omega \approx 1.13M\Omega$$

- The bad battery detection time is set at 43 minutes according to the following formula:

$$C_{TMR}(nF) = t_{BADBAT}(h) \cdot 138.5 = \frac{43}{60} \cdot 138.5 = 100nF$$

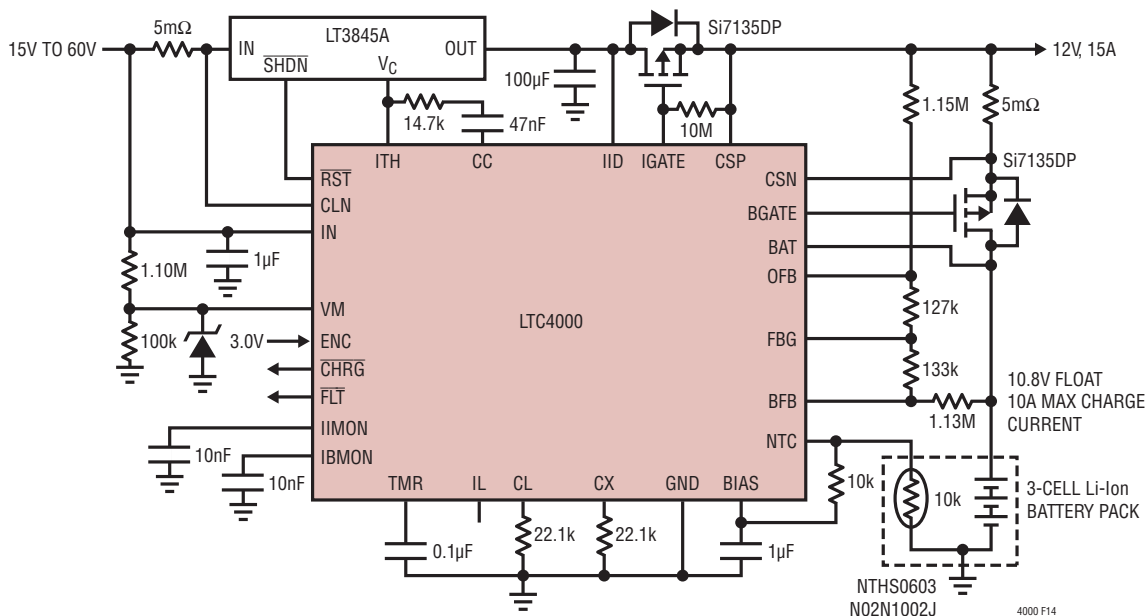

Figure 14. 48V to 10.8V at 10A Buck Converter Charger for Three LiFePO₄ Cells

APPLICATIONS INFORMATION

- The charge termination time is set at 2.9 hours according to the following formula:

$$C_{TMR}(\text{nF}) = t_{\text{TERMINATE}}(\text{h}) \cdot 34.6 = 2.9 \cdot 34.6 = 100\text{nF}$$

- The C/X current termination level is programmed at 1A according to the following formula:

$$R_{CX} = \frac{(1\text{A} \cdot 5\text{m}\Omega) + 0.5\text{mV}}{0.25\mu\text{A}} \approx 22.1\text{k}\Omega$$

Note that in this particular solution, the timer termination is selected since a capacitor connects to the TMR pin. Therefore, this C/X current termination level only applies to the $\overline{\text{CHRG}}$ indicator pin.

- The output voltage regulation level is set at 12V according to the following formula:

$$R_{\text{OFB1}} = \left(\frac{12}{1.193} - 1 \right) \cdot 127\text{k}\Omega \approx 1.15\text{M}\Omega$$

- The instant-on voltage level is consequently set at 9.79V according to the following formula:

$$V_{\text{INST_ON}} = \frac{1150\text{k}\Omega + 127\text{k}\Omega}{127\text{k}\Omega} \cdot 0.974\text{V} = 9.79\text{V}$$

The worst-case power dissipation during instant-on operation can be calculated as follows:

- During trickle charging:

$$\begin{aligned} P_{\text{TRKL}} &= [0.86 \cdot V_{\text{FLOAT}} - V_{\text{BAT}}] \cdot I_{\text{CLIM_TRKL}} \\ &= [0.86 \cdot 10.8] \cdot 1\text{A} \\ &= 9.3\text{W} \end{aligned}$$

- And beyond trickle charging:

$$\begin{aligned} P_{\text{INST_ON}} &= [0.86 \cdot V_{\text{FLOAT}} - V_{\text{BAT}}] \cdot I_{\text{CLIM}} \\ &= [0.86 \cdot 10.8 - 7.33] \cdot 10\text{A} \\ &= 19.3\text{W} \end{aligned}$$

Therefore, depending on the layout and heat sink available to the charging PMOS, the suggested PMOS over temperature detection circuit included in Figure 7 may need to be included. For the complete application circuit, please refer to Figure 25.

- The range of valid temperature for charging is set at -1.5°C to 41.5°C by picking a 10k Vishay Curve 2 NTC thermistor that is thermally coupled to the battery, and connecting this in series with a regular 10k resistor to the BIAS pin.
- For compensation, the procedure described in the empirical loop compensation section is followed. As recommended, first a $1\mu\text{F}$ C_C and 10k R_C is used, which sets all the loops to be stable. For an example of typical transient responses, the charge current regulation loop when V_{OFB} is regulated to $V_{\text{OUT(INST_ON)}}$ is used here. Figure 15 shows the recommended setup to inject a DC-coupled charge current variation into this particular loop. The input to the CL pin is a square wave at 70Hz with the low level set at 120mV and the high level set at 130mV, corresponding to a 1.2A and 1.3A charge current (100mA charge current step). Therefore, in this particular example the trickle charge current regulation stability is examined. Note that the nominal trickle charge current in this example is programmed at 1.25A ($R_{\text{CL}} = 24.9\text{k}\Omega$).

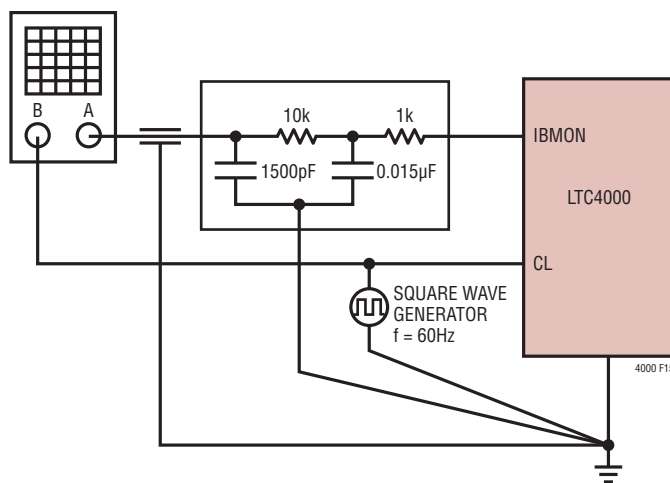

Figure 15. Charge Current Regulation Loop Compensation Setup

APPLICATIONS INFORMATION

With $C_C = 1\mu\text{F}$, $R_C = 10\text{k}$ at $V_{\text{IN}} = 20\text{V}$, $V_{\text{BAT}} = 7\text{V}$, V_{CSP} regulated at 9.8V and a 0.2A output load condition at CSP, the transient response for a 100mA charge current step observed at IBMON is shown in Figure 16.

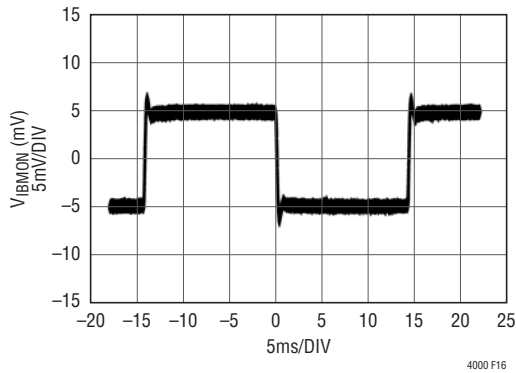

Figure 16. Transient Response of Charge Current Regulation Loop Observed at IBMON When V_{OFB} is Regulated to $V_{\text{OUT(INST_ON)}}$ with $C_C = 1\mu\text{F}$, $R_C = 10\text{k}$ for a 100mA Charge Current Step

The transient response shows a small overshoot with slow settling indicating a fast minor loop within a well damped overall loop. Therefore, the value of C_C is reduced iteratively until $C_C = 22\text{nF}$. The transient response of the same loop with $C_C = 22\text{nF}$ and $R_C = 10\text{k}$ is shown in Figure 17.

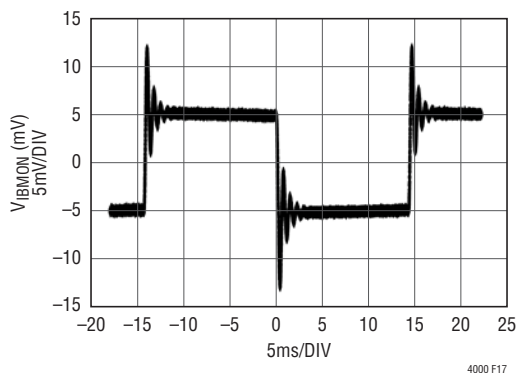

Figure 17. Transient Response of Charge Current Regulation Loop Observed at IBMON When V_{OFB} is Regulated to $V_{\text{OUT(INST_ON)}}$ with $C_C = 22\text{nF}$, $R_C = 10\text{k}$ for a 100mA Charge Current Step

The transient response now indicates an overall under damped system. As noted in the empirical loop compensation section, the value of R_C is now increased iteratively until $R_C = 20\text{k}$. The transient response of the same loop with $C_C = 22\text{nF}$ and $R_C = 20\text{k}$ is shown in Figure 18.

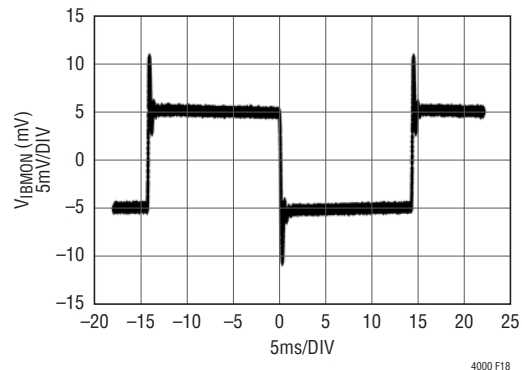

Figure 18. Transient Response of Charge Current Regulation Loop Observed at IBMON When V_{OFB} is Regulated to $V_{\text{OUT(INST_ON)}}$ with $C_C = 22\text{nF}$, $R_C = 20\text{k}$ for a 100mA Charge Current Step

Note that the transient response is close to optimum with some overshoot and fast settling. If after iteratively increasing the value of R_C , the transient response again indicates an over damped system, the step of reducing C_C can be repeated. These steps of reducing C_C followed by increasing R_C can be repeated continuously until one arrives at a stable loop with the smallest value of C_C and the largest value of R_C . In this particular example, these values are found to be $C_C = 22\text{nF}$ and $R_C = 20\text{k}\Omega$.

After arriving at these final values of R_C and C_C , the stability margin is checked by varying the values of both R_C and C_C by 2:1 in all four possible combinations. After which the setup condition is varied, including varying the input voltage level and the output load level and the transient response is checked at these different setup conditions. Once the desired responses on all different conditions are obtained, the values of R_C and C_C are noted.

APPLICATIONS INFORMATION

This same procedure is then repeated for the other four loops: the input current regulation, the output voltage regulation, the battery float voltage regulation and finally the charge current regulation when $V_{OVB} > V_{OUT(INST_ON)}$. Note that the resulting optimum values for each of the loops may differ slightly. The final values of C_C and R_C are then selected by combining the results and ensuring the most conservative response for all the loops. This usually entails picking the largest value of C_C and the smallest value of R_C based on the results obtained for all the loops. In this particular example, the value of C_C is finally set to 47nF and $R_C = 14.7k\Omega$.

BOARD LAYOUT CONSIDERATIONS

In the majority of applications, the most important parameter of the system is the battery float voltage. Therefore, the user needs to be extra careful when placing and routing the feedback resistor R_{BFB1} and R_{BFB2} . In particular, the battery sense line connected to R_{BFB1} and the ground return line for the LTC4000 must be Kelvined back to where the battery output and the battery ground are located respectively. Figure 19 shows this Kelvin sense configuration.

For accurate current sensing, the sense lines from R_{IS} and R_{CS} (Figure 19) must be Kelvined back all the way to the sense resistors terminals. The two sense lines of each resistor must also be routed close together and away from noise sources to minimize error. Furthermore, current filtering capacitors should be placed strategically to ensure that very little AC current is flowing through these sense resistors as mentioned in the applications section.

The decoupling capacitors C_{IN} and C_{BIAS} must be placed as close to the LTC4000 as possible. This allows as short a route as possible from C_{IN} to the IN and GND pins, as well as from C_{BIAS} to the BIAS and GND pins.

In a typical application, the LTC4000 is paired with an external DC/DC converter. The operation of this converter often involves high dV/dt switching voltage as well as high currents. Isolate these switching voltages and currents from the LTC4000 section of the board as much as possible by using good board layout practices. These include separating noisy power and signal grounds, having a good low impedance ground plane, shielding whenever necessary, and routing sensitive signals as short as possible and away from noisy sections of the board.

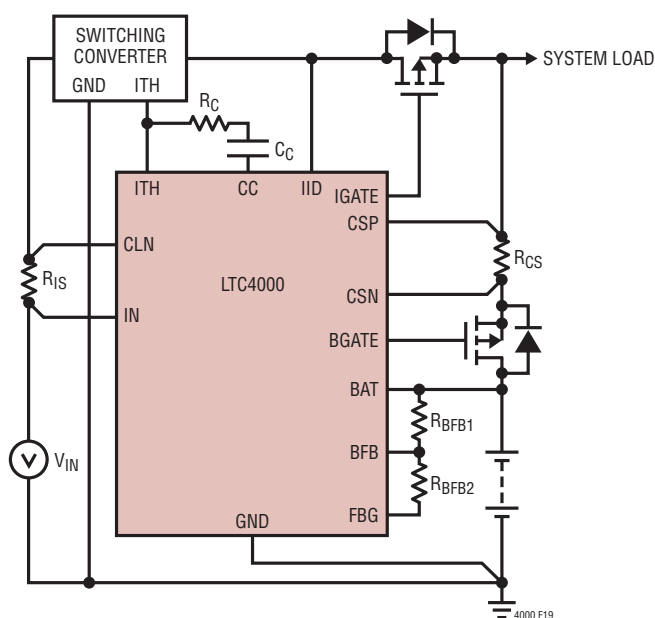

Figure 19. Kelvin Sense Lines Configuration for LTC4000

APPLICATIONS INFORMATION

APPENDIX—THE LOOP TRANSFER FUNCTIONS

When a series resistor (R_C) and capacitor (C_C) is used as the compensation network as shown in Figure 11, the transfer function from the input of A4-A7 to the ITH pin is simply as follows:

$$\frac{V_{ITH}}{V_{FB}}(s) = g_{m4-7} \left[\frac{\left(R_C - \frac{1}{g_{m10}} \right) C_C s + 1}{R_{O4-7} \cdot C_C s} \right]$$

where g_{m4-7} is the transconductance of error amplifier A4-A7, typically 0.5mA/V; g_{m10} is the output amplifier (A10) transconductance, R_{O4-7} is the output impedance of the error amplifier, typically 50mΩ; and R_{O10} is the effective output impedance of the output amplifier, typically 10mΩ with the ITH pin open circuit.

Note this simplification is valid when $g_{m10} \cdot R_{O10} \cdot R_{O4-7} \cdot C_C = A_{V10} \cdot R_{O4-7} \cdot C_C$ is much larger than any other poles or zeroes in the system. Typically $A_{V10} \cdot R_{O4-7} = 5 \cdot 10^{10}$ with the ITH pin open circuit. The exact value of g_{m10} and R_{O10} depends on the pull-up current and impedance connected to the ITH pin respectively.

In most applications, compensation of the loops involves picking the right values of R_C and C_C . Aside from picking the values of R_C and C_C , the value of g_{m10} may also be adjusted. The value of g_{m10} can be adjusted higher by increasing the pull-up current into the ITH pin and its value can be approximated as:

$$g_{m10} = \frac{I_{ITH} + 5\mu A}{50mV}$$

The higher the value of g_{m10} , the smaller the lower limit of the value of R_C would be. This lower limit is to prevent the presence of the right half plane zero.

Even though all the loops share this transfer function from the error amplifier input to the ITH pin, each of the loops has a slightly different dynamic due to differences in the feedback signal path.

The Input Current Regulation Loop

The feedback signal for the input current regulation loop is the sense voltage across the input current sense resistor (R_{IS}).

This voltage is amplified by a factor of 20 and compared to the voltage on the IL pin by the transconductance error amplifier (A4). This amplifier then drives the output transconductance amplifier (A10) to appropriately adjust the voltage on the ITH pin driving the external DC/DC converter to regulate the input current across the sense resistor (R_{IS}). This loop is shown in detail in Figure 20.

The simplified loop transmission is:

$$L_{IC}(s) = g_{m4} \left[\frac{\left(R_C - \frac{1}{g_{m10}} \right) C_C s + 1}{C_C s} \right] \cdot \left[\frac{20R_{IS} (R_{2CII}MONS + 1)}{(R1 + R2)C_{II}MONS + 1} \right] \cdot G_{mi_p}(s)$$

where $G_{mi_p}(s)$ is the transfer function from V_{ITH} to the input current of the external DC/DC converter.

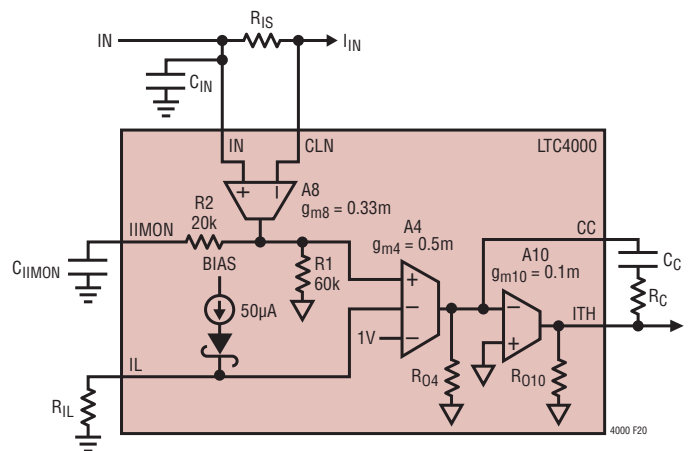

Figure 20. Simplified Linear Model of the Input Current Regulation Loop

APPLICATIONS INFORMATION

The Output Voltage Regulation Loop

The feedback signal for the output voltage regulation loop is the voltage on the OFB pin, which is connected to the center node of the resistor divider between the output voltage (connected to C_{SP}) and the FBG pin. This voltage is compared to an internal reference (1.193V typical) by the transconductance error amplifier A7. This amplifier then drives the output transconductance amplifier (A10) to appropriately adjust the voltage on the ITH pin driving the external DC/DC converter to regulate the output voltage observed by the OFB pin. This loop is shown in detail in Figure 21.

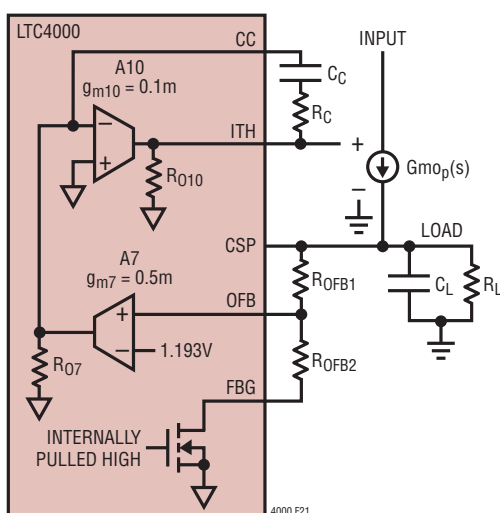

Figure 21. Simplified Linear Model of the Output Voltage Regulation Loop

The simplified loop transmission is as follows:

$$L_{OV}(s) = g_{m7} \left[\frac{\left(R_C - \frac{1}{g_{m10}} \right) C_C s + 1}{C_C s} \right] \cdot \left[\frac{R_{OFB2}}{R_{OFB}} \right] \cdot \left[\frac{R_L}{R_L \cdot C_L s + 1} \right] \cdot G_{mOp}(s)$$

where $G_{mOp}(s)$ is the transfer function from V_{ITH} to the output current of the external DC/DC converter, and $R_{OFB} = R_{OFB1} + R_{OFB2}$.

The Battery Float Voltage Regulation Loop

The battery float voltage regulation loop is very similar to the output float voltage regulation loop. Instead of observing the voltage at the OFB pin, the battery float voltage regulation loop observes the voltage at the BFB pin.

One significant difference is that while the value of R_L in the output voltage loop can vary significantly, the output resistance of the battery float voltage loop is a small constant value approximately equal to the sum of the on-resistance of the external PFET ($R_{DS(ON)}$) and the series internal resistance of the battery (R_{BAT}). This approximation is valid for any efficient system such that most of the output power from the battery is delivered to the system load and not dissipated on the battery internal resistance or the charging PFET on-resistance. For a typical system, minimum R_L is at least five times larger than $R_{DS(ON)} + R_{BAT}$ and R_{BFB} is at least 10^6 times larger than R_{BAT} . Figure 22 shows the detail of the battery float voltage regulation loop.

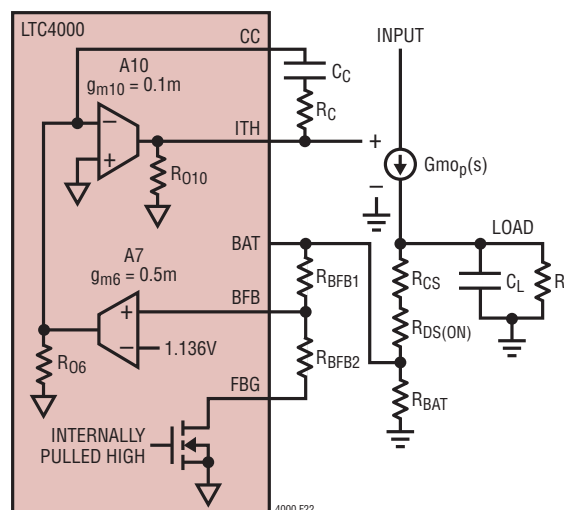

Figure 22. Simplified Linear Model of the Battery Float Voltage Regulation Loop

APPLICATIONS INFORMATION

In Figure 22 the battery is approximated to be a signal ground in series with the internal battery resistance R_{BAT} . Therefore, the simplified loop transmission is as follows:

$$L_{BV}(s) = g_{m6} \left[\frac{\left(R_C - \frac{1}{g_{m10}} \right) C_C s + 1}{C_C s} \right] \cdot \left[\frac{R_{BFB2}}{R_{BFB}} \right] \cdot \left[\frac{R_{LB}}{R_{LB} \cdot C_L s + 1} \right] \cdot G_{mop}(s)$$

where $G_{mop}(s)$ is the transfer function from V_{ITH} to the output current of the external DC/DC converter, $R_{BFB} = R_{BFB1} + R_{BFB2}$, and $R_{LB} = R_L // (R_{DS(ON)} + R_{CS} + R_{BAT})$ represents the effective output resistance from the LOAD node to GND.

The Battery Charge Current Regulation Loop

This final regulation loop combines certain dynamic characteristics that are found in all the other three loops. The feedback signal for this charge current regulation loop is the sense voltage across the charge current sense resistor (R_{CS}). This voltage is amplified by a factor of 20 and compared to the voltage on the CL pin by the transconductance error amplifier (A5). In a familiar fashion, this amplifier drives the output transconductance amplifier (A10) to appropriately adjust the voltage on the ITH pin driving the external DC/DC converter to regulate the input current across the sense resistor (R_{CS}).

Due to the presence of the instant-on feature, description of the charge current regulation loop has to be divided into two separate operating regions. These regions of operation depend on whether the voltage on the OFB pin is higher or lower than the instant-on threshold ($V_{OUT(INST_ON)}$).

The Battery Charge Current Regulation Loop when $V_{OFB} > V_{OUT(INST_ON)}$

In this operating region, the external charging PFET's gate is driven low and clamped at $V_{BGATE(ON)}$. The detail of this loop is shown in Figure 23.

The simplified loop transmission is:

$$L_{CC}(s) = g_{m5} \left[\frac{\left(R_C - \frac{1}{g_{m10}} \right) C_C s + 1}{C_C s} \right] \cdot 20R_{CS} \cdot \left[\frac{(R_2 \cdot C_{IBMON} s + 1)}{(R_1 + R_2) C_{IBMON} s + 1} \right] \cdot \frac{R_L}{R_f + R_L} \cdot \left[\frac{1}{(R_L \parallel R_f) C_L s + 1} \right] \cdot G_{mop}(s)$$

where $G_{mop}(s)$ is the transfer function from V_{ITH} to the output current of the external DC/DC converter, $R_f = R_{CS} + R_{DS(ON)} + R_{BAT}$, and $R_L // R_f$ represents the effective resistance value resulting from the parallel combination of R_L and R_f .

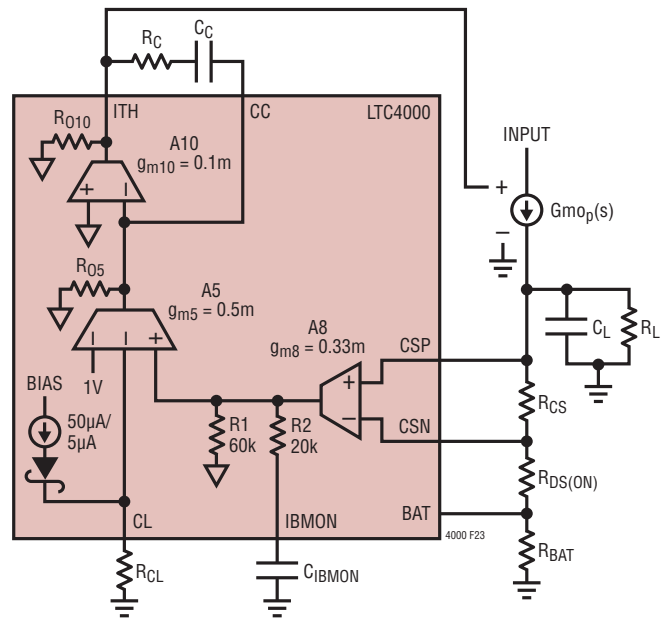

Figure 23. Simplified Linear Model of the Charge Current Regulation Loop with the External Charging PFET Driven On

APPLICATIONS INFORMATION

The Battery Charge Current Regulation Loop when V_{OFB} is Regulated to $V_{OUT(INST_ON)}$

When the battery voltage is below the instant-on level, the external charging PFET is driven linearly to regulate the voltage at the output (connected to the CSP pin). The output voltage is regulated such that the voltage at the OFB pin is equal to the instant-on threshold ($V_{OUT(INST_ON)}$).

If this external PFET regulation is fast compared to the unity crossover frequency of the battery charge current regulation loop, then the voltage at the output can be considered a small signal ground. However, in the LTC4000 the external PFET regulation is purposely made slow to allow for a broader selection of possible PFETs to be used. Therefore, the linear model of the PFET has to be included in the analysis of the charge current regulation loop. The detail of this loop is shown in Figure 24.

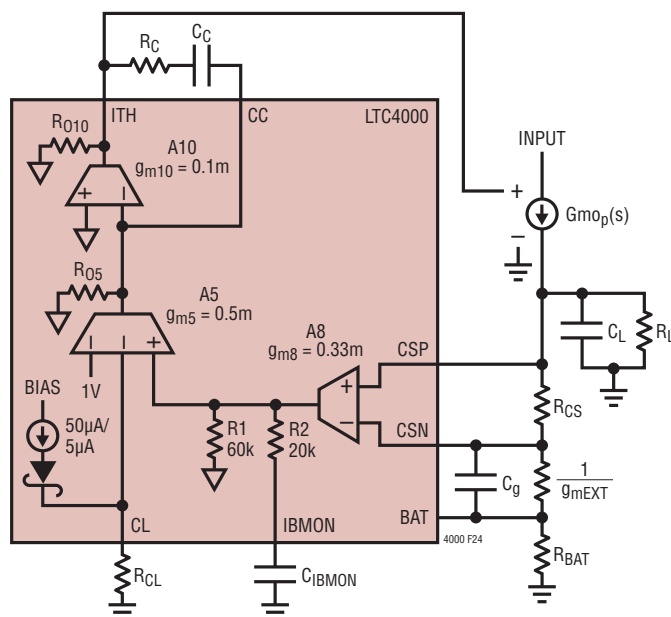

Figure 24. Simplified Linear Model of the Charge Current Regulation Loop with the External Charging PFET Linearly Regulated

The simplified loop transmission is:

$$L_{CC2}(s) = g_{m5} \left[\frac{\left(R_C - \frac{1}{g_{m10}} \right) C_C s + 1}{C_C s} \right] \cdot 20R_{CS} \cdot \left[\frac{(R_2 \cdot C_{IBMON} s + 1)}{(R_1 + R_2) C_{IBMON} s + 1} \right] \cdot \frac{R_L}{R_{fIDC} + R_L} \cdot \left[\frac{1}{(R_L \parallel R_{fIDC}) C_L s + 1} \right] \cdot \left[\frac{\frac{C_g}{g_{mEXT}} s + 1}{\left(\frac{R_{CS} + R_{BAT}}{R_{fIDC}} \right) \frac{C_g}{g_{mEXT}} s + 1} \right] \cdot G_{mOp}(s)$$

where $G_{mOp}(s)$ is the transfer function from V_{ITH} to the output current of the external DC/DC converter, g_{mEXT} is the small signal transconductance of the output PFET, $R_{fIDC} = R_{CS} + 1/g_{mEXT} + R_{BAT}$ and R_L/R_{fIDC} represents the effective resistance value resulting from the parallel combination of R_L and R_{fIDC} .

TYPICAL APPLICATIONS

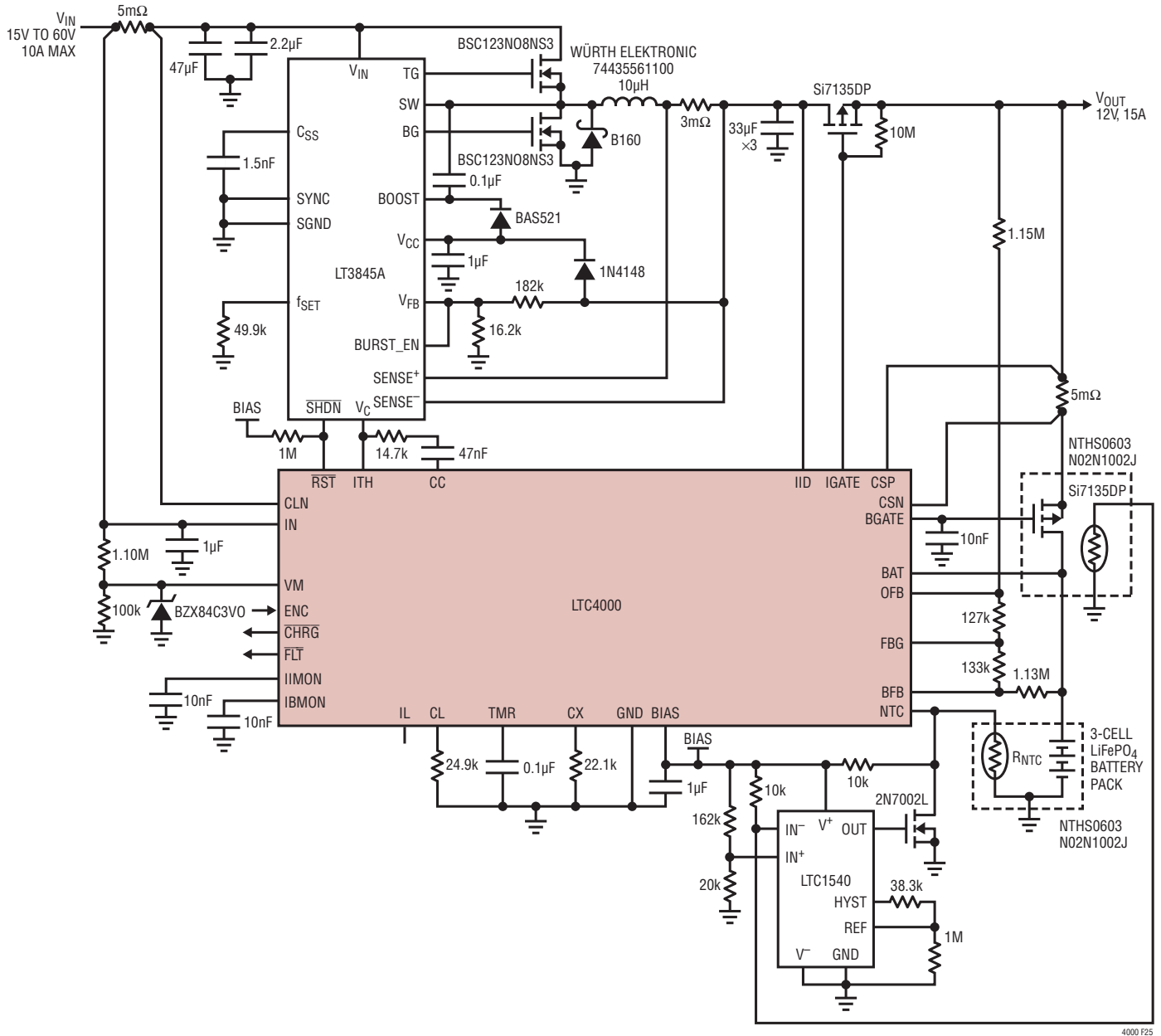

Figure 25. 48V to 10.8V at 10A Buck Converter 3-Cell LiFePO₄ Battery Charger with 2.9h Termination Timer, 1.25A Trickle Charge Current and Charging PFET Thermal Protection

TYPICAL APPLICATIONS

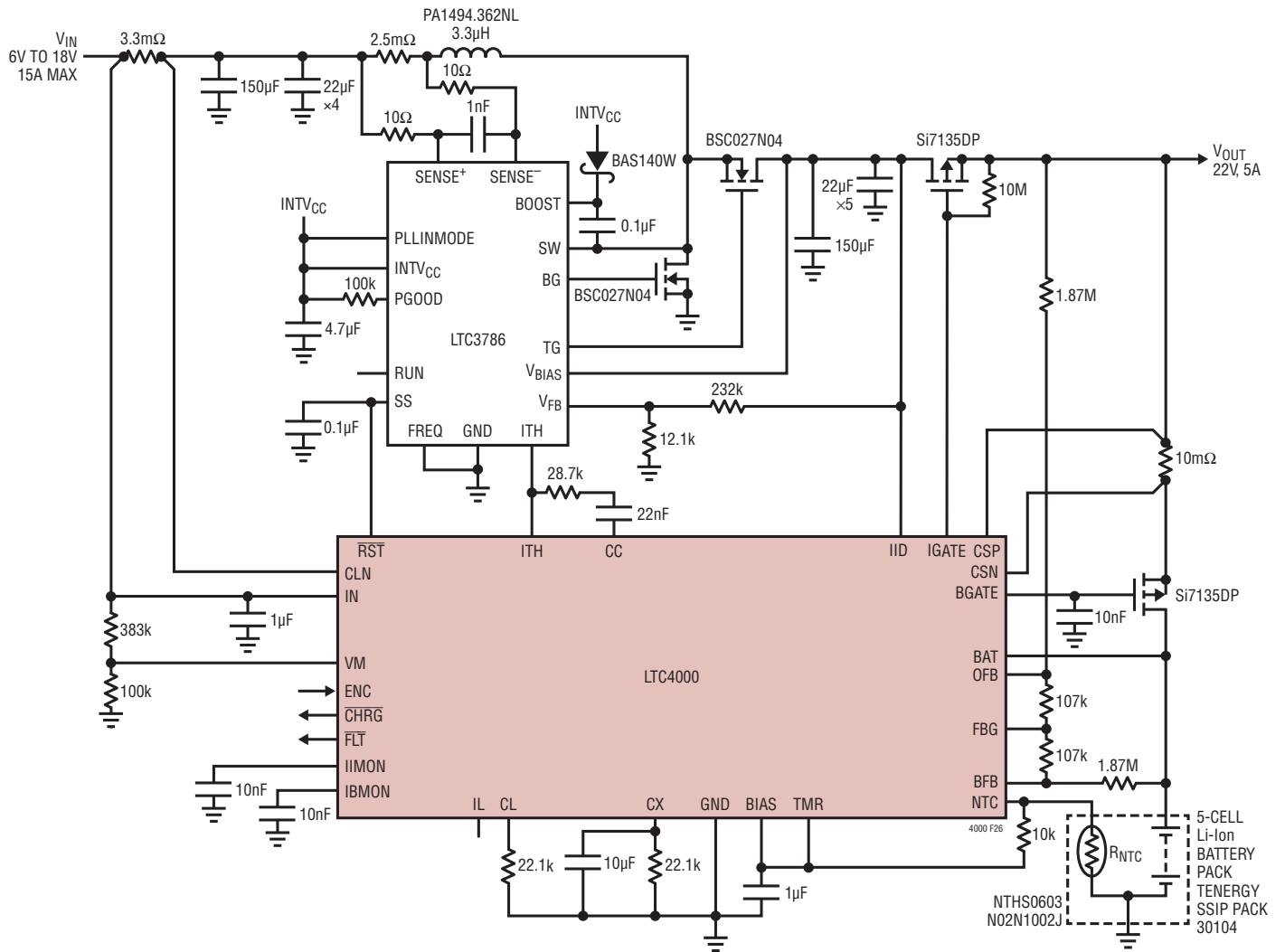

Figure 26. 6V to 21V at 5A Boost Converter 5-Cell Li-Ion Battery Charger with C/10 Termination and 0.55A Trickle Charge Current

TYPICAL APPLICATIONS

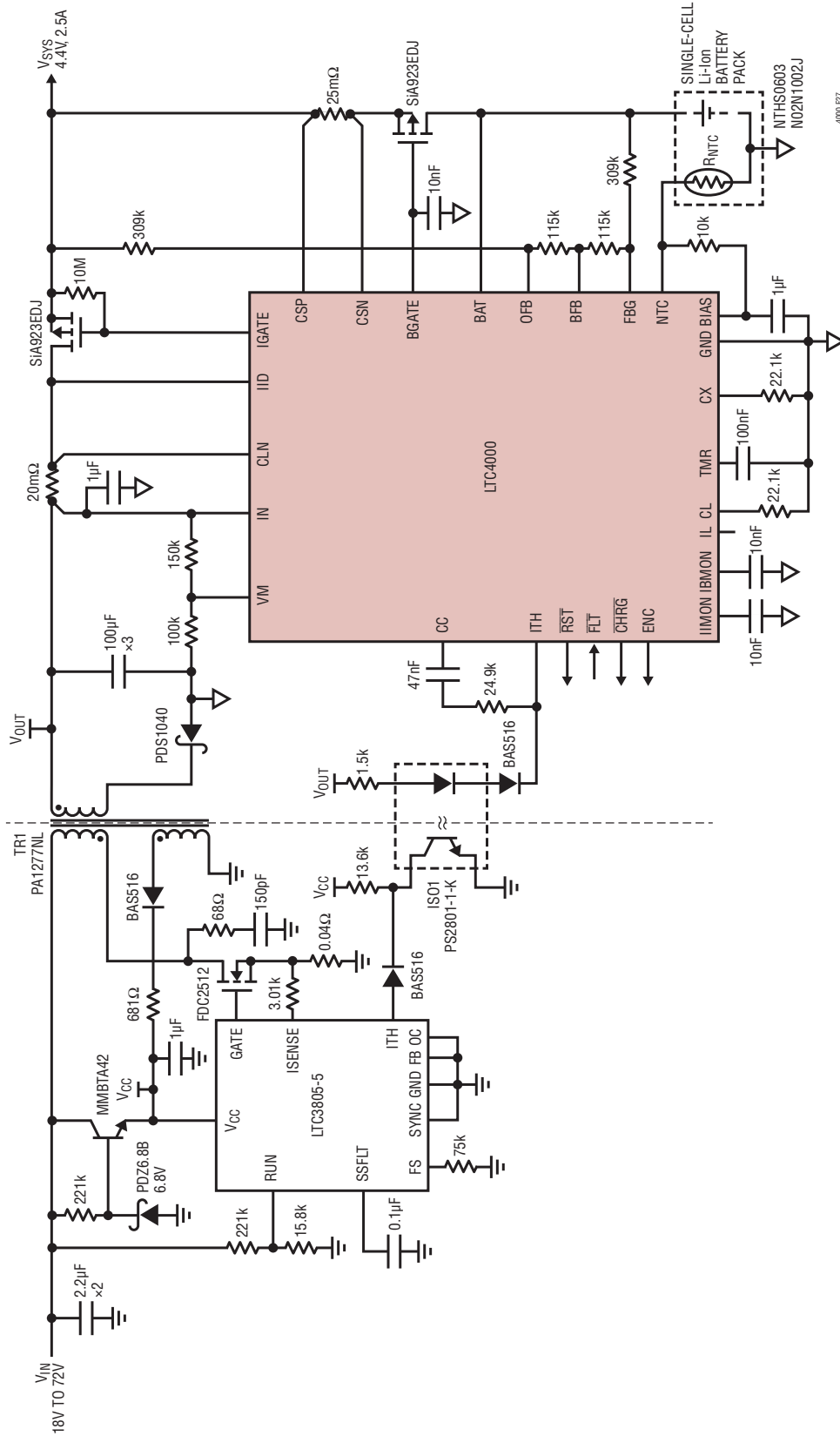

Figure 27. 18V to 72V_{IN} to 4.2V at 2.0A Isolated Flyback Single-Cell Li-ion Battery Charger with 2.9n Timer Termination and 0.22A Trickle Charge Current

4000 F27

PACKAGE DESCRIPTION

Please refer to <http://www.linear.com/designtools/packaging/> for the most recent package drawings.

UFD Package
28-Lead Plastic QFN (4mm × 5mm)
 (Reference LTC DWG # 05-08-1712 Rev B)

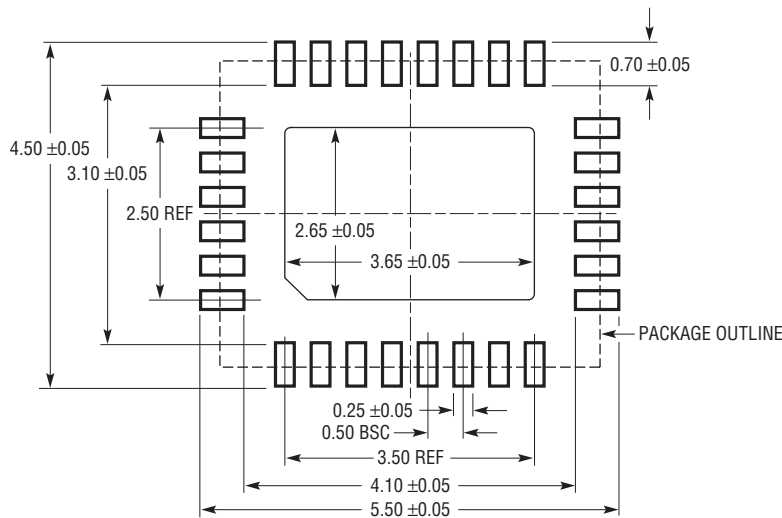

RECOMMENDED SOLDER PAD PITCH AND DIMENSIONS
 APPLY SOLDER MASK TO AREAS THAT ARE NOT SOLDERED

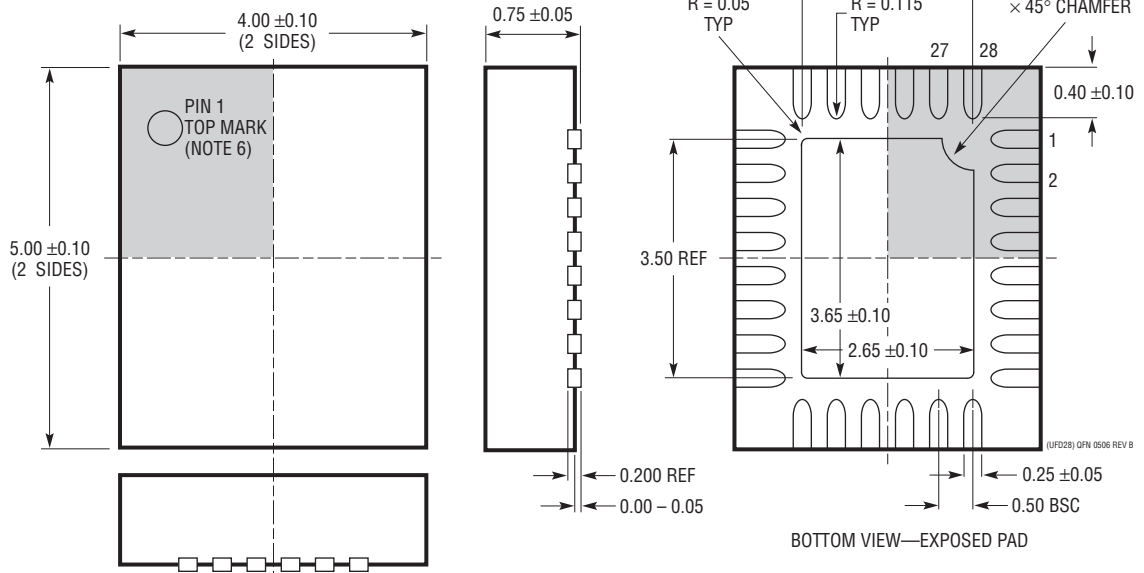

- NOTE:
1. DRAWING PROPOSED TO BE MADE A JEDEC PACKAGE OUTLINE MO-220 VARIATION (WXXX-X).
 2. DRAWING NOT TO SCALE
 3. ALL DIMENSIONS ARE IN MILLIMETERS
 4. DIMENSIONS OF EXPOSED PAD ON BOTTOM OF PACKAGE DO NOT INCLUDE MOLD FLASH. MOLD FLASH, IF PRESENT, SHALL NOT EXCEED 0.15mm ON ANY SIDE
 5. EXPOSED PAD SHALL BE SOLDER PLATED
 6. SHADED AREA IS ONLY A REFERENCE FOR PIN 1 LOCATION ON THE TOP AND BOTTOM OF PACKAGE

PACKAGE DESCRIPTION

Please refer to <http://www.linear.com/designtools/packaging/> for the most recent package drawings.

GN Package 28-Lead Plastic SSOP (Narrow .150 Inch) (Reference LTC DWG # 05-08-1641 Rev B)

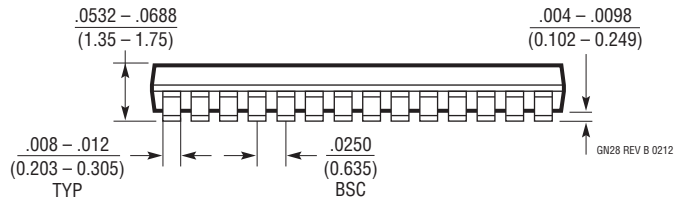
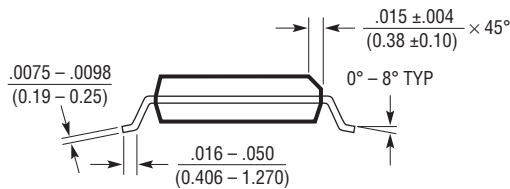
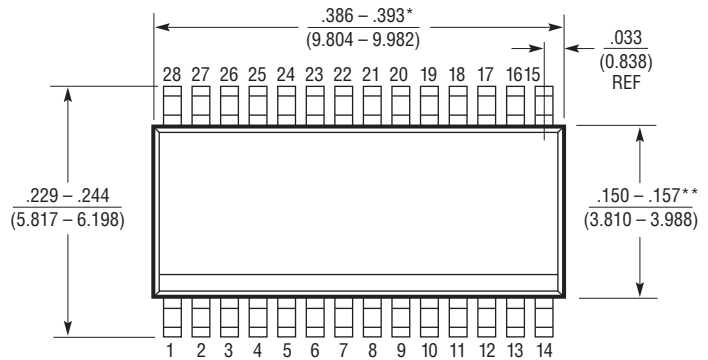
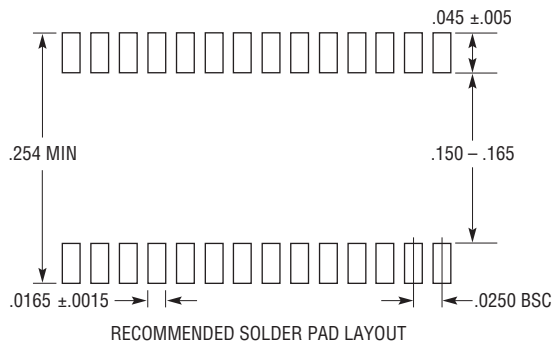

- NOTE:
1. CONTROLLING DIMENSION: INCHES
 2. DIMENSIONS ARE IN $\frac{\text{INCHES}}{\text{MILLIMETERS}}$
 3. DRAWING NOT TO SCALE
 4. PIN 1 CAN BE BEVEL EDGE OR A DIMPLE

*DIMENSION DOES NOT INCLUDE MOLD FLASH. MOLD FLASH SHALL NOT EXCEED 0.006" (0.152mm) PER SIDE
 **DIMENSION DOES NOT INCLUDE INTERLEAD FLASH. INTERLEAD FLASH SHALL NOT EXCEED 0.010" (0.254mm) PER SIDE

REVISION HISTORY

REV	DATE	DESCRIPTION	PAGE NUMBER
A	5/11	Updated the Typical Application.	1
		Updated the Electrical Characteristics section.	3, 4, 5
		Updated the ENC pin text in the Pin Functions section.	8
		Updated the Block Diagram.	11
		Updated Figures 14 and 25.	26, 34
B	6/13	Added Common Mode Range spec to CLN, CSP and CSN.	3
		Revised Ratio of Monitored-Current Voltage to Sense Voltage min	3
		Revised V_{BFB_REG} Battery Feedback Voltage min.	3
		Revised V_{OFB_REG} Output Feedback Voltage min.	3
		Revised Voltage Monitoring Input Falling Threshold min.	4
		Revised IGATE pin functionality.	10
		Revised Input Ideal Diode section.	13
		Revised Input UVLO and Voltage Monitoring section.	15
		Revised Input Ideal Diode PMOS Selection.	16
		Revised R_{CX} C/X detection equation.	18
		Revised Typical Application circuits (resistors).	11, 26, 34 to 36, 40