

FEATURES

- 500ksps Throughput Rate
- ± 0.5 LSB INL (Max)
- Guaranteed 16-Bit No Missing Codes
- Low Power: 6.8mW at 500ksps, 6.8 μ W at 500sps
- 97dB SNR (Typ) at $f_{IN} = 2$ kHz
- -123dB THD (Typ) at $f_{IN} = 2$ kHz
- Digital Gain Compression (DGC)
- Guaranteed Operation to 125°C
- 2.5V Supply
- Fully Differential Input Range $\pm V_{REF}$
- V_{REF} Input Range from 2.5V to 5.1V
- No Pipeline Delay, No Cycle Latency
- 1.8V to 5V I/O Voltages
- SPI-Compatible Serial I/O with Daisy-Chain Mode
- Internal Conversion Clock
- 16-Lead MSOP and 4mm \times 3mm DFN Packages

APPLICATIONS

- Medical Imaging
- High Speed Data Acquisition
- Portable or Compact Instrumentation
- Industrial Process Control
- Low Power Battery-Operated Instrumentation
- ATE

LT, LT, LTC, LTM, Linear Technology and the Linear logo are registered trademarks and SoftSpan is a trademark of Linear Technology Corporation. All other trademarks are the property of their respective owners.

DESCRIPTION

The LTC[®]2377-16 is a low noise, low power, high speed 16-bit successive approximation register (SAR) ADC. Operating from a 2.5V supply, the LTC2377-16 has a $\pm V_{REF}$ fully differential input range with V_{REF} ranging from 2.5V to 5.1V. The LTC2377-16 consumes only 6.8mW and achieves ± 0.5 LSB INL maximum, no missing codes at 16 bits with 97dB SNR.

The LTC2377-16 has a high speed SPI-compatible serial interface that supports 1.8V, 2.5V, 3.3V and 5V logic while also featuring a daisy-chain mode. The fast 500ksps throughput with no cycle latency makes the LTC2377-16 ideally suited for a wide variety of high speed applications. An internal oscillator sets the conversion time, easing external timing considerations. The LTC2377-16 automatically powers down between conversions, leading to reduced power dissipation that scales with the sampling rate.

The LTC2377-16 features a unique digital gain compression (DGC) function, which eliminates the driver amplifier's negative supply while preserving the full resolution of the ADC. When enabled, the ADC performs a digital scaling function that maps zero-scale code from 0V to $0.1 \cdot V_{REF}$ and full-scale code from V_{REF} to $0.9 \cdot V_{REF}$. For a typical reference voltage of 5V, the full-scale input range is now 0.5V to 4.5V, which provides adequate headroom for powering the driving amplifier from a single 5.5V supply.

TYPICAL APPLICATION

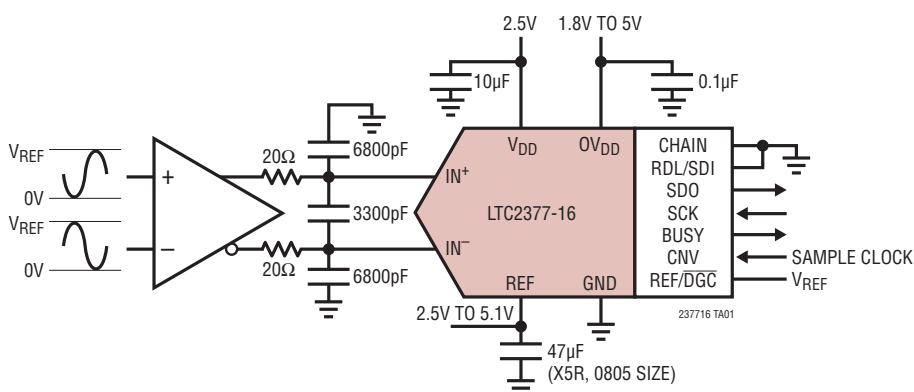

32k Point FFT $f_s = 500$ ksps, $f_{IN} = 2$ kHz

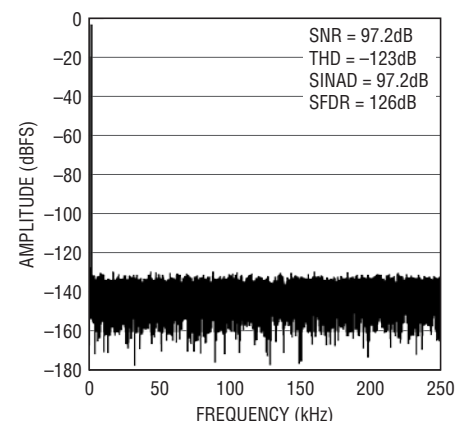

237716 TA02
237716fa

LTC2377-16

ABSOLUTE MAXIMUM RATINGS

(Notes 1, 2)

Supply Voltage (V_{DD})	2.8V	Digital Output Voltage	
Supply Voltage (OV_{DD})	6V	(Note 3)	(GND - 0.3V) to ($OV_{DD} + 0.3V$)
Reference Input (REF)	6V	Power Dissipation	500mW
Analog Input Voltage (Note 3)		Operating Temperature Range	
IN^+ , IN^-	(GND - 0.3V) to (REF + 0.3V)	LTC2377C	0°C to 70°C
REF/DGC Input (Note 3)	(GND - 0.3V) to (REF + 0.3V)	LTC2377I	-40°C to 85°C
Digital Input Voltage		LTC2377H	-40°C to 125°C
(Note 3)	(GND - 0.3V) to ($OV_{DD} + 0.3V$)	Storage Temperature Range	-65°C to 150°C

PIN CONFIGURATION

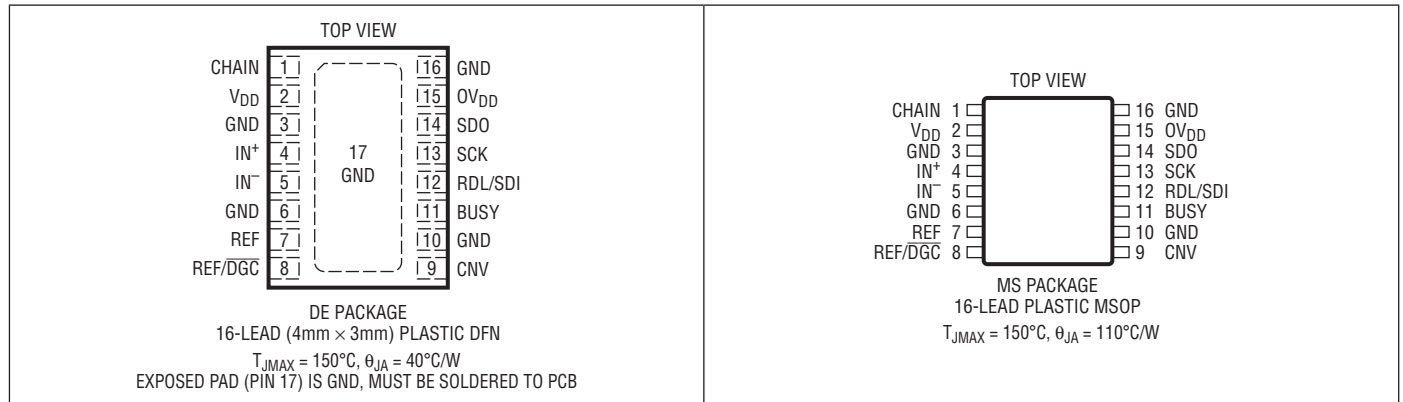

ORDER INFORMATION <http://www.linear.com/product/LTC2377-16#orderinfo>

LEAD FREE FINISH	TAPE AND REEL	PART MARKING*	PACKAGE DESCRIPTION	TEMPERATURE RANGE
LTC2377CMS-16#PBF	LTC2377CMS-16#TRPBF	237716	16-Lead Plastic MSOP	0°C to 70°C
LTC2377IMS-16#PBF	LTC2377IMS-16#TRPBF	237716	16-Lead Plastic MSOP	-40°C to 85°C
LTC2377HMS-16#PBF	LTC2377HMS-16#TRPBF	237716	16-Lead Plastic MSOP	-40°C to 125°C
LTC2377CDE-16#PBF	LTC2377CDE-16#TRPBF	23776	16-Lead (4mm × 3mm) Plastic DFN	0°C to 70°C
LTC2377IDE-16#PBF	LTC2377IDE-16#TRPBF	23776	16-Lead (4mm × 3mm) Plastic DFN	-40°C to 85°C

Consult LTC Marketing for parts specified with wider operating temperature ranges. *The temperature grade is identified by a label on the shipping container. Consult LTC Marketing for information on non-standard lead based finish parts.

For more information on lead free part marking, go to: <http://www.linear.com/leadfree/>

For more information on tape and reel specifications, go to: <http://www.linear.com/tapeandree/>. Some packages are available in 500 unit reels through designated sales channels with #TRMPBF suffix.

ELECTRICAL CHARACTERISTICS

The ● denotes the specifications which apply over the full operating temperature range, otherwise specifications are at $T_A = 25^\circ\text{C}$. (Note 4)

SYMBOL	PARAMETER	CONDITIONS	MIN	TYP	MAX	UNITS
V_{IN+}	Absolute Input Range (IN^+)	(Note 5)	●	-0.05	$V_{REF} + 0.05$	V
V_{IN-}	Absolute Input Range (IN^-)	(Note 5)	●	-0.05	$V_{REF} + 0.05$	V
$V_{IN+} - V_{IN-}$	Input Differential Voltage Range	$V_{IN} = V_{IN+} - V_{IN-}$	●	$-V_{REF}$	$+V_{REF}$	V
V_{CM}	Common-Mode Input Range		●	$V_{REF}/2 - 0.1$	$V_{REF}/2 + 0.1$	V
I_{IN}	Analog Input Leakage Current		●		± 1	μA
C_{IN}	Analog Input Capacitance	Sample Mode Hold Mode		45 5		pF pF
CMRR	Input Common Mode Rejection Ratio	$f_{IN} = 250\text{kHz}$		86		dB

CONVERTER CHARACTERISTICS

The ● denotes the specifications which apply over the full operating temperature range, otherwise specifications are at $T_A = 25^\circ\text{C}$. (Note 4)

SYMBOL	PARAMETER	CONDITIONS	MIN	TYP	MAX	UNITS
	Resolution		●	16		Bits
	No Missing Codes		●	16		Bits
	Transition Noise			0.15		LSB_{RMS}
INL	Integral Linearity Error	(Note 6)	●	-0.5	± 0.2	0.5 LSB
DNL	Differential Linearity Error		●	-0.5	± 0.1	0.5 LSB
BZE	Bipolar Zero-Scale Error	(Note 7)	●	-4	0	4 LSB
	Bipolar Zero-Scale Error Drift			1		$\text{mLSB}/^\circ\text{C}$
FSE	Bipolar Full-Scale Error	(Note 7)	●	-13	± 2	13 LSB
	Bipolar Full-Scale Error Drift			± 0.05		$\text{ppm}/^\circ\text{C}$

DYNAMIC ACCURACY

The ● denotes the specifications which apply over the full operating temperature range, otherwise specifications are at $T_A = 25^\circ\text{C}$ and $A_{IN} = -1\text{dBFS}$. (Notes 4, 8)

SYMBOL	PARAMETER	CONDITIONS	MIN	TYP	MAX	UNITS
SINAD	Signal-to-(Noise + Distortion) Ratio	$f_{IN} = 2\text{kHz}, V_{REF} = 5\text{V}$	●	94.6	97	dB
		$f_{IN} = 2\text{kHz}, V_{REF} = 5\text{V}, (\text{H-Grade})$	●	94.5	97	dB
SNR	Signal-to-Noise Ratio	$f_{IN} = 2\text{kHz}, V_{REF} = 5\text{V}$	●	95.3	97	dB
		$f_{IN} = 2\text{kHz}, V_{REF} = 5\text{V}, \text{REF}/\overline{\text{DGC}} = \text{GND}$	●	94.5	96.4	dB
		$f_{IN} = 2\text{kHz}, V_{REF} = 2.5\text{V}$	●	92.1	95	dB
		$f_{IN} = 2\text{kHz}, V_{REF} = 5\text{V}, (\text{H-Grade})$	●	95.2	97	dB
		$f_{IN} = 2\text{kHz}, V_{REF} = 5\text{V}, \text{REF}/\overline{\text{DGC}} = \text{GND}, (\text{H-Grade})$	●	94.3	96.4	dB
		$f_{IN} = 2\text{kHz}, V_{REF} = 2.5\text{V}, (\text{H-Grade})$	●	91.8	95	dB
THD	Total Harmonic Distortion	$f_{IN} = 2\text{kHz}, V_{REF} = 5\text{V}$	●	-123	-103	dB
		$f_{IN} = 2\text{kHz}, V_{REF} = 5\text{V}, \text{REF}/\overline{\text{DGC}} = \text{GND}$	●	-125	-101	dB
		$f_{IN} = 2\text{kHz}, V_{REF} = 2.5\text{V}$	●	-122	-103	dB
SFDR	Spurious Free Dynamic Range	$f_{IN} = 2\text{kHz}, V_{REF} = 5\text{V}$	●	104	124	dB
		-3dB Input Bandwidth			34	MHz
	Aperture Delay			500	ps	
	Aperture Jitter			4	ps	
	Transient Response	Full-Scale Step			1.46	μs

REFERENCE INPUT

The ● denotes the specifications which apply over the full operating temperature range, otherwise specifications are at $T_A = 25^\circ\text{C}$. (Note 4)

SYMBOL	PARAMETER	CONDITIONS	MIN	TYP	MAX	UNITS
V_{REF}	Reference Voltage	(Note 5)	● 2.5		5.1	V
I_{REF}	Reference Input Current	(Note 9)	●	0.32	0.4	mA
$V_{IH\overline{DGC}}$	High Level Input Voltage REF/ \overline{DGC} Pin		● $0.8V_{REF}$			V
$V_{IL\overline{DGC}}$	Low Level Input Voltage REF/ \overline{DGC} Pin		●		$0.2V_{REF}$	V

DIGITAL INPUTS AND DIGITAL OUTPUTS

The ● denotes the specifications which apply over the full operating temperature range, otherwise specifications are at $T_A = 25^\circ\text{C}$. (Note 4)

SYMBOL	PARAMETER	CONDITIONS	MIN	TYP	MAX	UNITS
V_{IH}	High Level Input Voltage		● $0.8 \cdot OV_{DD}$			V
V_{IL}	Low Level Input Voltage		●		$0.2 \cdot OV_{DD}$	V
I_{IN}	Digital Input Current	$V_{IN} = 0V$ to OV_{DD}	● -10		10	μA
C_{IN}	Digital Input Capacitance			5		pF
V_{OH}	High Level Output Voltage	$I_O = -500\mu\text{A}$	● $OV_{DD} - 0.2$			V
V_{OL}	Low Level Output Voltage	$I_O = 500\mu\text{A}$	●		0.2	V
I_{OZ}	Hi-Z Output Leakage Current	$V_{OUT} = 0V$ to OV_{DD}	● -10		10	μA
I_{SOURCE}	Output Source Current	$V_{OUT} = 0V$		-10		mA
I_{SINK}	Output Sink Current	$V_{OUT} = OV_{DD}$		10		mA

POWER REQUIREMENTS

The ● denotes the specifications which apply over the full operating temperature range, otherwise specifications are at $T_A = 25^\circ\text{C}$. (Note 4)

SYMBOL	PARAMETER	CONDITIONS	MIN	TYP	MAX	UNITS
V_{DD}	Supply Voltage		● 2.375	2.5	2.625	V
OV_{DD}	Supply Voltage		● 1.71		5.25	V
I_{VDD}	Supply Current	500ksps Sample Rate	●	2.7	3.2	mA
I_{OVDD}	Supply Current	500ksps Sample Rate ($C_L = 20\text{pF}$)	●	0.1		mA
I_{PD}	Power Down Mode	Conversion Done ($I_{VDD} + I_{OVDD} + I_{REF}$)	●	0.9	90	μA
I_{PD}	Power Down Mode	Conversion Done ($I_{VDD} + I_{OVDD} + I_{REF}$, H-Grade)	●	0.9	140	μA
P_D	Power Dissipation	500ksps Sample Rate		6.75	8	mW
	Power Down Mode	Conversion Done ($I_{VDD} + I_{OVDD} + I_{REF}$)		2.25	225	μW
	Power Down Mode	Conversion Done ($I_{VDD} + I_{OVDD} + I_{REF}$, H-Grade)		2.25	315	μW

ADC TIMING CHARACTERISTICS

The ● denotes the specifications which apply over the full operating temperature range, otherwise specifications are at $T_A = 25^\circ\text{C}$. (Note 4)

SYMBOL	PARAMETER	CONDITIONS	MIN	TYP	MAX	UNITS
f_{SAMPL}	Maximum Sampling Frequency		●		500	ksps
t_{CONV}	Conversion Time		● 1		1.5	μs
t_{ACQ}	Acquisition Time	$t_{ACQ} = t_{CYC} - t_{HOLD}$ (Note 10)	● 1.46			μs
t_{HOLD}	Maximum Time Between Acquisitions		●		540	ns
t_{CYC}	Time Between Conversions		● 2			μs
t_{CNVH}	CNV High Time		● 20			ns
t_{BUSYLH}	CNV \uparrow to BUSY Delay	$C_L = 20\text{pF}$	●		13	ns
t_{CNVL}	Minimum Low Time for CNV	(Note 11)	● 20			ns
t_{QUIET}	SCK Quiet Time from CNV \uparrow	(Note 10)	● 20			ns

237716fa

ADC TIMING CHARACTERISTICS

The ● denotes the specifications which apply over the full operating temperature range, otherwise specifications are at $T_A = 25^\circ\text{C}$. (Note 4)

SYMBOL	PARAMETER	CONDITIONS	MIN	TYP	MAX	UNITS
t_{SCK}	SCK Period	(Notes 11, 12)	●	10		ns
t_{SCKH}	SCK High Time		●	4		ns
t_{SCKL}	SCK Low Time		●	4		ns
t_{SSDISCK}	SDI Setup Time From SCK↑	(Note 11)	●	4		ns
t_{HSDISCK}	SDI Hold Time From SCK↑	(Note 11)	●	1		ns
t_{SCKCH}	SCK Period in Chain Mode	$t_{\text{SCKCH}} = t_{\text{SSDISCK}} + t_{\text{DSDO}}$ (Note 11)	●	13.5		ns
t_{DSDO}	SDO Data Valid Delay from SCK↑	$C_L = 20\text{pF}$ (Note 11)	●		9.5	ns
t_{HSDO}	SDO Data Remains Valid Delay from SCK↑	$C_L = 20\text{pF}$ (Note 10)	●	1		ns
$t_{\text{DSDOBUSYL}}$	SDO Data Valid Delay from BUSY↓	$C_L = 20\text{pF}$ (Note 10)	●		5	ns
t_{EN}	Bus Enable Time After RDL↓	(Note 11)	●		16	ns
t_{DIS}	Bus Relinquish Time After RDL↑	(Note 11)	●		13	ns

Note 1: Stresses beyond those listed under Absolute Maximum Ratings may cause permanent damage to the device. Exposure to any Absolute Maximum Rating condition for extended periods may effect device reliability and lifetime.

Note 2: All voltage values are with respect to ground.

Note 3: When these pin voltages are taken below ground or above REF or OV_{DD} , they will be clamped by internal diodes. This product can handle input currents up to 100mA below ground or above REF or OV_{DD} without latch-up.

Note 4: $V_{\text{DD}} = 2.5\text{V}$, $\text{OV}_{\text{DD}} = 2.5\text{V}$, $\text{REF} = 5\text{V}$, $V_{\text{CM}} = 2.5\text{V}$, $f_{\text{SAMPL}} = 500\text{kHz}$, $\text{REF}/\text{DGC} = V_{\text{REF}}$.

Note 5: Recommended operating conditions.

Note 6: Integral nonlinearity is defined as the deviation of a code from a straight line passing through the actual endpoints of the transfer curve. The deviation is measured from the center of the quantization band.

Note 7: Bipolar zero-scale error is the offset voltage measured from -0.5LSB when the output code flickers between 0000 0000 0000 0000 and 1111 1111 1111 1111. Full-scale bipolar error is the worst-case of $-\text{FS}$ or $+\text{FS}$ untrimmed deviation from ideal first and last code transitions and includes the effect of offset error.

Note 8: All specifications in dB are referred to a full-scale $\pm 5\text{V}$ input with a 5V reference voltage.

Note 9: $f_{\text{SAMPL}} = 500\text{kHz}$, I_{REF} varies proportionately with sample rate.

Note 10: Guaranteed by design, not subject to test.

Note 11: Parameter tested and guaranteed at $\text{OV}_{\text{DD}} = 1.71\text{V}$, $\text{OV}_{\text{DD}} = 2.5\text{V}$ and $\text{OV}_{\text{DD}} = 5.25\text{V}$.

Note 12: t_{SCK} of 10ns maximum allows a shift clock frequency up to 100MHz for rising capture.

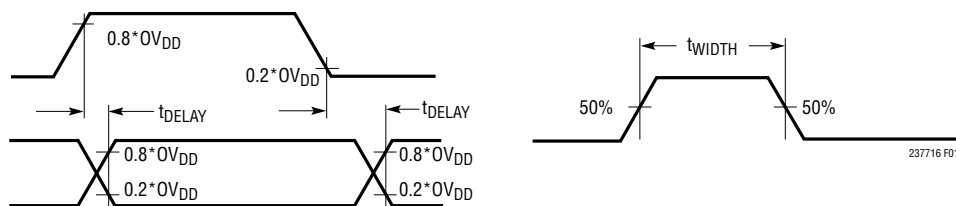
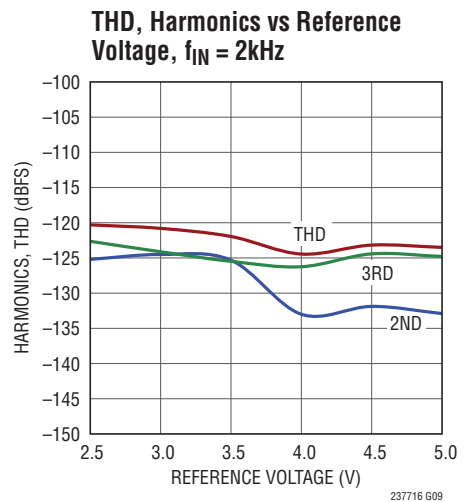
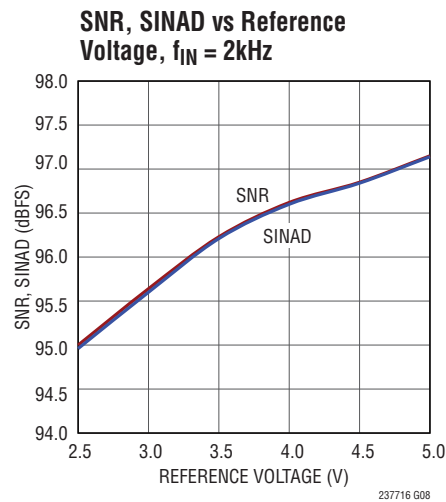
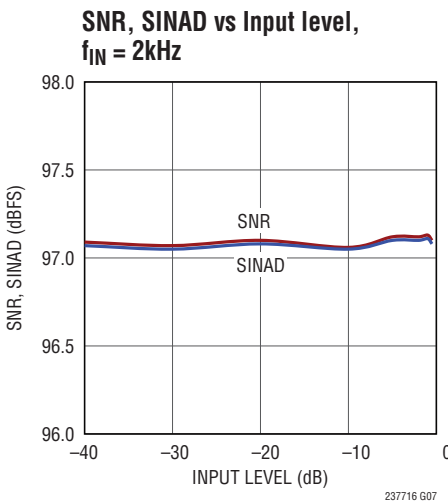
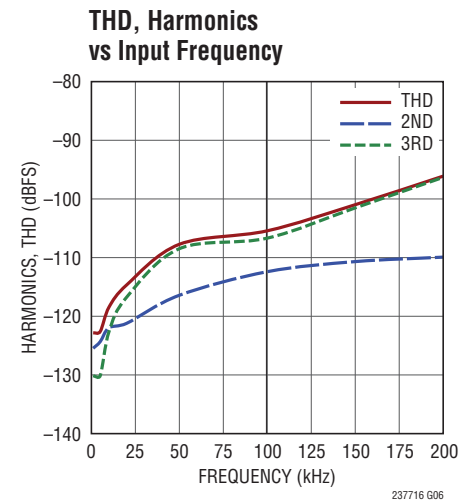
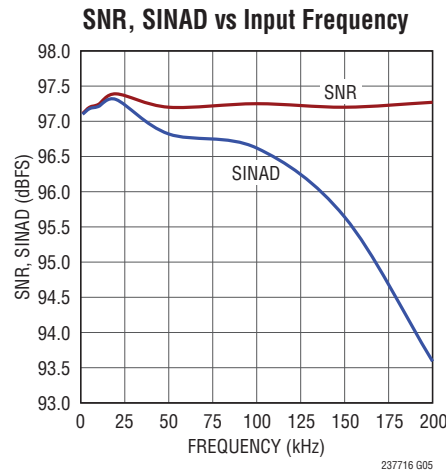
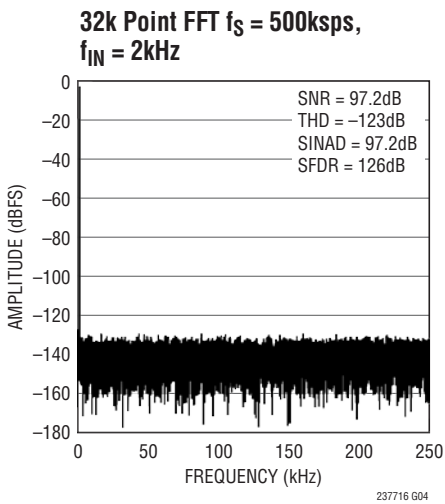
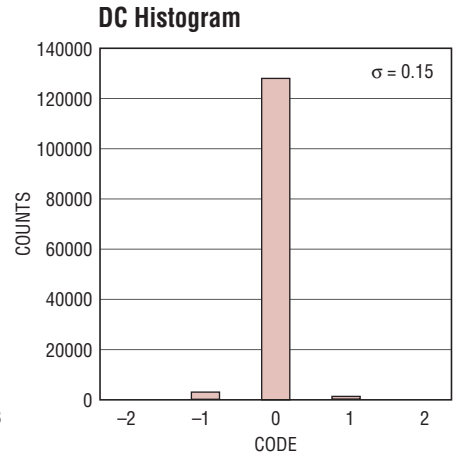
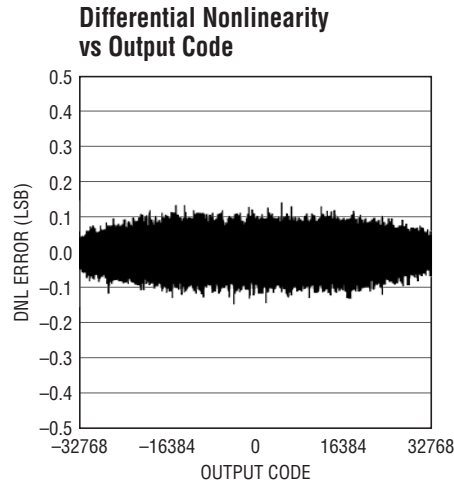
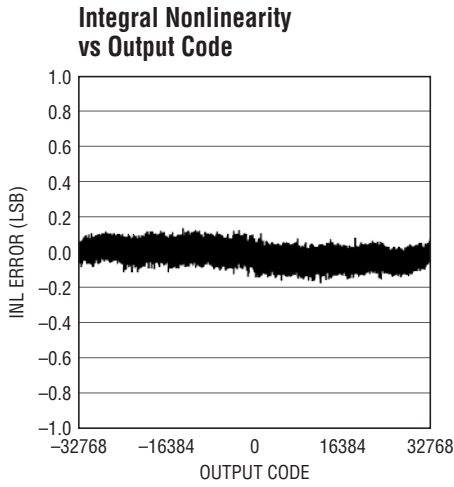

Figure 1. Voltage Levels for Timing Specifications

TYPICAL PERFORMANCE CHARACTERISTICS

REF = 5V, $f_{SAMPL} = 500\text{kps}$, unless otherwise noted.

$T_A = 25^\circ\text{C}$, $V_{DD} = 2.5\text{V}$, $0V_{DD} = 2.5\text{V}$, $V_{CM} = 2.5\text{V}$,



TYPICAL PERFORMANCE CHARACTERISTICS $T_A = 25^\circ\text{C}$, $V_{DD} = 2.5\text{V}$, $OV_{DD} = 2.5\text{V}$, $V_{CM} = 2.5\text{V}$,
 $REF = 5\text{V}$, $f_{SAMPL} = 500\text{ksps}$, unless otherwise noted.

SNR, SINAD vs Temperature,
 $f_{IN} = 2\text{kHz}$

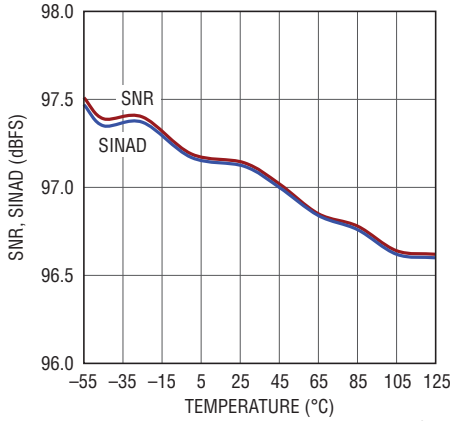

237716 G10

THD, Harmonics vs Temperature,
 $f_{IN} = 2\text{kHz}$

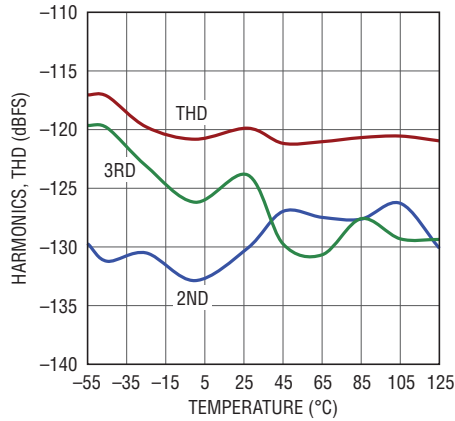

237716 G11

INL/DNL vs Temperature

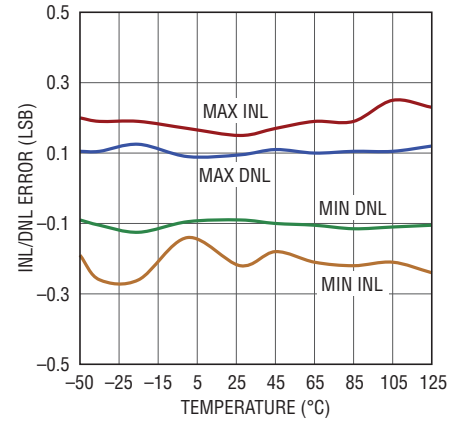

237716 G12

Full-Scale Error vs Temperature

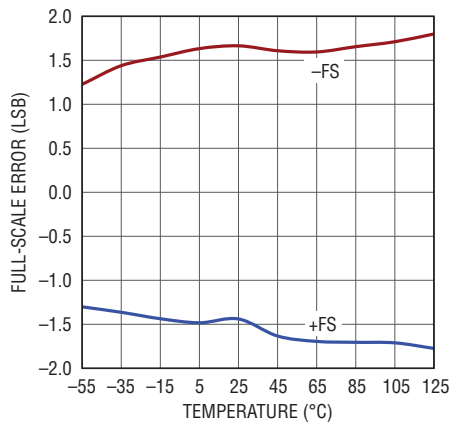

237716 G13

Offset Error vs Temperature

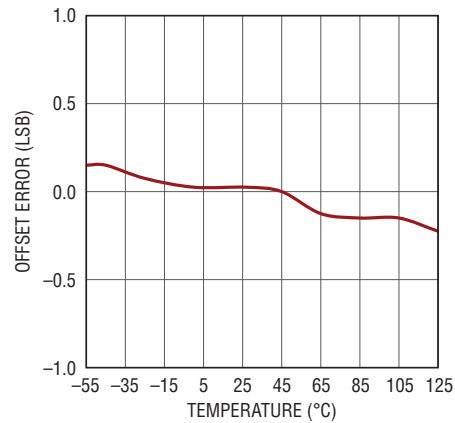

237716 G14

Supply Current vs Temperature

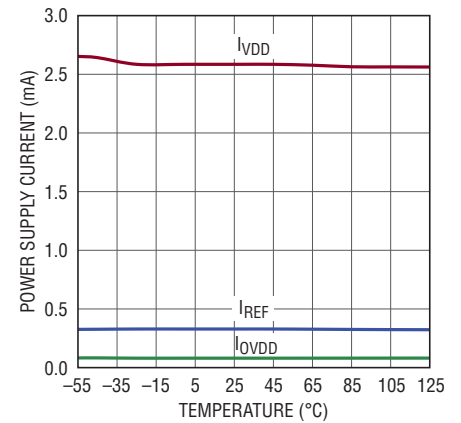

237716 G15

Shutdown Current vs Temperature

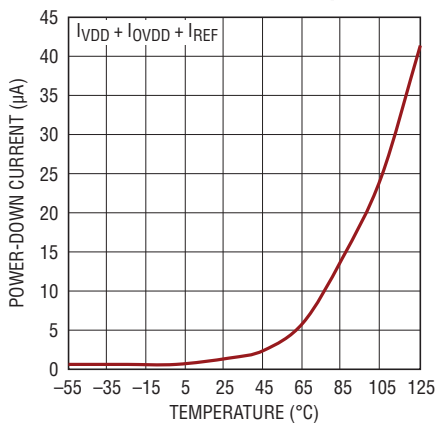

237716 G16

CMRR vs Input Frequency

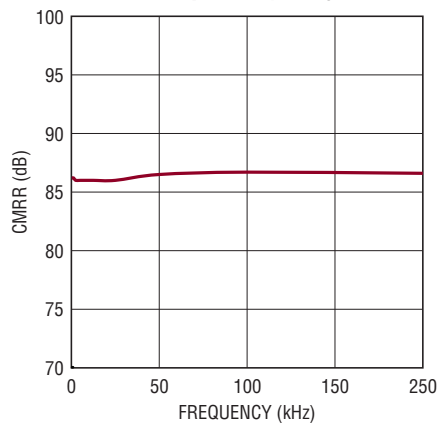

237716 G17

Reference Current vs Reference Voltage

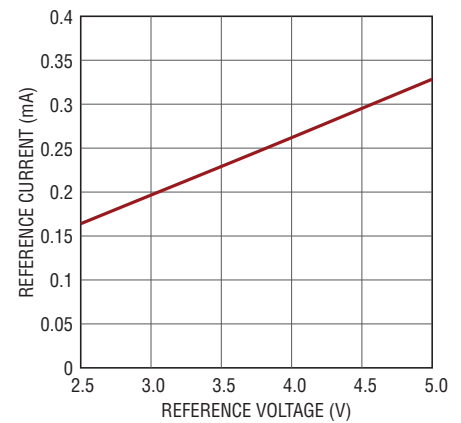

237716 G18

PIN FUNCTIONS

CHAIN (Pin 1): Chain Mode Selector Pin. When low, the LTC2377-16 operates in normal mode and the RDL/SDI input pin functions to enable or disable SDO. When high, the LTC2377-16 operates in chain mode and the RDL/SDI pin functions as SDI, the daisy-chain serial data input. Logic levels are determined by OV_{DD} .

V_{DD} (Pin 2): 2.5V Power Supply. The range of V_{DD} is 2.375V to 2.625V. Bypass V_{DD} to GND with a 10 μ F ceramic capacitor.

GND (Pins 3, 6, 10 and 16): Ground.

IN^+ , IN^- (Pins 4, 5): Positive and Negative Differential Analog Inputs.

REF (Pin 7): Reference Input. The range of REF is 2.5V to 5.1V. This pin is referred to the GND pin and should be decoupled closely to the pin with a 47 μ F ceramic capacitor (X5R, 0805 size).

REF/DGC (Pin 8): When tied to REF, digital gain compression is disabled and the LTC2377-16 defines full-scale according to the $\pm V_{REF}$ analog input range. When tied to GND, digital gain compression is enabled and the LTC2377-16 defines full-scale with inputs that swing between 10% and 90% of the $\pm V_{REF}$ analog input range.

CNV (Pin 9): Convert Input. A rising edge on this input powers up the part and initiates a new conversion. Logic levels are determined by OV_{DD} .

BUSY (Pin 11): BUSY Indicator. Goes high at the start of a new conversion and returns low when the conversion has finished. Logic levels are determined by OV_{DD} .

RDL/SDI (Pin 12): When CHAIN is low, the part is in normal mode and the pin is treated as a bus enabling input. When CHAIN is high, the part is in chain mode and the pin is treated as a serial data input pin where data from another ADC in the daisy-chain is input. Logic levels are determined by OV_{DD} .

SCK (Pin 13): Serial Data Clock Input. When SDO is enabled, the conversion result or daisy-chain data from another ADC is shifted out on the rising edges of this clock MSB first. Logic levels are determined by OV_{DD} .

SDO (Pin 14): Serial Data Output. The conversion result or daisy-chain data is output on this pin on each rising edge of SCK MSB first. The output data is in 2's complement format. Logic levels are determined by OV_{DD} .

OV_{DD} (Pin 15): I/O Interface Digital Power. The range of OV_{DD} is 1.71V to 5.25V. This supply is nominally set to the same supply as the host interface (1.8V, 2.5V, 3.3V, or 5V). Bypass OV_{DD} to GND with a 0.1 μ F capacitor.

GND (Exposed Pad Pin 17 – DFN Package Only): Ground. Exposed pad must be soldered directly to the ground plane.

FUNCTIONAL BLOCK DIAGRAM

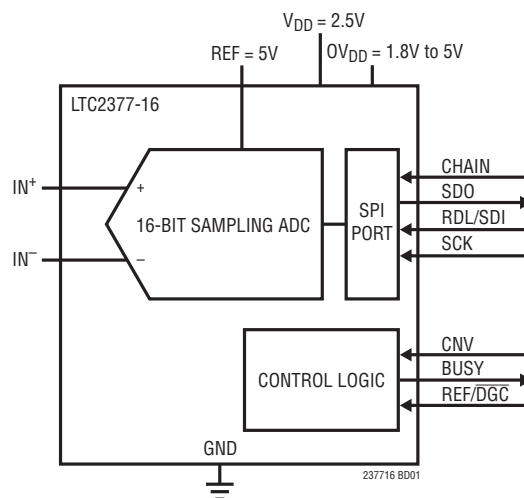

237716fa

TIMING DIAGRAM

Conversion Timing Using the Serial Interface

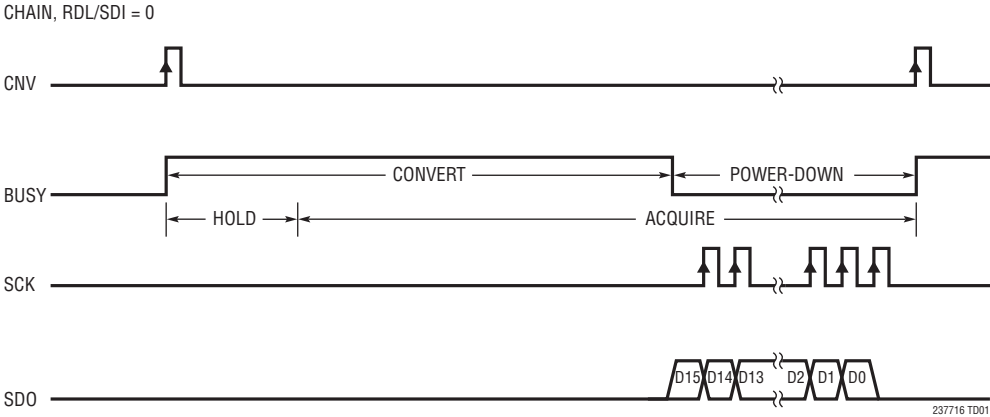

APPLICATIONS INFORMATION

OVERVIEW

The LTC2377-16 is a low noise, low power, high speed 16-Bit successive approximation register (SAR) ADC. Operating from a single 2.5V supply, the LTC2377-16 supports a large and flexible $\pm V_{REF}$ fully differential input range with V_{REF} ranging from 2.5V to 5.1V, making it ideal for high performance applications which require a wide dynamic range. The LTC2377-16 achieves $\pm 0.5\text{LSB}$ INL max, no missing codes at 16 bits and 97dB SNR.

Fast 500ksps throughput with no cycle latency makes the LTC2377-16 ideally suited for a wide variety of high speed applications. An internal oscillator sets the conversion time, easing external timing considerations. The LTC2377-16 dissipates only 6.8mW at 500ksps, while an auto power-down feature is provided to further reduce power dissipation during inactive periods.

The LTC2377-16 features a unique digital gain compression (DGC) function, which eliminates the driver amplifier's negative supply while preserving the full resolution of the ADC. When enabled, the ADC performs a digital scaling function that maps zero-scale code from 0V to $0.1 \cdot V_{REF}$ and full-scale code from V_{REF} to $0.9 \cdot V_{REF}$. For a typical reference voltage of 5V, the full-scale input range is now 0.5V to 4.5V, which provides adequate headroom for powering the driving amplifier from a single 5.5V supply.

CONVERTER OPERATION

The LTC2377-16 operates in two phases. During the acquisition phase, the charge redistribution capacitor D/A converter (CDAC) is connected to the IN^+ and IN^- pins to sample the differential analog input voltage. A rising edge on the CNV pin initiates a conversion. During the conversion phase, the 16-bit CDAC is sequenced through a successive approximation algorithm, effectively comparing the sampled input with binary-weighted fractions of the reference voltage (e.g. $V_{REF}/2$, $V_{REF}/4 \dots V_{REF}/65536$) using the differential comparator. At the end of conversion, the CDAC output approximates the sampled analog input. The ADC control logic then prepares the 16-bit digital output code for serial transfer.

TRANSFER FUNCTION

The LTC2377-16 digitizes the full-scale voltage of $2 \times REF$ into 2^{16} levels, resulting in an LSB size of $152\mu\text{V}$ with $REF = 5\text{V}$. The ideal transfer function is shown in Figure 2. The output data is in 2's complement format.

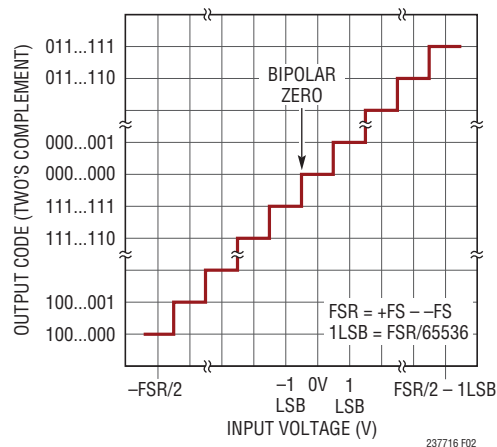

Figure 2. LTC2377-16 Transfer Function

ANALOG INPUT

The analog inputs of the LTC2377-16 are fully differential in order to maximize the signal swing that can be digitized. The analog inputs can be modeled by the equivalent circuit shown in Figure 3. The diodes at the input provide ESD protection. In the acquisition phase, each input sees approximately 45pF (C_{IN}) from the sampling CDAC in series with 40Ω (R_{ON}) from the on-resistance of the sampling switch. Any unwanted signal that is common to both inputs will be reduced by the common mode rejection of the ADC. The inputs draw a current spike while charging the C_{IN} capacitors during acquisition. During conversion, the analog inputs draw only a small leakage current.

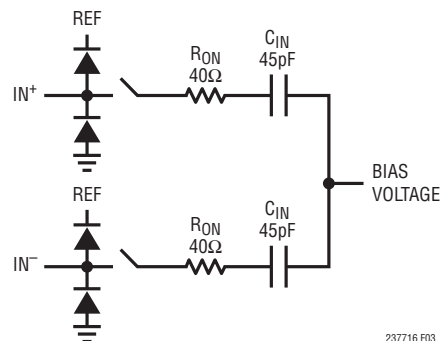

Figure 3. The Equivalent Circuit for the Differential Analog Input of the LTC2377-16

APPLICATIONS INFORMATION

INPUT DRIVE CIRCUITS

A low impedance source can directly drive the high impedance inputs of the LTC2377-16 without gain error. A high impedance source should be buffered to minimize settling time during acquisition and to optimize the distortion performance of the ADC. Minimizing settling time is important even for DC inputs, because the ADC inputs draw a current spike when entering acquisition.

For best performance, a buffer amplifier should be used to drive the analog inputs of the LTC2377-16. The amplifier provides low output impedance, which produces fast settling of the analog signal during the acquisition phase. It also provides isolation between the signal source and the current spike the ADC inputs draw.

Input Filtering

The noise and distortion of the buffer amplifier and signal source must be considered since they add to the ADC noise and distortion. Noisy input signals should be filtered prior to the buffer amplifier input with an appropriate filter to minimize noise. The simple 1-pole RC lowpass filter (LPF1) shown in Figure 4 is sufficient for many applications.

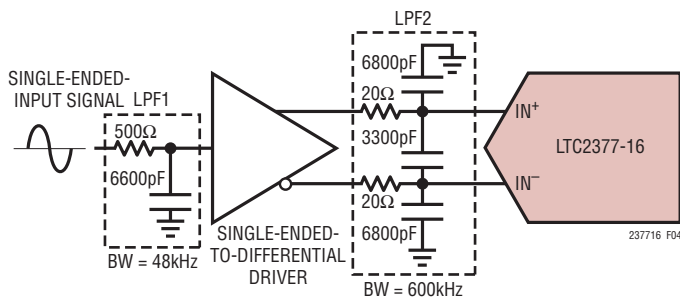

Figure 4. Input Signal Chain

Another filter network consisting of LPF2 should be used between the buffer and ADC input to both minimize the noise contribution of the buffer and to help minimize disturbances reflected into the buffer from sampling transients. Long RC time constants at the analog inputs will slow down the settling of the analog inputs. Therefore, LPF2 requires a wider bandwidth than LPF1. A buffer amplifier with a low noise density must be selected to minimize degradation of the SNR.

High quality capacitors and resistors should be used in the RC filters since these components can add distortion. NPO and silver mica type dielectric capacitors have excellent linearity. Carbon surface mount resistors can generate distortion from self heating and from damage that may occur during soldering. Metal film surface mount resistors are much less susceptible to both problems.

Single-Ended-to-Differential Conversion

For single-ended input signals, a single-ended to differential conversion circuit must be used to produce a differential signal at the inputs of the LTC2377-16. The LT6350 ADC driver is recommended for performing single-ended-to-differential conversions. The LT6350 is flexible and may be configured to convert single-ended signals of various amplitudes to the $\pm 5V$ differential input range of the LTC2377-16. The LT6350 is also available in H-grade to complement the extended temperature operation of the LTC2377-16 up to 125°C.

Figure 5a shows the LT6350 being used to convert a 0V to 5V single-ended input signal. In this case, the first amplifier is configured as a unity gain buffer and the single-ended input signal directly drives the high-impedance input of the amplifier. As shown in the FFT of Figure 5b, the LT6350 drives the LTC2377-16 to near full data sheet performance.

The LT6350 can also be used to buffer and convert large true bipolar signals which swing below ground to the $\pm 5V$ differential input range of the LTC2377-16 in order to maximize the signal swing that can be digitized. Figure 6a shows the LT6350 being used to convert a $\pm 10V$ true bipolar signal for use by the LTC2377-16. In this case, the first amplifier in the LT6350 is configured as an inverting amplifier stage, which acts to attenuate and level shift the input signal to the 0V to 5V input range of the LTC2377-16. In the inverting amplifier configuration, the single-ended input signal source no longer directly drives a high impedance input of the first amplifier. The input impedance is instead set by resistor R_{IN} . R_{IN} must be chosen carefully based on the source impedance of the signal source. Higher values of R_{IN} tend to degrade both the noise and distortion of the LT6350 and LTC2377-16 as a system.

APPLICATIONS INFORMATION

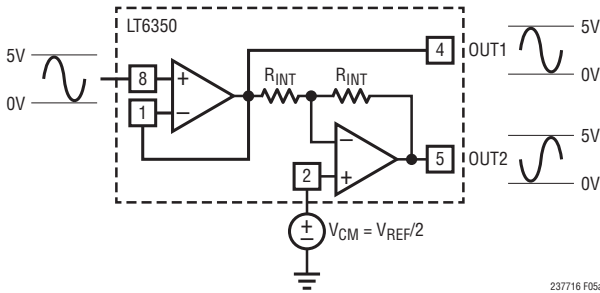

Figure 5a. LT6350 Converting a 0V-5V Single-Ended Signal to a ±5V Differential Input Signal

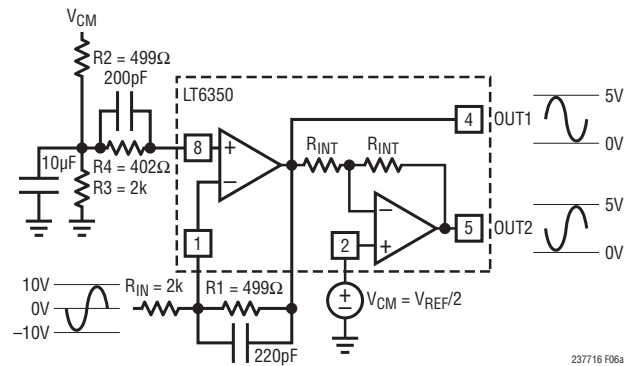

Figure 6a. LT6350 Converting a ±10V Single-Ended Signal to a ±5V Differential Input Signal

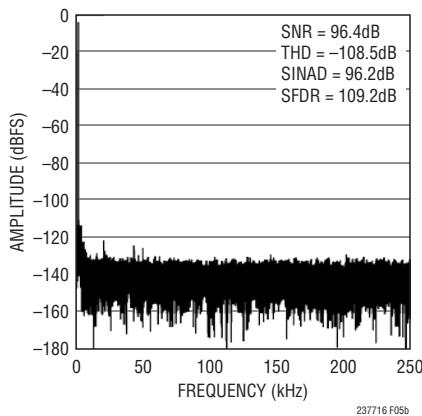

Figure 5b. 32k Point FFT Plot with $f_{IN} = 2\text{kHz}$ for Circuit Shown in Figure 5a

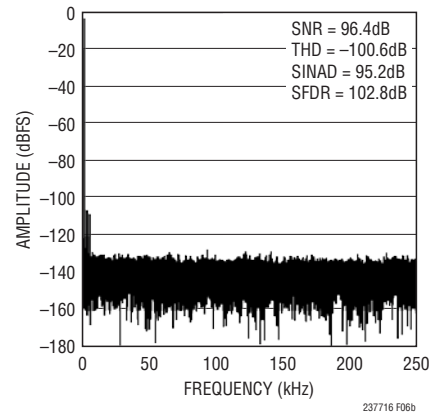

Figure 6b. 32k Point FFT Plot with $f_{IN} = 2\text{kHz}$ for Circuit Shown in Figure 6a

R1, R2, R3 and R4 must be selected in relation to R_{IN} to achieve the desired attenuation and to maintain a balanced input impedance in the first amplifier. Table 1 shows the resulting SNR and THD for several values of R_{IN} , R1, R2, R3 and R4 in this configuration. Figure 6b shows the resulting FFT when using the LT6350 as shown in Figure 6a.

Table 1. SNR, THD vs R_{IN} for ±10V Single-Ended Input Signal.

R_{IN} (Ω)	R1 (Ω)	R2 (Ω)	R3 (Ω)	R4 (Ω)	SNR (dB)	THD (dB)
2k	499	499	2k	402	96.4	-101
10k	2.49k	2.49k	10k	2k	96.3	-92
100k	24.9k	24.9k	100k	20k	96.3	-98

Fully Differential Inputs

To achieve the full distortion performance of the LTC2377-16, a low distortion fully differential signal source driven through the LT6203 configured as two unity gain buffers as shown in Figure 7 can be used to get the full data sheet THD specification of -123dB.

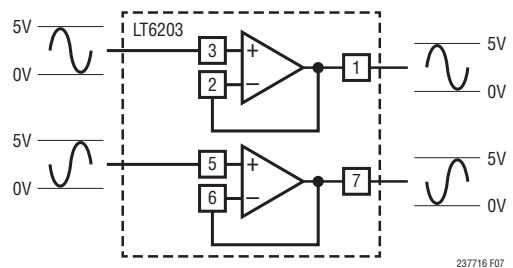

Figure 7. LT6203 Buffering a Fully Differential Signal Source

Digital Gain Compression

The LTC2377-16 offers a digital gain compression (DGC) feature which defines the full-scale input swing to be between 10% and 90% of the $\pm V_{REF}$ analog input range. To enable digital gain compression, bring the REF/DGC pin low. This feature allows the LT6350 to be powered off of a single +5.5V supply since each input swings between 0.5V and 4.5V as shown in Figure 8. Needing only one

237716fa

APPLICATIONS INFORMATION

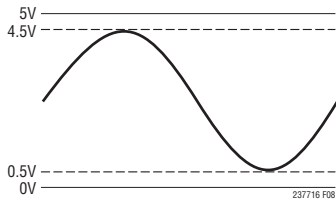

Figure 8. Input Swing of the LTC2377 with Gain Compression Enabled

positive supply to power the LT6350 results in additional power savings for the entire system.

Figure 9a shows how to configure the LT6350 to accept a $\pm 10V$ true bipolar input signal and attenuate and level shift the signal to the reduced input range of the LTC2377-16 when digital gain compression is enabled. Figure 9b shows an FFT plot with the LTC2377-16 being driven by the LT6350 with digital gain compression enabled.

ADC REFERENCE

The LTC2377-16 requires an external reference to define its input range. A low noise, low temperature drift reference is critical to achieving the full data sheet performance of the ADC. Linear Technology offers a portfolio of high performance references designed to meet the needs of

many applications. With its small size, low power and high accuracy, the LTC6655-5 is particularly well suited for use with the LTC2377-16. The LTC6655-5 offers 0.025% (max) initial accuracy and 2ppm/ $^{\circ}C$ (max) temperature coefficient for high precision applications. The LTC6655-5 is fully specified over the H-grade temperature range and complements the extended temperature operation of the LTC2377-16 up to 125 $^{\circ}C$. We recommend bypassing the LTC6655-5 with a 47 μF ceramic capacitor (X5R, 0805 size) close to the REF pin.

The REF pin of the LTC2377-16 draws charge (Q_{CONV}) from the 47 μF bypass capacitor during each conversion cycle. The reference replenishes this charge with a DC current, $I_{REF} = Q_{CONV}/t_{CYC}$. The DC current draw of the REF pin, I_{REF} , depends on the sampling rate and output code. If the LTC2377-16 is used to continuously sample a signal at a constant rate, the LTC6655-5 will keep the deviation of the reference voltage over the entire code span to less than 0.5LSBs.

When idling, the REF pin on the LTC2377-16 draws only a small leakage current ($< 1\mu A$). In applications where a burst of samples is taken after idling for long periods as shown in Figure 10, I_{REF} quickly goes from approximately

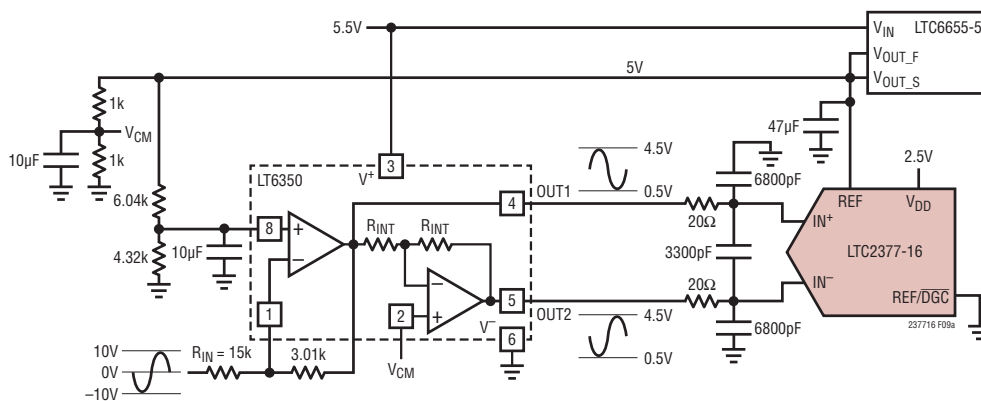

Figure 9a. LT6350 Configured to Accept a $\pm 10V$ Input Signal While Running Off of a Single 5.5V Supply When Digital Gain Compression Is Enabled in the LTC2377-16

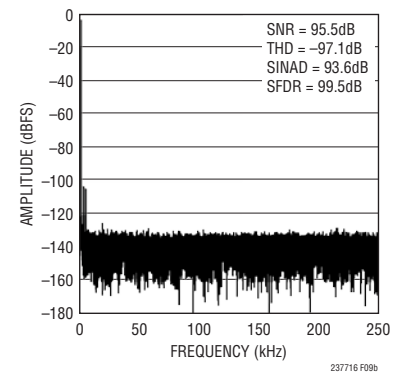

Figure 9b. 32k Point FFT Plot with $f_{IN} = 2kHz$ for Circuit Shown in Figure 9a

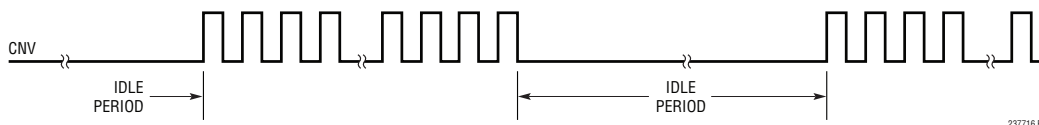

Figure 10. CNV Waveform Showing Burst Sampling

APPLICATIONS INFORMATION

0 μ A to a maximum of 0.4mA at 500ksps. This step in DC current draw triggers a transient response in the reference that must be considered since any deviation in the reference output voltage will affect the accuracy of the output code. In applications where the transient response of the reference is important, the fast settling LTC6655-5 reference is also recommended.

DYNAMIC PERFORMANCE

Fast Fourier Transform (FFT) techniques are used to test the ADC's frequency response, distortion and noise at the rated throughput. By applying a low distortion sine wave and analyzing the digital output using an FFT algorithm, the ADC's spectral content can be examined for frequencies outside the fundamental. The LTC2377-16 provides guaranteed tested limits for both AC distortion and noise measurements.

Signal-to-Noise and Distortion Ratio (SINAD)

The signal-to-noise and distortion ratio (SINAD) is the ratio between the RMS amplitude of the fundamental input frequency and the RMS amplitude of all other frequency components at the A/D output. The output is band-limited to frequencies from above DC and below half the sampling frequency. Figure 11 shows that the LTC2377-16 achieves a typical SINAD of 97dB at a 500kHz sampling rate with a 2kHz input.

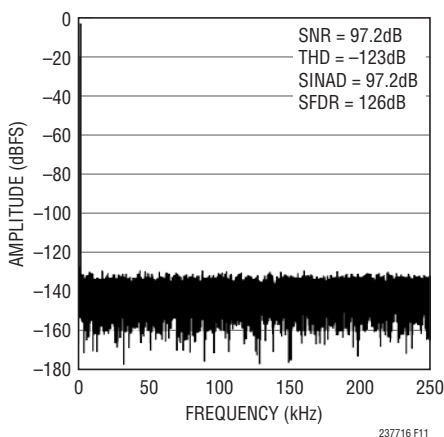

Figure 11. 32k Point FFT with $f_{IN} = 2\text{kHz}$ of the LTC2377-16

Signal-to-Noise Ratio (SNR)

The signal-to-noise ratio (SNR) is the ratio between the RMS amplitude of the fundamental input frequency and the RMS amplitude of all other frequency components except the first five harmonics and DC. Figure 11 shows that the LTC2377-16 achieves a typical SNR of 97dB at a 500kHz sampling rate with a 2kHz input.

Total Harmonic Distortion (THD)

Total Harmonic Distortion (THD) is the ratio of the RMS sum of all harmonics of the input signal to the fundamental itself. The out-of-band harmonics alias into the frequency band between DC and half the sampling frequency ($f_{SAMPL}/2$). THD is expressed as:

$$\text{THD} = 20 \log \frac{\sqrt{V_2^2 + V_3^2 + V_4^2 + \dots + V_N^2}}{V_1}$$

where V_1 is the RMS amplitude of the fundamental frequency and V_2 through V_N are the amplitudes of the second through Nth harmonics.

POWER CONSIDERATIONS

The LTC2377-16 provides two power supply pins: the 2.5V power supply (V_{DD}), and the digital input/output interface power supply (OV_{DD}). The flexible OV_{DD} supply allows the LTC2377-16 to communicate with any digital logic operating between 1.8V and 5V, including 2.5V and 3.3V systems.

Power Supply Sequencing

The LTC2377-16 does not have any specific power supply sequencing requirements. Care should be taken to adhere to the maximum voltage relationships described in the Absolute Maximum Ratings section. The LTC2377-16 has a power-on-reset (POR) circuit that will reset the LTC2377-16 at initial power-up or whenever the power supply voltage drops below 1V. Once the supply voltage re-enters the nominal supply voltage range, the POR will reinitialize the ADC. No conversions should be initiated until 20 μ s after a POR event to ensure the reinitialization period has ended. Any conversions initiated before this time will produce invalid results.

237716fa

APPLICATIONS INFORMATION

TIMING AND CONTROL

CNV Timing

The LTC2377-16 conversion is controlled by CNV. A rising edge on CNV will start a conversion and power up the LTC2377-16. Once a conversion has been initiated, it cannot be restarted until the conversion is complete. For optimum performance, CNV should be driven by a clean low jitter signal. Converter status is indicated by the BUSY output which remains high while the conversion is in progress. To ensure that no errors occur in the digitized results, any additional transitions on CNV should occur within 40ns from the start of the conversion or after the conversion has been completed. Once the conversion has completed, the LTC2377-16 powers down and begins acquiring the input signal.

Acquisition

A proprietary sampling architecture allows the LTC2377-16 to begin acquiring the input signal for the next conversion 527ns after the start of the current conversion. This extends the acquisition time to 1.46 μ s, easing settling requirements and allowing the use of extremely low power ADC drivers. (Refer to the Timing Diagram.)

Internal Conversion Clock

The LTC2377-16 has an internal clock that is trimmed to achieve a maximum conversion time of 1.5 μ s.

Auto Power-Down

The LTC2377-16 automatically powers down after a conversion has been completed and powers up once a new conversion is initiated on the rising edge of CNV. During power down, data from the last conversion can be clocked out. To minimize power dissipation during power down, disable SDO and turn off SCK. The auto power-down feature will reduce the power dissipation of the LTC2377-16 as the sampling frequency is reduced. Since power is consumed only during a conversion, the LTC2377-16 remains powered-down for a larger fraction of the conversion cycle (t_{CYC}) at lower sample rates, thereby reducing the average power dissipation which scales with the sampling rate as shown in Figure 12.

DIGITAL INTERFACE

The LTC2377-16 has a serial digital interface. The flexible OV_{DD} supply allows the LTC2377-16 to communicate with any digital logic operating between 1.8V and 5V, including 2.5V and 3.3V systems.

The serial output data is clocked out on the SDO pin when an external clock is applied to the SCK pin if SDO is enabled. Clocking out the data after the conversion will yield the best performance. With a shift clock frequency of at least 40MHz, a 500ksp/s throughput is still achieved. The serial output data changes state on the rising edge of SCK and can be captured on the falling edge or next rising edge of SCK. D15 remains valid till the first rising edge of SCK.

The serial interface on the LTC2377-16 is simple and straightforward to use. The following sections describe the operation of the LTC2377-16. Several modes are provided depending on whether a single or multiple ADCs share the SPI bus or are daisy-chained.

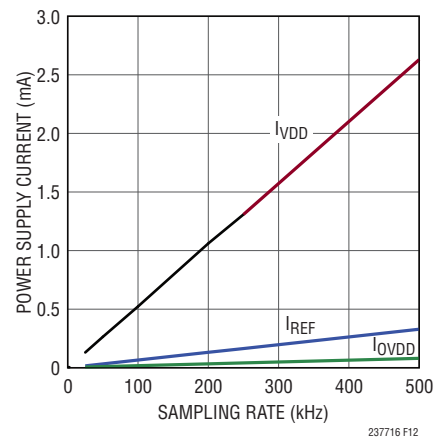

Figure 12. Power Supply Current of the LTC2377-16 Versus Sampling Rate

APPLICATIONS INFORMATION

Normal Mode, Single Device

When CHAIN = 0, the LTC2377-16 operates in normal mode. In normal mode, RDL/SDI enables or disables the serial data output pin SDO. If RDL/SDI is high, SDO is in high impedance. If RDL/SDI is low, SDO is driven.

Figure 13 shows a single LTC2377-16 operated in normal mode with CHAIN and RDL/SDI tied to ground. With RDL/SDI grounded, SDO is enabled and the MSB(D15) of the new conversion data is available at the falling edge of BUSY. This is the simplest way to operate the LTC2377-16.

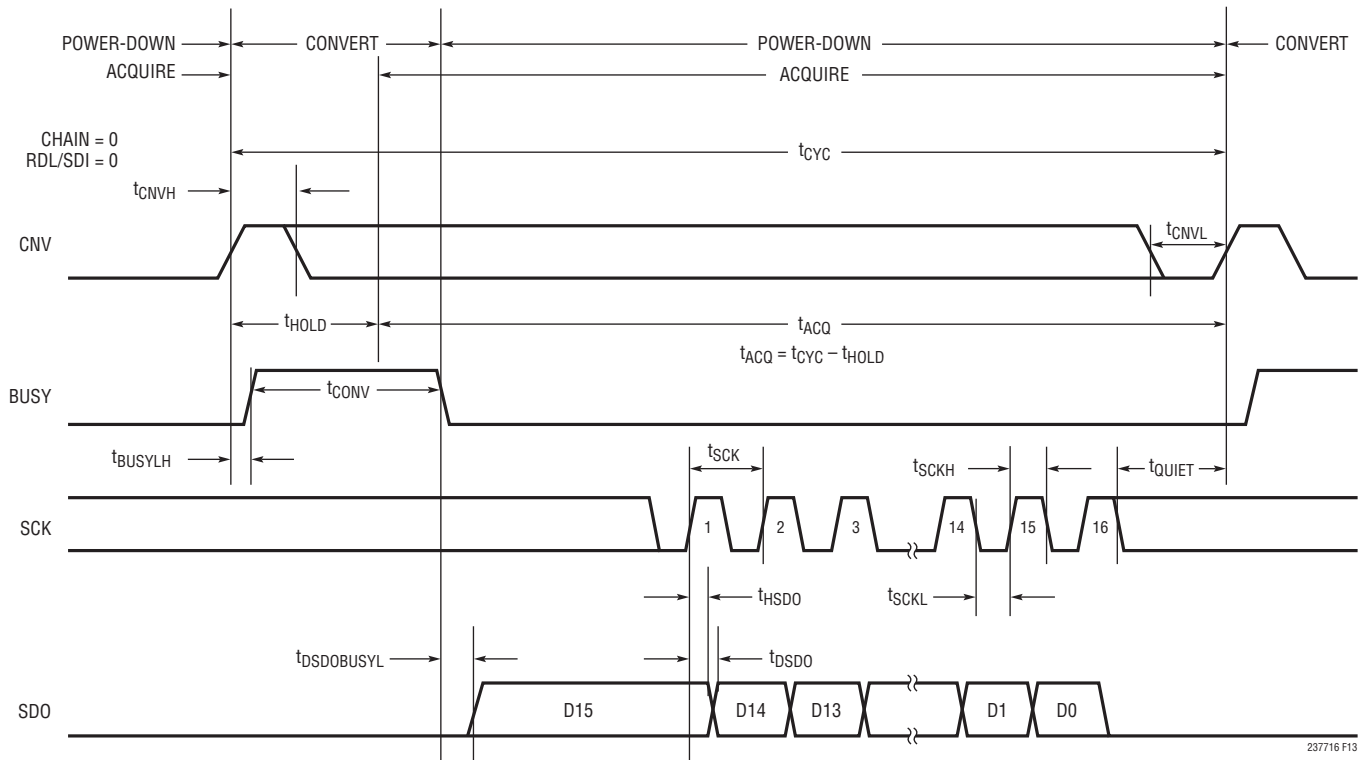
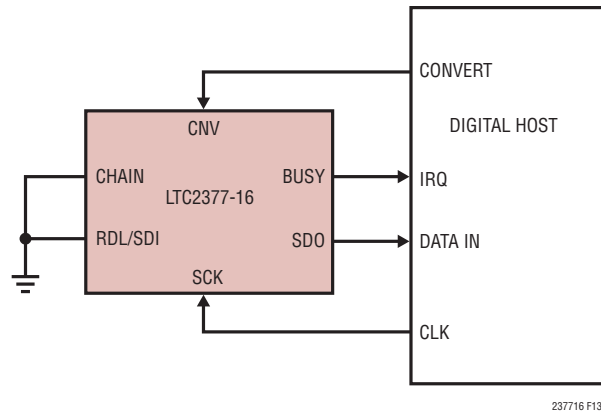

Figure 13. Using a Single LTC2377-16 in Normal Mode

APPLICATIONS INFORMATION

Normal Mode, Multiple Devices

Figure 14 shows multiple LTC2377-16 devices operating in normal mode (CHAIN = 0) sharing CNV, SCK and SDO. By sharing CNV, SCK and SDO, the number of required signals to operate multiple ADCs in parallel is reduced.

Since SDO is shared, the RDL/SDI input of each ADC must be used to allow only one LTC2377-16 to drive SDO at a time in order to avoid bus conflicts. As shown in Figure 14, the RDL/SDI inputs idle high and are individually brought low to read data out of each device between conversions. When RDL/SDI is brought low, the MSB of the selected device is output onto SDO.

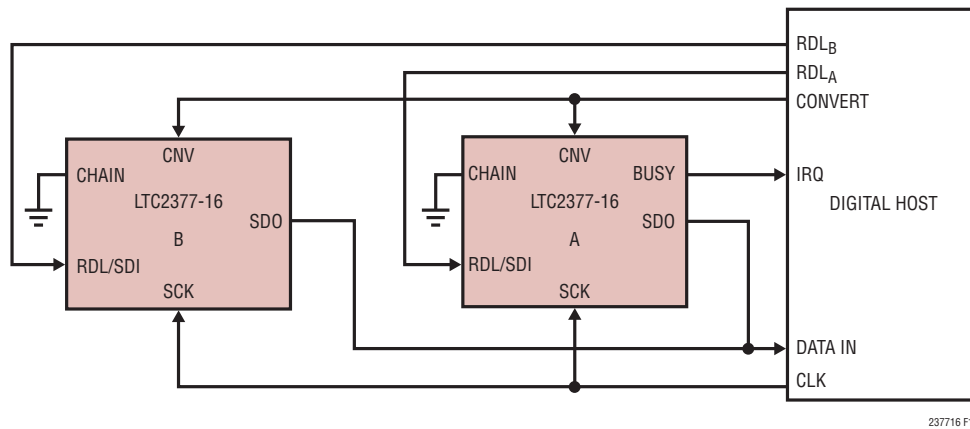

237716 F14a

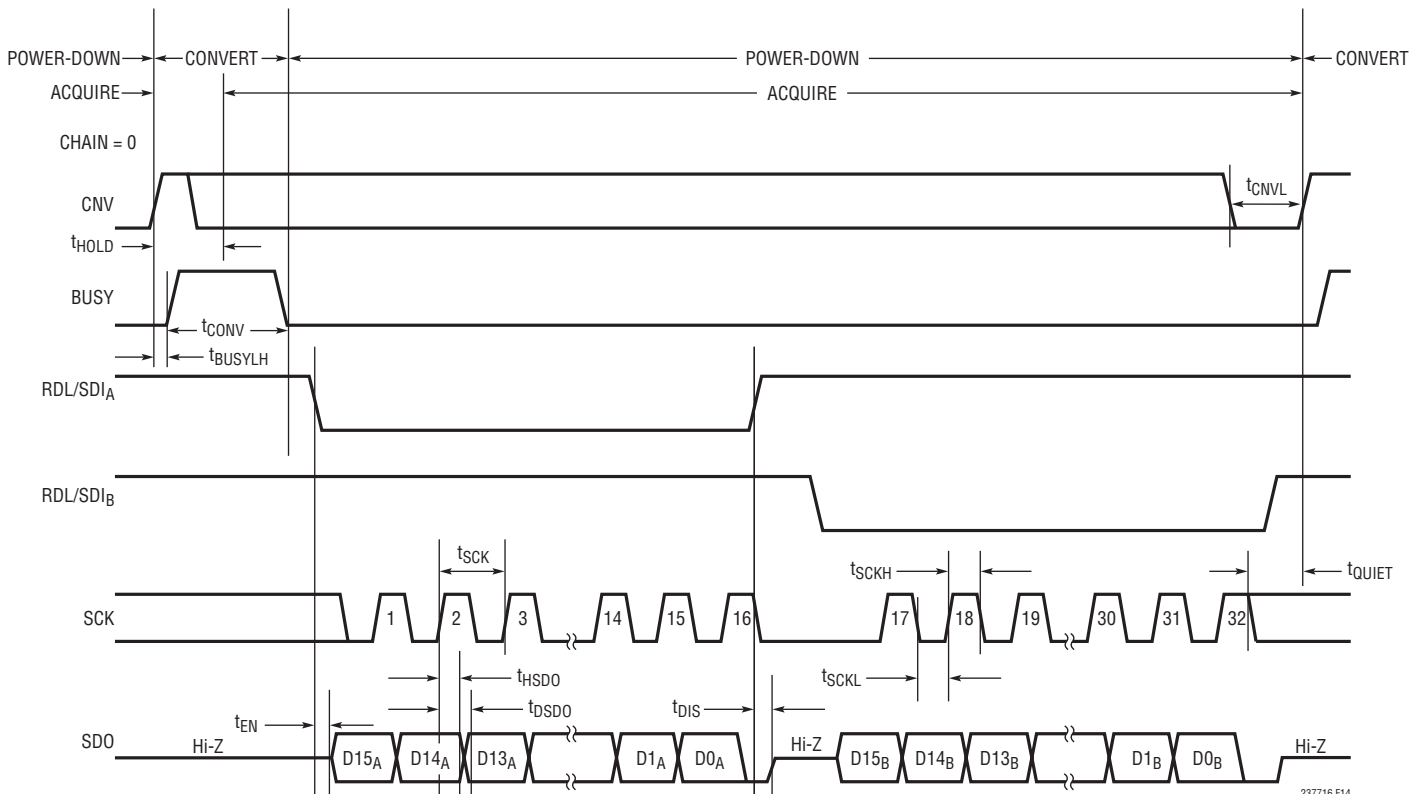

237716 F14

Figure 14. Normal Mode With Multiple Devices Sharing CNV, SCK and SDO

APPLICATIONS INFORMATION

Chain Mode, Multiple Devices

When CHAIN = OV_{DD} , the LTC2377-16 operates in chain mode. In chain mode, SDO is always enabled and RDL/SDI serves as the serial data input pin (SDI) where daisy-chain data output from another ADC can be input.

This is useful for applications where hardware constraints may limit the number of lines needed to interface to a large number of converters. Figure 15 shows an example with two daisy-chained devices. The MSB of converter A will appear at SDO of converter B after 16 SCK cycles. The MSB of converter A is clocked in at the SDI/RDL pin of converter B on the rising edge of the first SCK.

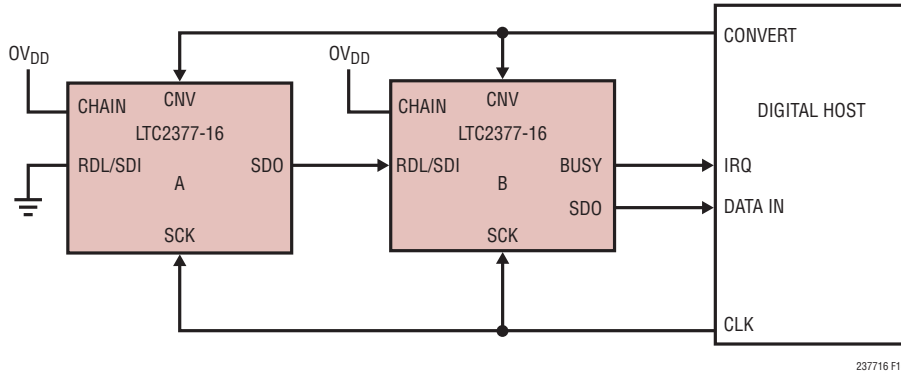

237716 F16a

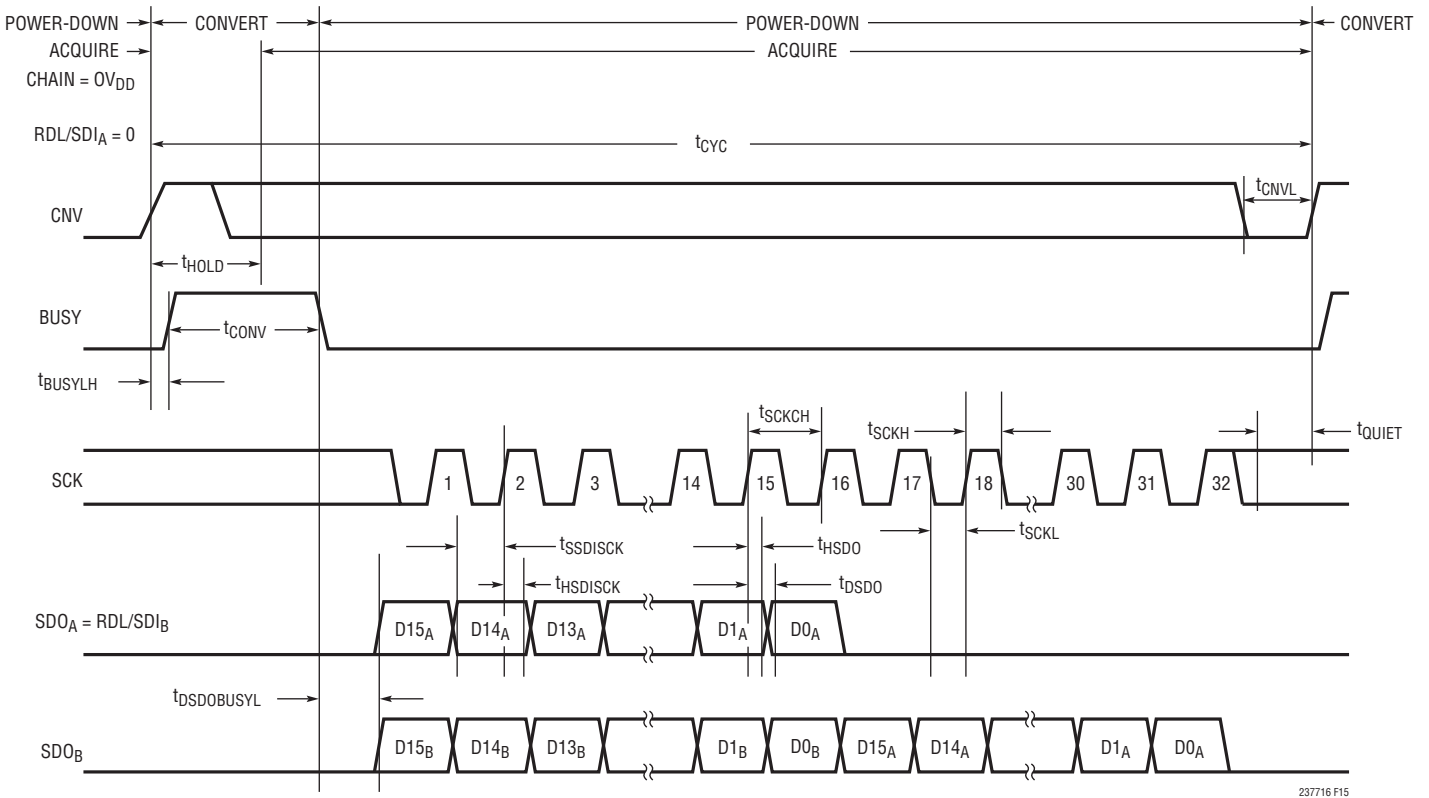

237716 F15

Figure 15. Chain Mode Timing Diagram

BOARD LAYOUT

To obtain the best performance from the LTC2377-16 a printed circuit board is recommended. Layout for the printed circuit board (PCB) should ensure the digital and analog signal lines are separated as much as possible. In particular, care should be taken not to run any digital clocks or signals alongside analog signals or underneath the ADC.

Recommended Layout

The following is an example of a recommended PCB layout. A single solid ground plane is used. Bypass capacitors to the supplies are placed as close as possible to the supply pins. Low impedance common returns for these bypass capacitors are essential to the low noise operation of the ADC. The analog input traces are screened by ground. For more details and information refer to DC1783A, the evaluation kit for the LTC2377-16.

Partial Top Silkscreen

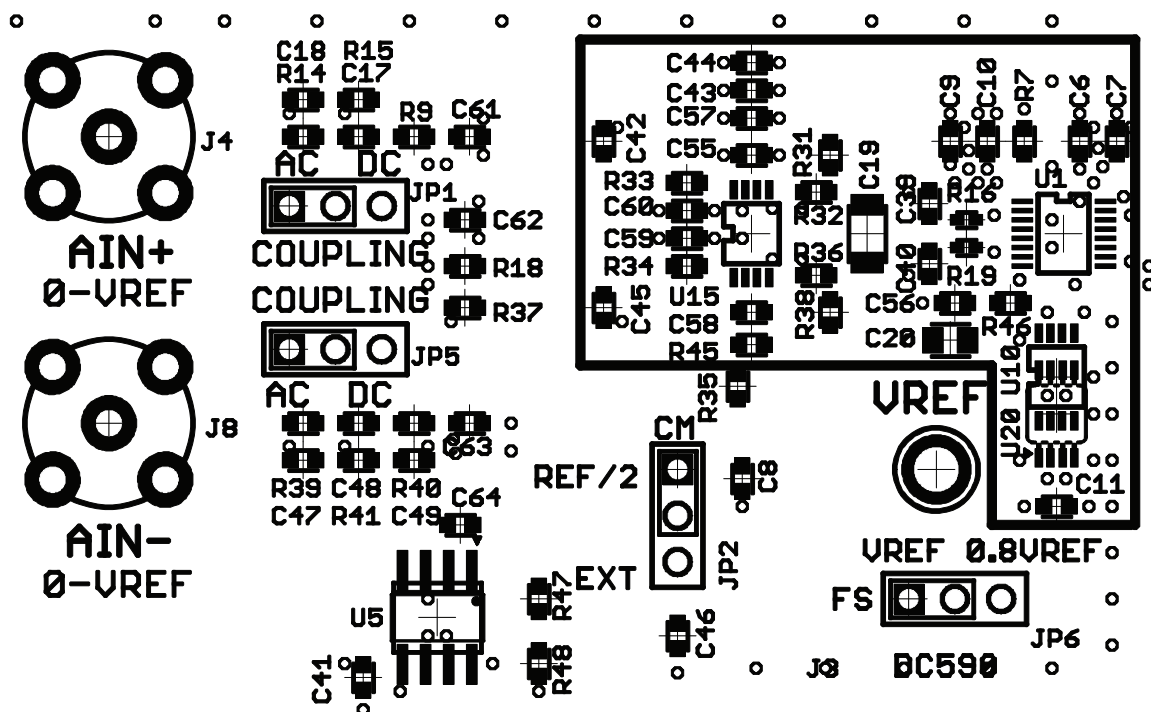

BOARD LAYOUT

Partial Layer 1 Component Side

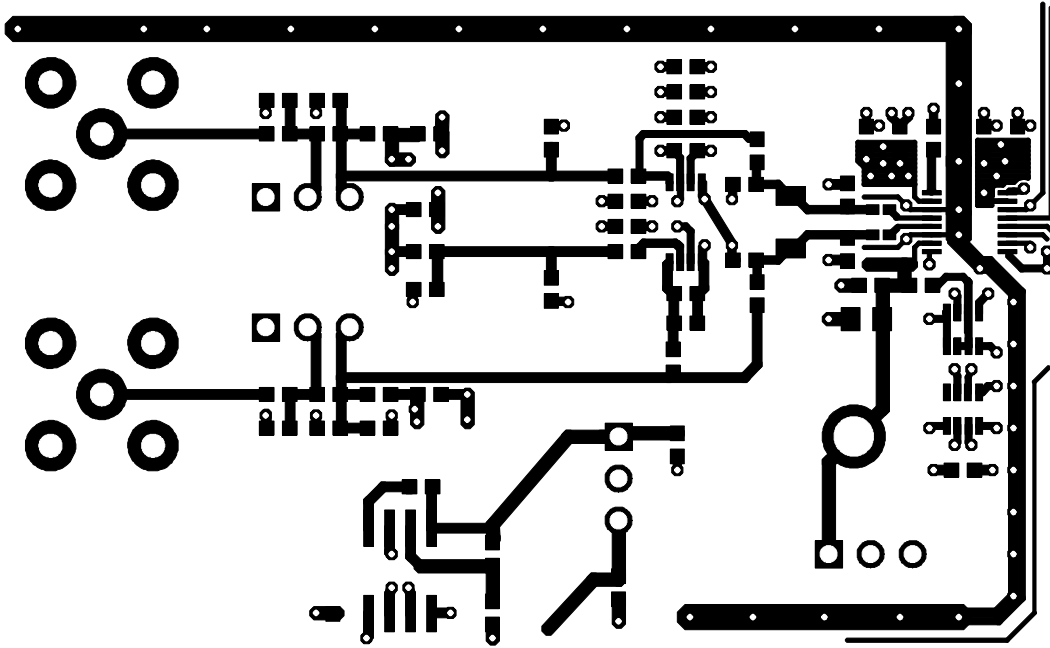

Partial Layer 2 Ground Plane

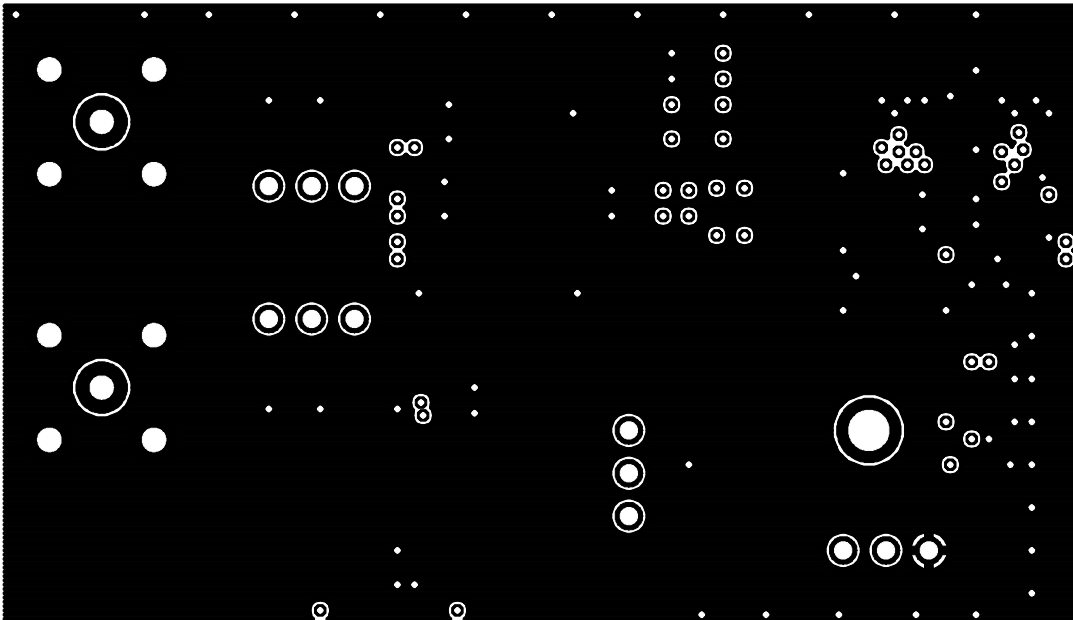

BOARD LAYOUT

Partial Layer 3 PWR Plane

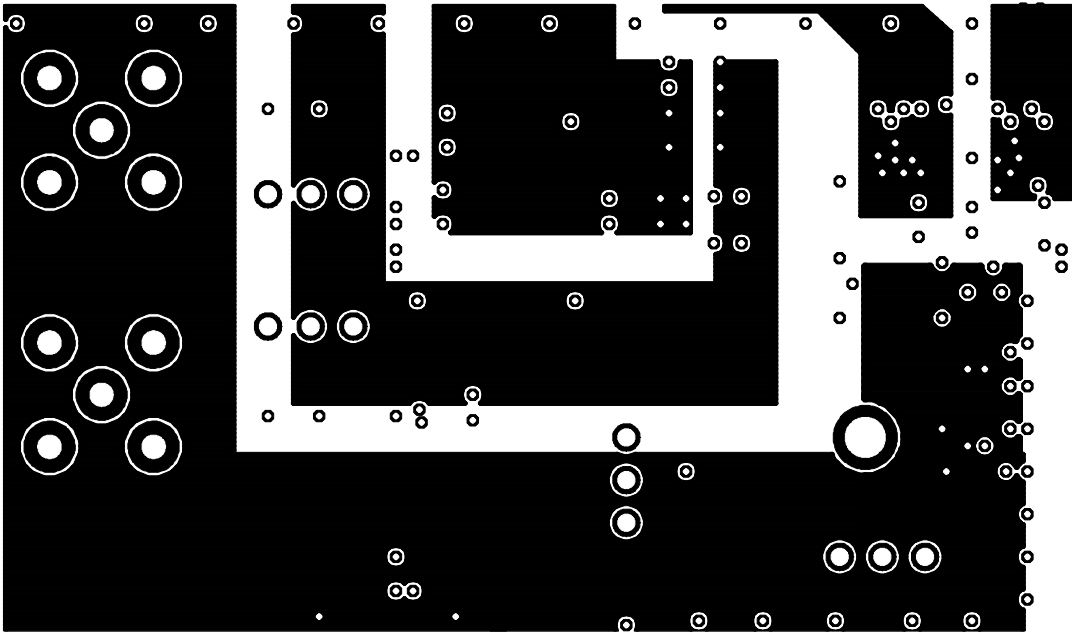

Partial Layer 4 Bottom Layer

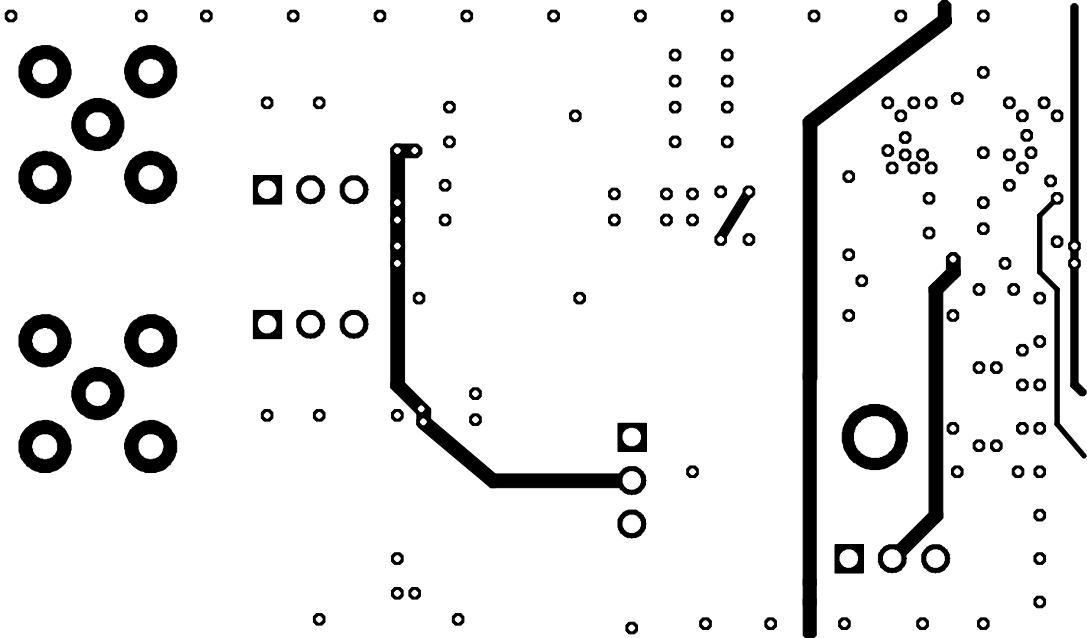

BOARD LAYOUT

Partial Schematic of Demo Board

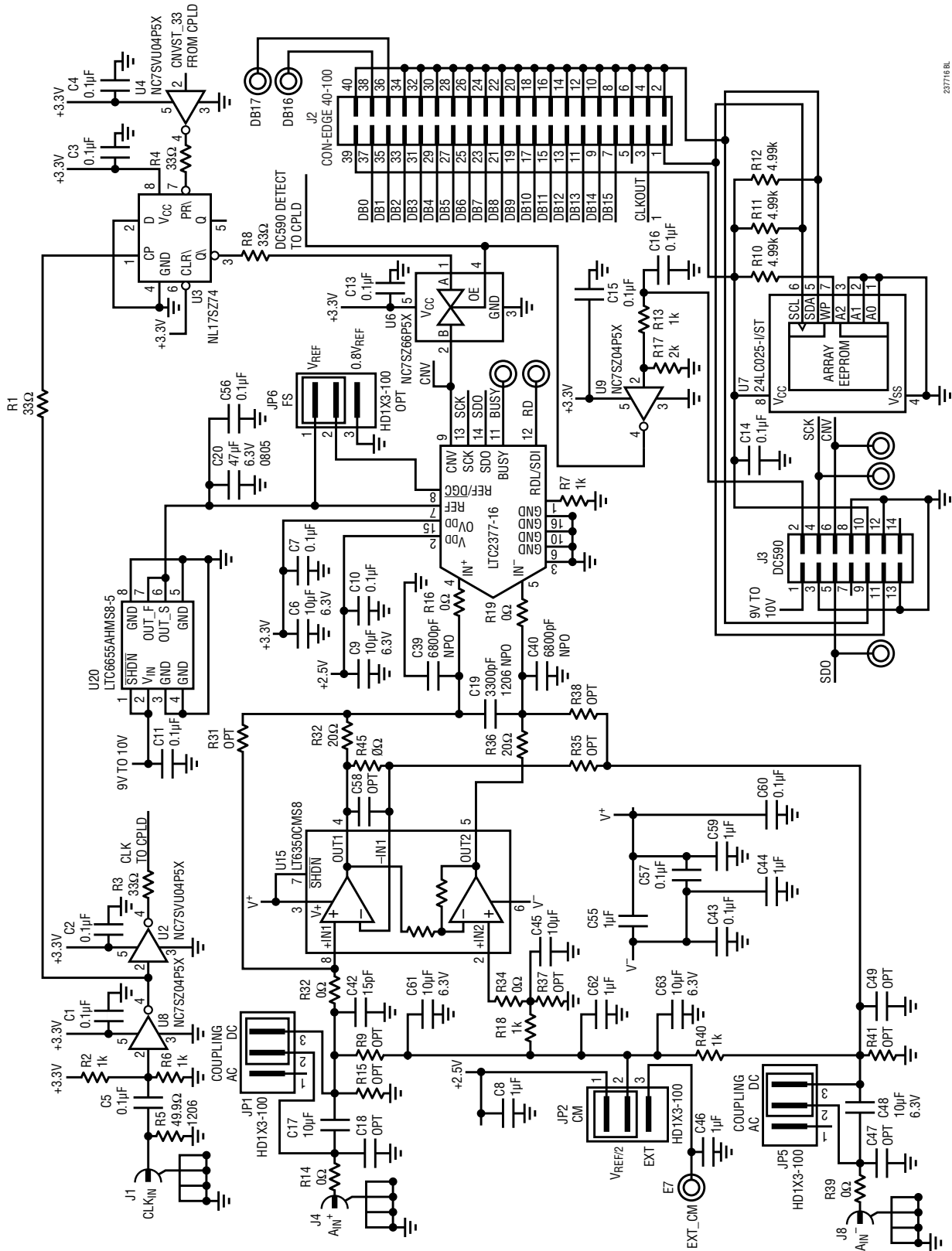

237716 RL

PACKAGE DESCRIPTION

Please refer to <http://www.linear.com/product/LTC2377-16#packaging> for the most recent package drawings.

DE Package 16-Lead Plastic DFN (4mm × 3mm) (Reference LTC DWG # 05-08-1732 Rev 0)

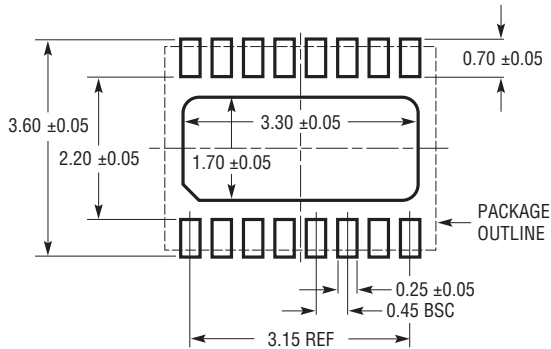

RECOMMENDED SOLDER PAD PITCH AND DIMENSIONS
APPLY SOLDER MASK TO AREAS THAT ARE NOT SOLDERED

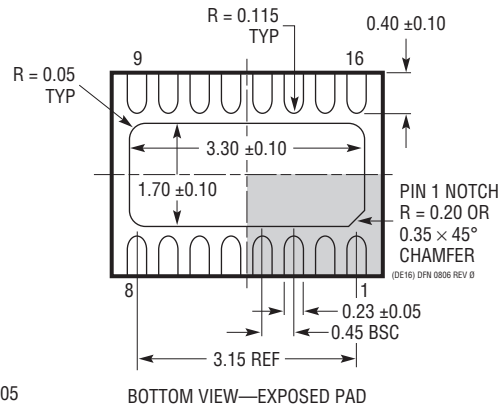
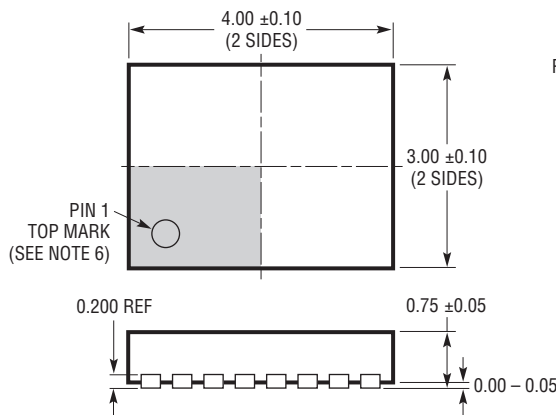

NOTE:

1. DRAWING PROPOSED TO BE MADE VARIATION OF VERSION (WGED-3) IN JEDEC PACKAGE OUTLINE MO-229
2. DRAWING NOT TO SCALE
3. ALL DIMENSIONS ARE IN MILLIMETERS
4. DIMENSIONS OF EXPOSED PAD ON BOTTOM OF PACKAGE DO NOT INCLUDE MOLD FLASH. MOLD FLASH, IF PRESENT, SHALL NOT EXCEED 0.15mm ON ANY SIDE
5. EXPOSED PAD SHALL BE SOLDER PLATED
6. SHADED AREA IS ONLY A REFERENCE FOR PIN 1 LOCATION ON THE TOP AND BOTTOM OF PACKAGE

PACKAGE DESCRIPTION

Please refer to <http://www.linear.com/product/LTC2377-16#packaging> for the most recent package drawings.

MS Package 16-Lead Plastic MSOP

(Reference LTC DWG # 05-08-1669 Rev A)

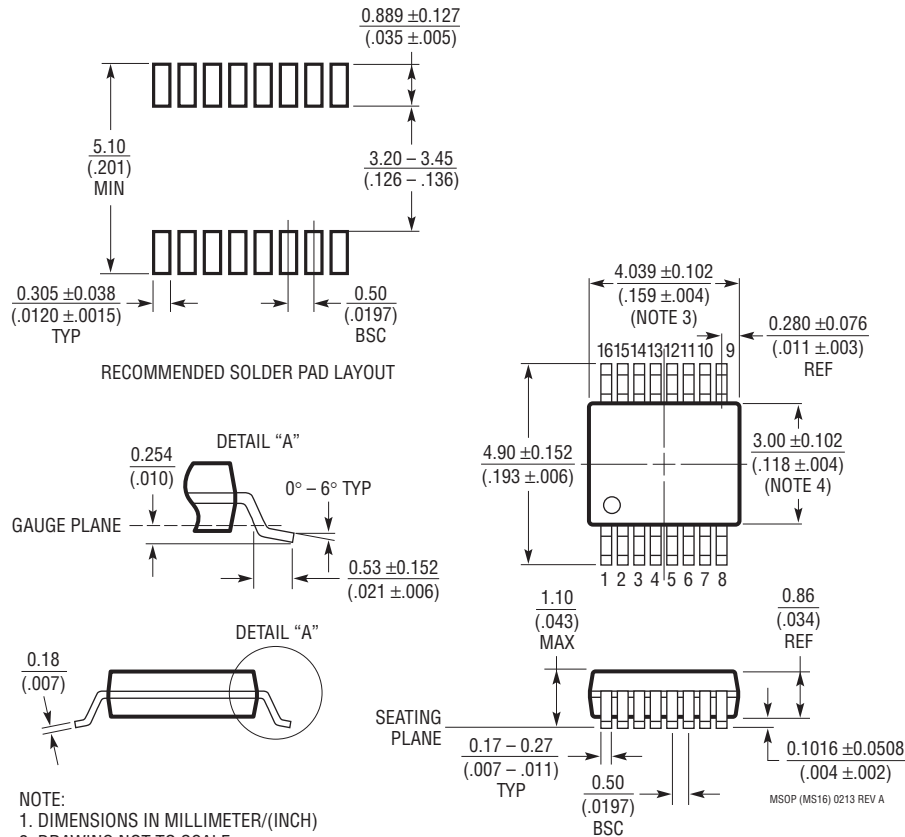

NOTE:

1. DIMENSIONS IN MILLIMETER/(INCH)
2. DRAWING NOT TO SCALE
3. DIMENSION DOES NOT INCLUDE MOLD FLASH, PROTRUSIONS OR GATE BURRS.
MOLD FLASH, PROTRUSIONS OR GATE BURRS SHALL NOT EXCEED 0.152mm (.006") PER SIDE
4. DIMENSION DOES NOT INCLUDE INTERLEAD FLASH OR PROTRUSIONS.
INTERLEAD FLASH OR PROTRUSIONS SHALL NOT EXCEED 0.152mm (.006") PER SIDE
5. LEAD COPLANARITY (BOTTOM OF LEADS AFTER FORMING) SHALL BE 0.102mm (.004") MAX

MSOP (MS16) 0213 REV A

REVISION HISTORY

REV	DATE	DESCRIPTION	PAGE NUMBER
A	09/16	Updated graphs G01, G02 and G03.	6