

DESCRIPTION

Introduction

Demonstration circuit 2159 provides USB connectivity to an FMC compatible FPGA evaluation board via an FT2232H Dual USB UART/FIFO. It is used in conjunction with various FPGA boards and a Linear Technology data converter evaluation board as part of an evaluation system for Linear Technology products.

Design files for this circuit board are available at <http://www.linear.com/demo/DC2159A>

LT, LT, LTC, LTM, Linear Technology and the Linear logo are registered trademarks of Linear Technology Corporation. All other trademarks are the property of their respective owners.

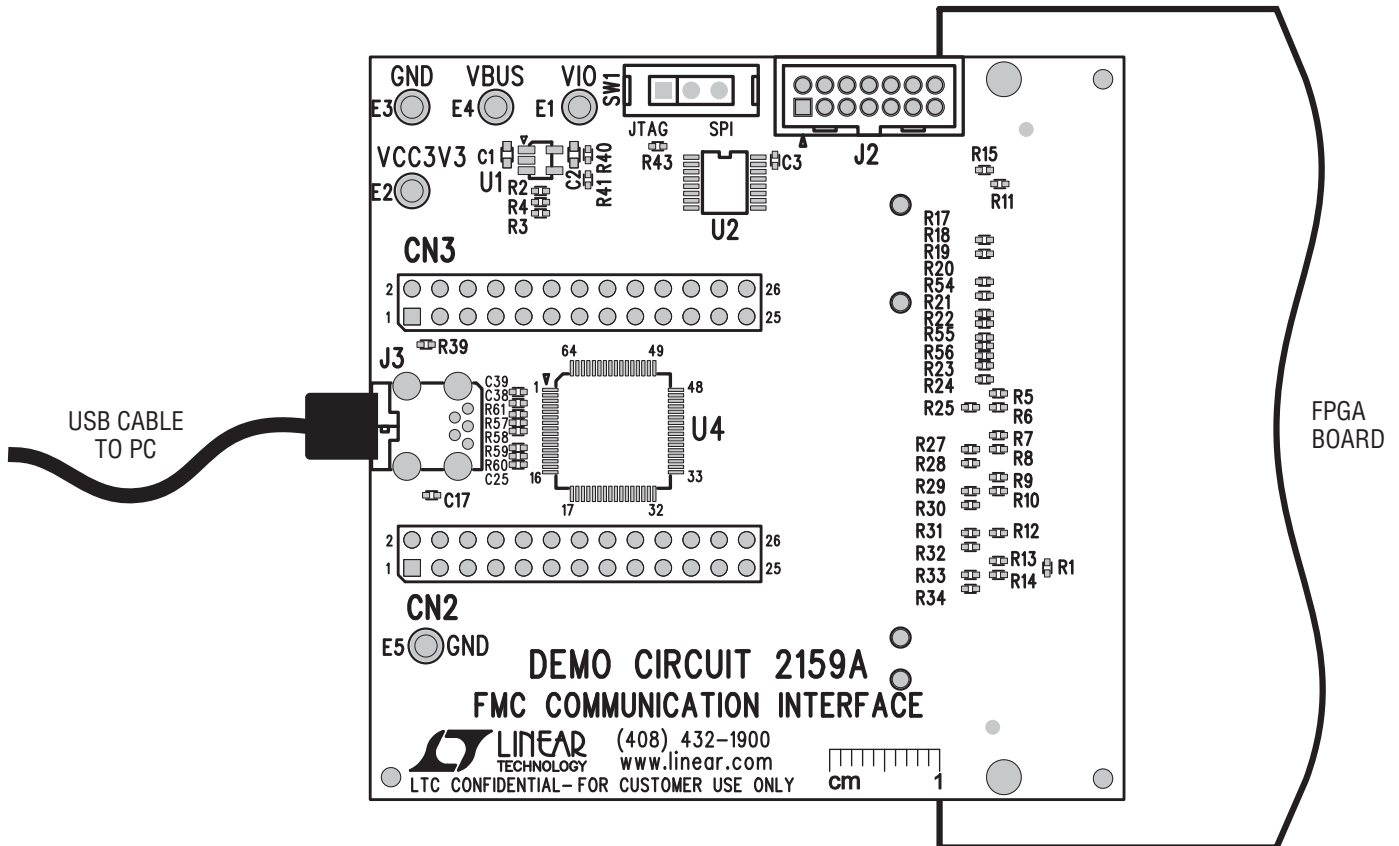

Figure 1. Basic Connections

QUICK START PROCEDURE

Make sure FPGA board power is OFF and no USB cable is connected. Seat the FMC connector on the back side of DC2159 to the mating connector on the FPGA board, pressing evenly across the connector and providing support on the back side of the FPGA board. Install two 4-40 nuts on the two standoffs to secure the connection. Verify that SW1 is in the SPI position.

Follow any additional setup instructions for the data converter board (For example, DC1974 shown in Figure 2.)

Only insert the USB cable AFTER the FPGA board is powered up. (The FT2232 I/O power is only enabled when the

FPGA board is powered up; inserting the USB cable without I/O power causes incorrect identification of the FT2232.)

JTAG Port

J2 provides a JTAG connection that may be used in some evaluation setups. Refer to the data converter's demo manual.

Other Connections

All test points are for factory use only. Do not make any other connections.

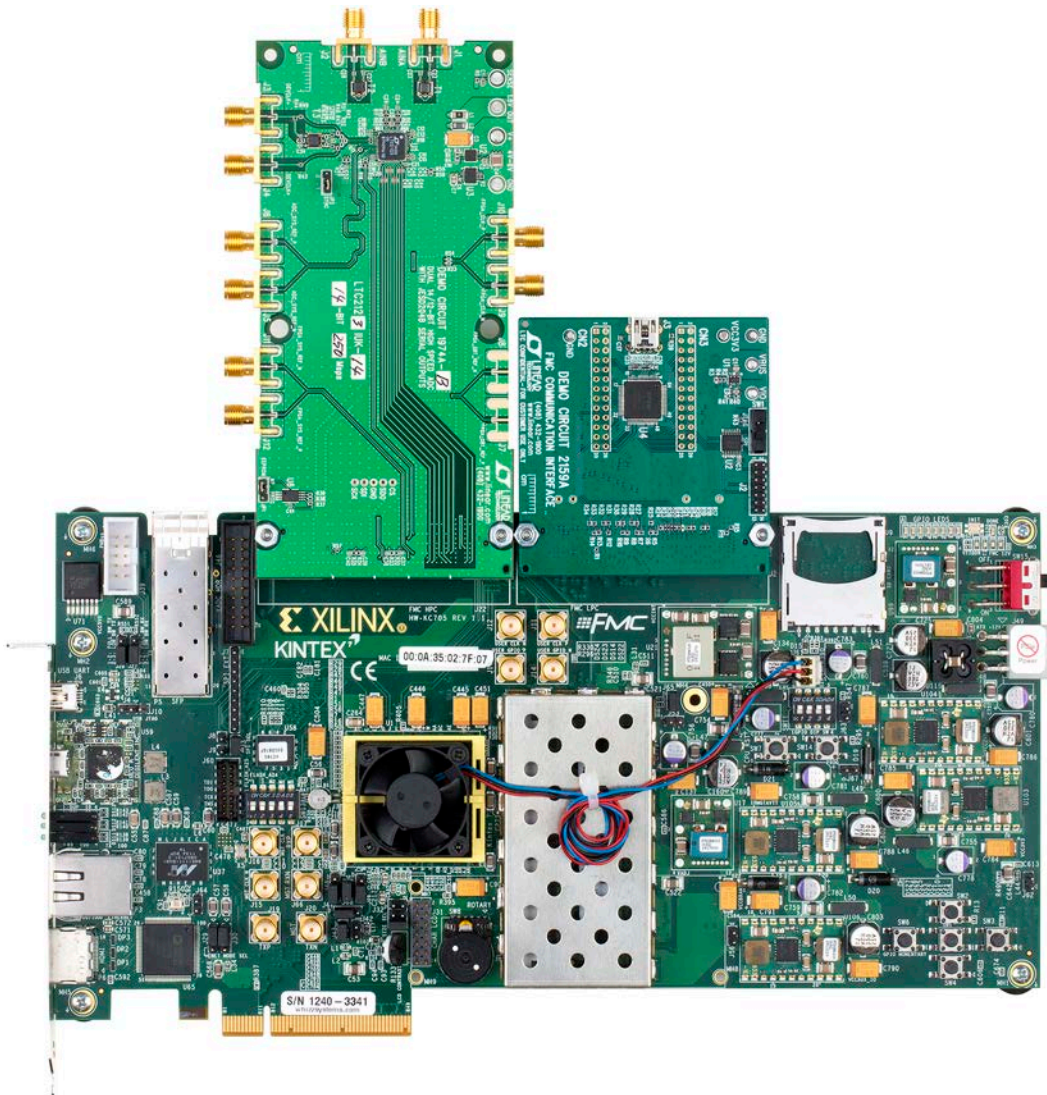
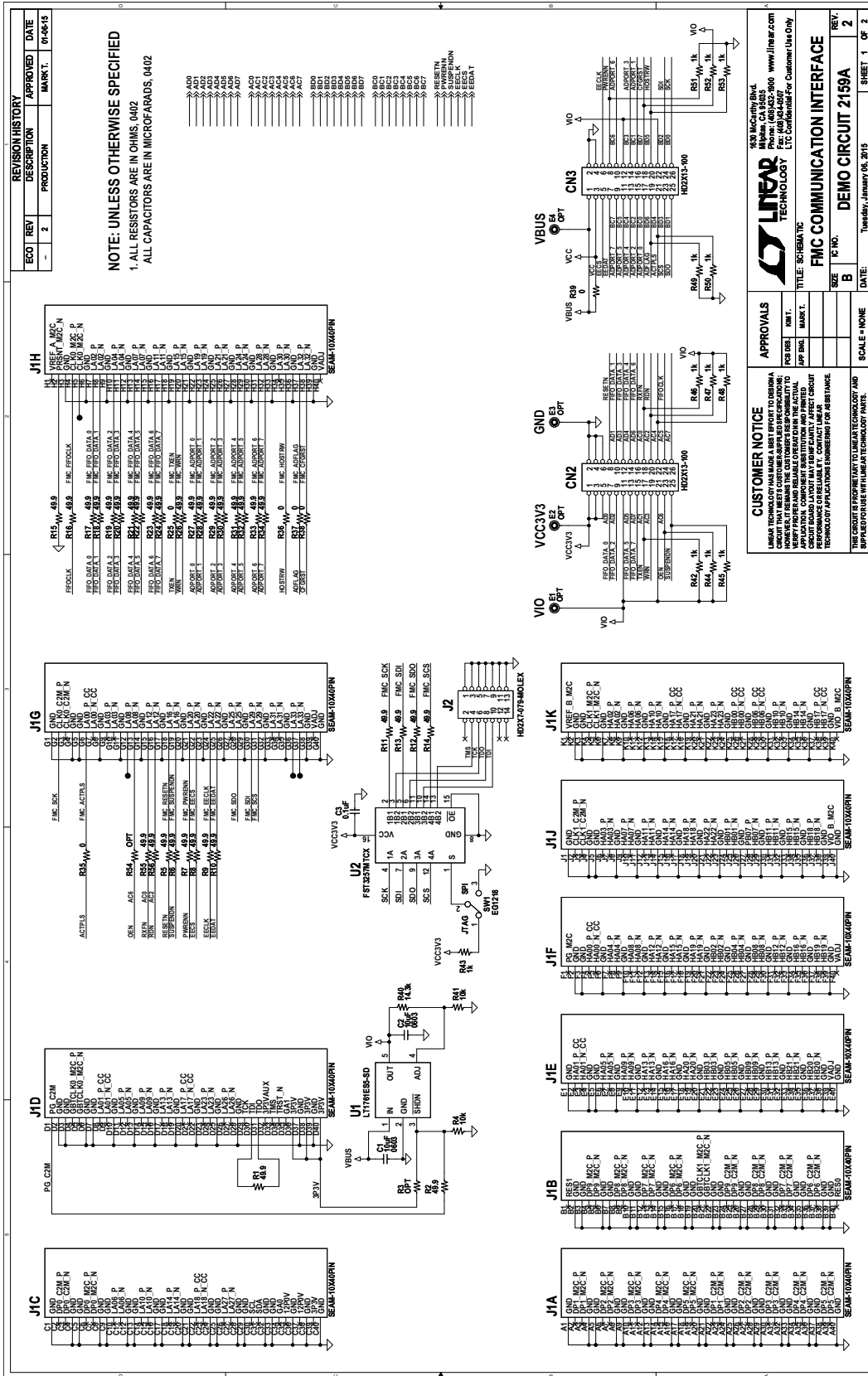

Figure 2. Complete LTC2123 Demonstration System (DC2159, DC1974, and Xilinx KC705 Board)

PARTS LIST

ITEM	QTY	REFERENCE	PART DESCRIPTION	MANUFACTURER/PART NUMBER
Required Circuit Components				
1	0	CN2, CN3	SOCKET, 2X13-100, HD2X13-100	SAMTEC, BCS-113-L-D-TE
2	2	C1, C2	CAP., X5R, 10µF 6.3V, 20%, 0603	AVX, 06036D106MAT2A
3	13	C3, C5-C14, C24, C25	CAP., X7R, 0.1µF, 10V, 10%, 0402	AVX, 0402ZC104KAT2A
4	5	C4, C15, C19, C20, C21	CAP., X5R, 4.7µF, 6.3V, 20%, 0402	MURATA, GRM155R60J475ME87D
5	5	C16, C17, C18, C22, C23	CAP., X7R, 0.01µF, 10V, 10%, 0402	AVX, 0402ZC103KAT2A
6	2	C38, C39	CAP., COG, 27pF, 50V 5% 0402	TDK, C1005C0G1H270J
7	0	E1, E2, E3, E4, E5	TP, TURRET, 0.064"	MILL-MAX, 2308-2-00-80-00-00-07-0
8	3	FB1, FB2, FB3	FERRITE BEAD, 600Ω AT 100MHz, 0603	MURATA, BLM18HG601SN1D
9	1	J1	BGA CONNECTOR, 40X10	SAMTEC, SEAM-40-02.0-S-10-2-A-K-TR
10	1	J2	HEADER, 2X7, 0.079", HD2X7-79	SULLINS, NRPN072PAEN-RC
11	1	J3	CONN., MINI USB 2.0 TYPE B, RIGHT ANGLE	WE, 651005136521
12	33	R1, R2, R5-R24, R26-R34, R55, R56	RES., CHIP, 49.9Ω, 1/16W, 1%, 0402	YAGEO, RC0402FR-0749R9L
13	0	R3	RES., 0402	OPT
14	4	R4, R41, R60, R62	RES., CHIP, 10k, 1/16W, 5%, 0402	YAGEO, RC0402JR-0710KL
15	7	R25, R35-R39, R64	RES., CHIP, 0Ω, 0402	YAGEO, RC0402JR-070RL
16	1	R40	RES., CHIP, 14.3k, 1/16W, 1% 0402	YAGEO, RC0402FR-0714K3L
17	12	R42-R53	RES., CHIP, 1k, 1/16W, 5%, 0402	YAGEO, RC0402JR-071KL
18	0	R54	RES., 0402	OPT
19	2	R57, R58	RES., CHIP, 10Ω, 1/16W, 5%, 0402	YAGEO, RC0402JR-0710RL
20	1	R59	RES., CHIP, 15k, 1/16W, 5%, 0402	YAGEO, RC0402JR-0715KL
21	1	R61	RES., CHIP, 12k, 1/16W, 5%, 0402	YAGEO, RC0402JR-0712KL
22	1	R63	RES., CHIP, 2k, 1/16W, 5%, 0402	YAGEO, RC0402JR-072KL
23	1	SW1	SWITCH, SLIDE SPDT 30V 0.2A, THROUGH HOLE	E-SWITCH, EG1218
24	1	U1	I.C., LT1761ES5-SD, TSOT23-5	LINEAR TECH., LT1761ES5-SD
25	1	U2	I.C., QUAD 2:1 SWITCH, TSSOP16	FAIRCHILD SEMI., FST3257MTCX
26	1	U3	I.C., EEPROM 1KBIT 3MHz, TSSOP8	MICROCHIP, 93LC46C-I/ST
27	1	U4	I.C., DUAL HIGH SPEED USB, LQFP64	FTDI, FT2232HL-1000
28	1	U5	I.C., LT1761ES5-3.3, TSOT23-5	LINEAR TECH., LT1761ES5-3.3
29	1	Y1	CRYSTAL, 12.0MHz, SMT	ABRACON, ABMM2-12.000MHZ-E2-T

SCHEMATIC DIAGRAM



SCHEMATIC DIAGRAM

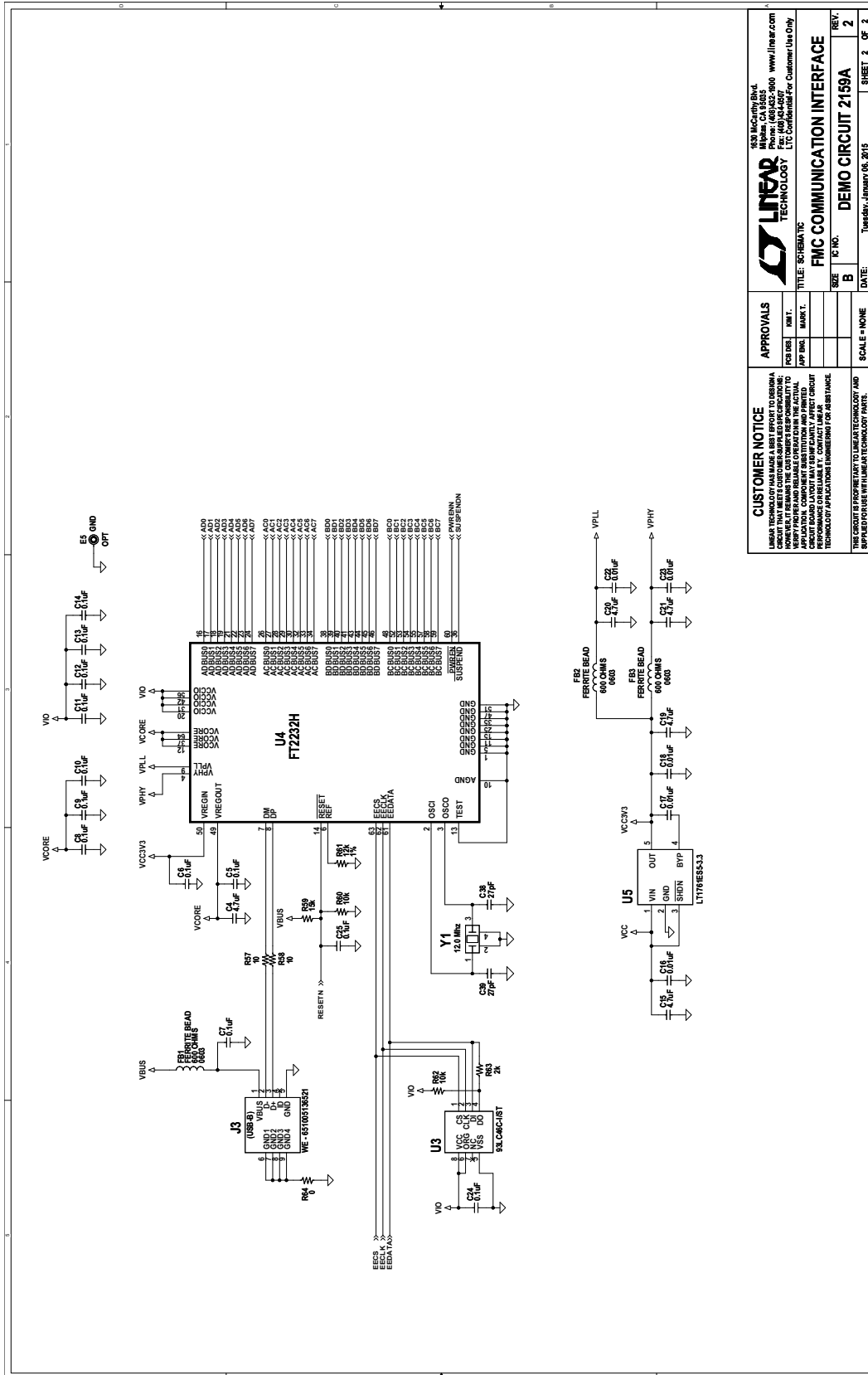

CUSTOMER NOTICE		APPROVALS	
LINEAR TECHNOLOGY HAS MADE A BEST EFFORT TO DESIGN A CIRCUIT THAT MEETS CUSTOMER-SUPPLIED SPECIFICATIONS. WEYFAIR TECHNOLOGY HAS MADE A BEST EFFORT TO DESIGN A CIRCUIT THAT MEETS CUSTOMER-SUPPLIED SPECIFICATIONS. APPLICATIONS ENGINEERS SHOULD CONSULT WITH LINEAR TECHNOLOGY FOR APPLICATION-SPECIFIC DESIGN GUIDANCE. CUSTOMER PERFORMANCE OF THIS CIRCUIT IS THE RESPONSIBILITY OF THE CUSTOMER. CONTACT LINEAR TECHNOLOGY FOR APPLICATIONS ENGINEERING SUPPORT.		DESIGNED BY: _____	SCALE: NONE
LINEAR TECHNOLOGY HAS MADE A BEST EFFORT TO DESIGN A CIRCUIT THAT MEETS CUSTOMER-SUPPLIED SPECIFICATIONS. WEYFAIR TECHNOLOGY HAS MADE A BEST EFFORT TO DESIGN A CIRCUIT THAT MEETS CUSTOMER-SUPPLIED SPECIFICATIONS. APPLICATIONS ENGINEERS SHOULD CONSULT WITH LINEAR TECHNOLOGY FOR APPLICATION-SPECIFIC DESIGN GUIDANCE. CUSTOMER PERFORMANCE OF THIS CIRCUIT IS THE RESPONSIBILITY OF THE CUSTOMER. CONTACT LINEAR TECHNOLOGY FOR APPLICATIONS ENGINEERING SUPPORT.		DATE: _____	SHEET 2 OF 2
LINEAR TECHNOLOGY		FMC COMMUNICATION INTERFACE	
1630 Broadway Blvd. Folsom, CA 95630 Tel: (916) 434-2000 Fax: (916) 434-2007 LTC Confidential For Customer Use Only		REV. 2	
TITLE: SCHEMATIC		DATE: Tuesday, January 04, 2011	
SIZE: B		SHEET 2 OF 2	
IC NO. _____		REV. 2	
DATE: _____		SHEET 2 OF 2	



Information furnished by Linear Technology Corporation is believed to be accurate and reliable. However, no responsibility is assumed for its use. Linear Technology Corporation makes no representation that the interconnection of its circuits as described herein will not infringe on existing patent rights.