

Programmable Six Channel Sequencer and Voltage Supervisor with EEPROM

FEATURES

- Time and Event Based Sequencing
- 12 Programmable Undervoltage (UV) and Overvoltage (OV) Comparators: $\pm 0.75\%$ Accuracy
- I²C/SMBus Interface
- Stalled Power Supply Detection
- Single Wire Synchronization Allows Controller Expansion to 50 Devices (300 Power Supplies)
- Configuration and Fault Logging in EEPROM
- EEPROM Specified Over Entire Temperature Range, Rated to 125°C, 10k Writes, 20yr Retention
- Supported by LTpowerPlay® GUI
- Fault and System Status Registers
- Reset Output with Programmable Delay
- Wide Input Supply Voltage Range: 2.9V to 16.5V
- 28-Lead QFN (5mm × 6mm) Package

APPLICATIONS

- Network Servers
- Data Storage Systems
- Telecom Equipment
- High Availability Computer Systems

DESCRIPTION

The LTC2937 is a 6-channel power supply sequencer and voltage supervisor. Supplies are enabled or disabled with precise user controlled order and time spacing. To detect power supply output faults during sequencing and monitoring, the LTC2937 accurately monitors supply turn-on/-off delays and output voltage levels. In the event of a fault, response actions include complete power supply shutdown and optional restarts. Root cause of power faults are logged to EEPROM. For systems with high supply count, a simple single wire connection between multiple LTC2937 devices allows sequencing expansion to 300 supplies. After successful sequencing and supply voltage stabilization, the reset output pulls high to initiate microprocessor or other system activity. To accommodate supply margin testing, the reset output can be disabled. Upon supply turn-off, integrated current sources are available as needed to discharge slowly decaying supplies. Configuration EEPROM supports autonomous operation without software.

All registered trademarks and trademarks are the property of their respective owners. Protected by U.S. Patents including 8627132.

TYPICAL APPLICATION

Six Power Supply Sequencer and Supervisor

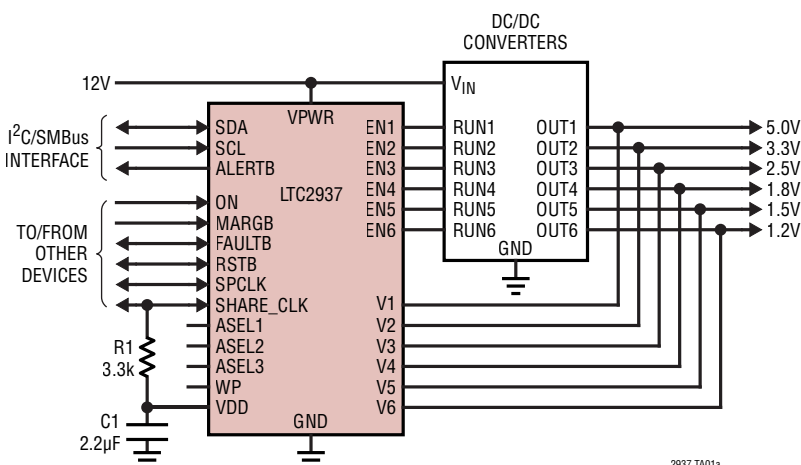

Sequenced Power Supply Waveforms

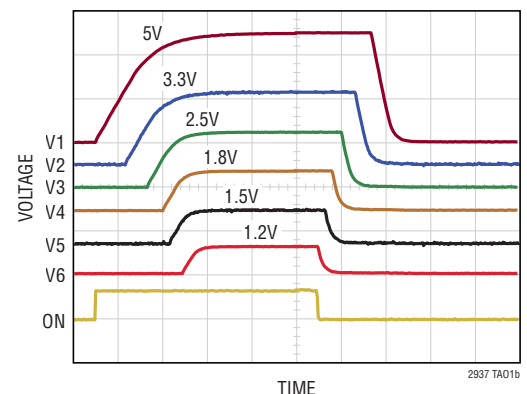

TABLE OF CONTENTS

| | | | |
|---|-----------|---|-----------|
| Features | 1 | MONITOR_STATUS | 34 |
| Applications | 1 | DEVICE_ID | 34 |
| Typical Application | 1 | Applications Information | 35 |
| Description | 1 | Introduction | 35 |
| Absolute Maximum Ratings | 3 | Powering the LTC2937..... | 35 |
| Order Information | 3 | Write Protection..... | 35 |
| Pin Configuration | 3 | Updating Volatile or Nonvolatile Memory..... | 35 |
| Electrical Characteristics | 4 | Sequence Position Clock (SPCLK)..... | 36 |
| Serial Bus Timing Diagram | 7 | System Configuration | 37 |
| Sequence-Up Threshold Timing Diagram | 7 | Sequence-Up and Sequence-Down Control..... | 37 |
| Sequence-Down Event Based Timing Diagram | 8 | Sequence-Up Parameters | 38 |
| Sequence-Down Time Based Timing Diagram | 9 | Voltage Supervision..... | 38 |
| Typical Performance Characteristics | 10 | Voltage Monitor Range | 38 |
| Pin Functions | 12 | UV and OV Thresholds..... | 39 |
| Block Diagram | 13 | UV Thresholds and Sequence-Up Hysteresis..... | 39 |
| Operation | 14 | Selecting Resistors for Adjustable Range | 39 |
| Slave Addresses | 15 | OV Thresholds in Adjustable Applications | 40 |
| I ² C Interface | 16 | RSTB Response..... | 41 |
| Condensed Command Summary | 17 | Sequence-Down Parameters | 41 |
| Command Descriptions | 18 | Discharge Thresholds..... | 42 |
| WRITE_PROTECTION | 18 | Active Supply Discharge | 42 |
| SPECIAL_LOT..... | 18 | Fault Descriptions | 43 |
| ON_OFF_CONTROL..... | 19 | CONTROL Faults | 43 |
| V_RANGE | 20 | SEQUENCE Faults | 43 |
| V_THRESHOLD_n..... | 21 | SUPERVISOR Faults | 43 |
| Voltage Threshold Encoding | 21 | EXTERNAL Faults | 43 |
| TON_TIMERS_n..... | 22 | SHARE_CLK Faults | 43 |
| TOFF_TIMERS_n..... | 23 | Fault Reporting | 44 |
| SEQ_UP_POSITION_n | 24 | Fault Management | 44 |
| SEQ_DOWN_POSITION_n..... | 25 | Fault Debugging Tools | 46 |
| RSTB_CONFIG | 26 | Share Clock (SHARE_CLK) | 46 |
| FAULT_RESPONSE | 27 | Asynchronous Supply Control | 46 |
| MONITOR_STATUS_HISTORY..... | 29 | LTpowerPlay: An Interactive GUI for Power System Management..... | 47 |
| CLEAR_ALERTB | 30 | External Connection Design Checklist | 47 |
| STORE | 30 | Minimum Connections for Programming..... | 48 |
| RESTORE..... | 30 | Interconnect Between Multiple LTC2937s..... | 48 |
| CLEAR | 30 | System Event Based Sequencing..... | 48 |
| STATUS_INFORMATION | 31 | Package Description | 50 |
| BREAK_POINT..... | 32 | Revision History | 51 |
| SEQ_POSITION_COUNT | 32 | Typical Application | 52 |
| MONITOR_BACKUP..... | 33 | Related Parts | 52 |

ABSOLUTE MAXIMUM RATINGS

(Notes 1, 2)

| | |
|---|----------------|
| VPWR | -0.3V to 18V |
| EN1, EN2, EN3, EN4, EN5, EN6 | -0.3V to 16V |
| VDD, ALERTB, FAULTB, MARGB, RSTB, ON, SCL, SDA, SHARE_CLK, SPCLK, WP, V1, V2, V3, V4, V5, V6..... | -0.3V to 6V |
| ASEL1, ASEL2, ASEL3..... | -0.3V to VDD |
| Input Currents | |
| V1, V2, V3, V4, V5, V6..... | -1mA |
| Operating Junction Temperature Range | |
| LTC2937C | 0°C to 70°C |
| LTC2937I | -40°C to 85°C |
| LTC2937H..... | -40°C to 125°C |
| LTC2937MP | -55°C to 125°C |
| Storage Temperature Range | -65°C to 150°C |
| Maximum Junction Temperature | 130°C |

PIN CONFIGURATION

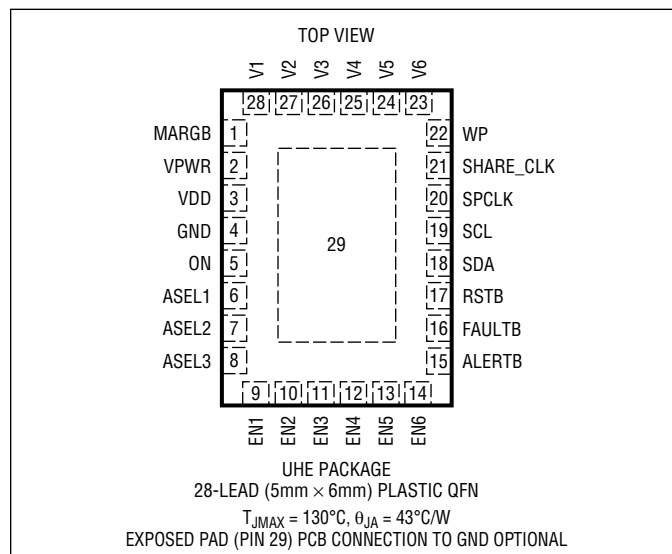

ORDER INFORMATION

| LEAD FREE FINISH | TAPE AND REEL | PART MARKING* | PACKAGE DESCRIPTION | TEMPERATURE RANGE |
|------------------|--------------------|---------------|---------------------------------|-------------------|
| LTC2937CUHE#PBF | LTC2937CUHE#TRPBF | 2937 | 28-Lead (5mm × 6mm) Plastic QFN | 0°C to 70°C |
| LTC2937IUHE#PBF | LTC2937IUHE#TRPBF | 2937 | 28-Lead (5mm × 6mm) Plastic QFN | -40°C to 85°C |
| LTC2937HUHE#PBF | LTC2937HUHE#TRPBF | 2937 | 28-Lead (5mm × 6mm) Plastic QFN | -40°C to 125°C |
| LTC2937MPUHE#PBF | LTC2937MPUHE#TRPBF | 2937 | 28-Lead (5mm × 6mm) Plastic QFN | -55°C to 125°C |

Contact the factory for parts specified with wider operating temperature ranges. *The temperature grade is identified by a label on the shipping container.

[Tape and reel specifications](#). Some packages are available in 500 unit reels through designated sales channels with #TRMPBF suffix.

ELECTRICAL CHARACTERISTICS

The ● denotes the specifications which apply over the full operating temperature range, otherwise specifications are at $T_A = 25^\circ\text{C}$ and $VPWR = 12\text{V}$. (Note 2)

| SYMBOL | PARAMETER | CONDITIONS | MIN | TYP | MAX | UNITS | |
|-------------------------------|---|--|--------------------------------------|---|--|---|--|
| Device Power | | | | | | | |
| V_{VPWR} | VPWR Supply Input Operating Range | | ● | 4.5 | 16.5 | V | |
| I_{VPWR} | VPWR Supply Current | Sequencing Complete, No VDD Load Writing to EEPROM | ● | | 1 | mA | |
| | | | ● | | 3 | mA | |
| V_{DDREG} | VDD Regulated Output | $VPWR \geq 4.5\text{V}$, $I_{VDD} = -1\text{mA}$ | ● | 3.234 | 3.3 | 3.366 | V |
| V_{OP} | VDD Operating Range | VDD Connected to VPWR | ● | 2.9 | 5.5 | V | |
| V_{UVL} | VDD Undervoltage Lockout | VDD Rising | ● | 2.5 | 2.7 | 2.85 | V |
| $V_{UVL(HYST)}$ | VDD Undervoltage Lockout Hysteresis | VDD Falling | | | 75 | mV | |
| V1, V2, V3, V4, V5, V6 | | | | | | | |
| V_{MON} | V_n Monitoring Thresholds ($n = 1$ through 6) (Note 3) | Adjustable Range Low Range High Range | ● ● ● | 0.2 0.5 1 | 1.2 3 6 | V V V | |
| V_{RES} | V_n Threshold Programming LSB Resolution | Adjustable Range Low Range High Range | | | 4 10 20 | mV mV mV | |
| $V_{MON(ACC)}$ | V_n Threshold Accuracy by Code (Note 4) | C-, I-Grades: Codes 155 to 255 Codes 55 to 154 Codes 5 to 54 H-, MP-Grades: Codes 155 to 255 Codes 55 to 154 Codes 5 to 54 | ● ● ● ● ● ● ● | | ± 0.75 ± 0.75 ± 1.5 ± 1 ± 1 ± 1.5 | % % % % % % | |
| $V_{MON(HYST)}$ | Temporary Sequence-Up Threshold Hysteresis (Note 5) | Sequence Up Threshold Achieved | ● | -4 | -5 | -6 | % |
| t_{PD} | V_n Comparator Propagation Delay | 2 LSB Overdrive of Configured Threshold 10 LSB Overdrive of Configured Threshold | ● | | 35 10 | μs μs | |
| R_{IN} | V_n Input Resistance | Low Range and High Range | ● | 400 | 600 | 900 | k Ω |
| I_{LKG} | V_n Input Leakage Current | Adjustable Range, $V = 1.2\text{V}$ | ● | | ± 15 | nA | |
| R_{ON} | V_n Discharge On Resistance | $V = 0.4\text{V}$ | ● | 25 | 40 | 50 | Ω |
| $I_{AD(MAX)}$ | V_n Discharge Current | $V = 1.8\text{V}$ | ● | 20 | 35 | 45 | mA |
| V_{DTH} | V_n Discharge Threshold | High and Low Range Adjustable Range (Positive Polarity) Adjustable Range (Negative Polarity) | ● ● ● | 300 50 1.12 | 400 120 1.2 | 500 190 1.28 | mV mV V |
| EEPROM | | | | | | | |
| | Retention | (Notes 6, 7) | ● | 20 | | Years | |
| | Endurance | 1 Cycle = 1 STORE Command (Notes 6, 7) | ● | 10,000 | | Cycles | |
| t_{PT} | Programming Time (Note 8) | STORE Command | ● | | 130 | ms | |
| t_{RT} | Restore Time | RESTORE Command | ● | | 2 | ms | |
| RSTB | | | | | | | |
| t_{RST} | Programmable Reset Delay (Register 0x22, RSTB_CONFIG) | b[15:13] = 000b b[15:13] = 001b b[15:13] = 010b b[15:13] = 011b b[15:13] = 100b b[15:13] = 101b b[15:13] = 110b b[15:13] = 111b | ● ● ● ● ● ● ● ● | 0 1.4 5.8 22 46 180 370 1480 | 0.05 1.6 6.4 26 51 200 410 1640 | 0.1 1.9 7.5 30 60 230 475 1900 | ms ms ms ms ms ms ms ms |

ELECTRICAL CHARACTERISTICS

The ● denotes the specifications which apply over the full operating temperature range, otherwise specifications are at $T_A = 25^\circ\text{C}$ and $V_{PWR} = 12\text{V}$. (Note 2)

| SYMBOL | PARAMETER | CONDITIONS | MIN | TYP | MAX | UNITS | |
|-------------------------------|--|--|--------------------------------------|--|--|---|---|
| Sequence Timers | | | | | | | |
| t_{ON_MAX} | ton_max time (Registers 0x0A through 0x0F) | b[15:13] = 000b b[15:13] = 001b b[15:13] = 010b b[15:13] = 011b b[15:13] = 100b b[15:13] = 101b b[15:13] = 110b b[15:13] = 111b | ● ● ● ● ● ● ● ● | ∞ 136 540 2.2 8.7 35 140 560 | ∞ 160 640 2.6 10.2 41 164 655 | ∞ 195 780 3.2 12.4 50 200 800 | s μs μs ms ms ms ms ms ms |
| t_{OND} | ton_delay Time (Registers 0x0A through 0x0F) | Timer Register Value N = b[12:0] | ● | $68 \cdot N$ | $80 \cdot N$ | $96 \cdot N$ | μs |
| t_{OFF_MAX} | toff_max Time (Registers 0x10 through 0x15) | b[15:13] = 000b b[15:13] = 001b b[15:13] = 010b b[15:13] = 011b b[15:13] = 100b b[15:13] = 101b b[15:13] = 110b b[15:13] = 111b | ● ● ● ● ● ● ● ● | ∞ 2.2 8.7 35 140 560 2.3 9 | ∞ 2.6 10.2 41 164 655 2.6 10.5 | ∞ 3.2 12.4 50 200 800 3.2 13 | s ms ms ms ms ms s s |
| t_{OFFD} | toff_delay Time (Registers 0x10 through 0x15) | Timer Register Value N = b[12:0] | ● | $68 \cdot N$ | $80 \cdot N$ | $96 \cdot N$ | μs |
| SPCLK | | | | | | | |
| t_{ON_SQ} | ON Input to Start of SPCLK | (Note 9) | ● | 40 | 80 | 120 | μs |
| I_{PU} | SPCLK Pull-Up Current | $V_{SPCLK} = \text{GND}$ | ● | -30 | -55 | -80 | μA |
| t_{LO} | Minimum SPCLK Low Time | | ● | 16 | 20 | 26 | μs |
| t_{HI} | Minimum SPCLK High Time | | ● | 48 | 60 | 75 | μs |
| t_{FLOAT} | SPCLK Float High Time | End of Sequencing | ● | 260 | 320 | 400 | μs |
| SHARE_CLK | | | | | | | |
| f_{SHR} | Share Clock Frequency | | ● | 85 | 100 | 110 | kHz |
| Analog and Digital I/O | | | | | | | |
| V_{TH} | Input Threshold: ON, MARGB, WP, RSTB, FAULTB, SHARE_CLK, SPCLK | | ● | 1 | 1.2 | 1.4 | V |
| $V_{TH(HYST)}$ | Input Threshold Hysteresis: ON, MARGB, WP, RSTB, FAULTB, SHARE_CLK, SPCLK | | | | 50 | | mV |
| V_{OL} | Voltage Output Low: ALERTB, RSTB, FAULTB, SHARE_CLK, SPCLK, EN1, EN2, EN3, EN4, EN5, EN6 | $I_{SINK} = 3\text{mA}$ | ● | | 0.2 | 0.4 | V |
| I_{PU} | Internal Pull-Up Current: ON, MARGB, WP, ALERTB, RSTB, FAULTB | $V = \text{GND}$ | ● | -4 | -10 | -16 | μA |

ELECTRICAL CHARACTERISTICS

The ● denotes the specifications which apply over the full operating temperature range, otherwise specifications are at $T_A = 25^\circ\text{C}$ and $V_{PWR} = 12\text{V}$. (Note 2)

| SYMBOL | PARAMETER | CONDITIONS | MIN | TYP | MAX | UNITS |
|----------|--|---------------------------------------|-----|--------------|--------------------|--------------------------------|
| | Leakage Current: ALERTB, RSTB, FAULTB Leakage Current: EN1, EN2, EN3, EN4, EN5, EN6 | $V = 5.5\text{V}$ $V = 15\text{V}$ | ● | | ± 1 ± 1 | μA μA |
| V_{OH} | Voltage Output High: ALERTB, RSTB, FAULTB | $I_{SOURCE} = -1\mu\text{A}$ | ● | $V_{DD} - 1$ | | V |
| t_{PW} | Minimum Detectable Pulse Width: ON, FAULTB | | ● | 25 | | μs |

Serial Bus Interface and Address Inputs

| | | | | | | | |
|-----------------|---|------------------------|---|--------------------|--------------------|---------------|------------------|
| $V_{ASEL(H)}$ | ASEL Input High Threshold | | ● | $V_{DD} - 0.4$ | | V | |
| $V_{ASEL(L)}$ | ASEL Input Low Threshold | | ● | | 0.4 | V | |
| $V_{ASEL(OC)}$ | ASEL Open Circuit Voltage | | | $0.5 \cdot V_{DD}$ | | V | |
| $V_{ASEL(OCR)}$ | ASEL Allowable Open Circuit Voltage Range | | ● | $0.4 \cdot V_{DD}$ | $0.6 \cdot V_{DD}$ | V | |
| $I_{ASEL(HZ)}$ | Allowable Leakage in Open State | | ● | | ± 1 | μA | |
| | ASEL Input Resistance | | ● | 120 | 180 | 280 | $\text{k}\Omega$ |
| V_{STH} | SDA, SCL Input Threshold | | ● | 1.5 | 1.8 | 2 | V |
| I_{STH} | SDA, SCL Input Current | SDA or SCL = 5.5V | ● | | 0 | ± 2 | μA |
| $V_{SDA(OL)}$ | SDA Output Low Voltage | $I_{SDA} = 3\text{mA}$ | ● | | 0.3 | 0.4 | V |

Serial Bus Timing (Note 10)

| | | | | | | | |
|-------------------|--------------------------------------|-----------------------------|---|-----|--|-----|---------------|
| $f_{SCL(MIN)}$ | Minimum Serial Clock Frequency | | ● | | | 10 | kHz |
| $f_{SCL(MAX)}$ | Maximum Serial Clock Frequency | | ● | 400 | | | kHz |
| $t_{LOW(MIN)}$ | Serial Clock Low Period | | ● | | | 1.3 | μs |
| $t_{HIGH(MIN)}$ | Serial Clock High Period | | ● | | | 0.6 | μs |
| $t_{BUF(MIN)}$ | Bus Free Time Between Stop and Start | | ● | | | 1.3 | μs |
| $t_{HD,STA(MIN)}$ | Start Condition Hold Time | | ● | | | 600 | ns |
| $t_{SU,STA(MIN)}$ | Start Condition Setup Time | | ● | | | 600 | ns |
| $t_{SU,STO(MIN)}$ | Stop Condition Setup Time | | ● | | | 600 | ns |
| $t_{HD,DAT(MIN)}$ | Data Hold Time | (LTC2937 Receiving Data) | ● | | | 0 | ns |
| $t_{HD,DAT}$ | Data Hold Time | (LTC2937 Transmitting Data) | ● | 300 | | 900 | ns |
| $t_{SU,DAT(MIN)}$ | Data Setup Time | | ● | | | 100 | ns |

Note 1: Stresses beyond those listed under Absolute Maximum Ratings may cause permanent damage to the device. Exposure to any Absolute Maximum Rating condition for extended periods may affect device reliability and lifetime.

Note 2: All currents into device pins are positive. All currents out of device pins are negative. All voltages are referenced to GND unless otherwise specified.

Note 3: Subscript (or placeholder) n denotes a channel number and is applied throughout this document.

Note 4: Threshold codes 0 through 4 are not used.

Note 5: During sequence-up operation, undervoltage comparators participating in sequencing receive a temporary 5% hysteresis after the respective monitored voltage exceeds its threshold for the first time. The hysteresis remains active until 50% of the programmed reset delay time

has been completed. See the timing diagram and applications information for more details.

Note 6: EEPROM endurance and retention are guaranteed by design, characterization and correlation with statistical process controls.

Note 7: EEPROM endurance and retention will be degraded when $T_J > 85^\circ\text{C}$.

Note 8: The LTC2937 will not acknowledge any commands while a STORE command is being executed.

Note 9: If multiple LTC2937s are in use, t_{ONSQ} can stretch indefinitely until all devices are ready to sequence.

Note 10: Maximum capacitive load, C_B , for SCL and SDA is 400pF. Data and clock rise time (t_r) and fall time (t_f) are: $(20 + 0.1 \cdot C_B)$ (ns) $< t_r < 300\text{ns}$ and $(20 + 0.1 \cdot C_B)$ (ns) $< t_f < 300\text{ns}$. C_B = capacitance of one bus line in pF. SCL and SDA external pull-up voltage, V_{IO} , is $2.9\text{V} < V_{IO} < 5.5\text{V}$.

SERIAL BUS TIMING DIAGRAM

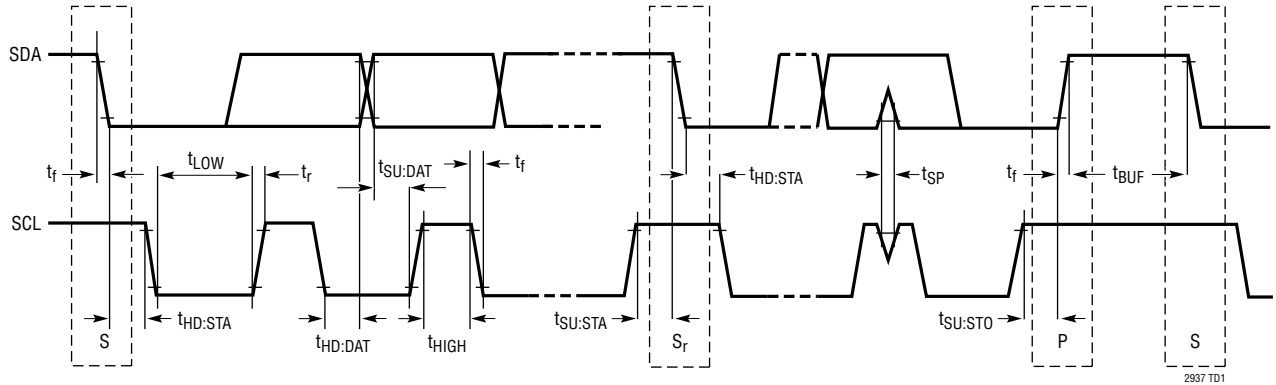

SEQUENCE-UP THRESHOLD TIMING DIAGRAM

Sequencing 2 Channels (V1, V2), Both Combined into RSTB Logic

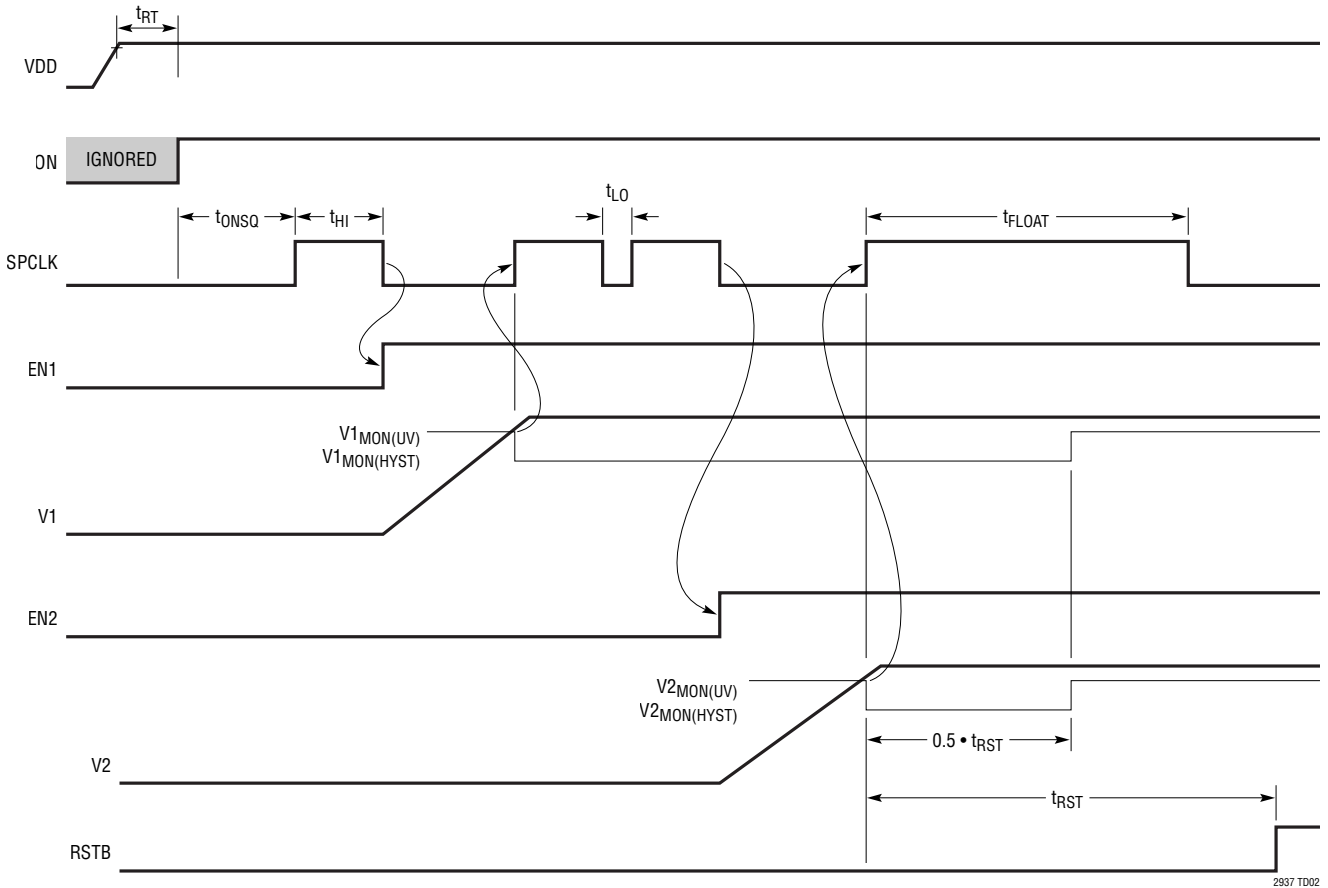

SEQUENCE-DOWN EVENT BASED TIMING DIAGRAM

Sequencing 2 Channels (V1, V2), Both Combined into RSTB Logic

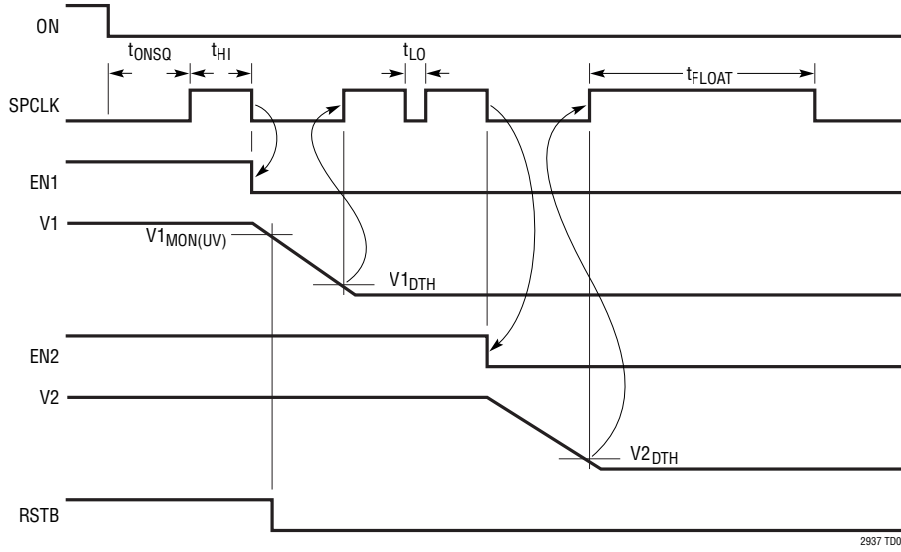

SEQUENCE-DOWN TIME BASED TIMING DIAGRAM

Sequencing 2 Channels (V1, V2), Both Combined into RSTB Logic. toff_max Timers Used for Post Disable Sequencing Delay; ON_OFF_CONTROL b[0] = 1

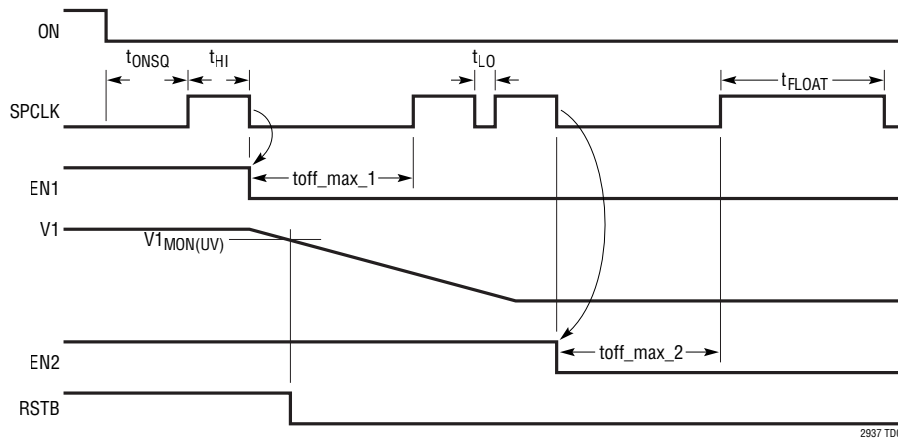

TYPICAL PERFORMANCE CHARACTERISTICS

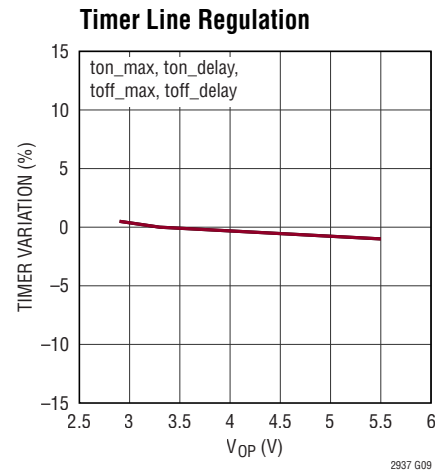
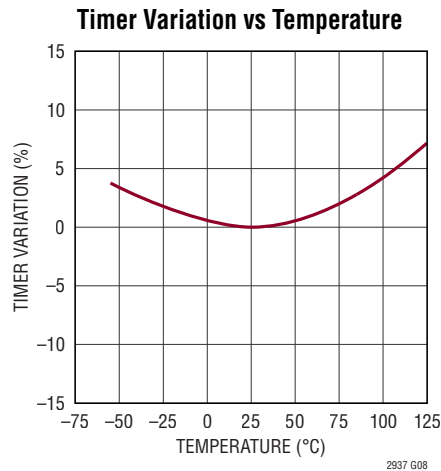
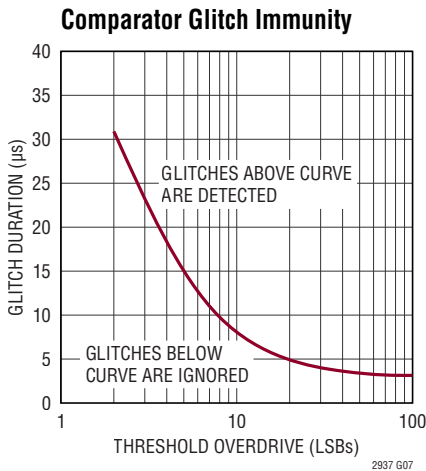
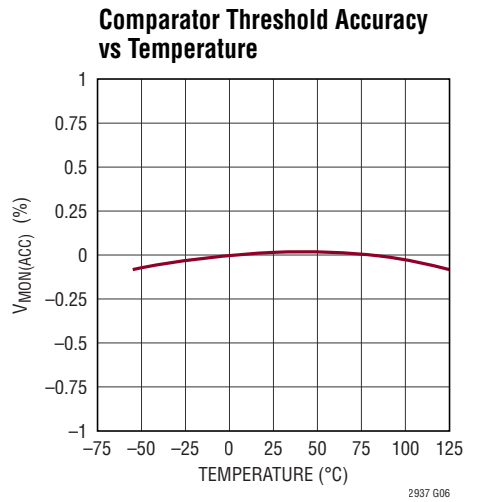
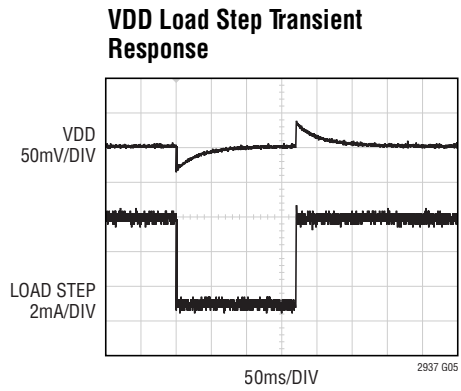
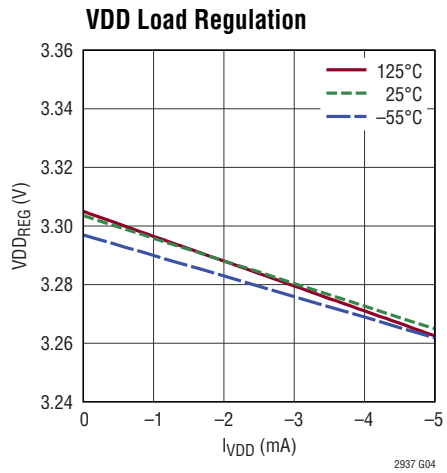
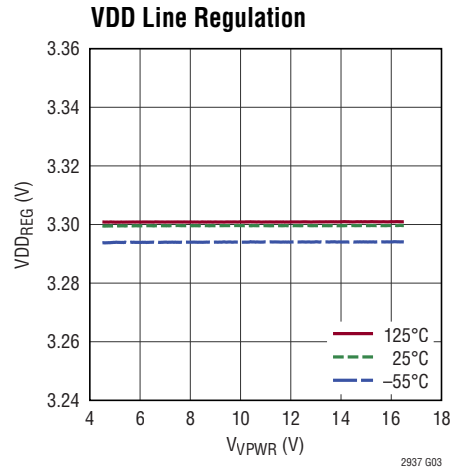
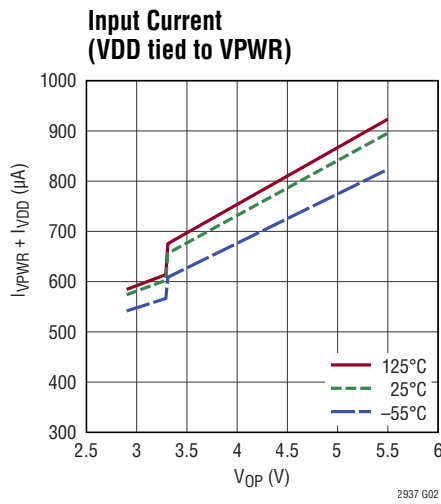
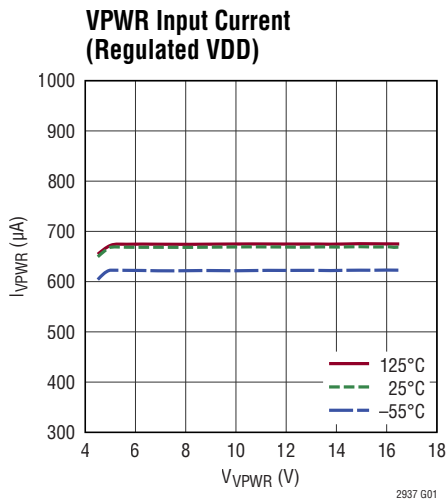

TYPICAL PERFORMANCE CHARACTERISTICS

**V_{OL} vs Output Sink Current
RSTB, FAULTB, ALERTB**

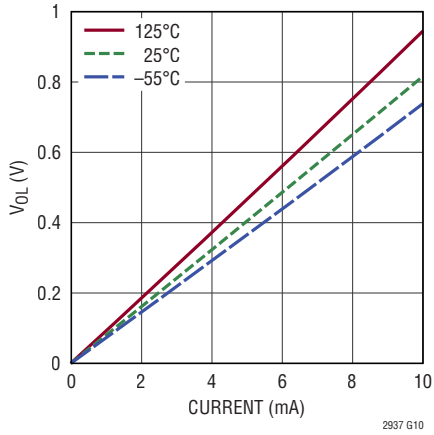

EN/nV_{OL} vs Output Sink Current

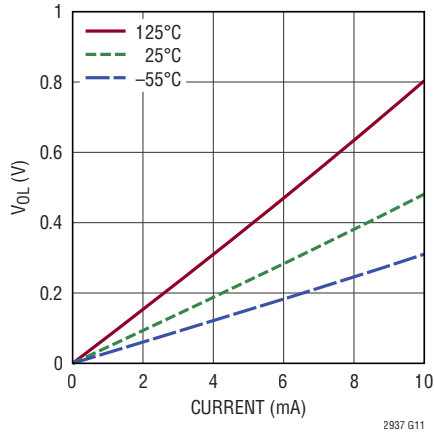

ASEL/n Current vs Input Voltage

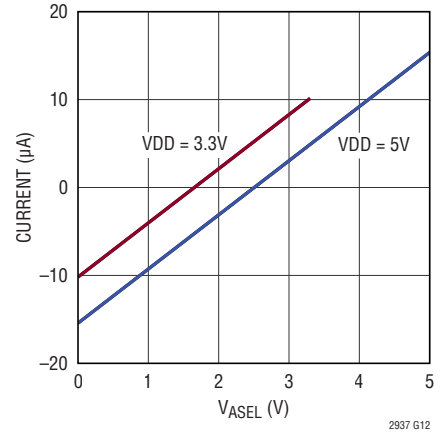

SHARE_CLK Frequency vs Temperature

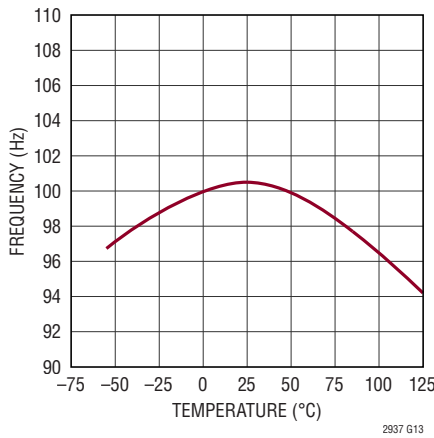

SHARE_CLK Frequency Line Regulation

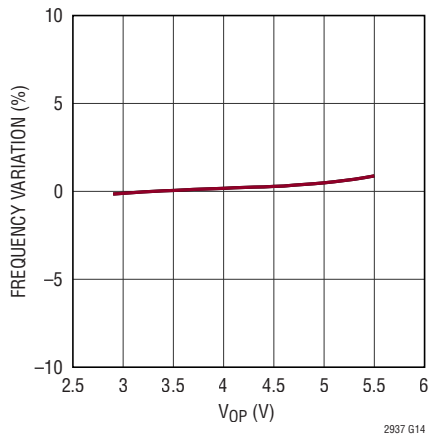

Reset Delay Variation vs Temperature

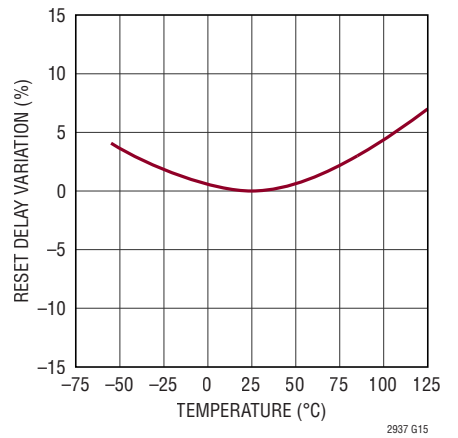

Active Discharge Current vs Monitor Input Voltage

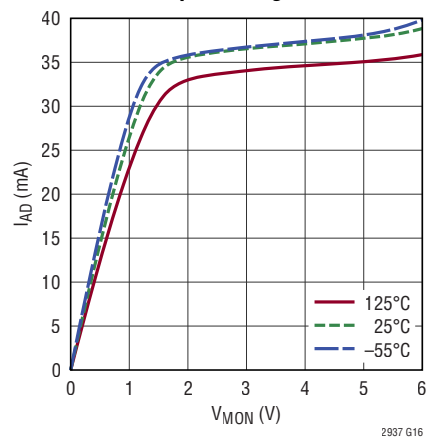

Discharge Threshold Variation vs Temperature

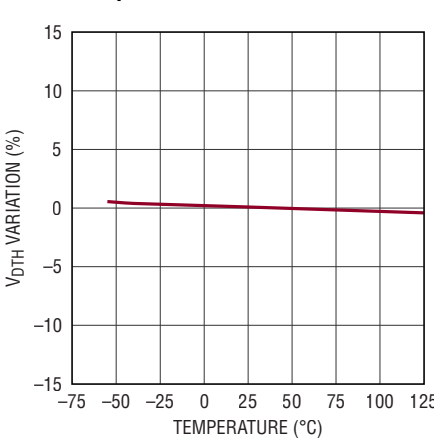

RSTB (Low) vs VDD

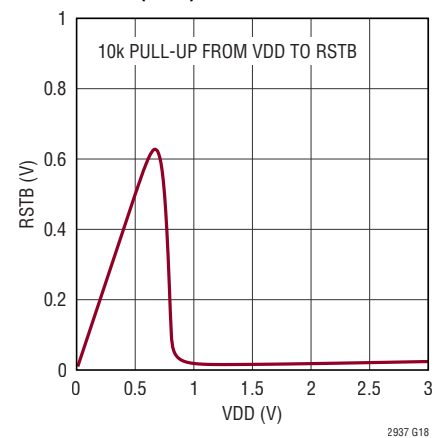

PIN FUNCTIONS

ALERTB: Alert Open-Drain Output with 10 μ A Pull-Up to VDD. Asserts low in response to any designated fault. Conforms to SMBus standard. Apply the Alert Response Protocol to clear the ALERTB output and to identify the alerting device. Performing a read from the CLEAR_ALERTB register will also remove ALERTB pull-down.

ASEL1, ASEL2, ASEL3: Three-State Address-Select Inputs. Connect to GND, VDD or open to encode 1 of 27 device addresses. Consult the Operation section for the address look-up table.

EN1, EN2, EN3, EN4, EN5, EN6: Power Supply Enable Outputs. Connect these open-drain outputs to a respective power supply enable input or to a gate of an N-channel MOSFET (for pass applications). The enable outputs must be pulled up externally (to a maximum of 15V) if necessary. Some power supply enable inputs have internal pull-up sources, which eliminates the need for an external pull-up.

Exposed Pad: Leave open or connect to device GND.

FAULTB: Fault I/O with 10 μ A Pull-Up to VDD. Asserts low in response to any designated fault. Configure fault behavior in the FAULT_RESPONSE register. External devices may also pull down on FAULTB to initiate an optional fault response.

GND: Device Ground.

MARGB: Margin Input. Pull to ground to disable RSTB and prevent SUPERVISOR faults. Typically applied prior to margining supplies high or low during system test. Leave open or pull to VDD when not margining.

ON: Sequencing Up/Down Control Input. ON input response is gated by settings in the ON_OFF_CONTROL register. Internally pulled up to VDD with 10 μ A current source.

RSTB: Reset I/O with 10 μ A Pull-Up to VDD. Pulls low in response to designated voltage comparator violations. Pulls high when selected voltage sense thresholds are satisfied (ie not UV and/or not OV), and can be used as a system power-on-reset. The reset assertion delay after satisfying thresholds is programmable. May be pulled low by external devices and detected with b[12] of the MONITOR_STATUS command.

SCL: Serial Clock Input (400kHz Maximum). Requires external pull-up resistor.

SDA: Bidirectional Serial Data I/O. Requires external pull-up resistor.

SHARE_CLK: Clock Sharing Node. Connect multiple SHARE_CLK nodes together to establish a common time base between devices. Pull-up with a 3.3k to 10k resistor to VDD.

SPCLK: Sequence Position Clock I/O. Connect multiple LTC2937 SPCLK lines together for automatic sequence position control between devices. Pull-up devices are not recommended. Leave unconnected in a single device application. Minimize capacitance on this line to ensure reliable operation.

V1, V2, V3, V4, V5, V6: Undervoltage, Overvoltage and Discharge Comparator Inputs. There are three sense ranges. Adjustable: 0.2V to 1.2V in 4mV increments, Low: 0.5V to 3V in 10mV increments, and High: 1V to 6V in 20mV increments. When monitored supplies are shut off, internal pull-down current sources can be activated to accelerate the discharge of supply capacitance. Connect to device GND if unused.

VDD: 3.3V Internal Regulator Output. Bypass with a 2.2 μ F (or greater) capacitor to GND. Use this output to bias the address inputs or an external resistor network for sensing negative supply voltages. Do not load the regulated output with more than 5mA. Override the regulated output with an external supply (2.9V to 5.5V) connected to VPWR and VDD.

VPWR: Supply Voltage Input. Power supply operating range is 4.5V to 16.5V. Tie to VDD if unused. Bypass with 0.1 μ F (or greater) capacitor to GND.

WP: Write Protection Input. Pull to GND to enable write capability into the device. Leave open or tie to VDD to keep write protection active. The software controlled lock bit in the WRITE_PROTECTION register may also need deactivation to enable write capability.

BLOCK DIAGRAM

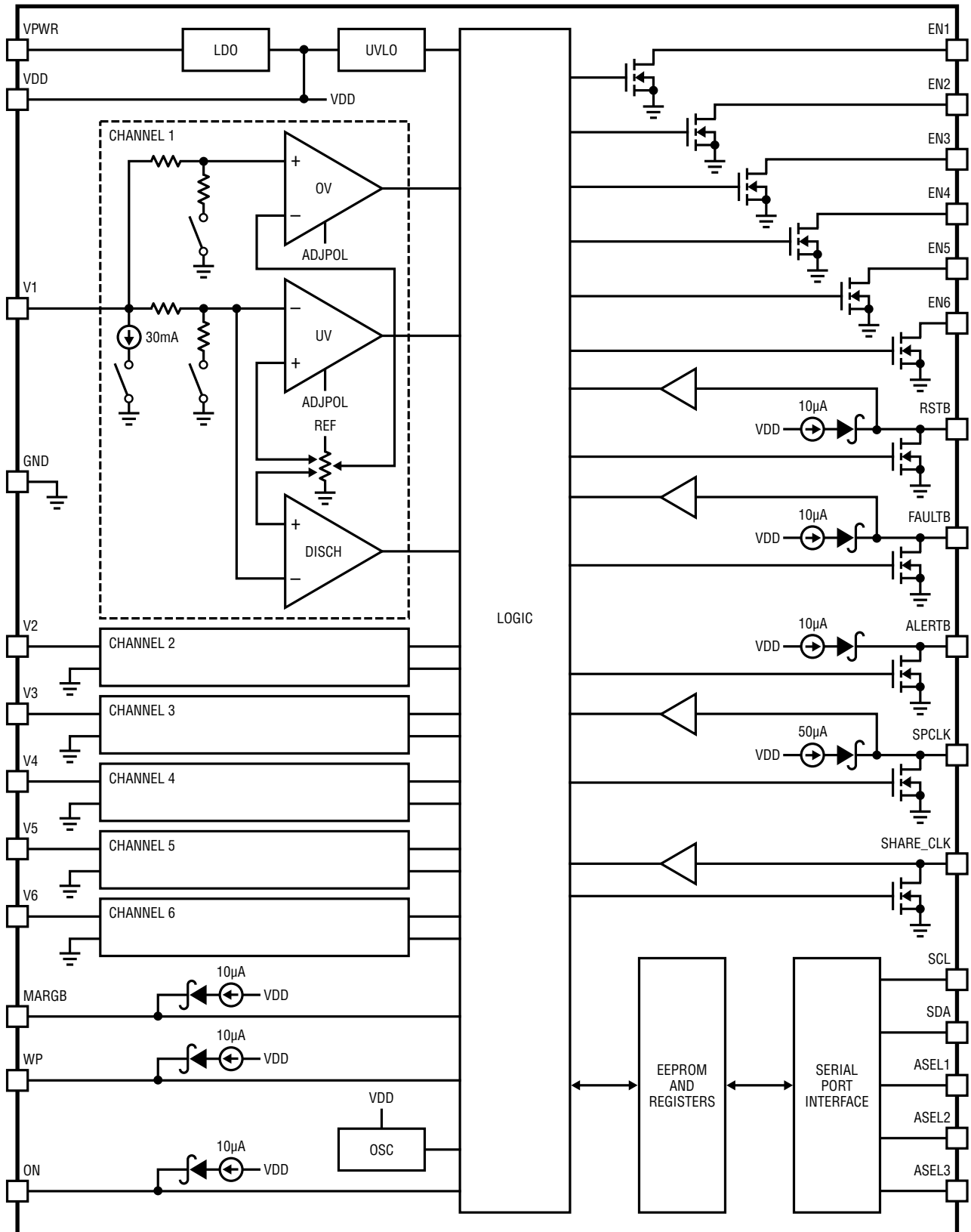

OPERATION

The LTC2937 is a six-channel programmable power supply sequencer and supervisor that can perform the following operations:

- Control the timing relationships and sequence order for six power supplies per device. Sequence supplies on the basis of time delays and/or qualifying events.
- Monitor power supplies for undervoltage (UV) and overvoltage (OV) conditions using two independent comparators on each of six inputs.
- Generate a system reset that is a function of user selected inputs with a programmable release delay.
- Synchronize sequencing across multiple controllers with a one wire connection (SPCLK).
- Synchronize timing across multiple controllers with a one wire connection (SHARE_CLK).
- Discharge slowly decaying supplies with built-in pull-down current sources.
- Monitor power supplies for discharge condition using the discharge comparators.
- Accept I²C/SMBus programming commands.
- Initiate supply sequencing from an external source and/or programming command.
- Retrieve real-time system status.
- Generate a fault related interrupt on the ALERTB output and respond to an issued SMBus Alert Response.
- Respond to fault conditions by continuing operation indefinitely or disabling supplies immediately. Optionally, sequencing may be retried multiple times automatically (0 to 6 or unlimited) after a supply shutdown event.
- Report voltage and/or timing limit violations upon request.
- Pause sequencing operations to help identify system power problems.
- Store system configuration to EEPROM.
- Restore EEPROM contents to operating memory through programming or when VDD is applied on power-up.
- Recall first fault violations logged to EEPROM.
- EEPROM reads and writes over the entire specified supply voltage and temperature range.
- Provide two stage write protection to prevent inadvertent writes to memory.
- Disable system reset when performing voltage margining of supplies.
- Monitor negative power supplies.

OPERATION

Slave Addresses

The LTC2937 responds to one of 27 addresses. Connect the ASEL1, ASEL2 and ASEL3 inputs to VDD, GND, or leave open, as shown in Table 1. The LTC2937 always responds to the Global and Alert Response addresses regardless of the ASEL input states. The ASEL inputs are always active and operate in real time.

Table 1. LTC2937 Address Look-Up Table

| DESCRIPTION | HEX DEVICE ADDRESS | | BINARY DEVICE ADDRESS | | | | | | | | R/W | ADDRESS INPUTS | | |
|----------------|--------------------|-------|-----------------------|---|---|---|---|---|---|-------|-----|----------------|-------|--|
| | 7-Bit | 8-Bit | 6 | 5 | 4 | 3 | 2 | 1 | 0 | ASEL3 | | ASEL2 | ASEL1 | |
| Alert Response | 0C | 19 | 0 | 0 | 0 | 1 | 1 | 0 | 0 | 1 | X | X | X | |
| Global | 36 | 6C | 0 | 1 | 1 | 0 | 1 | 1 | 0 | 0 | X | X | X | |
| | 37 | 6E | 0 | 1 | 1 | 0 | 1 | 1 | 1 | X | L | L | L | |
| | 38 | 70 | 0 | 1 | 1 | 1 | 0 | 0 | 0 | X | L | L | NC | |
| | 39 | 72 | 0 | 1 | 1 | 1 | 0 | 0 | 1 | X | L | L | H | |
| | 3A | 74 | 0 | 1 | 1 | 1 | 0 | 1 | 0 | X | L | NC | L | |
| | 3B | 76 | 0 | 1 | 1 | 1 | 0 | 1 | 1 | X | L | NC | NC | |
| | 3C | 78 | 0 | 1 | 1 | 1 | 1 | 0 | 0 | X | L | NC | H | |
| | 3D | 7A | 0 | 1 | 1 | 1 | 1 | 0 | 1 | X | L | H | L | |
| | 3E | 7C | 0 | 1 | 1 | 1 | 1 | 1 | 0 | X | L | H | NC | |
| | 3F | 7E | 0 | 1 | 1 | 1 | 1 | 1 | 1 | X | L | H | H | |
| | 40 | 80 | 1 | 0 | 0 | 0 | 0 | 0 | 0 | X | NC | L | L | |
| | 41 | 82 | 1 | 0 | 0 | 0 | 0 | 0 | 1 | X | NC | L | NC | |
| | 42 | 84 | 1 | 0 | 0 | 0 | 0 | 1 | 0 | X | NC | L | H | |
| | 43 | 86 | 1 | 0 | 0 | 0 | 0 | 1 | 1 | X | NC | NC | L | |
| | 44 | 88 | 1 | 0 | 0 | 0 | 1 | 0 | 0 | X | NC | NC | NC | |
| | 45 | 8A | 1 | 0 | 0 | 0 | 1 | 0 | 1 | X | NC | NC | H | |
| | 46 | 8C | 1 | 0 | 0 | 0 | 1 | 1 | 0 | X | NC | H | L | |
| | 47 | 8E | 1 | 0 | 0 | 0 | 1 | 1 | 1 | X | NC | H | NC | |
| | 48 | 90 | 1 | 0 | 0 | 1 | 0 | 0 | 0 | X | NC | H | H | |
| | 49 | 92 | 1 | 0 | 0 | 1 | 0 | 0 | 1 | X | H | L | L | |
| | 4A | 94 | 1 | 0 | 0 | 1 | 0 | 1 | 0 | X | H | L | NC | |
| | 4B | 96 | 1 | 0 | 0 | 1 | 0 | 1 | 1 | X | H | L | H | |
| | 4C | 98 | 1 | 0 | 0 | 1 | 1 | 0 | 0 | X | H | NC | L | |
| | 4D | 9A | 1 | 0 | 0 | 1 | 1 | 0 | 1 | X | H | NC | NC | |
| | 4E | 9C | 1 | 0 | 0 | 1 | 1 | 1 | 0 | X | H | NC | H | |
| | 4F | 9E | 1 | 0 | 0 | 1 | 1 | 1 | 1 | X | H | H | L | |
| | 50 | A0 | 1 | 0 | 1 | 0 | 0 | 0 | 0 | X | H | H | NC | |
| | 51 | A2 | 1 | 0 | 1 | 0 | 0 | 0 | 1 | X | H | H | H | |

H = Tie to VDD, L = Tie to GND, NC = No Connect = Open, X = Don't Care

OPERATION

I²C Interface

- S START CONDITION
- Sr REPEATED START CONDITION
- Rd READ (BIT VALUE OF 1)
- Wr WRITE (BIT VALUE OF 0)
- x SHOWN UNDER A FIELD INDICATES THAT THAT FIELD IS REQUIRED TO HAVE THE VALUE OF x
- A ACKNOWLEDGE
- \bar{A} NOT ACKNOWLEDGE
- P STOP CONDITION
- MASTER TO SLAVE
- SLAVE TO MASTER

2937 F01

Figure 1. Serial Bus Protocol Diagram Element Key

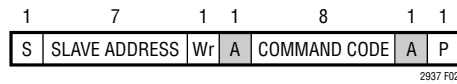

Figure 2. Send Byte Protocol

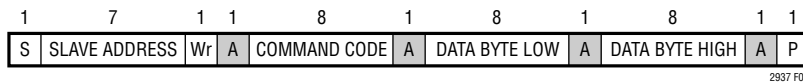

Figure 3. Write Word Protocol

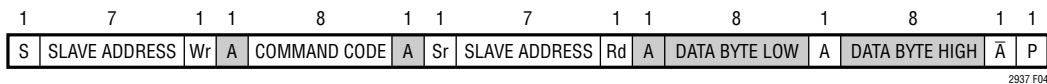

Figure 4. Read Word Protocol

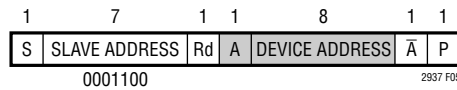

Figure 5. Alert Response Protocol

CONDENSED COMMAND SUMMARY

ON/OFF Commands

| COMMAND NAME | CMD CODE | DESCRIPTION | TYPE (Note 11) | WORD LENGTH (BITS) | EEPROM CAPACITY (BITS) | REF PAGE |
|----------------|----------|--|-------------------|--------------------------|------------------------------|-------------|
| ON_OFF_CONTROL | 0x02 | ON input and/or I ² C directed sequence up/down control settings. | R/W | 16 | 16 | 19 |

Sequencing-Up Configuration Commands

| | | | | | | |
|---------------------------|-------------|---|-----|----|----|----|
| SEQ_UP_POSITION_ <i>n</i> | 0x16 – 0x1B | Sequence-up position for EN1 through EN6. Asynchronous enable controls. | R/W | 16 | 16 | 24 |
| TON_TIMERS_ <i>n</i> | 0x0A – 0x0F | Encode EN <i>n</i> delay time and maximum rise time for V <i>n</i> . | R/W | 16 | 16 | 22 |

Voltage Supervisor Commands

| | | | | | | |
|-----------------------|-------------|--|-----|----|----|----|
| V_RANGE | 0x03 | Encode V <i>n</i> comparator ranges and Adjustable Range polarity. | R/W | 16 | 16 | 20 |
| V_THRESHOLD_ <i>n</i> | 0x04 – 0x09 | Encode high and low thresholds for V <i>n</i> . | R/W | 16 | 16 | 21 |
| RSTB_CONFIG | 0x22 | Select comparator outputs for combination into RSTB response. Select RSTB assertion delay. | R/W | 16 | 16 | 26 |

Sequencing-Down Configuration Commands

| | | | | | | |
|-----------------------------|-------------|--|-----|----|----|----|
| SEQ_DOWN_POSITION_ <i>n</i> | 0x1C – 0x21 | Sequence-down position for EN1 through EN6. Active discharge select for V1 through V6. | R/W | 16 | 16 | 25 |
| TOFF_TIMERS_ <i>n</i> | 0x10 – 0x15 | Encode EN <i>n</i> delay time and maximum fall time for V <i>n</i> . | R/W | 16 | 16 | 23 |

Fault, Status and Debugging Commands

| | | | | | | |
|------------------------|------|--|-----|----|----|----|
| FAULT_RESPONSE | 0x23 | Configure fault response actions. | R/W | 16 | 16 | 27 |
| STATUS_INFORMATION | 0x29 | Summary of current device faults and status. | R | 16 | 0 | 31 |
| MONITOR_STATUS_HISTORY | 0x26 | History of voltage monitor violations, SUPERVISOR faults and SEQUENCE faults. | R | 16 | 0 | 29 |
| MONITOR_BACKUP | 0x2F | An EEPROM copy of the MONITOR_STATUS_HISTORY word after the first SUPERVISOR or SEQUENCE fault. | R | 16 | 16 | 33 |
| MONITOR_STATUS | 0x30 | Live voltage monitor and RSTB status. | R | 16 | 0 | 34 |
| SEQ_POSITION_COUNT | 0x2B | Sequence position counter. | R | 16 | 0 | 32 |
| BREAK_POINT | 0x2A | Enable and configure sequencing break points. | R/W | 16 | 0 | 32 |
| CLEAR | 0x2E | Clear all status, fault and volatile history information. | S | 0 | 0 | 30 |
| CLEAR_ALERTB | 0x28 | Clear the ALERTB output by performing a read from this command address. The returned word contains no information. | R | 16 | 0 | 30 |

Security and Device Information Commands

| | | | | | | |
|------------------|------|--|-----|----|----|----|
| WRITE_PROTECTION | 0x00 | Contains lock key code and software lock bit to prevent accidental overwrites of volatile and nonvolatile memory. Status of WP input. | R/W | 16 | 16 | 18 |
| STORE | 0x2C | Store device configuration to EEPROM. | S | 0 | 0 | 30 |
| RESTORE | 0x2D | Restore device configuration from EEPROM. | S | 0 | 0 | 30 |
| SPECIAL_LOT | 0x01 | Contains customer specific codes that identify the factory programmed configuration stored in EEPROM. Use as a scratchpad if customer codes are not applied. | R/W | 16 | 16 | 18 |
| DEVICE_ID | 0x31 | Read only. Contains 0x2937. | R | 16 | 0 | 34 |

Note 11: R = read, W = write, S = send byte.

COMMAND DESCRIPTIONS

WRITE_PROTECTION (Command Byte 0x00)

Prevent write operations into EEPROM or volatile memory with the software lock bit $b[0] = 1$ and/or hardware lock bit $b[1] = 1$. Deactivate the software lock bit by matching the device key string in $b[15:2]$ while $b[1:0] = 00b$. Retrieve the state of the external hardware lock input (WP) in $b[1]$. Improve write security by having at least one bit in the device key set to logic 1. Change the device key if desired, when the device is unlocked.

The contents of any supported command may be read regardless of the lock bit settings. Commands are acknowledged under write protection. However, the device configuration will not change.

WRITE_PROTECTION Data Contents

| BIT(S) | SYMBOL | OPERATION |
|---------------|---------------|---|
| b[15:2] | device_key | Must match against programmed string in order to deactivate software write lock (default = 0x0EAA). |
| b[1] | hw_lock_bit | WP input status. 0: Unlocked. 1: Locked. |
| b[0] | sw_lock_bit | Software lock bit. 0: Unlocked. 1: Locked (default). |

SPECIAL_LOT (Command Byte 0x01)

Read the SPECIAL_LOT register to retrieve a customer specific code that identifies the factory programmed configuration stored in EEPROM. Use as a scratchpad if customer codes are not applied. Contact LTC Marketing to request a custom factory programmed configuration and special lot number. The default value is 0x0000.

COMMAND DESCRIPTIONS

ON_OFF_CONTROL (Command Byte 0x02)

Configure the combination of ON input and/or I²C inputs needed to control sequencing. Activate margin mode operation using b[6] or the external MARGB input. Specify time or event based sequence-down qualification. Prevent sequence-up initiation if supplies selected for sequencing are not discharged.

ON_OFF_CONTROL Data Contents

| BIT(S) | SYMBOL | OPERATION |
|---------|-----------------|---|
| b[15:8] | reserved | Ignore. |
| b[7] | on_state | Internal ON status. Representation of the ON input logically modified by the b[5:1] directives below and/or freeze mode bit b[8] from FAULT_RESPONSE (read only). 0: Internal ON is low. 1: Internal ON is high. |
| b[6] | i2c_margin | RSTB disable used during supply margining. 0: RSTB operates normally (default). 1: RSTB is allowed to pull high. |
| b[5] | discharge_start | Sequenced supply discharge threshold qualification. 0: Discharged supplies not required to start sequence-up (default). 1: Discharged supplies required to start sequence-up. |
| b[4] | i2c_on_off | Serial bus directed sequence on/off control. 0: Sequence down (default). 1: Sequence up. |
| b[3] | i2c_on_off_mask | Serial bus on/off control mask. 0: Ignore b[4]. If b[3] and b[2] are low, device is in sequence down state (default). 1: Listen to b[4]. If b[2] is high, the ON input is also required to initiate sequencing. |
| b[2] | on_input_mask | ON input mask. 0: Ignore the ON input. Sequencing control directed by b[4] if not masked (default). 1: Listen to ON input. |
| b[1] | on_polarity | Invert ON input logical state. Changing polarity should be performed with b[2] low because the response is immediate and could initiate a sequencing event. 0: Sequence up with ON input at logic high (default). 1: Sequence up with ON input at logic low. |
| b[0] | seq_down_qual | Select time or event based sequence down. 0: Event based. Sequence position clock (SPCLK) advances when supplies drop below their discharge threshold (default). 1: Time based. Sequence position clock (SPCLK) advances when respective toff_max time has elapsed, including any preceding toff_delay time (if timer set to infinity, operation defaults to voltage decay mode). |

COMMAND DESCRIPTIONS

V_RANGE

(Command Byte 0x03)

Select the operating threshold range for each of the six voltage monitor inputs. The range selection applies to the OV and UV comparators connected to each input. The High Range covers thresholds between 1V and 6V in 20mV steps. The Low Range covers thresholds between 0.5V and 3V in 10mV steps. The Adjustable Range covers 0.2V to 1.2V in 4mV steps. Select the negative polarity option in the Adjustable Range when sensing negative voltages. Discharge comparator threshold and polarity adjusts automatically in response to the configured range selection.

V_RANGE Data Contents

| BIT(S) | SYMBOL | OPERATION |
|----------|----------|---|
| b[15:12] | reserved | Ignore. |
| b[11:10] | v6_range | Select V6 range. 00b: High Range (default). 01b: Low Range. 10b: Adjustable Range (positive polarity). 11b: Adjustable Range (negative polarity). |
| b[9:8] | v5_range | Select V5 range. 00b: High Range (default). 01b: Low Range. 10b: Adjustable Range (positive polarity). 11b: Adjustable Range (negative polarity). |
| b[7:6] | v4_range | Select V4 range. 00b: High Range. 01b: Low Range (default). 10b: Adjustable Range (positive polarity). 11b: Adjustable Range (negative polarity). |
| b[5:4] | v3_range | Select V3 range. 00b: High Range. 01b: Low Range (default). 10b: Adjustable Range (positive polarity). 11b: Adjustable Range (negative polarity). |
| b[3:2] | v2_range | Select V2 range. 00b: High Range. 01b: Low Range (default). 10b: Adjustable Range (positive polarity). 11b: Adjustable Range (negative polarity). |
| b[1:0] | v1_range | Select V1 range. 00b: High Range. 01b: Low Range (default). 10b: Adjustable Range (positive polarity). 11b: Adjustable Range (negative polarity). |

COMMAND DESCRIPTIONS (Note 3)

V_THRESHOLD_n

| <i>n</i> | 1 | 2 | 3 | 4 | 5 | 6 |
|--------------|------|------|------|------|------|------|
| Command Byte | 0x04 | 0x05 | 0x06 | 0x07 | 0x08 | 0x09 |

Program the OV and UV thresholds for each of the six voltage monitor inputs.

V_THRESHOLD_n Data Contents

| BIT(S) | SYMBOL | OPERATION |
|---------|-----------------------|--|
| b[15:8] | <i>ov_threshold_n</i> | Encode one of 250 thresholds (0x05 through 0xFF). See below for voltage threshold encoding (TE) procedure. |
| b[7:0] | <i>uv_threshold_n</i> | Encode one of 250 thresholds (0x05 through 0xFF). See below for voltage threshold encoding (TE) procedure. |

Voltage Threshold Encoding

Depending on the selected voltage range, threshold encoding (TE) is determined as follows:

For the high input range of 1V to 6V, the equation is:

$$TE = \text{ROUND}[50 \cdot (V_{\text{MON}} - 0.9)]$$

For the low input range of 0.5V to 3V, the equation is:

$$TE = \text{ROUND}[100 \cdot (V_{\text{MON}} - 0.45)]$$

For the high impedance adjustable input range of 0.2V to 1.2V, the equation is:

$$TE = \text{ROUND}[250 \cdot (V_{\text{MON}} - 0.18)]$$

As an example, consider the channel 1 Low Range defaults from the table below (*ov_threshold_1* = 1.32V, *uv_threshold_1* = 1.08V). The threshold encodings (TE) are therefore:

$$TE_{\text{OV}} = \text{ROUND}[100 \cdot (1.32 - 0.45)] = \text{ROUND}[100 \cdot (0.87)] = 87 \text{ (0x57)}$$

$$TE_{\text{UV}} = \text{ROUND}[100 \cdot (1.08 - 0.45)] = \text{ROUND}[100 \cdot (0.63)] = 63 \text{ (0x3F)}$$

The 16-bit word contained in the *V_THRESHOLD_1* register (0x573F) is formed from the simple concatenation of the OV and UV hexadecimal values.

Factory Defaults

| <i>n</i> | RANGE | <i>V</i> _{MON(OV)} | <i>V</i> _{MON(UV)} | <i>TE</i> _{OV} | <i>TE</i> _{UV} |
|----------|-------|-----------------------------|-----------------------------|-------------------------|-------------------------|
| 1 | Low | 1.32 V | 1.08 V | 0x57 | 0x3F |
| 2 | Low | 1.65 V | 1.35 V | 0x78 | 0x5A |
| 3 | Low | 1.98 V | 1.62 V | 0x99 | 0x75 |
| 4 | Low | 2.75 V | 2.25 V | 0xE6 | 0xB4 |
| 5 | High | 3.63 V | 2.97 V | 0x89 | 0x68 |
| 6 | High | 5.5 V | 4.5V | 0xE6 | 0xB4 |

COMMAND DESCRIPTIONS (Note 3)**TON_TIMERS_n**

| <i>n</i> | 1 | 2 | 3 | 4 | 5 | 6 |
|--------------|------|------|------|------|------|------|
| Command Byte | 0x0A | 0x0B | 0x0C | 0x0D | 0x0E | 0x0F |

The TON_TIMER registers encode the enable delay time and the maximum allowable rise time per channel in one 16-bit word. The lowest thirteen bits (*ton_delay*) determine the amount time delay between the beginning of the programmed sequence position (determined by the SEQ_UP_POSITION_n command) and the release of the respective EN_n output (in 80μs increments).

The upper three bits (*ton_max*) determine the amount of time that is allowed to elapse between the release of EN_n and the voltage at the respective V_n input reaching its UV threshold. Failing this test can cause a sequence-up fault depending on the FAULT_RESPONSE settings. A setting of ∞ defeats time checking during the sequence-up phase for the respective channel (sequencing will pause indefinitely until the UV threshold is crossed).

TON_TIMERS_n Data Contents

| BIT(S) | SYMBOL | OPERATION |
|--------------|------------------------|--|
| b[15:13] | ton_max _n | Maximum rise time selection. Defined as the maximum time allowed between EN _n release and successful crossing of UV threshold at the V _n input. |
| | | b[15:13] ton_max |
| | | 000b ∞ (default) |
| | | 001b 160μs |
| | | 010b 640μs |
| | | 011b 2.6ms |
| | | 100b 10.2ms |
| | | 101b 41ms |
| | | 110b 164ms |
| 111b 655ms | | |
| b[12:0] | ton_delay _n | Time delay from start of selected sequence position to enable (EN _n) release. ton_delay = 80 • N μs, where N is a 13-bit unsigned integer in b[12:0]. Delay range is from 0ms to 655ms. The default setting for b[12:0] = 0. |

COMMAND DESCRIPTIONS (Note 3)

TOFF_TIMERS_n

| <i>n</i> | 1 | 2 | 3 | 4 | 5 | 6 |
|--------------|------|------|------|------|------|------|
| Command Byte | 0x10 | 0x11 | 0x12 | 0x13 | 0x14 | 0x15 |

The TOFF_TIMER registers encode the disable delay time and the maximum allowable fall time per channel in one 16-bit word. The lowest thirteen bits (*toff_delay*) determine the amount time delay between the beginning of the programmed sequence position (determined by the SEQ_DOWN_POSITION_n command) and the pull-down of the respective ENn output (in 80µs increments).

The upper three bits (*toff_max*) determine the amount of time that is allowed to elapse between the pull-down of ENn and the voltage at the respective Vn input falling below its discharge threshold. Failing this test can cause a sequence-down fault depending on the FAULT_RESPONSE settings. A setting of ∞ defeats time checking during the sequence-down phase for the respective channel (sequencing will pause indefinitely until the monitored voltage decays below its discharge threshold).

Sequence-down progress may also be gated by time instead of voltage decay. Choose the time based mode of operation with b[0] = 1 in the ON_OFF_CONTROL register. Use the *toff_max* settings below to set the time from ENn pulling low to the start of next sequence position. If multiple channels occupy the same sequence position, the longest combined time (*toff_delay_n + toff_max_n*) determines the sequence position hold time. In time delay mode, a *toff_max* setting of ∞ defaults operation to voltage decay mode.

TOFF_TIMERS_n Data Contents

| BIT(S) | SYMBOL | OPERATION | |
|----------|--------------|--|-------------|
| b[15:13] | toff_max_n | Maximum fall time selection. Defined as the maximum time allowed between ENn pull-down and successful crossing of the discharge threshold at the Vn input. | |
| | | b[15:13] | toff_max |
| | | 000b | ∞ (default) |
| | | 001b | 2.6ms |
| | | 010b | 10.2ms |
| | | 011b | 41ms |
| | | 100b | 164ms |
| | | 101b | 655ms |
| | | 110b | 2.6s |
| | | 111b | 10.5s |
| b[12:0] | toff_delay_n | Time delay from start of selected sequence position to enable (ENn) pull-down. toff_delay = 80 • N µs, where N is the 13-bit unsigned integer in b[12:0]. The default setting for b[12:0] = 0. | |

COMMAND DESCRIPTIONS (Note 3)**SEQ_UP_POSITION_n**

| <i>n</i> | 1 | 2 | 3 | 4 | 5 | 6 |
|--------------|------|------|------|------|------|------|
| Command Byte | 0x16 | 0x17 | 0x18 | 0x19 | 0x1A | 0x1B |

Program the sequence position in which the respective enable output is allowed to pull high. Select from 1023 positions (1 through 1023) controlled by the sequence position clock (SPCLK) connected to all LTC2937s. Sequence-up positions may be different from the respective sequence-down positions. Any and all enable outputs may operate in any sequence position. If b[9:0] are set equal to 0, the respective channel is not participating and is ignored during sequencing up and down. A setting of zero enables the asynchronous on/off bit providing immediate enable output response. If the asynchronous on/off bit is in use, the respective channel does not participate in sequencing events but the respective UV/OV monitor conditions may be included in the RSTB response. Unused sequence positions add an 80µs space ($t_{HI} + t_{LO}$) between configured sequence positions. SPCLK self terminates after the last used sequence position.

SEQ_UP_POSITION_n Data Contents

| BIT(S) | SYMBOL | OPERATION |
|----------|-------------------|--|
| b[15:11] | reserved | Ignore. |
| b[10] | async_on_off_n | Asynchronous enable control. Release or pull-down the respective enable output immediately provided that b[9:0] = 0. 0: Pull down ENn immediately (default). 1: Release ENn immediately. |
| b[9:0] | seq_up_position_n | Specify a sequence-up position from 1 to 1023. If b[9:0] = 0, the channel does not participate in sequencing operations. Default b[9:0] = 0x001 (position 1). |

COMMAND DESCRIPTIONS (Note 3)

SEQ_DOWN_POSITION_n

| <i>n</i> | 1 | 2 | 3 | 4 | 5 | 6 |
|--------------|------|------|------|------|------|------|
| Command Byte | 0x1C | 0x1D | 0x1E | 0x1F | 0x20 | 0x21 |

Program the sequence position in which the respective enable output is pulled down. Select from 1023 positions (1 through 1023) controlled by the sequence position clock (SPCLK) connected to all LTC2937s. Sequence-down positions may be different from the respective sequence-up positions. Any and all enable outputs may operate in any sequence position. If b[9:0] are set equal to 0, the respective channel is not participating and is ignored during sequencing down and up. Selectively configure V_n inputs to receive current source pull-down when respective enable outputs are low. The active pull-down can be used to reduce power supply discharge time. Unused sequence positions add an 80 μ s space ($t_{HI} + t_{LO}$) between configured sequence positions. SPCLK self terminates after the last used sequence position.

SEQ_DOWN_POSITION_n Data Contents

| BIT(S) | SYMBOL | OPERATION |
|----------|---------------------|--|
| b[15:11] | reserved | Ignore. |
| b[10] | active_pull_down_n | Apply pull-down current source to respective V_n inputs to reduce power supply discharge time. If enabled, the source is active when the respective EN_n output is low. 0: Active pull-down disabled (default). 1: Active pull-down enabled. |
| b[9:0] | seq_down_position_n | Specify a sequence-down position from 1 to 1023. If b[9:0] = 0, the channel does not participate in sequencing operations. Default b[9:0] = 0x001 (position 1). |

COMMAND DESCRIPTIONS

RSTB_CONFIG

(Command Byte 0x22)

Select the RSTB assertion delay. Select UV and OV comparator outputs for combination into the RSTB output. If no comparators are included, the RSTB output assertion delay is gated only by the device's internal undervoltage lockout condition. After sequencing up has commenced, SUPERVISOR faults may optionally cause device faults (set with b[12]). Consult the Applications Information for a complete discussion regarding the distinctions between SUPERVISOR faults and the state of the RSTB output.

RSTB_CONFIG Data Contents

| BIT(S) | SYMBOL | OPERATION | |
|----------|-----------------|--|-----------------|
| b[15:13] | rstb_delay | Encode RSTB output assertion delay. | |
| | | b[15:13] | rstb_delay |
| | | 000b | 0.05ms |
| | | 001b | 1.6ms |
| | | 010b | 6.4ms |
| | | 011b | 26ms |
| | | 100b | 51ms |
| | | 101b | 200ms (default) |
| | | 110b | 410ms |
| | | 111b | 1640ms |
| b[12] | sv_fault_enable | Allow a SUPERVISOR fault to pull FAULTB. 0: SUPERVISOR fault does not pull FAULTB. 1: SUPERVISOR fault pulls FAULTB (default). | |
| b[11] | v6_ov_enable | Add V6 OV status into RSTB output. 0: Not enabled (default). 1: Enabled. | |
| b[10] | v5_ov_enable | Add V5 OV status into RSTB output. 0: Not enabled (default). 1: Enabled. | |
| b[9] | v4_ov_enable | Add V4 OV status into RSTB output. 0: Not enabled (default). 1: Enabled. | |
| b[8] | v3_ov_enable | Add V3 OV status into RSTB output. 0: Not enabled (default). 1: Enabled. | |
| b[7] | v2_ov_enable | Add V2 OV status into RSTB output. 0: Not enabled (default). 1: Enabled. | |
| b[6] | v1_ov_enable | Add V1 OV status into RSTB output. 0: Not enabled (default). 1: Enabled. | |
| b[5] | v6_uv_enable | Add V6 UV status into RSTB output. 0: Not enabled. 1: Enabled (default). | |
| b[4] | v5_uv_enable | Add V5 UV status into RSTB output. 0: Not enabled. 1: Enabled (default). | |
| b[3] | v4_uv_enable | Add V4 UV status into RSTB output. 0: Not enabled. 1: Enabled (default). | |
| b[2] | v3_uv_enable | Add V3 UV status into RSTB output. 0: Not enabled. 1: Enabled (default). | |
| b[1] | v2_uv_enable | Add V2 UV status into RSTB output. 0: Not enabled. 1: Enabled (default). | |
| b[0] | v1_uv_enable | Add V1 UV status into RSTB output. 0: Not enabled. 1: Enabled (default). | |

COMMAND DESCRIPTIONS

FAULT_RESPONSE **(Command Byte 0x23)**

The FAULT_RESPONSE command defines the LTC2937 response to system faults (SEQUENCE, SUPERVISOR, CONTROL or OTHER). An OTHER fault may occur from external pull-down on the FAULTB output, or a loss of SHARE_CLK operation (mask EXTERNAL faults with b[9]). FAULTB pulls low after any of these faults occur.

A freeze mode is available, stopping the sequencing process (if any) and leaving any enabled supplies turned on. This mode should be used with care and is discussed in the applications information.

Automatic re-sequencing is permitted on a time basis or voltage basis, depending on the fault_response_action bits b[4:3]. Using voltage basis, automatic re-sequencing is allowed when monitored supplies have decayed below their respective discharge thresholds. Using time basis allows re-sequencing after 1 of 8 selectable time delays with b[7:5] (without regard to the level of the monitored input voltages). Retries using the combined basis of discharge condition and time delay is also available. Another option is to continue without shutdown, as if nothing is wrong (FAULTB still pulls low).

Set the number of retries allowed with b[2:0]. Retrieve the number of retries attempted (with b[13:11]) after the initial sequencing operation.

Consult the Applications Information for a complete discussion regarding the definition of SEQUENCE, SUPERVISOR, CONTROL and OTHER faults, including more information concerning fault response operations.

COMMAND DESCRIPTIONS

The FAULT_RESPONSE data content is shown below.

FAULT_RESPONSE Data Contents

| BIT(S) | SYMBOL | OPERATION | |
|----------|-----------------------|--|----------------------------|
| b[15:14] | reserved | Ignore. | |
| b[13:11] | retry_count | Read the number of retries attempted. The counter is cleared with any new sequencing-up operation initiated by the ON input or I ² C command. The counter may also be cleared using the CLEAR command (read only). | |
| b[10] | faultb_state | Read the state of FAULTB (read only). | |
| b[9] | faultb_mask | Select device response to external pull-down on FAULTB. 0: Ignore external FAULTB pull-down (default). 1: Respond to external FAULTB pull-down. Sequenced EN/n outputs pull down immediately if not frozen with b[8] below. | |
| b[8] | freeze | Select system freeze response due to a fault. 0: Do not freeze on fault (default). 1: Freeze device state on fault. | |
| b[7:5] | retry_delay | Specify the delay between automatic re-sequencing retries. | |
| | | b[7:5] | retry_delay |
| | | 000b | 0.05 ms (default) |
| | | 001b | 200ms |
| | | 010b | 410ms |
| | | 011b | 820ms |
| | | 100b | 1.64s |
| | | 101b | 3.28s |
| | | 110b | 6.55s |
| b[4:3] | fault_response_action | Select shutdown and restart action after a fault. Consult applications information for more details. | |
| | | b[4:3] | fault_response_action |
| | | 00b | Continue operation |
| | | 01b | Discharged retry (default) |
| | | 10b | Delayed retry |
| b[2:0] | retry_number | Specify the automatic retry count. Consult applications information for more details. | |
| | | b[2:0] | retry_number |
| | | 000b | 0 (default) |
| | | 001b | 1 |
| | | 010b | 2 |
| | | 011b | 3 |
| | | 100b | 4 |
| | | 101b | 5 |
| 110b | 6 | | |
| 111b | Unlimited retries | | |

COMMAND DESCRIPTIONS

MONITOR_STATUS_HISTORY

(Command Byte 0x26)

The MONITOR_STATUS_HISTORY command returns two bytes of information with a summary of present and past SUPERVISOR and SEQUENCE faults. Consult the Applications Information section for a complete definition of SUPERVISOR and SEQUENCE faults. Detected SEQUENCE faults are reported with the lowest numbered channel having report priority. SUPERVISOR faults can only occur through comparators mapped to the reset logic. A valid sequence-up initiation automatically clears the MONITOR_STATUS_HISTORY. Use the CLEAR command (0x2E) to reset the history contents to 0x0000.

MONITOR_STATUS_HISTORY Data Contents (read only)

| BIT(S) | SYMBOL | OPERATION |
|-----------------|-----------------|--|
| b[15:13] | sf_chan_hist | SEQUENCE fault channel. Lowest numbered channel has report priority. |
| | | b[15:13] sf_channel |
| | | 000b No fault |
| | | 001b V1 |
| | | 010b V2 |
| | | 011b V3 |
| | | 100b V4 |
| | | 101b V5 |
| | | 110b V6 |
| 111b reserved | | |
| b[12] | sv_fault_status | SUPERVISOR fault status. 0: SUPERVISOR fault has not occurred. 1: SUPERVISOR fault has occurred. |
| b[11] | v6_ov_sv_fault | V6 OV SUPERVISOR fault history. 0: No fault. 1: Fault occurred. |
| b[10] | v6_uv_sv_fault | V6 UV SUPERVISOR fault history. 0: No fault. 1: Fault occurred. |
| b[9] | v5_ov_sv_fault | V5 OV SUPERVISOR fault history. 0: No fault. 1: Fault occurred. |
| b[8] | v5_uv_sv_fault | V5 UV SUPERVISOR fault history. 0: No fault. 1: Fault occurred. |
| b[7] | v4_ov_sv_fault | V4 OV SUPERVISOR fault history. 0: No fault. 1: Fault occurred. |
| b[6] | v4_uv_sv_fault | V4 UV SUPERVISOR fault history. 0: No fault. 1: Fault occurred. |
| b[5] | v3_ov_sv_fault | V3 OV SUPERVISOR fault history. 0: No fault. 1: Fault occurred. |
| b[4] | v3_uv_sv_fault | V3 UV SUPERVISOR fault history. 0: No fault. 1: Fault occurred. |
| b[3] | v2_ov_sv_fault | V2 OV SUPERVISOR fault history. 0: No fault. 1: Fault occurred. |
| b[2] | v2_uv_sv_fault | V2 UV SUPERVISOR fault history. 0: No fault. 1: Fault occurred. |
| b[1] | v1_ov_sv_fault | V1 OV SUPERVISOR fault history. 0: No fault. 1: Fault occurred. |
| b[0] | v1_uv_sv_fault | V1 UV SUPERVISOR fault history. 0: No fault. 1: Fault occurred. |

COMMAND DESCRIPTIONS

CLEAR_ALERTB

(Command Byte 0x28)

Release the ALERTB output pull-down by performing a read from the CLEAR_ALERTB register. All other status information remains unaffected. The returned data word contains no useful information and the contents should be ignored.

STORE

(Command Byte 0x2C)

Send the STORE command whenever the current operating configuration requires saving to nonvolatile memory. Future power-on events automatically load the stored operating configuration. The STORE command is ignored when the WP input is high and/or b[0] of the WRITE_PROTECTION register is equal to 1. Write permission is guarded by a 14-bit security key providing additional security to stored content. The STORE command is best used while controlled supplies are off or sequenced-down, to prevent unintended results.

RESTORE

(Command Byte 0x2D)

Send the RESTORE command whenever the current operating configuration requires an update from nonvolatile memory. A restore from EEPROM occurs automatically when emerging from power-on reset after device power is applied. The RESTORE command is best used while controlled supplies are off or sequenced-down, to prevent unintended results.

CLEAR

(Command Byte 0x2E)

Send the CLEAR command to clear active status, fault and volatile history information. The CLEAR command also resets the sequencing state machine so it is best used while controlled supplies are off or sequenced-down to prevent inadvertent system operation. Affected registers are: STATUS_INFORMATION, MONITOR_STATUS_HISTORY, MONITOR_STATUS and SEQ_POSITION_COUNT, ON_OFF_CONTROL b[7] and FAULT_RESPONSE b[13:11]. If CLEAR is immediately followed by a STORE command, the MONITOR_BACKUP register is also cleared.

COMMAND DESCRIPTIONS

STATUS_INFORMATION (Command Byte 0x29)

The STATUS_INFORMATION command returns a summary of faults and sequencing status flags which have occurred. The register is self-clearing at the beginning of a new sequence-up operation or after a power-on reset. One exception is mb_state (b[12]) which indicates whether or not the MONITOR_BACKUP register has been written. After a power-on reset, b[12] is updated automatically. Perform a CLEAR command followed by a STORE command to reset b[12] to logic low.

STATUS_INFORMATION Data Contents (read only)

| BIT(S) | SYMBOL | OPERATION |
|------------------------|-------------------|--|
| b[15:13] | sf_channel | SEQUENCE fault channel. Lowest numbered channel has report priority. |
| | | b[15:13] sf_channel |
| | | 000b No fault |
| | | 001b V1 |
| | | 010b V2 |
| | | 011b V3 |
| | | 100b V4 |
| | | 101b V5 |
| | | 110b V6 |
| 111b reserved | | |
| b[12] | mb_state | MONITOR_BACKUP register status. 0: MONITOR_BACKUP empty. 1: MONITOR_BACKUP written. |
| b[11:10] | local_seq_status | Addressed device sequencing status. 00b: Sequence-down complete (power-on default state). 01b: Sequence-up in progress. 11b: Sequence-up complete. 10b: Sequence-down in progress. |
| b[9:8] | group_seq_status | Device group sequencing status (for multiple devices connected to SPCLK). 00b: Sequence-down complete (power-on default state). 01b: Sequence-up in progress. 11b: Sequence-up complete. 10b: Sequence-down in progress. |
| b[7] | seq_up_fault | Maximum rise time fault. 0: No fault. 1: Fault occurred. |
| b[6] | seq_down_fault | Maximum fall time fault. 0: No fault. 1: Fault occurred. |
| b[5] | ov_fault | SUPERVISOR fault caused by mapped OV condition. 0: No fault. 1: Fault occurred. |
| b[4] | uv_fault | SUPERVISOR fault caused by mapped UV condition. 0: No fault. 1: Fault occurred. |
| b[3] | sv_fault | SUPERVISOR fault status. 0: No fault. 1: Fault occurred. |
| b[2] | discharge | Discharge status. 0: One or more sequenced voltages are above discharge thresholds. 1: All sequenced voltages are below discharge thresholds. |
| b[1] | seq_control_fault | Sequence CONTROL fault status. 0: No fault. 1: Fault. |
| b[0] | other_fault | EXTERNAL fault or SHARE_CLK fault status. 0: No fault. 1: Fault occurred. |

COMMAND DESCRIPTIONS

BREAK_POINT

(Command Byte 0x2A)

Pause sequencing at any valid sequence position (occurs during SPCLK low period). Set sequence position break points in the sequence-up or sequence-down phase of operation. Enable break point usage with bp_enable b[10]. With break point usage enabled, a valid control input (ON transition or I²C command) will sequence the device until sp_count in the SEQ_POSITION_COUNT register is equal to bp_value in the BREAK_POINT register. Perform register inspections and system measurements at each paused sequence position. Increment the BREAK_POINT register repeatedly for controlled single stepping through all sequence positions. SPCLK holds low until bp_value is changed to be not equal to sp_count or bp_enable is set low. The sequencing enable delay timers and maximum rise/fall timers function normally at each sequence position.

BREAK_POINT Data Contents

| BIT(S) | SYMBOL | OPERATION |
|----------|-----------|---|
| b[15:11] | reserved | Ignore. |
| b[10] | bp_enable | Break point mode. 0: Break point mode not enabled (default). 1: Break point mode enabled. |
| b[9:0] | bp_value | Break point sequence position value. Specify a sequence position break point from 0 to 1023. (Default = 0x000). |

SEQ_POSITION_COUNT

(Command Byte 0x2B)

Read the current sequence position count contained in the sp_count bit field. The sp_count bit field is zero after initial application of device power or after a CLEAR command. At the conclusion of all sequence-up or sequence-down operations, sp_count increments by one. For example, if the last configured sequence position is 10, sp_count increments to 11 when the sequencing operation completes. If the last sequence position is 1023, sp_count rolls over to zero at the end of sequencing. After a fault (whether in break point mode or normal operation), the current sequence position value is reported until the fault exit conditions are satisfied.

SEQ_POSITION_COUNT Data Contents (read only)

| BIT(S) | SYMBOL | OPERATION |
|----------|------------|---|
| b[15:11] | reserved | Ignore. |
| b[10] | sp_bp_test | Compare sp_count with bp_value. 0: sp_count is not equal to bp_value. 1: sp_count is equal to bp_value. |
| b[9:0] | sp_count | Sequence position count. |

COMMAND DESCRIPTIONS

MONITOR_BACKUP (Command Byte 0x2F)

The MONITOR_BACKUP register mirrors the contents of the MONITOR_STATUS_HISTORY upon the first detected SEQUENCE or SUPERVISOR fault. Subsequent faults are not stored so that the first fault can always be retrieved even after complete device power cycling. Retrieve the backup word by issuing a RESTORE command followed by a MONITOR_BACKUP read. Clear the backup word by performing a CLEAR command followed by a STORE command. After a device power cycle, MONITOR_BACKUP updates automatically, so a RESTORE command is not required prior to a MONITOR_BACKUP read. Backup register contents can be modified by the first SUPERVISOR or SEQUENCE fault if a power cycle or CLEAR command has been performed. Please note that when resetting the backup register using CLEAR and STORE, any modifications to the volatile memory in other registers will be written to EEPROM during the STORE procedure.

MONITOR_BACKUP Data Contents (read only)

| BIT(S) | SYMBOL | OPERATION |
|-----------------|-------------------|---|
| b[15:13] | bu_sf_chan | SEQUENCE fault channel backup. Lowest numbered channel has report priority. |
| | | b[15:13] sf_channel |
| | | 000b No fault |
| | | 001b V1 |
| | | 010b V2 |
| | | 011b V3 |
| | | 100b V4 |
| | | 101b V5 |
| | | 110b V6 |
| 111b reserved | | |
| b[12] | bu_svf_state | SUPERVISOR fault status backup. 0: SUPERVISOR fault has not occurred. 1: SUPERVISOR fault has occurred. |
| b[11] | bu_v6_ov_sv_fault | V6 OV SUPERVISOR fault backup. 0: No fault. 1: Fault occurred. |
| b[10] | bu_v6_uv_sv_fault | V6 UV SUPERVISOR fault backup. 0: No fault. 1: Fault occurred. |
| b[9] | bu_v5_ov_sv_fault | V5 OV SUPERVISOR fault backup. 0: No fault. 1: Fault occurred. |
| b[8] | bu_v5_uv_sv_fault | V5 UV SUPERVISOR fault backup. 0: No fault. 1: Fault occurred. |
| b[7] | bu_v4_ov_sv_fault | V4 OV SUPERVISOR fault backup. 0: No fault. 1: Fault occurred. |
| b[6] | bu_v4_uv_sv_fault | V4 UV SUPERVISOR fault backup. 0: No fault. 1: Fault occurred. |
| b[5] | bu_v3_ov_sv_fault | V3 OV SUPERVISOR fault backup. 0: No fault. 1: Fault occurred. |
| b[4] | bu_v3_uv_sv_fault | V3 UV SUPERVISOR fault backup. 0: No fault. 1: Fault occurred. |
| b[3] | bu_v2_ov_sv_fault | V2 OV SUPERVISOR fault backup. 0: No fault. 1: Fault occurred. |
| b[2] | bu_v2_uv_sv_fault | V2 UV SUPERVISOR fault backup. 0: No fault. 1: Fault occurred. |
| b[1] | bu_v1_ov_sv_fault | V1 OV SUPERVISOR fault backup. 0: No fault. 1: Fault occurred. |
| b[0] | bu_v1_uv_sv_fault | V1 UV SUPERVISOR fault backup. 0: No fault. 1: Fault occurred. |

COMMAND DESCRIPTIONS

MONITOR_STATUS

(Command Byte 0x30)

The MONITOR_STATUS command returns a summary of the present (live) voltage monitor conditions. UV and OV status are always active. The external status of the RSTB I/O is reported on b[12] and will indicate low if an external device is pulling down on RSTB. Comparator live status is not affected by settings in the RSTB_CONFIG register.

MONITOR_STATUS Data Contents (read only)

| BIT(S) | SYMBOL | OPERATION |
|----------|---------------|---|
| b[15:14] | reserved | Ignore. |
| b[13] | margin_status | Logical representation of the external margin input and/or I ² C margin control bit. 0: Margin function inactive. 1: Margin function active. |
| b[12] | rstb_status | Status of the RSTB I/O. 0: RSTB is high. 1: RSTB is low. |
| b[11] | v6_ov_status | V6 OV comparator live status. 0: No violation. 1: High limit violation. |
| b[10] | v6_uv_status | V6 UV comparator live status. 0: No violation. 1: Low limit violation. |
| b[9] | v5_ov_status | V5 OV comparator live status. 0: No violation. 1: High limit violation. |
| b[8] | v5_uv_status | V5 UV comparator live status. 0: No violation. 1: Low limit violation. |
| b[7] | v4_ov_status | V4 OV comparator live status. 0: No violation. 1: High limit violation. |
| b[6] | v4_uv_status | V4 UV comparator live status. 0: No violation. 1: Low limit violation. |
| b[5] | v3_ov_status | V3 OV comparator live status. 0: No violation. 1: High limit violation. |
| b[4] | v3_uv_status | V3 UV comparator live status. 0: No violation. 1: Low limit violation. |
| b[3] | v2_ov_status | V2 OV comparator live status. 0: No violation. 1: High limit violation. |
| b[2] | v2_uv_status | V2 UV comparator live status. 0: No violation. 1: Low limit violation. |
| b[1] | v1_ov_status | V1 OV comparator live status. 0: No violation. 1: High limit violation. |
| b[0] | v1_uv_status | V1 UV comparator live status. 0: No violation. 1: Low limit violation. |

DEVICE_ID

(Command Byte 0x31)

The DEVICE_ID command returns two bytes containing the part number 0x2937. This register is read only.

APPLICATIONS INFORMATION

Introduction

The LTC2937 power management IC provides time and event based sequencing, undervoltage and overvoltage supervision and fault management.

Powering the LTC2937

Two options exist for applying LTC2937 device power. If an intermediate bus voltage between 4.5V and 16.5V is available, connect it to the VPWR input. An internal linear regulator converts VPWR down to 3.3V which drives all internal circuitry. The regulated 3.3V also drives VDD and requires a 2.2 μ F (or greater) compensation capacitor. Alternatively, apply an external supply voltage between 2.9V and 5.5V directly to VDD and VPWR. When driving VDD directly, a compensation capacitor is not required, but a decoupling capacitor (0.1 μ F) is recommended.

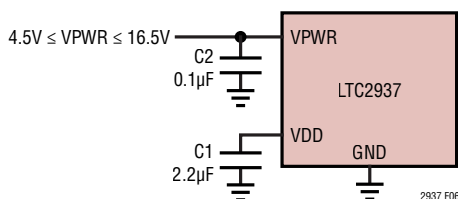

Figure 6. Powering LTC2937 Directly from an Intermediate Bus Voltage

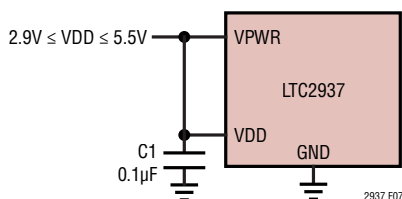

Figure 7. Powering LTC2937 Directly from Low Supply Voltage

During initial application of LTC2937 device power, device configuration transfers from EEPROM into the volatile operating memory after VDD exceeds undervoltage lockout. The restore time is 2ms maximum. Perform changes to device configuration, sequencing and/or supervisory operations after completion of the restore procedure.

Write Protection

To prevent accidental writes to memory (volatile and nonvolatile), apply the software and/or hardware lock functions. Software protection is active when the WRITE_PROTECTION register lock bit b[0] = 1. Deactivate the software lock by writing bit[0] = 0 while matching the 14 bit key string contained in b[15:2]. The hardware lock is active when the WP input is pulled to VDD. Deactivate the hardware lock by pulling the WP input to ground.

Write protection must be de-activated when it is desired to write changes to the volatile or nonvolatile memory. The usual cause of seemingly ignored write operations is due to active write protection. The LTC2937 will acknowledge I²C commands while under write protection. However, the part configuration will not change.

Updating Volatile or Nonvolatile Memory

Changes to the EEPROM require a 2-step procedure. First, write desired values to the command registers. Then, perform the STORE command. Command register configuration will be copied to the EEPROM. Maximum write time is 120ms. Perform a RESTORE command to move EEPROM data into the volatile command registers. The LTC2937 does not acknowledge commands while the EEPROM is writing.

Volatile command register contents are often changed during system testing or development. If desired, restore the command register contents to the stored configuration in EEPROM by performing the RESTORE command. To prevent unintended operation, send the RESTORE command after sequence-down and after sending a CLEAR command. A RESTORE is performed automatically at initial device power-on.

Changes to the volatile memory can be performed at any time. However, some changes should only be made when the system is in the sequenced-down or off state because writes to volatile memory have immediate influence. If the system is actively sequencing or monitoring, and certain changes occur, unintended consequences may

APPLICATIONS INFORMATION

result because of contradictions within the sequencing state machine. To prevent unintended operation, send a CLEAR command after sequence-down, prior to making changes to volatile memory. Use caution when writing the following commands during the sequencing and monitoring phases of operation:

- ON_OFF_CONTROL b[5, 1, 0]
- V_RANGE
- V_THRESHOLD_{*n*}
- TON_TIMERS_{*n*}
- TOFF_TIMERS_{*n*}
- SEQ_UP_POSITION_{*n*}
- SEQ_DOWN_POSITION_{*n*}
- RSTB_CONFIG
- FAULT_RESPONSE
- CLEAR, STORE, RESTORE

Certain registers have reserved bits in some bit locations. To avoid confusion, mask out or ignore those bits when reading back the contents of those registers. Each command description details the location of the reserved bits. When writing to commands with reserved bits, data content in those bit locations are disregarded.

Sequence Position Clock (SPCLK)

When a system requires more than six controlled power supplies, use SPCLK to maintain seamless multi-channel sequencing control across all devices. SPCLK is a single wire event control signal and other than the simple interconnection of SPCLK between devices, additional external device connections to SPCLK are not required or recommended.

Using SPCLK, up to 300 power supplies can be controlled by connecting up to 50 LTC2937s together. Arrange power supply sequence order in any one of 1023 available sequence positions. When applying device power directly to VDD, connect VDD together across all devices. When applying device power to VPWR, the regulated VDD outputs do not require parallel connection.

After initial device power is applied, SPCLK holds low in the non-sequencing phase of operation. Once sequencing is initiated, SPCLK pulls high for 60 μ s (t_{HI}) and then pulls low. The system is now in sequence position 1. If there are no supplies scheduled for sequencing in position 1, SPCLK pulls high again after 20 μ s (t_{LO}). SPCLK remains high for 60 μ s (t_{HI}) and then pulls low again. This cycle repeats (Figure 8) until a power supply scheduled for sequencing is encountered.

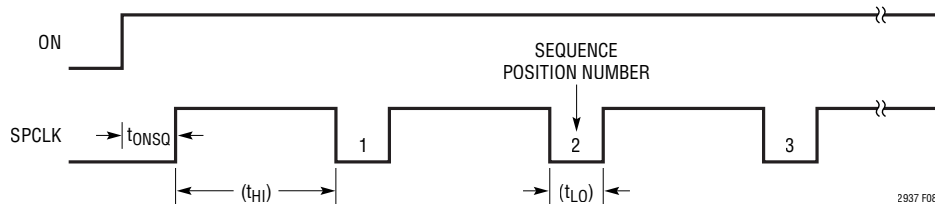

Figure 8. SPCLK Nominal Timing

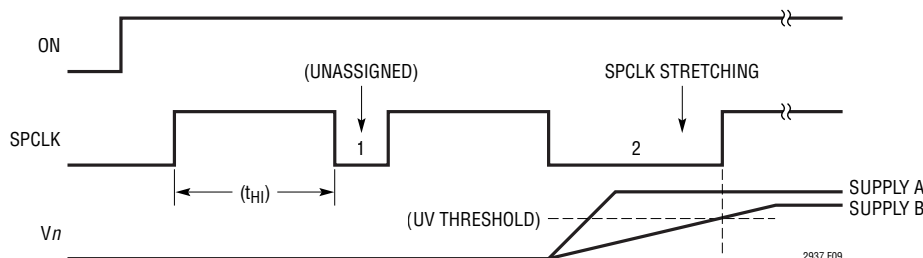

Figure 9. SPCLK Stretching

APPLICATIONS INFORMATION

During the sequence-up phase, enable outputs on any LTC2937 scheduled for a particular sequence position pull high after their respective turn-on delay. Turn-on delay is measured from the falling edge of SPCLK. The delay times are individually programmed for each enable output. SPCLK is stretched and remains low (Figure 9) until all supplies scheduled for the current sequence position have crossed their UV threshold. SPCLK then pulls high for 60 μ s (t_{HI}) and again pulls low, placing all devices into the next sequence position. The process repeats until all power supplies scheduled for sequencing have completed powering up. After the last power supply powers up, SPCLK pulls high for 320 μ s (t_{FLOAT}) and then pulls low. The sequence-up phase of operation is complete. SPCLK operates in the same manner during sequence-down operation.

Enable any number of supplies in any sequence position using any number of LTC2937s (Figure 9). When using multiple LTC2937s, freely interleave power supply sequencing between devices. For example, enable any number of supplies on a first device, then enable any number of supplies on another device, then again from the first device and so forth. Reserve certain sequence positions for possible insertion of additional power supplies. Note that in Figure 9, sequence position 1 is unassigned or reserved for future use. Leaving sequence positions unassigned can be good practice during system development as it allows for future expansion or insertion of supplies without having to reprogram all LTC2937's in the system. Simply position a new supply in an unassigned sequence position and all succeeding positions slide appropriately.

System Configuration

The procedure described herein is intended as a reference and for the purpose of understanding the registers in a software development environment. Configure LTC2937 standalone operation using the LTC USB to I²C/SMBus/PMBus controller (DC1613) and LTpowerPlay software GUI using intuitive menu driven objects.

Simplify the procedure of system configuration by configuring command register contents in a task oriented manner. For example, a typical system can be divided into four regions of operation:

1. Sequence-Up and Sequence-Down Control

(select sequence initiation method)

2. Sequence-Up Parameters

(sequence-up order, time spacing and maximum rise time)

3. Voltage Supervision

(monitored voltage range, voltage threshold and reset response)

4. Sequence-Down Parameters

(sequence-down order, time spacing and maximum fall time)

Beyond the sequence and supervisory commands are a set of commands for fault management, status information, system debug and general information. These commands are discussed further below. Note that the command summary table is also organized in a task oriented fashion.

Sequence-Up and Sequence-Down Control

Various sequence-up and sequence-down control options are specified through the ON_OFF_CONTROL command. To initiate sequencing, use the polarity selectable ON input and/or I²C on/off bit. If specifications require sequencing-up to begin with discharged supplies, set b[5]=1 to enforce qualification.

If b[5] = 1, the LTC2937 prohibits initial sequencing until supplies configured for sequencing are discharged. If a fault has occurred and automatic retries are enabled, re-sequencing conditions obey the discharge and/or time delay rules specified in the FAULT_RESPONSE register.

To start sequence-down operations, switch the ON input or I²C on/off bit to the off state. Sequence positions are advanced on the basis of sequenced supply voltage level or configured time-delay. Select this distinction with ON_OFF_CONTROL b[0].

The i2c_on_off_mask and on_input_mask bits (b[3:2]) are set low by default. This prevents any sequencing from occurring at initial application of device power. Since the ON input has an internal pull-up current source, automatic sequencing is possible (with default ON polarity) if the on_input_mask = 1 and the ON input is not held low.

APPLICATIONS INFORMATION

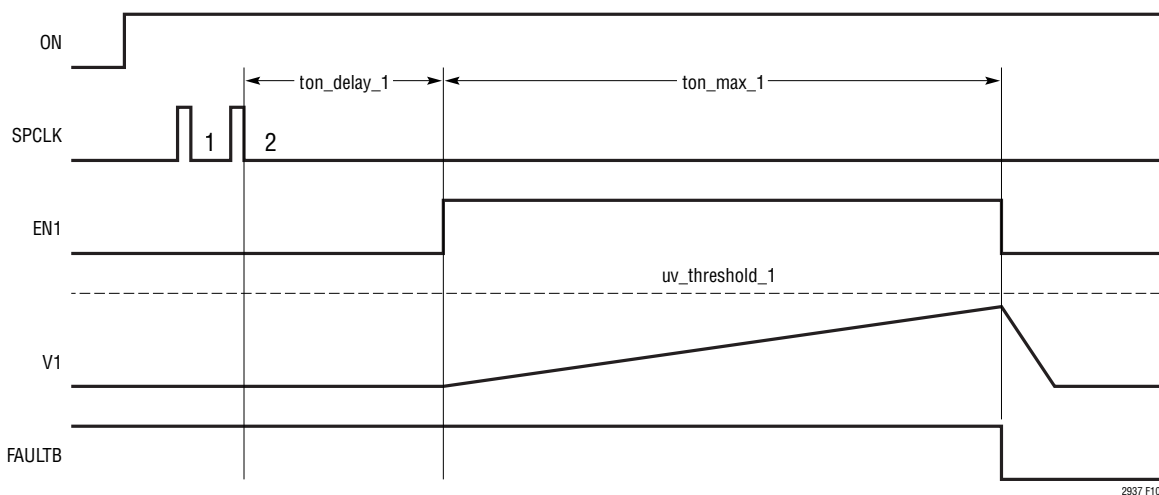

Figure 10. Sequence-Up Timing Parameters (V1 Set to Sequence Up in Sequence Position 2) Showing SEQUENCE FAULT

Sequence-Up Parameters

Sequence-up configuration consists of defining the sequence position for each sequenced supply, the time delay to enable (measured from the falling edge of SPCLK) and the maximum allowed elapsed time (from enable) for each sequenced supply to reach its UV threshold. Configure these parameters with the SEQ_UP_POSITION_*n* and TON_TIMERS_*n* commands (where *n* denotes the channel number).

Figure 10 graphically depicts parameters for a hypothetical supply operating in channel 1. Sequencing is initiated with the ON input. In this example, the supply is enabled in sequence position 2, with an enable delay (*ton_delay_1*) of 800 μ s and a maximum rise time (*ton_max_1*) of 10.24ms. Because V1 does not meet its rise time requirements (V1 is below *uv_threshold_1* when *ton_max* is reached), a sequence-up fault occurs and all enables are turned off. The corresponding command register values are:

SEQ_UP_POSITION_1 = 0x0002

TON_TIMERS_1 = 0x8064

Voltage Supervision

There are three steps to programming voltage supervision. First, configure the voltage range for each monitored input. Second, configure the UV, OV and discharge thresholds for each monitored input. Lastly, decide on which monitored inputs contribute to the RSTB response.

The LTC2937 provides 12 independently programmable high accuracy voltage monitor comparators. There are two comparators per *V_n* input, typically used for undervoltage and overvoltage detection. Each comparator provides 750 thresholds (250 thresholds in each of 3 voltage input ranges), from 0.2V to 6V. Additionally, each *V_n* input contains a discharge comparator which determines when monitored voltages have decayed to a substantially low level.

Voltage Monitor Range

The V_RANGE command contains encoding to program the voltage threshold range for each of the six monitor inputs (V1 through V6). The range selection applies to the OV and UV comparators connected to each input. The High Range covers thresholds between 1V and 6V in 20mV steps. The Low Range covers thresholds between 0.5V and 3V in 10mV steps. The Adjustable Range covers 0.2V to 1.2V in 4mV steps. Select the negative polarity option in the Adjustable Range when sensing negative voltages. The Adjustable Range is high impedance. If the Adjustable Range is used in conjunction with external resistive dividers, keep the Thevenin divider resistance below 100k to maintain threshold accuracy.

Because there are 750 fixed thresholds per comparator, external resistive dividers are rarely necessary. This keeps part counts low and board layout simple. When monitored

APPLICATIONS INFORMATION

supplies are below 6V, consider using one of the fixed thresholds in any of the three monitoring ranges.

UV and OV Thresholds

Each $V_THRESHOLD_n$ command ($n = 1..6$) configures the UV and OV thresholds for the corresponding input channel. Each command word contains encoding for the OV threshold in the upper byte, and for the UV threshold in the lower byte. Voltage threshold encoding examples are given below the command description.

In the High Range and Low Range modes, the Vn inputs have finite input impedance, and should not be loaded with an external resistive divider. In the Adjustable Range, the Vn inputs are high impedance. Use the adjustable range with or without external resistors to customize thresholds. At each Vn input, the adjustable range senses voltages between 0.2V and 1.2V. External resistors can divide-down larger voltages, and provide level-shifting for negative voltage applications.

UV Thresholds and Sequence-Up Hysteresis

During sequencing-up, systems are subject to large electrical disturbances as loads become energized. Each of the LTC2937 comparators has built-in glitch filtering, and accommodation for short-term sagging in supervised voltages during sequence-up. The UV thresholds on channels selected for sequencing receive temporary hysteresis during sequencing-up. Each UV threshold moves down by 5% (for positive sensing applications) after the voltage first crosses its configured UV threshold. The temporary hysteresis remains effective for $\frac{1}{2}$ of the configured RSTB assertion delay. The RSTB assertion delay commences when the last configured supply rises above its UV threshold for the first time (supplies configured for sequencing and for RSTB logic).

For negative sensing applications, hysteresis moves the UV threshold up by 5%, instead of down. The UV threshold during temporary hysteresis is equal to the programmed threshold. When temporary hysteresis is not active, the UV threshold is 5% below the value configured by the $V_THRESHOLD_n$ word. This is important because the UV threshold used in all negative calculations is 5% below that programmed in the $V_THRESHOLD_n$ word.

If a channel is not combined into the RSTB response, its UV comparator threshold does not move. For positive sensing applications it remains at the value encoded in the $V_THRESHOLD_n$ word, and for negative sensing applications it remains at a value 5% below the value encoded in the $V_THRESHOLD_n$ word.

Selecting Resistors for Adjustable Range

For positive voltage sensing applications, use Figure 11 as a configuration reference. For example, assume a positive input voltage of +15V applied to the top of R2, with a desired UV threshold at 14.3V ($V_{TH(UV)}$). Use the V_RANGE command to select the Positive Adjustable Range. When the input voltage is 14.3V we choose the Vn input to be $V_{MON(UV)} = 1.0V$ (somewhat arbitrarily, for numerical simplicity). $V_{MON(UV)} = 1.0V$ is a code of $uv_threshold_n = 0xCD$ (205). The resistor ratio, $R2/R1$ is easily determined by the equation:

$$\frac{R2}{R1} = \frac{(V_{TH(UV)} - V_{MON(UV)})}{V_{MON(UV)}} = \frac{(14.3V - 1V)}{1V} = 13.3$$

Suitable values are $R1 = 10k$ and $R2 = 133k$. With a Thevenin divider resistance of less than 10k, leakage current in the Vn pin causes less than 0.01% threshold error. Errors in the resistor ratio will produce proportional voltage threshold errors.

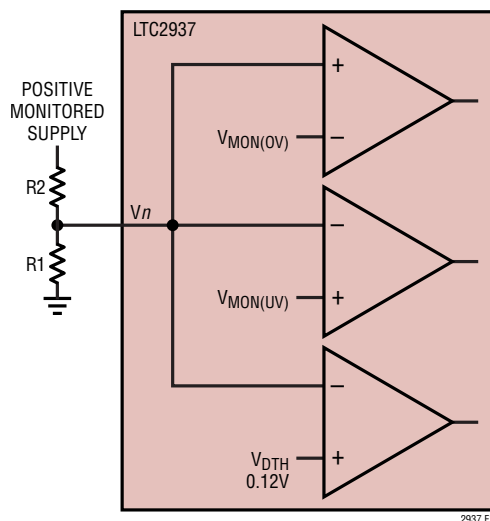

Figure 11. Configuring Custom Positive Thresholds (Operating in the Positive Adjustable Range)

APPLICATIONS INFORMATION

Calculations for negative input voltage applications are more complex due to level shifting and temporary input hysteresis. Use Figure 12 as a configuration reference. Because the voltage at the V_n input must be between 0.2V and 1.2V in the adjustable range (at threshold), a positive level-shifting voltage (V_{LS}) is required. V_{LS} must be stable before the negative voltage pulls down to prevent the V_n input voltage from going below ground. Level-shifting voltage accuracy affects threshold sensing accuracy. Use VDD as a convenient level-shifting voltage when $\pm 2\%$ threshold variation is tolerable. Use a more accurate level-shifting voltage for better than 2% threshold accuracy.

For any negative sensing application, the actual UV comparator threshold is 5% below the value programmed in the $V_THRESHOLD_n$ word. For example, if the UV comparator is programmed for the top of the adjustable range (1.2V), the comparator will trip at a voltage of $0.95 \cdot 1.2V = 1.14V$. This is true whether the supply is participating in sequencing or not. If the supply is participating in sequencing, the temporary hysteresis threshold moves to the value programmed in the $V_THRESHOLD_n$ word.

Consider an example of a negative supply that is not participating in sequencing (no temporary hysteresis). Assume a negative input voltage of $-0.9V$ applied to the bottom of $R1$, and a desired UV threshold voltage of $V_{TH(UV)} = -0.864V$. Use the V_RANGE command to select the Nega-

tive Adjustable Range. When the input voltage is $-0.864V$, we choose the V_n input to be $V_{MON(UV)} = 1.2V$. $V_{MON(UV)} = 1.2V$ is a code of $uv_threshold_n = 0xFF$ (255). The resistor ratio, $R2/R1$ is easily determined by the equation:

$$\frac{R2}{R1} = \frac{V_{LS} - 0.95 \cdot V_{MON(UV)}}{0.95 \cdot V_{MON(UV)} - V_{TH(UV)}}$$

$$\frac{3.3V - 1.14V}{1.14V + 0.864V} \approx 1.078$$

Suitable choices for $R2 = 22.1k$ and $R1 = 20.5k$.

As a final example, consider the case of the negative supply participating in sequencing. Keep the UV threshold $V_{TH(UV)} = -0.864V$, and select 5% temporary hysteresis ($H=0.05$). Select the monitor threshold $V_{MON(UV)} = 0.748V$ ($uv_threshold_n = 0x8E$ (142)). $R2/R1$ is given by:

$$\frac{R2}{R1} = \frac{V_{LS} - V_{MON(UV)}}{V_{MON(UV)} - V_{TH(UV)} \cdot (1-H)}$$

$$\frac{R2}{R1} = \frac{3.3V - 0.748V}{0.748V + 0.864V \cdot 0.95} \approx 1.626$$

Suitable resistor values are $R2 = 17.4k$ and $R1 = 10.7k$.

OV Thresholds in Adjustable Applications

After selecting external resistors, configure the OV thresholds. Following the positive adjustable example of Figure 11, the monitor comparator OV threshold is determined from:

$$V_{MON(OV)} = \frac{V_{TH(OV)}}{1 + \frac{R2}{R1}}$$

Choosing a 10% overvoltage threshold, $V_{TH(OV)} = (15V \cdot 1.1) = 16.5V$. The monitor threshold becomes:

$$V_{MON(OV)} = \frac{16.5V}{1 + \frac{133k}{10k}} \approx 1.154V$$

The closest comparator code ($ov_threshold_n$) is $0xE3$ (243).

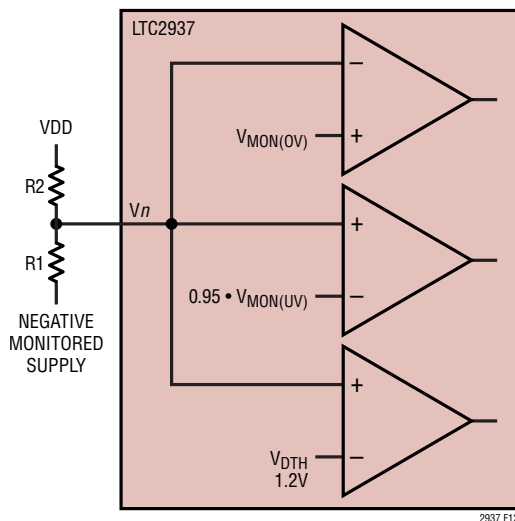

Figure 12. Configuring Custom Negative Thresholds (Operating in the Negative Adjustable Range)

APPLICATIONS INFORMATION

Following the negative adjustable example of Figure 12, the monitor comparator OV threshold is determined from:

$$V_{\text{MON(OV)}} = \frac{V_{\text{LS}} + \frac{R2}{R1} \cdot V_{\text{TH(OV)}}}{1 + \frac{R2}{R1}}$$

Choosing a 10% overvoltage threshold:

$$V_{\text{TH(OV)}} = (-0.9\text{V} \cdot 1.1) = -0.99\text{V}$$

The monitor threshold becomes:

$$V_{\text{MON(OV)}} = \frac{3.3\text{V} + \frac{17.4\text{k}}{10.7\text{k}} \cdot (-0.99\text{V})}{1 + \frac{17.4\text{k}}{10.7\text{k}}} \approx 0.644\text{V}$$

The closest comparator code (`ov_threshold_n`) is 0x74 (116).

RSTB Response

Tie RSTB to any device requiring a reset signal. RSTB is low when any selected voltage monitor violates its respective threshold. RSTB is allowed to pull high when all selected voltages are in compliance (UV and/or OV) and the assertion delay has expired. An external pull-up resistor (10k to 100k) is recommended. Use the RSTB_CONFIG command to configure RSTB response. Combine any voltage monitor input into the RSTB response whether or not

the channel is participating in sequencing. If there are no channels selected, RSTB is affected only by the device's internal undervoltage lockout and initialization circuits. The assertion delay remains active. After initial application of device power, RSTB assertion delay cannot start until device configuration is complete. The configuration (or restore) time (t_{RT}) is a maximum of 2ms after crossing VDD undervoltage lockout (V_{UVL}).

Force RSTB high anytime by pulling the MARGB input low. MARGB overrides the RSTB function and is typically used while system voltages are margined high or low and a device reset is not desired. The RSTB override may also be controlled with I²C writes to b[6] of the ON_OFF_CONTROL register.

Sequence-Down Parameters

Sequence-down configuration consists of defining the sequence position for each sequenced supply, the time delay to enable pulling low (measured from the falling edge of SPCLK) and the maximum allowed elapsed time (from enable) for each sequenced supply to reach its discharge threshold. Configure these parameters with the SEQ_DOWN_POSITION_n and TOFF_TIMERS_n commands (where n denotes the channel number). Figure 13 graphically depicts parameters for a hypothetical supply operating in channel 1. Sequencing is initiated with the ON input. In this example, the supply is disabled in sequence position 2, with an enable delay (toff_delay_1) of 800 μs

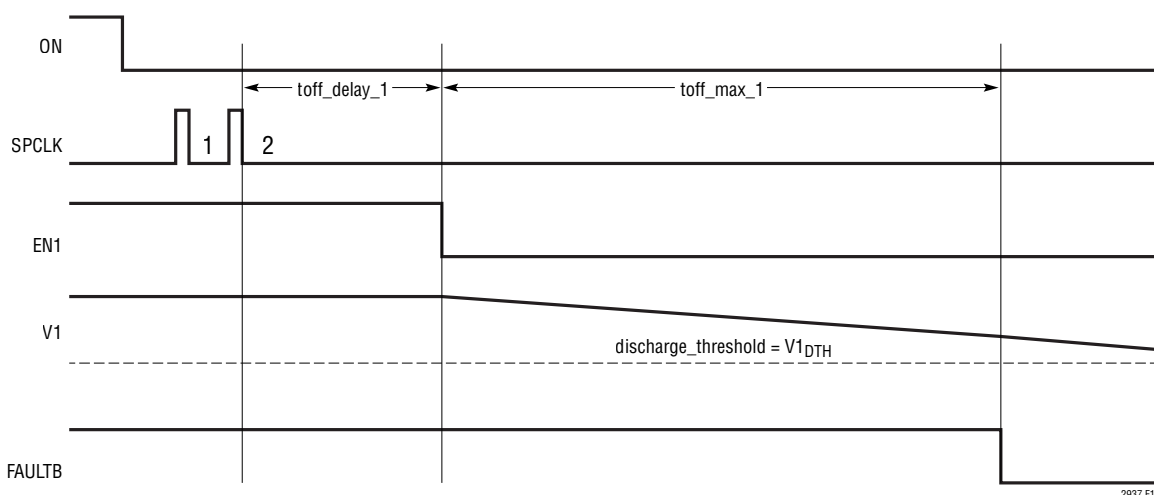

Figure 13. Sequence-Down Timing Parameters (V1 Set to Sequence Down in Sequence Position 2)

APPLICATIONS INFORMATION

and a maximum fall time (`toff_max_1`) of 10.24ms. Because V1 does not meet its fall time requirements (V1 is above the discharge threshold when `toff_max` is reached), a sequence-down fault occurs and all enables are turned off. The corresponding command register values are:

`SEQ_DOWN_POSITION_1 = 0x0002`

`TOFF_TIMERS_1 = 0x4064`

Two options exist for triggering sequence position advancement during the sequence-down phase of operation. `ON_OFF_CONTROL` register bit `b[0]` determines the trigger method. The first option (`b[0] = 0`) allows sequence position advancement on the basis of voltage decay, and applies to all sequenced supplies. A supply (or supplies) that has been commanded off in a particular sequence position is required to fall below its discharge threshold before system advancement to the next sequence position (Figure 13). The decay must occur before the `toff_max` time has transpired. The second option (`b[0] = 1`) allows sequence position advancement on the basis of time delay. The time delay is equal to the configured `toff_max` time. If `toff_max` is set to ∞ , operation reverts back to voltage decay mode.

Discharge Thresholds

The LTC2937 monitor inputs have discharge monitor comparators with thresholds used to determine if a monitored supply is substantially discharged when in the off state. This feature is used in two ways. First, prevent the start of sequencing-up if any supply scheduled for sequencing is above its discharge threshold. Enable this qualification with `b[5]` in the `ON_OFF_CONTROL` register. Second, as discussed above, use `b[0]` to allow sequence-down advancement when the disabled supplies have decayed below their discharge threshold. Read the combined discharge status for sequenced channels from `b[2]` in the `STATUS_INFORMATION` register.

The selected voltage range for each monitor input determines the respective discharge threshold value at the monitor input. Operating in the high or low range sets the discharge threshold V_{DTH} to 400mV. Operating in the positive adjustable range sets the discharge threshold V_{DTH}

to 120mV. In the negative adjustable range, the discharge threshold V_{DTH} is 1.2V.

The adjustable ranges are often used in conjunction with external resistive dividers to configure custom thresholds as described earlier. For positive adjustable applications, the discharge threshold (DT) referred to the input voltage is

$$DT = V_{TH(UV)} \cdot \frac{V_{DTH}}{V_{MON(UV)}}$$

Applying values from the example using Figure 11, the discharge threshold is:

$$DT = 14.3V \cdot \frac{0.12V}{1V} = 1.716V$$

For negative adjustable applications, the discharge threshold (DT) referred to the negative input voltage is

$$DT = V_{DTH} - \frac{(V_{LS} - V_{DTH})}{\frac{R2}{R1}}$$

Applying values from the example using Figure 12, the discharge threshold is:

$$DT = 1.2V - \frac{(3.3V - 1.2V)}{\frac{17.4k}{10.7k}} = -0.091V$$

Active Supply Discharge

When power supplies are commanded off, system load characteristics and bulk capacitance can make it difficult to discharge supply voltages to a low level quickly. Use the active supply discharge feature to reduce discharge time. Apply `b[10]` of the respective `SEQ_DOWN_POSITION_n` register to enable the 30mA pull-down current. The pull-down current is always active while the respective supply is off (enable low). The discharge feature is best used in monitor applications that do not have an external resistive divider at the monitor input. CAUTION: Applying active discharge through a divider network in positive or negative voltage applications can cause a false sense of discharge at the monitor input.

APPLICATIONS INFORMATION

Fault Descriptions

Various faults can be detected during system operation. First fault information is logged to EEPROM. Program fault response actions using the FAULT_RESPONSE command. Actions include total shutdown with optional restart, system freeze and ignore. Faults can occur due to sequence control violations (CONTROL fault), sequence-up and sequence-down violations, voltage threshold violations, external inputs and loss of SHARE_CLK.

CONTROL Faults

A sequence-up or sequence-down phase is initiated by an ON input change of state and/or i2c_on_off bit state change. After the sequence-up phase has commenced, the ON input and/or i2c_on_off bit must remain in the same state until all sequenced supplies have reached their undervoltage threshold.

Similarly, after the sequence-down phase has commenced, the ON input and/or i2c_on_off bit must remain in the same state until all sequenced supplies have reached their discharge threshold.

A change of sequence control state during sequencing operations is considered a CONTROL fault. A CONTROL fault causes all enable outputs to pull low immediately. The FAULTB output pulls low in response to any CONTROL fault. The reporting of CONTROL fault status is described below in the Fault Reporting section.

To force a shutdown at any time, create an intentional CONTROL fault by toggling the ON input. The width of the ON pulse must be greater than 25 μ s in order to be detected.

SEQUENCE Faults

Each of the six channels has a dedicated timer defining maximum turn-on and turn-off time for each sequenced voltage, used to protect against stalled power supplies. Any enabled supply that fails to exceed its sequence threshold before its timer expires will cause a SEQUENCE fault. A SEQUENCE fault causes all enable outputs to pull low immediately. The FAULTB output pulls low in response to any SEQUENCE fault. The reporting of SEQUENCE fault status is described below in the Fault Reporting section.

SUPERVISOR Faults

It is important to understand the difference between a SUPERVISOR fault and the RSTB output response. Using the RSTB_CONFIG command (0x22), UV and OV comparator outputs combine to form the RSTB response. The RSTB output is always active (unless masked during margining). SUPERVISOR faults are generated from the same set of selected UV and OV comparators. However, a SUPERVISOR fault is active only under a restricted set of operating conditions.

SUPERVISOR faults are allowed to occur when the system is in the sequence-up phase or supervisory phase of operation. These phases reside within the time region bracketed by ON input changes of state (rising ON to falling ON under default polarity). Furthermore, UV comparator contributions to a SUPERVISOR fault are only active after the sensed voltages have crossed their UV threshold for the first time. OV comparator contributions are active throughout the sequence-up and supervisory phases of operation. In the event of a SUPERVISOR fault, it may be desirable to turn off all sequenced supplies. Set b[12] = 1 in the RSTB_CONFIG register (0x22), to allow the FAULTB output to pull low in response to a SUPERVISOR fault. All sequenced enable outputs pull low when the fault is generated. The reporting of SUPERVISOR fault status is described below in the Fault Reporting section.

EXTERNAL Faults

It may be desirable to turn off enabled supplies on the basis of an external event. Apply an external signal to pull down on FAULTB and force a shutdown event if b[9] of the FAULT_RESPONSE register is set to a logic 1. To ignore external pull downs on FAULTB, set b[9] to logic 0. The reporting of EXTERNAL fault status is described below in the Fault Reporting section.

SHARE_CLK Faults

If SHARE_CLK becomes inactive for more than 32 μ s after it has initially started to operate, a fault is automatically generated. The fault causes FAULTB to pull low. All enable outputs pull low when the SHARE_CLK fault is generated. The reporting of SHARE_CLK fault status is described below in the Fault Reporting section.

APPLICATIONS INFORMATION

Fault Reporting

Retrieve important fault information from the following useful registers:

- STATUS_INFORMATION (0x29)
- MONITOR_STATUS (0x30)
- MONITOR_STATUS_HISTORY (0x26)
- MONITOR_BACKUP (0x2F)

Obtain device status with an I²C read word operation from STATUS_INFORMATION (command address 0x29). Embed the read operation in a software loop for continuous polling. Otherwise, read the register on an as needed basis, for example after ALERTB or FAULTB has pulled low. Fault related data in STATUS_INFORMATION includes:

- SEQUENCE fault channel number
- Monitor backup status
- Sequence-up fault status
- Sequence-down fault status
- OV fault status
- UV fault status
- SUPERVISOR fault status
- CONTROL fault status
- EXTERNAL or SHARE_CLK fault status

Device status at the time of a fault is latched into STATUS_INFORMATION (except for the discharge status in b[2]). This implies that although the system may be commanded off and in the sequence-down state (due to a fault), the STATUS_INFORMATION register will not necessarily indicate sequence-down status. The STATUS_INFORMATION register retains the state of the device at the time of the fault until the beginning of the next sequence-up operation, or until cleared.

Other non-fault related data contained in STATUS_INFORMATION includes sequence region status and discharge level status. A valid sequence-up initiation automatically clears STATUS_INFORMATION.

A summary of the present (live) voltage monitor conditions and external status of RSTB is available from the MONITOR_STATUS register.

Retrieve a summary of collected SUPERVISOR and SEQUENCE faults with a read from MONITOR_STATUS_HISTORY. If two or more supplies have simultaneous SEQUENCE faults, the sequence fault is reported with the lowest numbered channel having report priority. SUPERVISOR faults can only occur through comparators mapped to the reset logic. A valid sequence-up initiation automatically clears the MONITOR_STATUS_HISTORY. Use the CLEAR command (0x2E) to reset the history contents to the defaults.

The MONITOR_BACKUP register mirrors the contents of the MONITOR_STATUS_HISTORY upon the first detected SEQUENCE or SUPERVISOR fault. Subsequent faults are not stored so that the first fault can always be retrieved even after complete device power cycling. If device power has not been cycled, retrieve the backup word by issuing a RESTORE command followed by a MONITOR_BACKUP read operation. Clear the backup word by performing a CLEAR command followed by a STORE command. After a device power cycle, MONITOR_BACKUP updates automatically, so a RESTORE command is not required prior to a MONITOR_BACKUP read. After any device power cycle or CLEAR command, backup register contents are directly modified by the next SUPERVISOR or SEQUENCE fault. Monitoring b[12] of the STATUS_INFORMATION register alerts the existence of a logged fault.

Fault Management

In the event of a fault, a variety of responses can be configured in the FAULT_RESPONSE register (0x23). Response actions include:

- Shut-down and stay off.
- Shut-down and restart after discharging supplies.
- Shut-down and restart after a time delay.
- Shut-down and restart after discharging supplies and time delay.
- Continue operation.
- Freeze system in current state.

APPLICATIONS INFORMATION

Some applications require the ability to retry operation after a shut-down event. Specify the automatic retry count in the FAULT_RESPONSE register (0x23) with b[2:0]. Retry counts can be set to zero, range from one to six, or be unlimited. When configured for retry operation, leave the sequencing control (ON input or I²C directive) in the sequence-up state, unless a sequence-down operation is required. Retries do not occur in response to faults during the sequence-down phase of operation.

The zero retry option is useful when a new system requires some debug or adjustments after initial application of sequenced power. If power supply turn-on does not meet requirements, the fault response action of simply shutting down supplies and remaining off allows for status register inspections without the risk of re-energizing loads improperly. The status information helps determine the source of failure. Re-sequencing is permitted after the ON input has been taken to the sequence-down level and retry conditions specified in b[4:3] have been satisfied.

Some systems can tolerate retry attempts after failed operation. In the one to six retry mode, the retry counter can be read to retrieve the number of attempted retries. With the ON input at the sequence-up level, the retry counter is never cleared automatically. The retry counter is cleared to zero after the ON input has been taken to the sequence-down level and retry conditions have been satisfied.

With unlimited retries selected, retries are attempted continuously, until commanded off (by the ON input, I²C bus or both), device power is removed, or another fault condition causes the device to turn off the power supply enable signals. The retry counter does not count in infinite retry mode.

Certain criteria must be satisfied before a retry occurs. For example, all sequenced supplies may be required to be below their discharge threshold before a retry occurs. This ensures that sequencing begins only after all sequenced supplies have returned to a low voltage level. After a fault, all sequenced enable outputs turn off immediately. FAULTB pulls low if required. Automatic retries are allowed after sequenced voltages have decayed below their discharge thresholds.

Alternatively, allow retries after a specified time delay. Select 1 of 8 time delays between 50 μ s and 13 seconds. The use of time delay can allow overheated components to drop in temperature before a retry is attempted. After a fault, all sequenced enable outputs turn off immediately. FAULTB pulls low if required. Automatic retries are allowed after the time period specified in b[7:5].

Automatic retries do not occur in the case of CONTROL faults, however CONTROL faults can occur during retry operations. If desired, retries may require both discharge and time delay. The combined discharge and time delay feature is only available when using automatic retries.

The FAULT_RESPONSE register reports the number of retries attempted in b[13:11]. The count is updated when the retry criteria discussed above are met. In a system with multiple LTC2937s, retry counts can differ among devices if some devices have met retry criteria and others have not. If the number of retries allowed is unlimited, the retry counter reports a value of zero.

Avoid changing the allowed number of retries while sequencing control is in the sequence-up state to prevent unintended operation. To safely change configuration, place sequencing control into the sequence-down state, perform a CLEAR operation and then make changes to the retry number.

Systems that experience complete shutdown after a fault can be difficult to debug because the power is gone. The continue and freeze fault response actions can be useful when debugging system problems, because power supplies remain on, allowing for meaningful measurements. However, use caution when applying the continue and freeze modes because some loads are highly sensitive to the applied supply voltages and, if one or more voltages are incorrectly applied, damage to a load may result.

In the continue mode, there is no shutdown except in the case of a CONTROL fault. Information is logged to status registers and a FAULTB output is generated, but shutdown procedures do not take place. EXTERNAL faults are ignored. SPCLK attempts to operate, so a complete sequence-up process can occur even if one or more supplies have a problem. To prepare for restart after a fault in continue mode, bring the ON input to the sequence-down state and perform a CLEAR operation.

APPLICATIONS INFORMATION

In the freeze mode, fault information is logged to status registers and a FAULTB output is generated, but shutdown procedures do not take place. If the fault occurs during sequencing, SPCLK stops and does not advance further. SHARE_CLK continues to operate normally. ON input state changes are ignored after the original fault. If both freeze mode and continue mode are selected, freeze mode takes precedence. Exit from a freeze condition by setting b[8] = 0 in the FAULT_RESPONSE register (provided that continue mode is not selected) or perform a CLEAR operation. These actions cause enable outputs to pull low, returning the system to a shut-down state.

Fault Debugging Tools

While STATUS_INFORMATION, FAULT_RESPONSE, MONITOR_STATUS_HISTORY, MONITOR_STATUS and MONITOR_BACKUP provide insight into system behavior, additional commands and functions are available to assist with system debug. These include:

- BREAK_POINT (0x2A)
- SEQ_POSITION_COUNT (0x2B)
- SMBus Alert Response Address

The break point feature holds the system at user specified sequence positions during SPCLK low periods. Set sequence position break points in the sequence-up or sequence-down phase of operation. Enable break point usage with bp_enable b[10]. With break point usage enabled, a valid control input (ON transition or I²C command) will sequence the device until sp_count in the SEQ_POSITION_COUNT register is equal to bp_value in the BREAK_POINT register. Perform register inspections and system measurements at each paused sequence position. Increment the BREAK_POINT register repeatedly for controlled single stepping through all sequence positions. SPCLK holds low until bp_value is changed to be not equal to sp_count or bp_enable is set low. The sequencing enable delay timers and maximum rise/fall timers function normally at each sequence position.

Knowing the sequence position after a fault can help identify problems. Read the current sequence position count contained in the sp_count bit field of the SEQ_POSITION_COUNT register. The sp_count bit field

is zero after initial application of device power or after a CLEAR command. At the conclusion of all sequence-up or sequence-down operations, sp_count increments by one. For example, if the last configured sequence position is 10, sp_count increments to 11 when the sequencing operation completes. If the last sequence position is 1023, sp_count rolls over to zero at the end of sequencing. After a fault (whether in break point mode or normal operation), the current sequence position value is reported until the fault exit conditions are satisfied.

The ALERTB output pulls low in response to any fault. Connect ALERTB as an interrupt to a host processor. The host can access all devices through the Alert Response Address. Only the devices which asserted their ALERTB will acknowledge the Alert Response Address. If more than one device is alerting, the device with the lowest address will return its address as data. After acknowledging the slave address, the slave device releases pull-down on ALERTB. If the host recognizes that ALERTB remains low due to another device, it can read the alert response address again.

The ALERTB output pull-down may also be removed by performing a read from the CLEAR_ALERTB register. All other status information remains unaffected. The returned data word contains no useful information and the contents should be ignored. Faults may persist even though ALERTB is cleared.

Share Clock (SHARE_CLK)

Synchronize multiple LTC2937s (and any other LTC device with a SHARE_CLK function) in an application by connecting together the open-drain SHARE_CLK input/outputs to a pull-up resistor as a wired OR. A single 3.3k resistor is recommended. The fastest clock will take over and synchronize timing on all devices.

Asynchronous Supply Control

Any supply controlled by an LTC2937 enable output may be asynchronously commanded on or off. Activate this capability by setting the respective b[9:0] = 0 in SEQ_UP_POSITION_n or SEQ_DOWN_POSITION_n. To release the enable pull-down and turn on the controlled

APPLICATIONS INFORMATION

supply, write $b[10] = 1$ in $SEQ_UP_POSITION_n$. To shut off the supply, write $b[10] = 0$.

A supply may be asynchronously turned on before or after sequence-up operations. It is not recommended to turn on supplies asynchronously during sequence-up operations. If a supply has been turned on before sequencing, its respective monitor input will be checked for UV compliance in sequence position 1. If the monitor input is not above its configured UV threshold before its respective ton_max time has elapsed (measured from the start of sequence position 1), a SEQUENCE fault is generated.

The UV and OV comparator outputs from asynchronously enabled channels may be combined into the RSTB response. Furthermore, if the asynchronous channel is enabled prior to sequencing-up and combined into the RSTB response, it will also contribute to SUPERVISOR faults if the monitored voltage falls back below its UV threshold after sequence-up operations have started.

If an asynchronous channel is enabled after sequencing-up is complete, its UV and OV comparator outputs can still be combined into the RSTB response. However, the comparators will not contribute to SUPERVISOR faults.

After sequence-down operations have completed, a CLEAR command must be issued prior to assigning any asynchronously operated channel a position in the sequencing order.

To use the LTC2937 as a simple multi-channel voltage supervisor without sequencing, configure all contributing channels to be asynchronously enabled and configure unused channels for sequence position zero. Select channels to be combined into the RSTB and optional SUPERVISOR fault responses.

LTpowerPlay: An Interactive GUI for Power System Management

LTpowerPlay is a powerful Windows based development environment that supports Linear Technology power system manager ICs with EEPROM, including the LTC2937 6-channel sequencer and voltage supervisor. The software supports a variety of different tasks. You can use LTpowerPlay to evaluate Linear Technology ICs by connecting to a demo board system. LTpowerPlay can also be used in an offline mode (with no hardware present) in order to build a multichip configuration file that

can be saved and reloaded at a later time. LTpowerPlay provides unprecedented diagnostic and debug features. It becomes a valuable diagnostic tool during board bring-up to program or tweak the power management scheme in a system or to diagnose power issues when bringing up rails. LTpowerPlay utilizes Linear Technology's DC1613 USB-to-I²C/SMBus/PMBus Controller to communicate with one of many potential targets, including the DC2313 demo board set, the DC2347 socketed programming board, or a customer target system. The software also provides an automatic update feature to keep the software current with the latest set of device drivers and documentation. A great deal of context sensitive help is available within LTpowerPlay along with several tutorial demos. Complete information is available at: www.analog.com/en/design-center/ltpower-play.

External Connection Design Checklist

- Apply device power through VPWR or VDD and ground. If powered through VPWR, place 2.2 μ F (or greater) compensation capacitor between VDD and GND.
- Tie unused V_n inputs to GND.
- Have control of WP if needed for device programming.
- Have control of ON if needed for sequencing.
- Have control of MARGB if needed for voltage margining operations.
- Use pull-up resistors to EN_n as needed (10k to 100k).
- Apply pull-up resistor to SHARE_CLK (3.3k to 10k) and connect to other SHARE_CLK nodes as needed.
- Connect SPCLK to other SPCLK nodes as needed. Do not apply pull-up resistors.
- Use pull-up resistors to RSTB, FAULTB and ALERTB as needed (10k to 100k).
- If using I²C for programming and/or read back:
 - Configure device address with $ASEL_n$ inputs.
 - Check addresses for collision with other devices on the I²C bus.
- Verify logic level compatibility for all I/O between LTC2937 and other devices.

APPLICATIONS INFORMATION

Minimum Connections for Programming

For users interested in performing their own programming, Figure 14 shows the minimum recommended connections for a programming socket. Make sure that the SCL and SDA levels match the VDD level. Set the software lock bit to 0 in the WRITE_PROTECTION register before writing new register values. Changing the software lock bit from a 1 to 0 requires matching the key string in b[15:2]. A socketed programming board is available for use with the LTpowerPlay system.

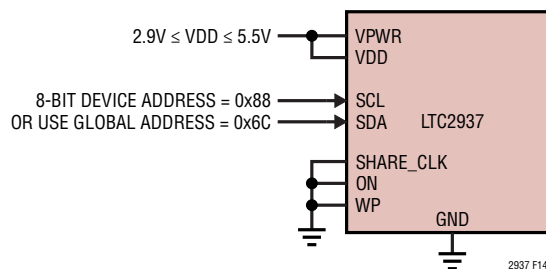

Figure 14. Programming Socket Connections

Interconnect Between Multiple LTC2937s

Figure 15 shows how to interconnect the pins in a typical multi-LTC2937 array. In this example, device power is derived from an intermediate bus voltage. It is recommended that SPCLK, SHARE_CLK and ON are tied together. Optional interconnections include RSTB, FAULTB, MARGB, ALERTB, SDA and SCL. Connect FAULTB lines together with external fault listening enabled to allow any one fault to shut off all power supplies. The host controller asserts ON for sequencing control and listens to ALERTB to gain information about system faults.

System Event Based Sequencing

The schematic shown on the back page demonstrates how power sequences can be coordinated in a system of systems. A logic output from System 1 (READY) is used as a gating input to the sequence order. System 2 does not sequence-up until System 1 is qualified by the LTC2937.

APPLICATIONS INFORMATION

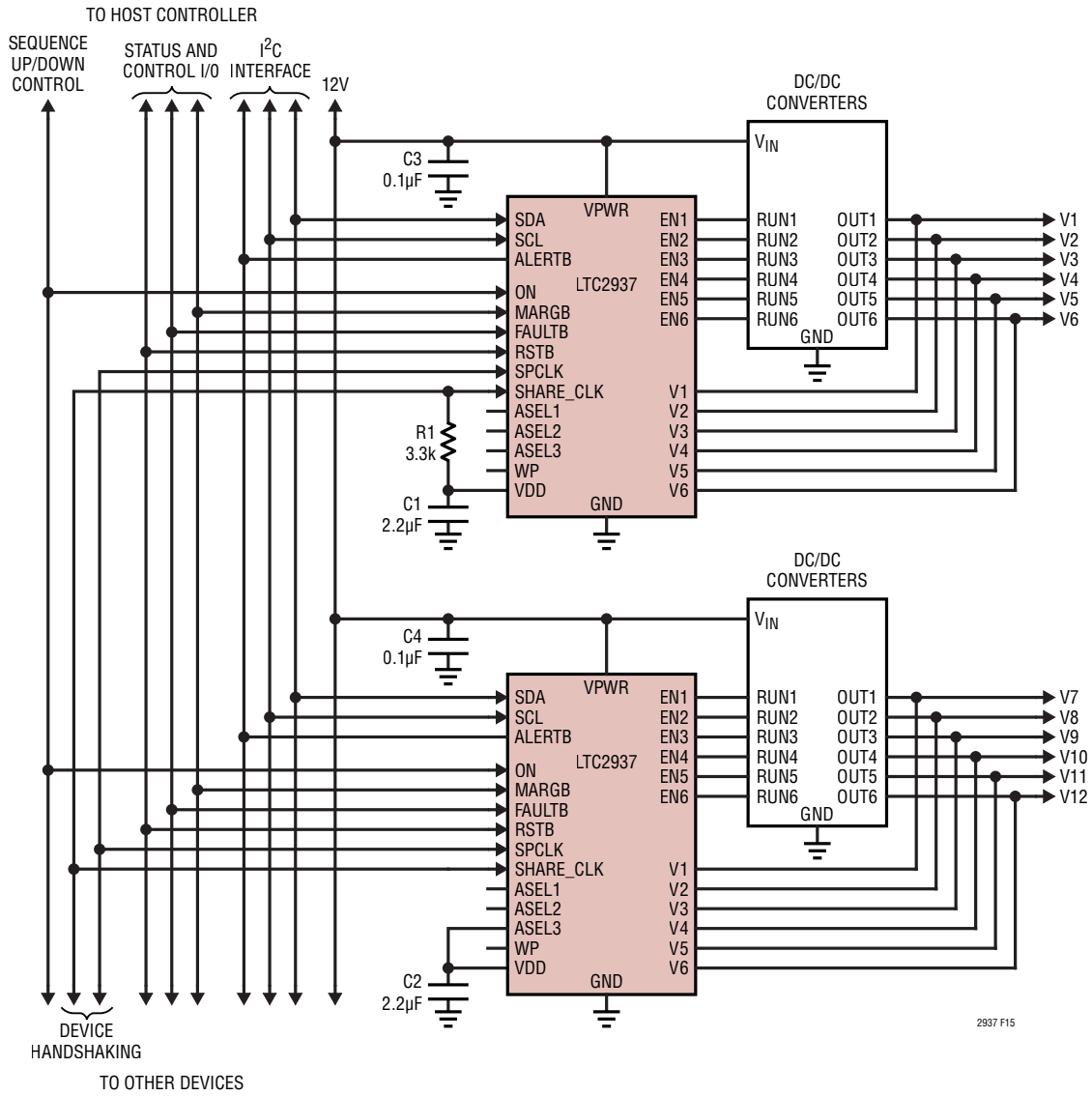

Figure 15. Typical Connections Between Multiple LTC2937s

REVISION HISTORY

| REV | DATE | DESCRIPTION | PAGE NUMBER |
|-----|-------|---|------------------------------|
| A | 08/16 | Added H-grade information Updated specification limits to accommodate H-grade: V_{UVL} , R_{IN} , I_{LKG} , $I_{AD(MAX)}$, t_{PT} , t_{RST} , t_{ON_MAX} , t_{OND} , t_{OFF_MAX} , t_{OFFD} , t_{LO} , t_{HI} , t_{FLOAT} , f_{SHR} , ASEL Input Resistance Updated curves showing temperature variation | 1, 3, 4 4, 5, 6 10, 11 |
| B | 06/19 | Added MP-grade information | 3, 4, 10, 11 |