

LTM4710-1  
Low  $V_{IN}$ , Quad 8A Silent Switcher  
 $\mu$ Module Regulator

**DESCRIPTION**

Demonstration circuit 3164A-B features the [LTM<sup>®</sup>4710-1](#), a quad DC/DC step-down  $\mu$ Module<sup>®</sup> regulator with 8A per output, packaged in a compact (6mm  $\times$  12mm  $\times$  3.54mm) land grid array (LGA) with pre-made solder balls. DC3164A-B has an operating input range of 2.5V to 5.5V. The outputs of the four channels are 0.8V, 1.0V, 1.2V, and 1.5V with 8A per output, respectively. All outputs voltages are programmable from 0.5V up to 3.6V (step-down only). DC3164A-B operates by default at 1.5MHz and can be adjusted by an external resistor from 1MHz to 5MHz or by being synchronized to an external clock from 1.2MHz to 2.6MHz. DC3164A-B also allows for the channels to be paralleled up to 32A load current.

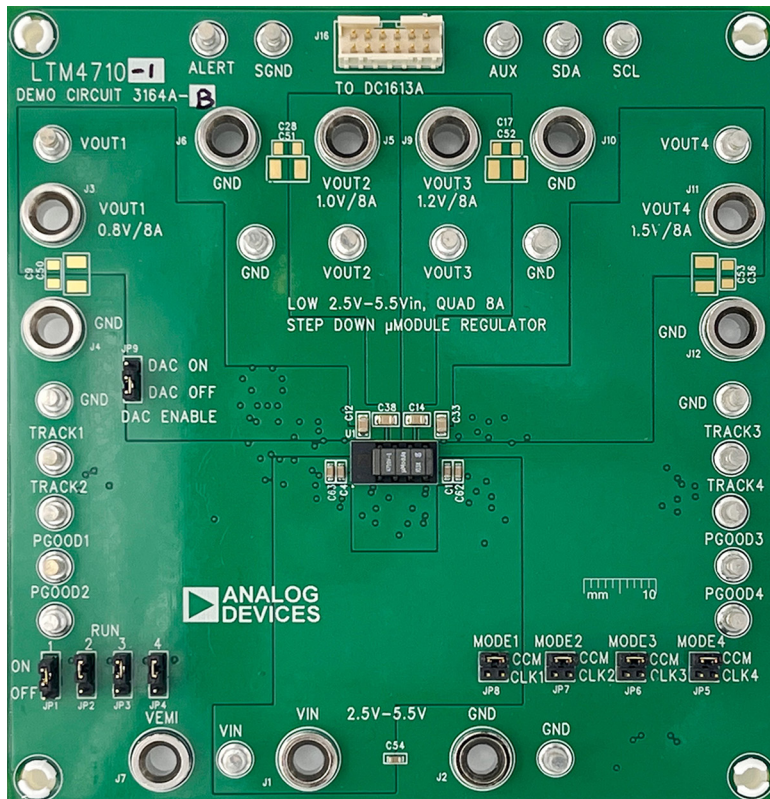
LTM4710-1 integrates four separate constant-frequency peak current mode control regulators, power MOSFETs, inductors, and other supporting discrete components. It employs the second-generation Silent Switcher<sup>®</sup> technology in which it allows fast switching edges for high efficiency at high switching frequencies, while simultaneously achieving good EMI performance. Refer to the LTM4710-1 data sheet for more detailed information.

It is recommended to read the data sheet of the LTM4710-1 prior to making any changes to the DC3164A-B board.

[Design files for this circuit board are available.](#)

All registered trademarks and trademarks are the property of their respective owners.

**BOARD PHOTO** Part marking is either ink mark or laser mark



# DEMO MANUAL DC3164A-B

## PERFORMANCE SUMMARY Specifications are at $T_A = 25^\circ\text{C}$ , no forced-air cooling

PARAMETER	CONDITIONS	MIN	TYP	MAX	UNITS
Input Voltage Range $V_{IN}$		2.5		5.5	V
Default Switching Frequency			1.5		MHz
Maximum Output Current	For Each Channel		8		A
Output Voltage of Channel 1, $V_{OUT1}$			0.8		V
Output Voltage of Channel 2, $V_{OUT2}$			1.0		V
Output Voltage of Channel 3, $V_{OUT3}$			1.2		V
Output Voltage of Channel 4, $V_{OUT4}$			1.5		V
Efficiency of Channel 1	$V_{IN} = 3.3\text{V}$ , $f_{SW} = 1.5\text{MHz}$ , $V_{OUT1} = 0.8\text{V}$ , $I_{OUT1} = 8\text{A}$		85.1		%
Efficiency of Channel 2	$V_{IN} = 3.3\text{V}$ , $f_{SW} = 1.5\text{MHz}$ , $V_{OUT2} = 1.0\text{V}$ , $I_{OUT2} = 8\text{A}$		85.8		%
Efficiency of Channel 3	$V_{IN} = 3.3\text{V}$ , $f_{SW} = 1.5\text{MHz}$ , $V_{OUT3} = 1.2\text{V}$ , $I_{OUT3} = 8\text{A}$		87.8		%
Efficiency of Channel 4	$V_{IN} = 3.3\text{V}$ , $f_{SW} = 1.5\text{MHz}$ , $V_{OUT4} = 1.5\text{V}$ , $I_{OUT4} = 8\text{A}$		89.2		%

## QUICK START PROCEDURE

Demonstration circuit 3164A-B is easy to set up to evaluate the performance of the LTM4710-1. See Figure 1 for the proper measurement equipment setup and follow the procedure below.

- With power off, place the jumpers as shown in the following positions.

NAME	POSITION	NAME	POSITION
RUN1	ON	MODE1	CCM
RUN2	ON	MODE2	CCM
RUN3	ON	MODE3	CCM
RUN4	ON	MODE4	CCM
DAC ENABLE	OFF		

- With power off, (see Figure 1), connect the input power supply between  $V_{IN}$  and GND. Connect the output loads between  $V_{OUT1}$  and GND,  $V_{OUT2}$  and GND,  $V_{OUT3}$  and GND, and  $V_{OUT4}$  and GND, respectively.
- Connect the DMMs to the input and outputs.
- Turn on the input power supply.

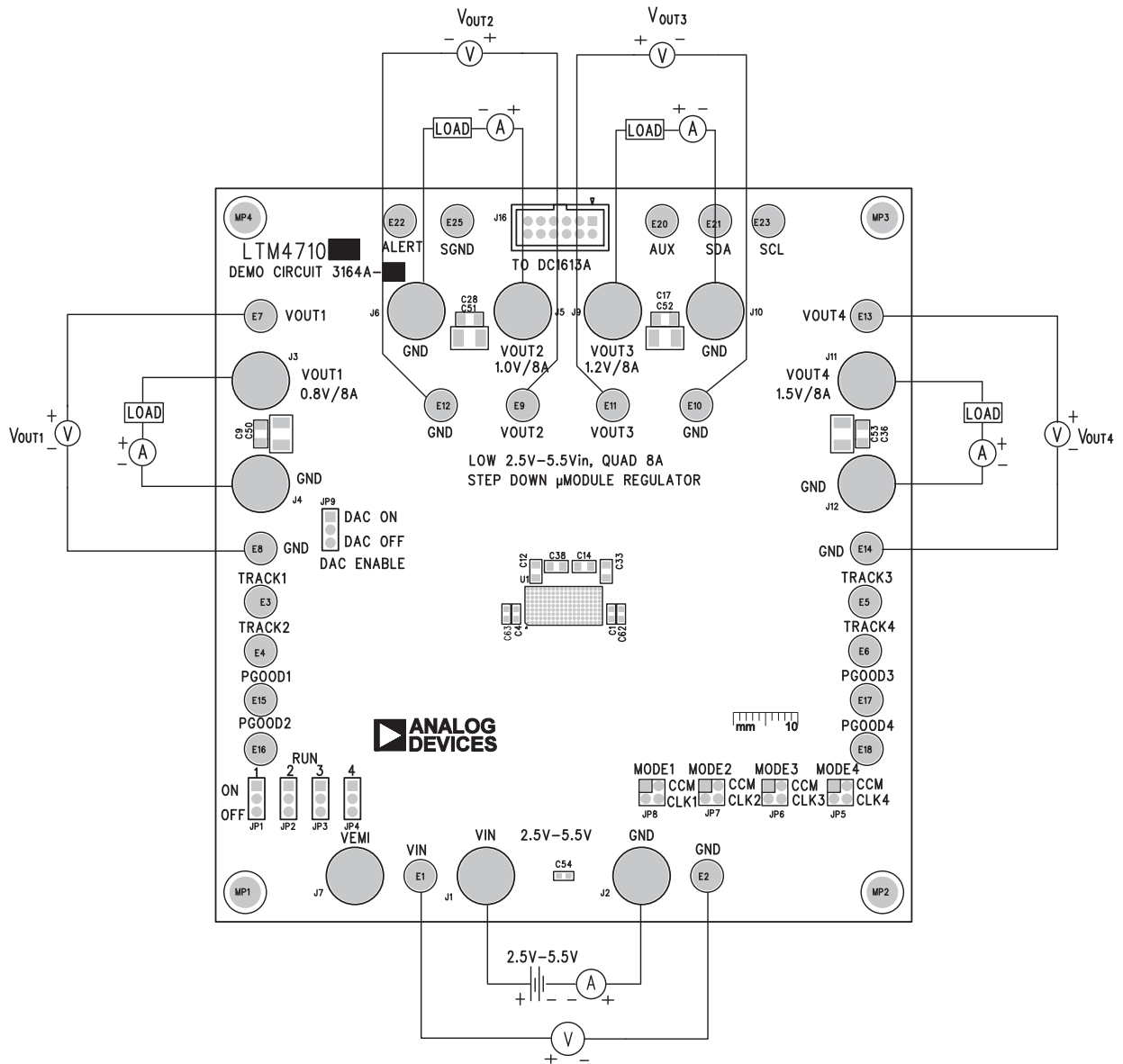
NOTE: The input voltage should be between 2.5V and 5.5V.

- Check for the proper output voltages. The output voltage meters for each channel should display the programmed output voltages ( $V_{OUT1} = 0.8\text{V}$ ,  $V_{OUT2} = 1.0\text{V}$ ,  $V_{OUT3} = 1.2\text{V}$ ,  $V_{OUT4} = 1.5\text{V}$ ) within  $\pm 1.5\%$ .
- Once the input and output voltages are properly established, adjust the load current within the operating range of 0A to 8A max for each channel. Observe the output voltage regulation, output voltage ripples, load transient response and other parameters.
- Vary the input voltage from 2.5V to 5.5V. Observe the output voltage regulation.

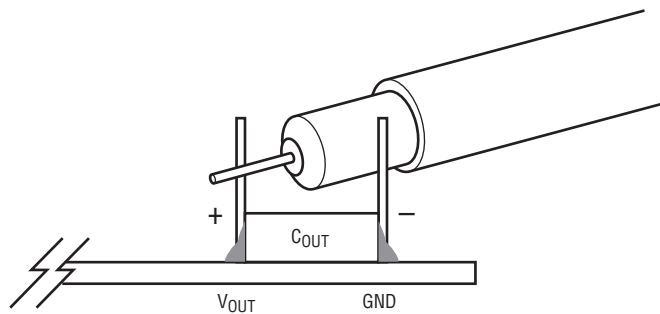
NOTE: When measuring the output or input voltage ripple, do not use the long ground lead on the oscilloscope probe. See Figure 2 for the proper scope probe technique. Short, stiff leads need to be soldered to the (+) and (-) terminals of an output capacitor. The probe's ground ring needs to touch the (-) lead and the probe tip needs to touch the (+) lead.

OPTIONAL: An input EMI filter is included on the board. To include this filter, connect the input supply positive terminal to VEMI. Connect the input positive supply to  $V_{IN}$  to exclude the input EMI filter.

**QUICK START PROCEDURE**



**Figure 1. Proper Measurement Equipment Setup**



**Figure 2. Measuring Output Voltage Ripple**

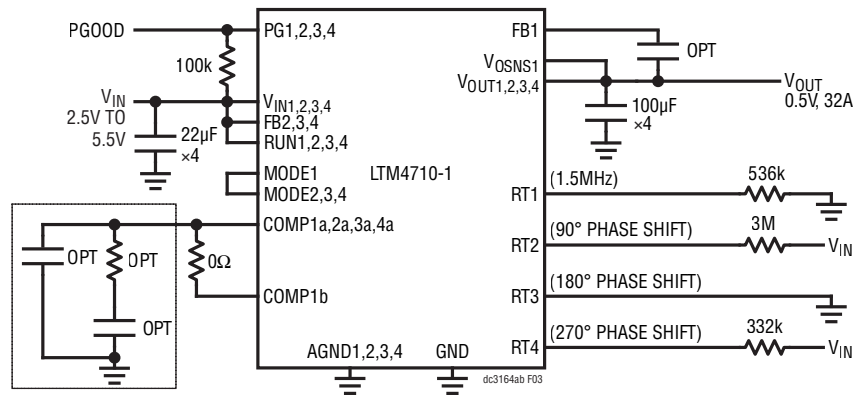
## MULTIPHASE CONFIGURATION

For output loads that demand more than 8A of current, multiple LTM4710-1 channels can be paralleled to run out of phase to provide more output current without increasing input and output voltage ripples. Figure 3 shows the typical paralleled application where channel 1 is used as the main channel and the rest of LTM4710-1 channels are programmed as the subordinate channels to achieve the same switching frequency, interleaved phase shift and current sharing among different channels.

The RT pin of the main phase is connected to a resistor to AGND, programming the frequency and configuring

the MODE pin to become clock output used to drive the MODE pin of the subordinate phase(s).

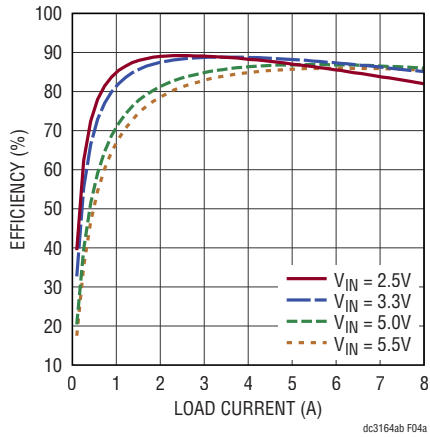
Connecting the FB pin to  $V_{IN}$  configures a phase as a subordinate phase. The MODE becomes an input, and the voltage control loop is disabled. The subordinate phase current control loop is still active, and the peak current is controlled via the shared COMP node. The phase shift of a subordinate phase relative to the main phase is programmed with a resistor divider on the RT pin. Refer to the LTM4710-1 data sheet for more detailed information.



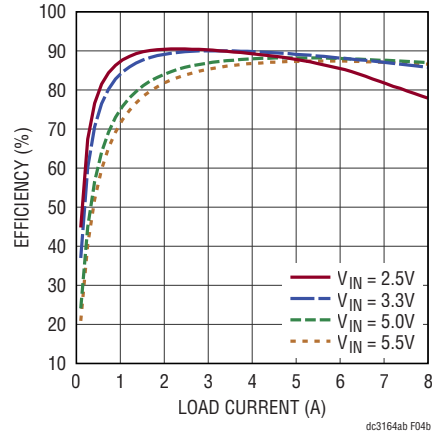
PINS NOT SHOWN IN THIS CIRCUIT: SSTT, SW; COMP2b, COMP3b, COMP4b NO CONNECTION.

**Figure 3. Paralleled Single Output, 0.5V, 32A DC/DC  $\mu$ Module Regulator**

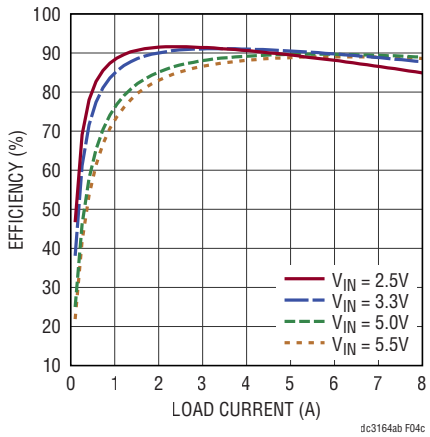
**TYPICAL PERFORMANCE CHARACTERISTICS**



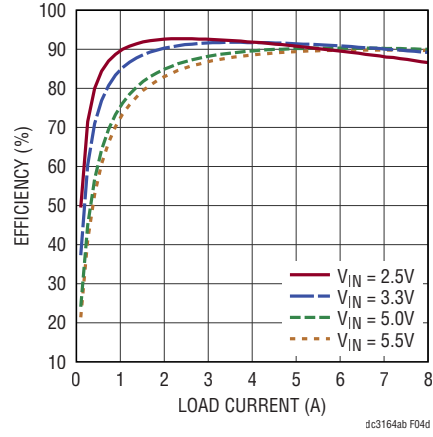
**(a)  $V_{OUT1} = 0.8V$**



**(b)  $V_{OUT2} = 1.0V$**

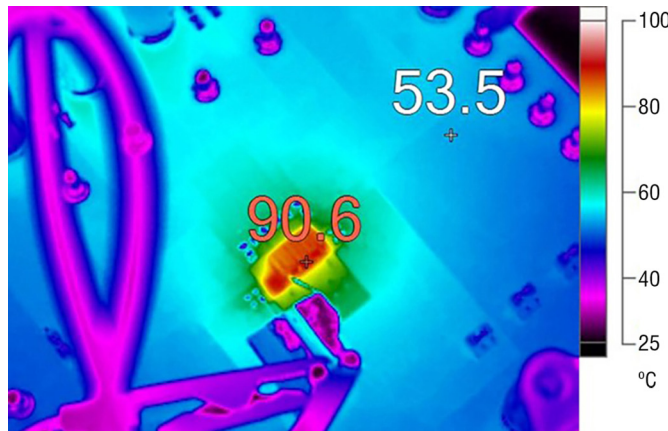


**(c)  $V_{OUT3} = 1.2V$**



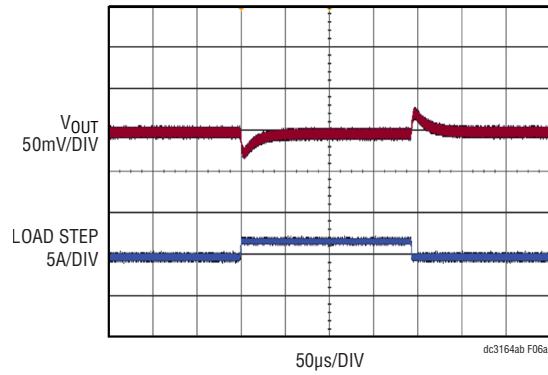
**(d)  $V_{OUT4} = 1.5V$**

**Figure 4. Measured Efficiency of Each Channel ( $f_{SW} = 1.5MHz$ ), No Forced Air Cooling with  $T_A = 25^\circ C$**

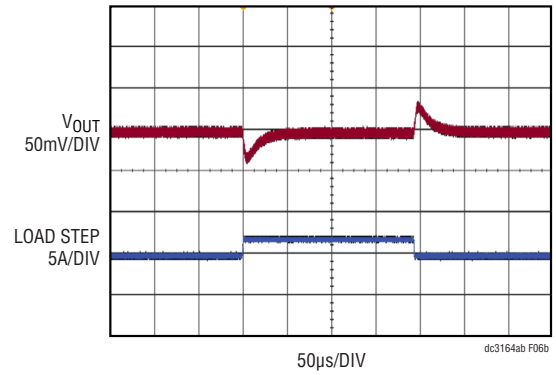


**Figure 5. Thermal Performance of 0.8V, 1.0V, 1.2V, and 1.5V with 8A per Output ( $V_{IN} = 3.3V$ ,  $f_{SW} = 1.5MHz$ ),  $T_A = 25^\circ C$ , No Forced Air Cooling**

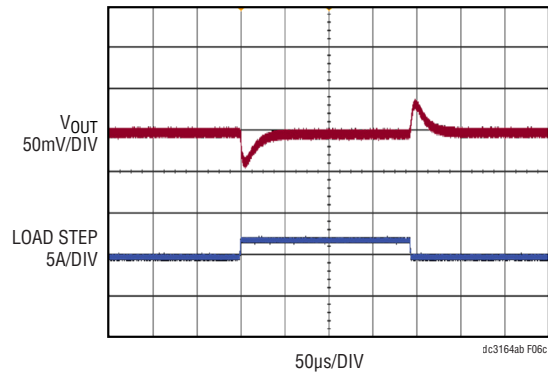
## TYPICAL PERFORMANCE CHARACTERISTICS



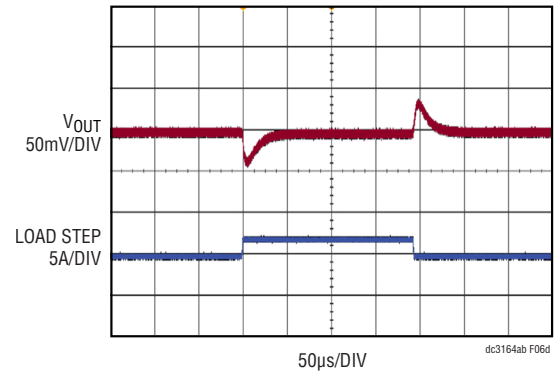
(a)  $V_{OUT1} = 0.8V$



(b)  $V_{OUT2} = 1.0V$



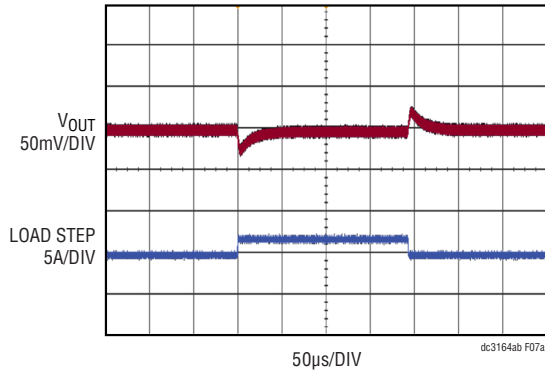
(c)  $V_{OUT3} = 1.2V$



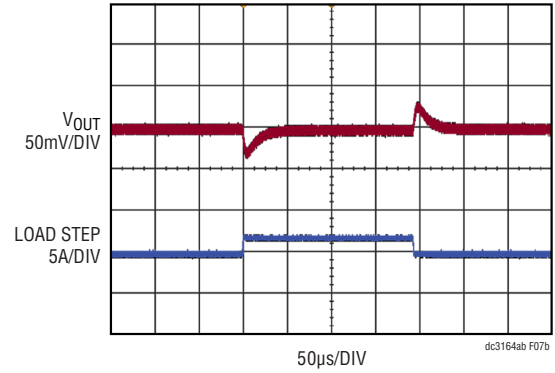
(d)  $V_{OUT4} = 1.5V$

Figure 6. Load Transient Responses with Load Steps 0A to 2A to 0A,  $di/dt = 2A/\mu s$  ( $V_{IN} = 3.3V$ ,  $f_{SW} = 1.5MHz$ )

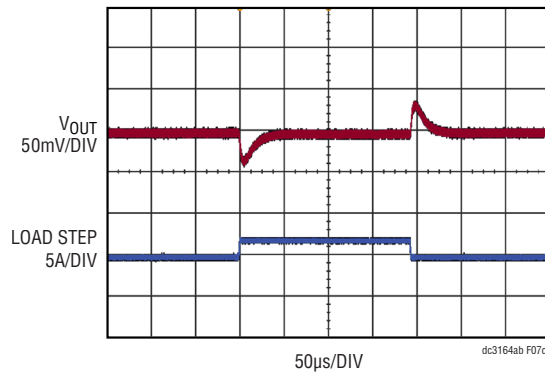
**TYPICAL PERFORMANCE CHARACTERISTICS**



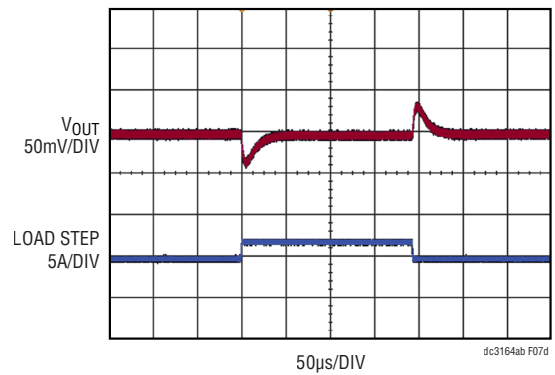
(a)  $V_{OUT1} = 0.8V$



(b)  $V_{OUT2} = 1.0V$



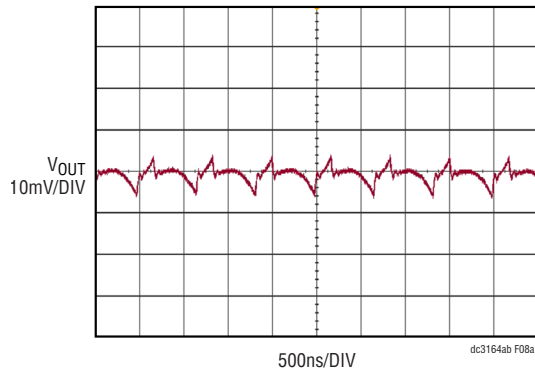
(c)  $V_{OUT3} = 1.2V$



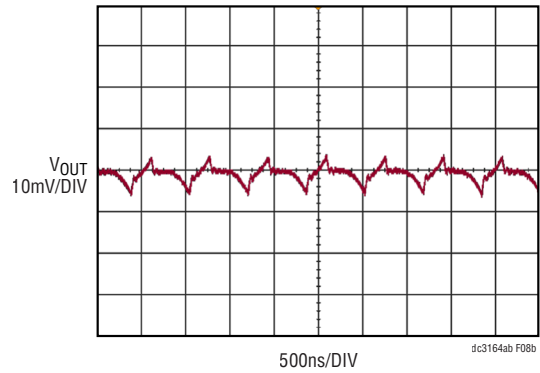
(d)  $V_{OUT4} = 1.5V$

Figure 7. Load Transient Responses with Load Steps 6A to 8A to 6A,  $di/dt = 2A/\mu s$  ( $V_{IN} = 3.3V$ ,  $f_{SW} = 1.5MHz$ )

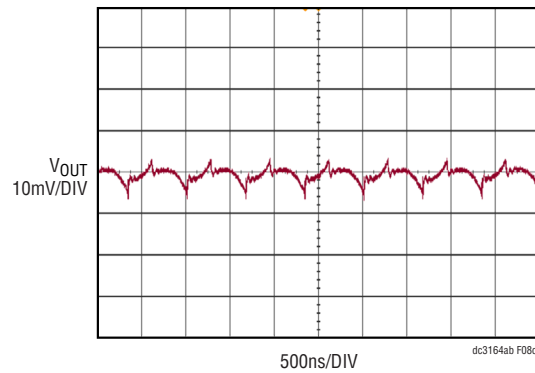
## TYPICAL PERFORMANCE CHARACTERISTICS



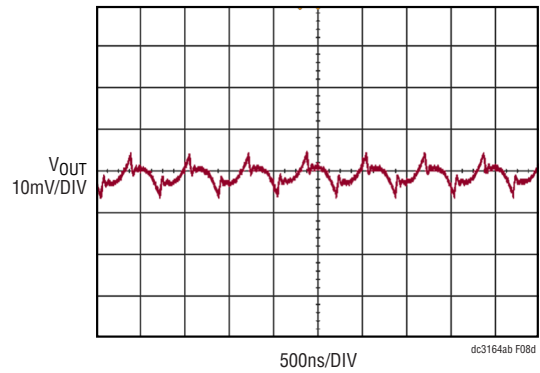
(a)  $V_{OUT1} = 0.8V$ ,  $I_{OUT1} = 8A$



(b)  $V_{OUT2} = 1.0V$ ,  $I_{OUT2} = 8A$



(c)  $V_{OUT3} = 1.2V$ ,  $I_{OUT3} = 8A$



(d)  $V_{OUT4} = 1.5V$ ,  $I_{OUT4} = 8A$

Figure 8. Output Voltage Ripple ( $V_{IN} = 3.3V$ ,  $f_{SW} = 1.5MHz$ , 350MHz BW)



## PARTS LIST

ITEM	QTY	REFERENCE	PART DESCRIPTION	MANUFACTURER/PART NUMBER
<b>Required Circuit Components</b>				
1	12	C1, C3-C5, C18-C19, C47-C49, C54, C62-C63	CAP., 22 $\mu$ F, X5R, 10V, 20%, 0603	SAMSUNG, CL10A226MP8NUNE
2	1	C2	CAP., 150 $\mu$ F, ALUM POLY, OS-CON, 10V, 20%, 8mm $\times$ 6.9mm, E7, SMD, RADIAL, SVP	PANASONIC, 10SVP150MX
3	5	C8, C25-C26, C45-C46	CAP., 0.1 $\mu$ F, X7R, 50V, 10%, 0603	TDK, C1608X7R1H104K080AA
4	4	C10, C16, C29, C35	CAP., 22 $\mu$ F, X5R, 6.3V, 20%, 0805	TDK, C2012X5R0J226M125AC
5	4	C11, C15, C30, C34	CAP., 47 $\mu$ F, X5R, 6.3V, 20%, 0603, NO SUBS. ALLOWED	MURATA, GRM188R60J476ME15D
6	4	C12, C14, C33, C38	CAP., 100 $\mu$ F, X6S, 4V, 20%, 0805	MURATA, GRM21BC80G107ME15L
7	2	C55, C56	CAP., 47 $\mu$ F, X5R, 10V, 20%, 0805	TDK, C2012X5R1A476M125AC
8	4	CFFW1, CFFW2, CFFW3, CFFW4	CAP., 68pF, C0G, 25V, 10%, 0603	KEMET, C0603C680K3GACTU
9	15	R1-R2, R7-R8, R14-R16, R72, R78-R81, R85, R88, R90	RES., 0 $\Omega$ , 1/10W, 0603, AEC-Q200	PANASONIC, ERJ3GEY0R00V
10	1	R3	RES., 16.5k, 1%, 1/10W, 0603, AEC-Q200	VISHAY, CRCW060316K5FKEA
11	8	R27, R29-R31, R68, R69-R71	RES., 10k, 5%, 1/10W, 0603	YAGEO, RC0603JR-0710KL
12	4	R60-R63	RES., 10 $\Omega$ , 1%, 1/10W, 0603	YAGEO, RC0603FR-0710RL
13	4	RBT2, RTP2, RTP3, RTP4	RES., 10k, 1%, 1/10W, 0603	YAGEO, RC0603FR-0710KL
14	1	RBT3	RES., 7.15k, 1%, 1/10W, 0603, AEC-Q200	PANASONIC, ERJ3EKF7151V
15	1	RBT4	RES., 4.99k, 1%, 1/10W, 0603, AEC-Q200	PANASONIC, ERJ3EKF4991V
16	1	RSET1	RES., 24.9k, 1%, 1/10W, 0603, AEC-Q200	PANASONIC, ERJ3EKF2492V
17	1	RT1	RES., 536k, 1%, 1/10W, 0603, AEC-Q200	PANASONIC, ERJ3EKF5363V
18	1	L1	IND., 98 $\Omega$ AT100MHz, FERRITE BEAD, 25%, 18A, 0.9m $\Omega$ , 1LN, 7847	WURTH ELEKTRONIK, 7427932
19	1	U1	IC, LOW $V_{IN}$ QUAD 8A Silent Switcher $\mu$ Module, BGA	ANALOG DEVICES, LTM4710EV-1#PBF
20	1	U2	IC, MULTIPHASE OSC WITH FREQ MOD, MSOP-10	ANALOG DEVICES, LTC6902CMS#PBF
<b>Additional Demo Board Circuit Components</b>				
1	0	C9, C17, C28, C36	CAP., OPTION, 1206	
2	0	C50-C53, C57-C60	CAP., OPTION, 1210	
3	0	C61	CAP., OPTION, 0805	
4	0	CITH1-CITH4, CITHP1-CITHP4	CAP., OPTION, 0603	
5	0	R9-R10, R13, R17-R18, R32-R35, R37-R40, R42- R45, R65-R66, R77, R82-R83, R91-R94, RITH1-RITH4, RMOD1, RT2-RT4	RES., OPTION, 0603	
6	0	R36, R41, R46	RES., OPTION, 2512	
7	0	R95-R98	RES., OPTION, 2010	

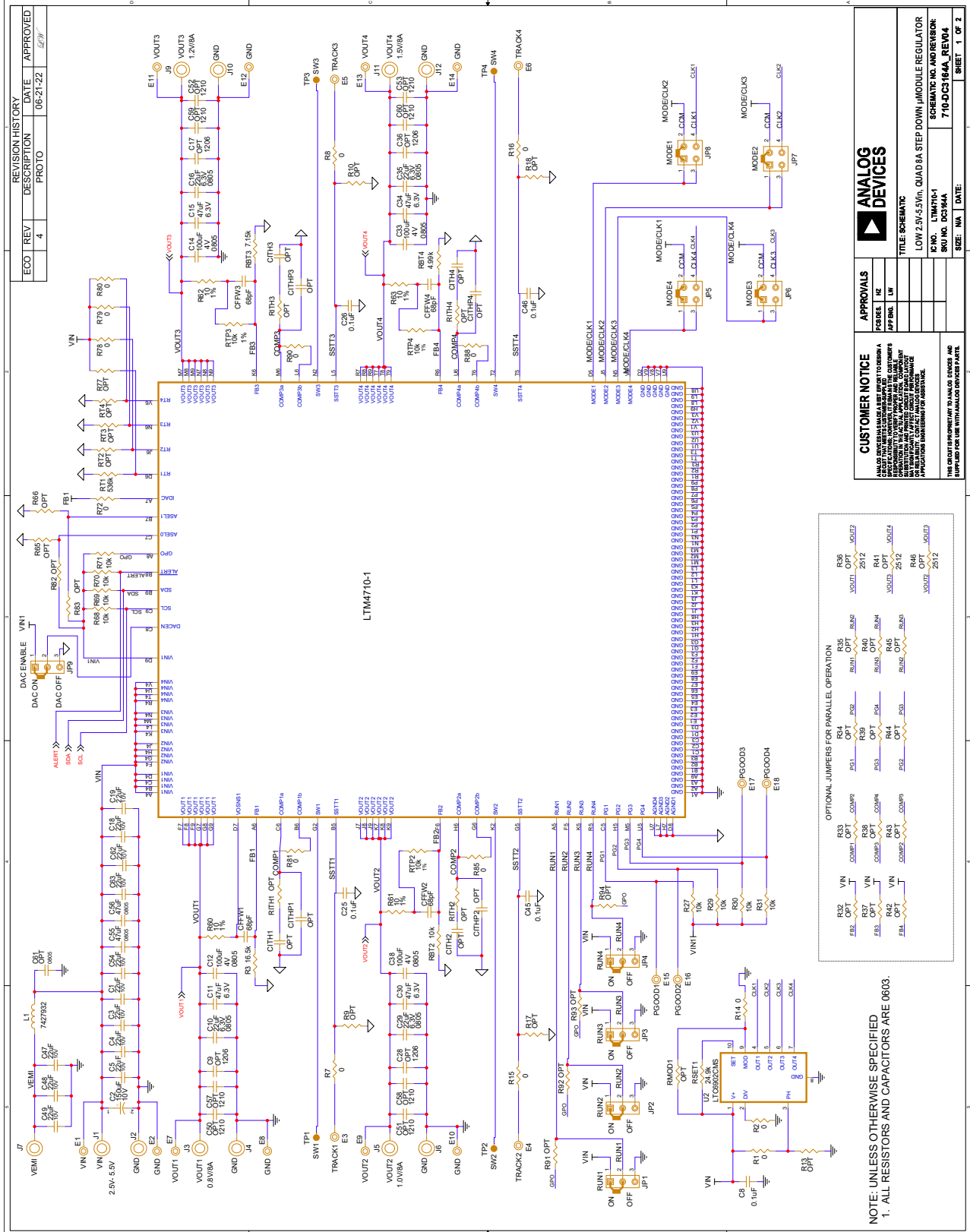
# DEMO MANUAL DC3164A-B

---

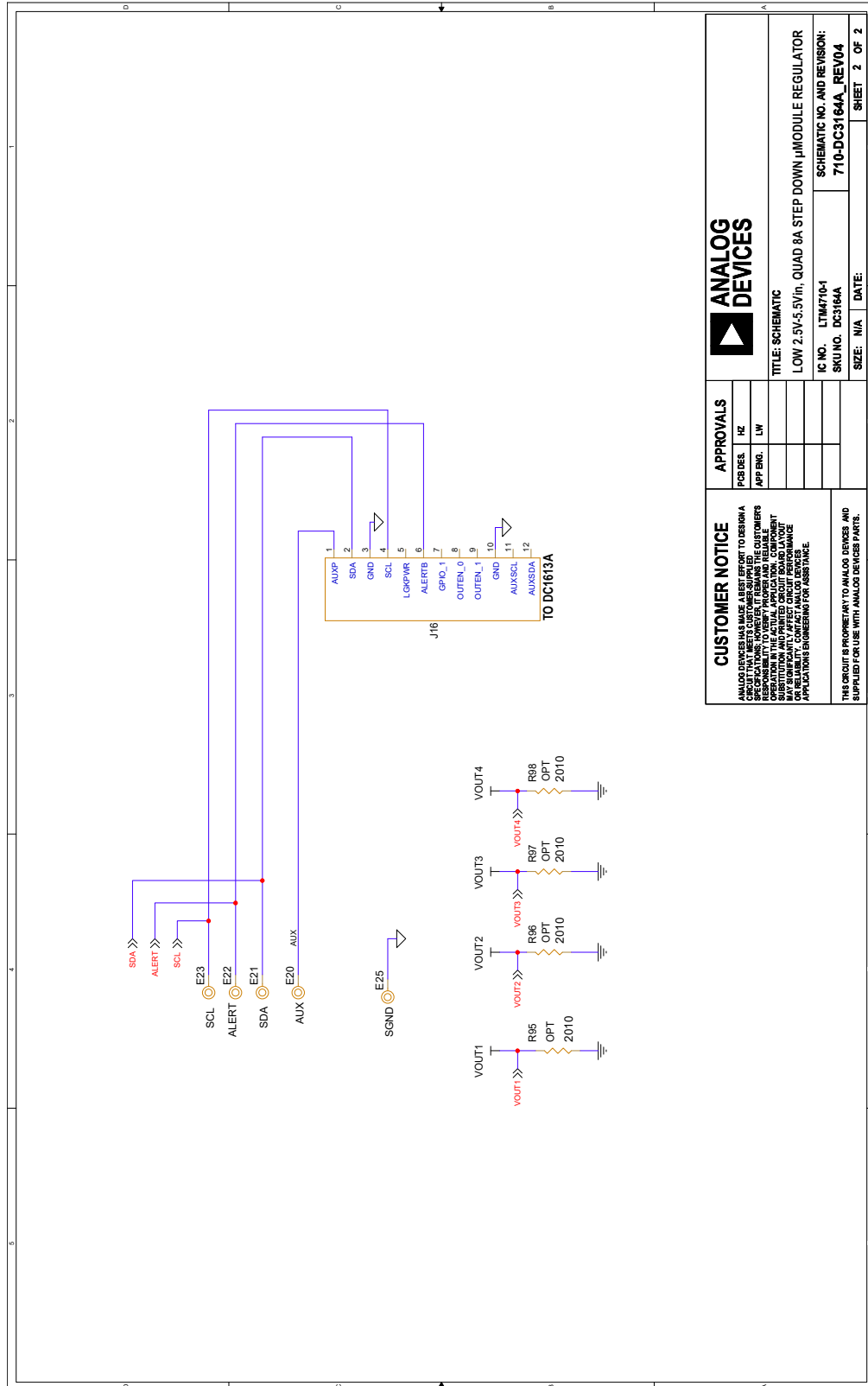
## PARTS LIST

ITEM	QTY	REFERENCE	PART DESCRIPTION	MANUFACTURER/PART NUMBER
<b>Hardware for Demo Board Only</b>				
1	23	E1-E18, E20-E23, E25	TEST POINT, TURRET, 0.094" MTG. HOLE, PCB 0.062" THK	MILL-MAX, 2501-2-00-80-00-00-07-0
2	11	J1-J7, J9-J12	CONN., BANANA JACK, FEMALE, THT, NON-INSULATED, SWAGE, 0.218"	KEYSTONE, 575-4
3	1	J16	CONN., HDR, SHROUDED, MALE, 2x6, 2mm, VERT, ST, THT	AMPHENOL, 98414-G06-12ULF
4	5	JP1-JP4, JP9	CONN., HDR, MALE, 1x3, 2mm, VERT, ST, THT, NO SUBS. ALLOWED	WURTH ELEKTRONIK, 62000311121
5	4	JP5-JP8	CONN., HDR, MALE, 2x2, 2mm, VERT, ST, THT, 10 $\mu$ Au	SAMTEC, TMM-102-02-L-D
6	4	MP1-MP4	STANDOFF, NYLON, SNAP-ON, 0.25" (6.4mm)	KEYSTONE, 8831
7	1	PCB1	PCB, DC3164A	ANALOG DEVICES APPROVED SUPPLIER, 600-DC3164A
8	9	XJP1-XJP9	CONN., SHUNT, FEMALE, 2-POS, 2mm	WURTH ELEKTRONIK, 60800213421

SCHEMATIC DIAGRAM



## SCHEMATIC DIAGRAM



		APPROVALS	
		PCB DES. / HW	APP. ENG. / LW
<b>CUSTOMER NOTICE</b> ANALOG DEVICES HAS MADE A BEST EFFORT TO DESIGN A SPECIFIC BOARD, HOWEVER, IT REMAINS THE CUSTOMER'S RESPONSIBILITY TO VERIFY THE BOARD DESIGN, COMPONENT SUBSTITUTION, AND PRINTED CIRCUIT BOARD LAYOUT AGAINST THE ACTUAL APPLICATION COMPONENT OR RELIABILITY. CONTACT ANALOG DEVICES APPLICATIONS ENGINEERING FOR ASSISTANCE.			
<b>TITLE: SCHEMATIC</b> LOW 2.5V-5.5V/in, QUAD 8A STEP DOWN $\mu$ MODULE REGULATOR		IC NO. LTM710-1 SKU NO. DC3164A SIZE: N/A DATE:	
SCHEMATIC NO. AND REVISION: 710-DC3164A_REV04		SHEET 2 OF 2	

## REVISION HISTORY

REV	DATE	DESCRIPTION	PAGE NUMBER
0	07/23	Initial Release.	—