

Multi-Footprint Single Op Amp Prototyping Boards

DESCRIPTION

The DC417B demo board set gives maximum flexibility for prototyping single op amp circuits. This demo manual lists which components to use for common op amp circuits and an example is given for a standard pinout single op amp circuit.

Design files for this circuit board are available at <http://www.linear.com/demo>

LT, LT, LTC, LTM, Linear Technology and the Linear logo are registered trademarks of Linear Technology Corporation. All other trademarks are the property of their respective owners.

OPERATING PRINCIPLES

The DC417B demo board comes as a two board set; one board for DIP8, S8, DFN8, and MS8 packages and the other board for SOT23-5 and SOT23-6 packages. Each board is laid out such that most of the general op amp circuits can be easily built. Both boards have decoupling cap positions included.

Component positions are included for common circuit configurations. Take your schematic and identify component positions on the board which correspond to the components in the schematic. Air-wire other components as needed, taking advantage of the exposed ground planes

as desired. Terminal posts at the sides of both boards give easy access to power, ground, inputs, and outputs. Access is provided to all IC pins. Pins 1, 5, and 8 are brought out to terminals for easy access on the DIP8, S8, DFN8, and MS8 board. Pin 5 is brought out to a terminal on the SOT23-5 and SOT23-6 board. These pins are typically used for offset adjustment, trimming VOS, or shutdown. The layout includes positions for BNC connectors for both inputs and outputs. Although component pads are marked as C for capacitors and R for resistors, any component that fits any footprint can be placed on the board.

CIRCUIT EXAMPLE

To build a noninverting amp using the DIP8/S8/MS8/DFN8 board use the R3 component position for the feedback resistor and R11 for the gain set resistor. C6 and C2 are the decoupling caps located close to the IC package and C3 and C5 the bulk decoupling caps located next to the power input terminals at the edge of the board. Jumper wires or 0Ω resistors would be used for the R8 component position on the input path to use the BNC connector J3, or R8 and R13 to use input terminal TP11 and at R7 on the output path to use BNC J2 or output terminal TP9 for connection input and output signals.

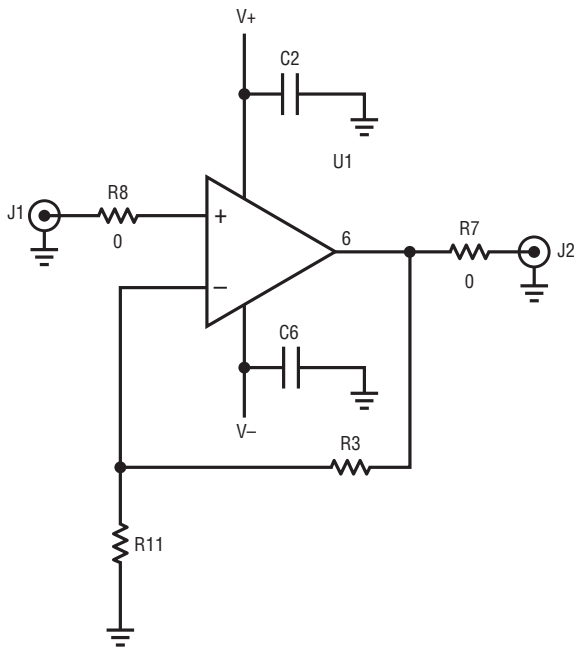
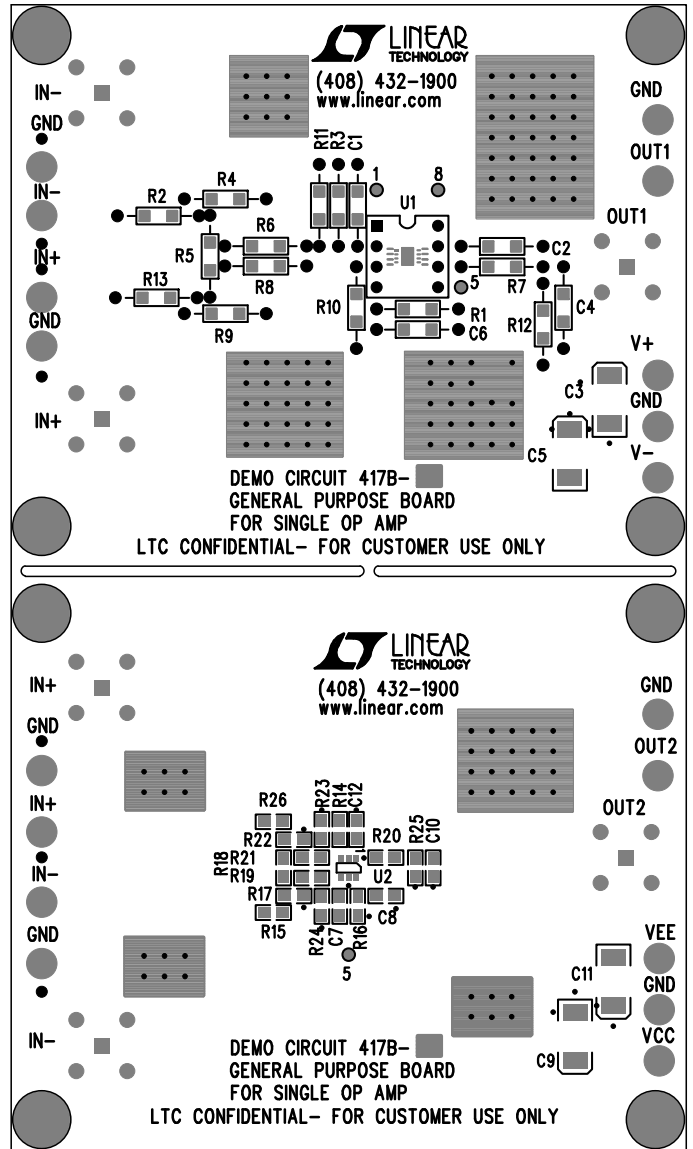
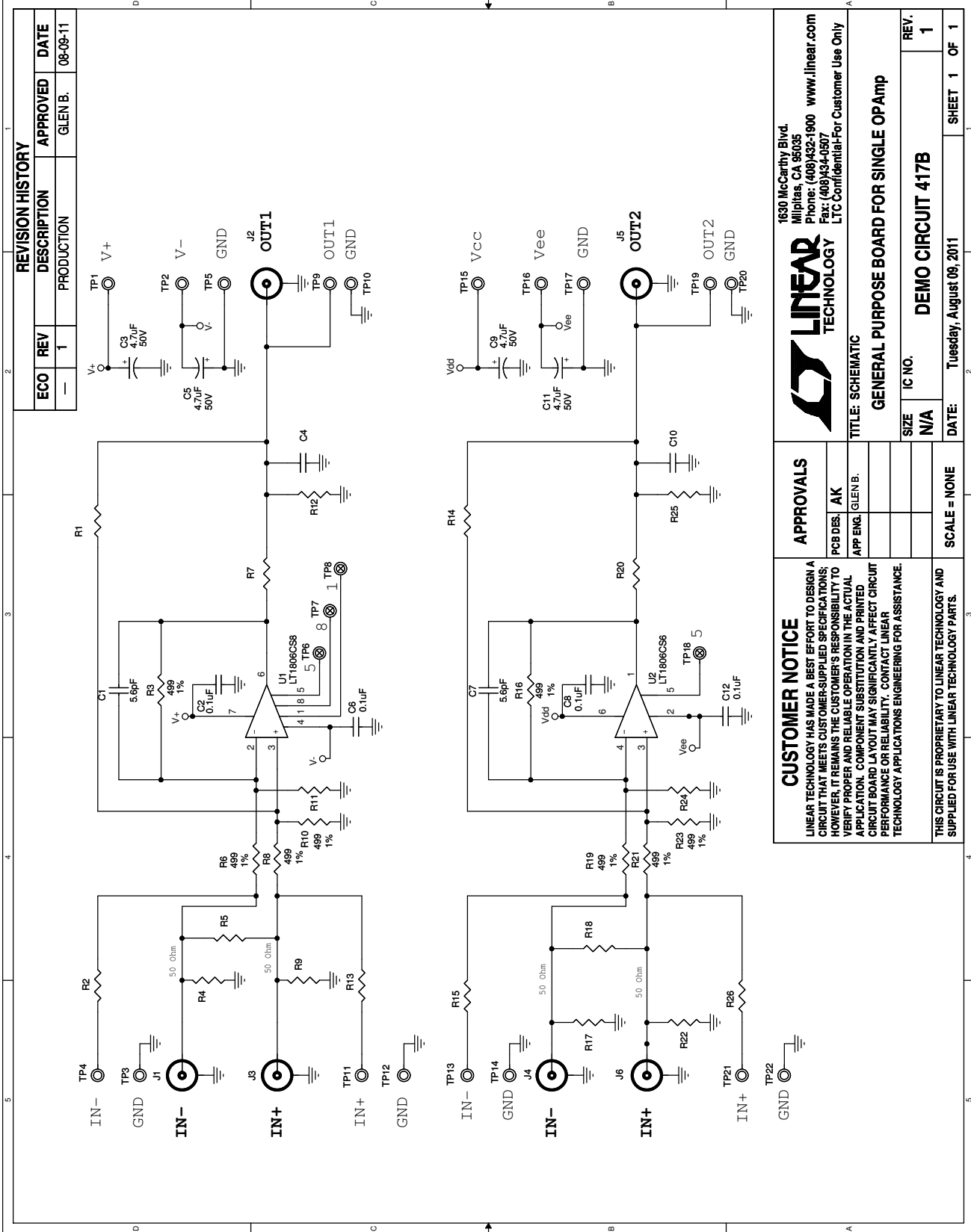

Figure 1. Example Circuit



SCHEMATIC DIAGRAM



REVISION HISTORY				
ECO	REV	DESCRIPTION	APPROVED	DATE
—	1	PRODUCTION	GLEN B.	08-09-11

LINEAR TECHNOLOGY
 1630 McCarthy Blvd.
 Milpitas, CA 95035
 Phone: (408)432-1900 www.linear.com
 Fax: (408)434-0507
 LTC Confidential-For Customer Use Only

TITLE: SCHEMATIC
GENERAL PURPOSE BOARD FOR SINGLE OP AMP

SIZE	IC NO.	REV.
N/A	DEMO CIRCUIT 417B	1
DATE:	Tuesday, August 09, 2011	SHEET 1 OF 1

CUSTOMER NOTICE
 LINEAR TECHNOLOGY HAS MADE A BEST EFFORT TO DESIGN A CIRCUIT THAT MEETS CUSTOMER-SUPPLIED SPECIFICATIONS. HOWEVER, IT REMAINS THE CUSTOMER'S RESPONSIBILITY TO VERIFY PROPER AND RELIABLE OPERATION IN THE ACTUAL APPLICATION. COMPONENT SUBSTITUTION AND PRINTED CIRCUIT BOARD LAYOUT MAY SIGNIFICANTLY AFFECT CIRCUIT PERFORMANCE OR RELIABILITY. CONTACT LINEAR TECHNOLOGY APPLICATIONS ENGINEERING FOR ASSISTANCE.

APPROVALS

PCB DES.	AK
APP ENG.	GLEN B.

SCALE = NONE

THIS CIRCUIT IS PROPRIETARY TO LINEAR TECHNOLOGY AND SUPPLIED FOR USE WITH LINEAR TECHNOLOGY PARTS.



Information furnished by Linear Technology Corporation is believed to be accurate and reliable. However, no responsibility is assumed for its use. Linear Technology Corporation makes no representation that the interconnection of its circuits as described herein will not infringe on existing patent rights.