

# IEEE 802.3af PD Power over Ethernet Interface Controller with Dual Current Limit

## FEATURES

- Complete Power Interface Port for IEEE 802<sup>®</sup>.3af Powered Devices (PDs)
- Onboard 100V, 400mA Power MOSFET
- Precision Dual Level Current Limit
- Onboard 25k Signature Resistor with Disable
- Programmable Classification Current (Class 0-4)
- Undervoltage Lockout
- Thermal Overload Protection
- Power Good Signal
- Available in 8-Pin SO and Low Profile (3mm × 3mm) DFN Packages

## APPLICATIONS

- IP Phone Power Management
- Wireless Access Points
- Telecom Power Control

## DESCRIPTION

The LTC<sup>®</sup>4257-1 provides complete signature and power interface functions for a device operating in an IEEE 802.3af Power over Ethernet (PoE) system. The LTC4257-1 simplifies Powered Device (PD) design by incorporating the 25k signature resistor, classification current source, input current limit, undervoltage lockout, thermal overload protection, signature disable and power good signaling, all in a single 8-pin package. The LTC4257-1 includes a precision, dual level current limit circuit. This allows it to charge large load capacitors and interface with legacy Power over Ethernet systems while maintaining compatibility with the current IEEE 802.3af specification. By incorporating a high voltage power MOSFET onboard, the LTC4257-1 provides the system designer with reduced cost while also saving board space.

The LTC4257-1 can interface directly with a variety of Linear Technology DC/DC converter products to provide a cost effective power solution for IP phones, wireless access points and other PDs. Linear Technology also provides network power controllers for Power Sourcing Equipment (PSE) applications.

The LTC4257-1 is available in the 8-pin SO and low profile (3mm × 3mm) DFN packages.

LT, LTC and LT are registered trademarks of Linear Technology Corporation. All other trademarks are the property of their respective owners.

## TYPICAL APPLICATION

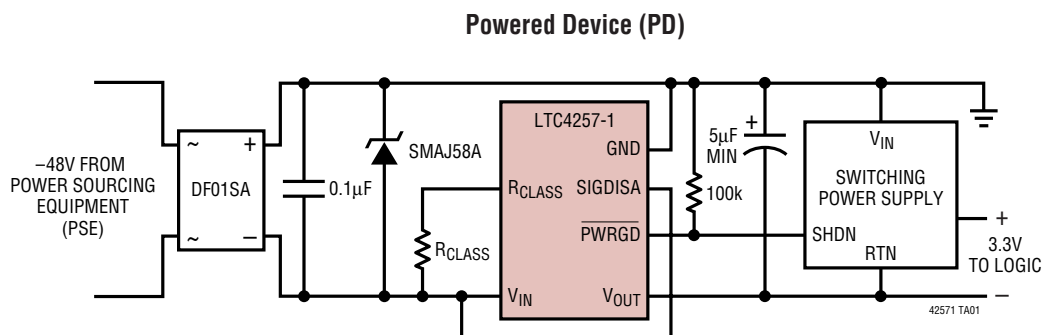

# LTC4257-1

## ABSOLUTE MAXIMUM RATINGS

(Notes 1, 2)

$V_{IN}$ Voltage	0.3V to -100V
$V_{OUT}$ , SIGDISA, PWRGD Voltage	$V_{IN} + 100V$ to $V_{IN} - 0.3V$
$R_{CLASS}$ Voltage	$V_{IN} + 7V$ to $V_{IN} - 0.3V$
PWRGD Current	10mA
$R_{CLASS}$ Current	100mA

Operating Ambient Temperature Range	
LTC4257C-1	0°C to 70°C
LTC4257I-1	-40°C to 85°C
Storage Temperature Range	
S8 Package	-65°C to 150°C
DD Package	-65°C to 125°C
Lead Temperature (Soldering, 10 sec)	
	300°C

## PACKAGE/ORDER INFORMATION

<p>S8 PACKAGE 8-LEAD PLASTIC SO <math>T_{JMAX} = 150^{\circ}C</math>, <math>\theta_{JA} = 150^{\circ}C/W</math></p>		<p>DD PACKAGE 8-LEAD (3mm x 3mm) PLASTIC DFN <math>T_{JMAX} = 125^{\circ}C</math>, <math>\theta_{JA} = 43^{\circ}C/W</math> EXPOSED PAD TO BE SOLDERED TO ELECTRICALLY ISOLATED PCB HEATSINK</p>	
ORDER PART NUMBER	S8 PART MARKING	ORDER PART NUMBER	DD PART MARKING*
LTC4257CS8-1	42571	LTC4257CDD-1	LBFZ
LTC4257IS8-1	425711	LTC4257IDD-1	
<b>Order Options</b> Tape and Reel: Add #TR Lead Free: Add #PBF Lead Free Tape and Reel: Add #TRPBF Lead Free Part Marking: <a href="http://www.linear.com/leadfree/">http://www.linear.com/leadfree/</a>			

Consult LTC Marketing for parts specified with wider operating temperature ranges. \*The temperature grades are identified by a label on the shipping container.

## ELECTRICAL CHARACTERISTICS

The ● denotes the specifications which apply over the full operating temperature range, otherwise specifications are at  $T_A = 25^{\circ}C$ . (Note 3)

SYMBOL	PARAMETER	CONDITIONS	MIN	TYP	MAX	UNITS	
$V_{IN}$	Supply Voltage	Voltage with Respect to GND Pin (Notes 4, 5, 6)					
	Maximum Operating Voltage		●		-57	V	
	Signature Range		●	-1.5	-9.5	V	
	Classification Range		●	-12.5	-21	V	
	UVLO Turn-On Voltage		●	-34.8	-36.0	-37.2	V
	UVLO Turn-Off Voltage		●	-29.3	-30.5	-31.5	V
$I_{IN\_ON}$	IC Supply Current when ON	$V_{IN} = -48V$ , Pins 5, 6, 7 Floating	●		3	mA	
$I_{IN\_CLASS}$	IC Supply Current During Classification	$V_{IN} = -17.5V$ , Pins 2, 7 Floating, $V_{OUT}$ Tied to GND (Note 7)	●	0.35	0.50	0.65	mA
$\Delta I_{CLASS}$	Current Accuracy During Classification	$10mA < I_{CLASS} < 40mA$ , $-12.5V \leq V_{IN} \leq -21V$ , (Notes 8, 9)	●		$\pm 3.5$	%	
$R_{SIGNATURE}$	Signature Resistance	$-1.5V \leq V_{IN} \leq -9.5V$ , $V_{OUT}$ Tied to GND, IEEE 802.3af 2-Point Measurement (Notes 4, 5)	●	23.25	26.00	k $\Omega$	
$R_{INVALID}$	Invalid Signature Resistance	$-1.5V \leq V_{IN} \leq -9.5V$ , SIGDISA and $V_{OUT}$ Tied to GND, IEEE 802.3af 2-Point Measurement (Notes 4, 5)	●	9	11.8	k $\Omega$	

42571fb

## ELECTRICAL CHARACTERISTICS

The ● denotes the specifications which apply over the full operating temperature range, otherwise specifications are at  $T_A = 25^\circ\text{C}$ . (Note 3)

SYMBOL	PARAMETER	CONDITIONS	MIN	TYP	MAX	UNITS	
$V_{IH}$	Signature Disable High Level Input Voltage	With Respect to $V_{IN}$ , High Level Invalidates Signature (Note 10)	● 3		57	V	
$V_{IL}$	Signature Disable Low Level Input Voltage	With Respect to $V_{IN}$ , Low Level Enables Signature	●		0.45	V	
$R_{INPUT}$	Signature Disable Input Resistance	With Respect to $V_{IN}$	● 100			k $\Omega$	
$V_{PG\_OUT}$	Power Good Output Low Voltage	$I = 1\text{mA}$ , $V_{IN} = -48\text{V}$ , $\overline{\text{PWRGD}}$ Referenced to $V_{IN}$	●		0.5	V	
$V_{PG\_THRES\_FALL}$	Power Good Trip Point	$V_{IN} = -48\text{V}$ , Voltage Between $V_{IN}$ and $V_{OUT}$ (Note 9)	●	1.3	1.5	1.7	V
$V_{PG\_THRES\_RISE}$		$V_{OUT}$ Falling $V_{OUT}$ Rising	●	2.7	3.0	3.3	V
$I_{PG\_LEAK}$	Power Good Leakage	$V_{IN} = 0\text{V}$ , $\overline{\text{PWRGD}}$ FET Off, $V_{\overline{\text{PWRGD}}} = 57\text{V}$	●		1	$\mu\text{A}$	
$R_{ON}$	On-Resistance	$I = 350\text{mA}$ , $V_{IN} = -48\text{V}$ , Measured from $V_{IN}$ to $V_{OUT}$ (Note 9)	●	1.0	1.6	$\Omega$	
					2.0	$\Omega$	
$I_{OUT\_LEAK}$	$V_{OUT}$ Leakage	$V_{IN} = 0\text{V}$ , Power MOSFET Off, $V_{OUT} = 57\text{V}$ (Note 11)	●		150	$\mu\text{A}$	
$I_{LIMIT\_HIGH}$	Input Current Limit, High Level	$V_{IN} = -48\text{V}$ , $V_{OUT} = -43\text{V}$ (Notes 12, 13) $0^\circ\text{C} \leq T_A \leq 70^\circ\text{C}$ $-40^\circ\text{C} \leq T_A \leq 85^\circ\text{C}$	●	350	375	400	mA
			●	340	375	400	mA
$I_{LIMIT\_LOW}$	Input Current Limit, Low Level	$V_{IN} = -48\text{V}$ , $V_{OUT} = -43\text{V}$ (Notes 12, 13)	●	100	140	180	mA
$T_{SHUTDOWN}$	Thermal Shutdown Trip Temperature	(Notes 12, 14)		140		$^\circ\text{C}$	

**Note 1:** Stresses beyond those listed under Absolute Maximum Ratings may cause permanent damage to the device. Exposure to any Absolute Maximum Rating condition for extended periods may affect device reliability and lifetime.

**Note 2:** All voltages are with respect to GND pin unless otherwise noted.

**Note 3:** The LTC4257-1 operates with a negative supply voltage in the range of  $-1.5\text{V}$  to  $-57\text{V}$ . To avoid confusion, voltages in this data sheet are always referred to in terms of absolute magnitude. Terms such as “maximum negative voltage” refer to the largest negative voltage and a “rising negative voltage” refers to a voltage that is becoming more negative.

**Note 4:** The LTC4257-1 is designed to work with two polarity protection diode drops between the PSE and PD. Parameter ranges specified in the Electrical Characteristics are with respect to LTC4257-1 pins and are designed to meet IEEE 802.3af specifications when these diode drops are included. See Applications Information.

**Note 5:** Signature resistance is measured via the 2-point  $\Delta V/\Delta I$  method as defined by IEEE 802.3af. The LTC4257-1 signature resistance is offset from 25k to account for diode resistance. With two series diodes, the total PD resistance will be between 23.75k $\Omega$  and 26.25k $\Omega$  and meet IEEE 802.3af specifications. The minimum probe voltages measured at the LTC4257-1 pins are  $-1.5\text{V}$  and  $-2.5\text{V}$ . The maximum probe voltages are  $-8.5\text{V}$  and  $-9.5\text{V}$ .

**Note 6:** The LTC4257-1 includes hysteresis in the UVLO voltages to preclude any start-up oscillation. Per IEEE 802.3af requirements, the LTC4257-1 will power up from a voltage source with 20 $\Omega$  series resistance on the first trial.

**Note 7:**  $I_{IN\_CLASS}$  does not include classification current programmed at Pin 2. Total supply current in classification mode will be  $I_{IN\_CLASS} + I_{CLASS}$  (see Note 8).

**Note 8:**  $I_{CLASS}$  is the measured current flowing through  $R_{CLASS}$ .  $\Delta I_{CLASS}$  accuracy is with respect to the ideal current defined as  $I_{CLASS} = 1.237/R_{CLASS}$ . The current accuracy specification does not include variations in  $R_{CLASS}$  resistance. The total classification current for a PD also includes the IC quiescent current ( $I_{IN\_CLASS}$ ). See Applications Information.

**Note 9:** For the DD package, this parameter is assured by design and wafer level testing.

**Note 10:** To disable the 25k signature, tie SIGDISA to GND ( $\pm 0.1\text{V}$ ) or hold SIGDISA high with respect to  $V_{IN}$ . See Applications Information.

**Note 11:**  $I_{OUT\_LEAK}$  includes current drawn at the  $V_{OUT}$  pin by the power good status circuit. This current is compensated for in the 25k $\Omega$  signature resistance and does not affect PD operation.

**Note 12:** The LTC4257-1 includes thermal protection. In the event of an overtemperature condition, the LTC4257-1 will turn off the power MOSFET until the part cools below the overtemperature limit. The LTC4257-1 is also protected against thermal damage from incorrect classification probing by the PSE. If the LTC4257-1 exceeds the overtemperature trip point, the classification load current is disabled.

**Note 13:** The LTC4257-1 includes dual level input current limit. At turn-on, before C1 is charged, the LTC4257-1 current level is set to the low level. After C1 is charged and the  $V_{OUT} - V_{IN}$  voltage difference is below the power good threshold, the LTC4257-1 switches to high level current limit. The LTC4257-1 stays in high level current limit until the input voltage drops below the UVLO turn-off threshold.

**Note 14:** This IC includes overtemperature protection that is intended to protect the device during momentary overload conditions. Junction temperature will exceed  $125^\circ\text{C}$  when overtemperature protection is active. Continuous operation above the specified maximum operating junction temperature may impair device reliability.

## TYPICAL PERFORMANCE CHARACTERISTICS

**Input Current vs Input Voltage**  
25k Detection Range

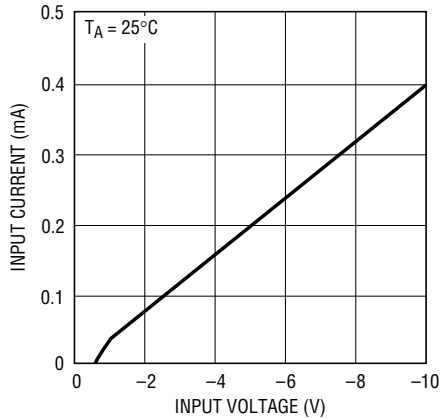

4357 G01

**Input Current vs Input Voltage**

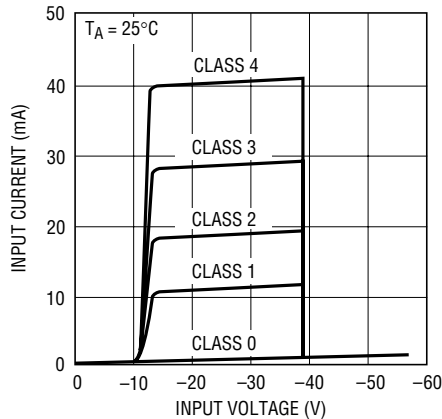

42571 G02

**Input Current vs Input Voltage**

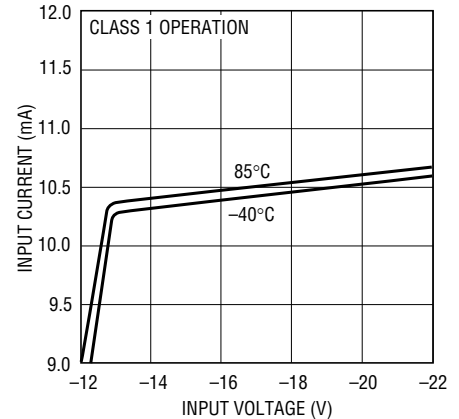

42571 G03

**Input Current vs Input Voltage**

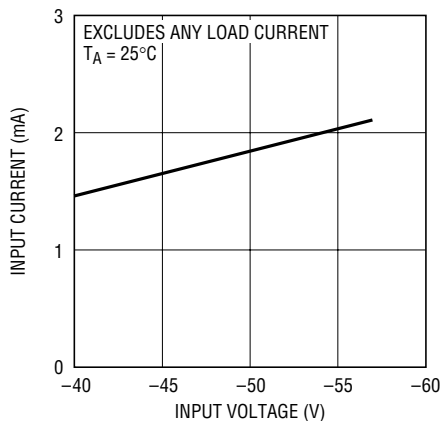

42571 G04

**Signature Resistance vs Input Voltage**

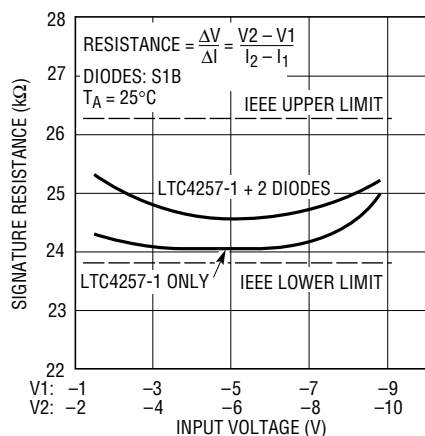

42571 G05

**Normalized UVLO Threshold vs Temperature**

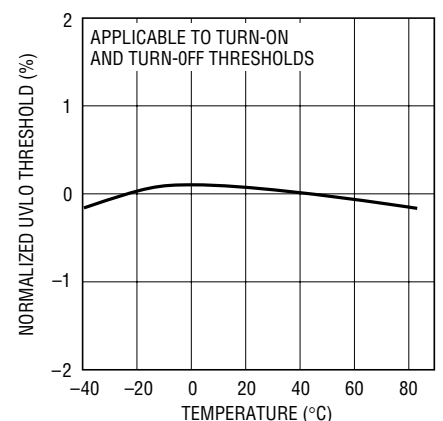

42571 G06

**Power Good Output Low Voltage vs Current**

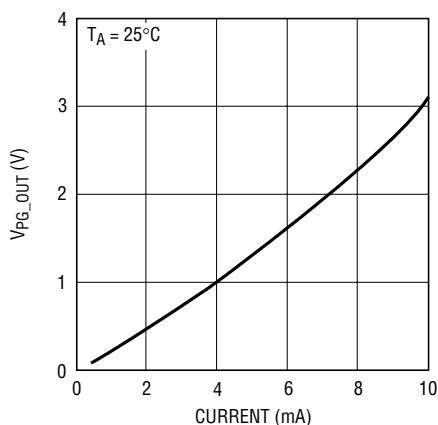

42571 G07

**V<sub>OUT</sub> Leakage Current**

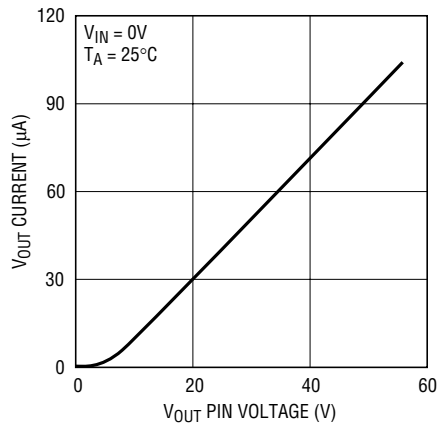

42571 G08

**Current Limit vs Input Voltage**

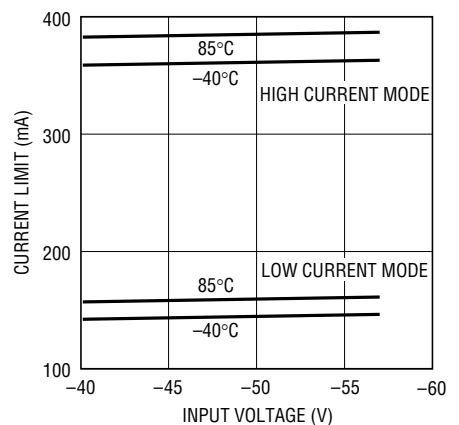

42571 G09

## PIN FUNCTIONS

**NC (Pin 1):** No Internal Connection.

**R<sub>CLASS</sub> (Pin 2):** Class Select Input. Used to set the current value the LTC4257-1 maintains during classification. Connect a resistor between R<sub>CLASS</sub> and V<sub>IN</sub> (see Table 2).

**NC (Pin 3):** No Internal Connection.

**V<sub>IN</sub> (Pin 4):** Power Input. Tie to system –48V through the input diode bridge.

**V<sub>OUT</sub> (Pin 5):** Power Output. Supplies –48V to the PD load through an internal power MOSFET that limits input current. V<sub>OUT</sub> is high impedance until the input voltage rises above the turn-on UVLO threshold. The output is then current limited. See Applications Information.

**PWRGD (Pin 6):** Power Good Output, Open-Drain. Signals to the PD load that the LTC4257-1 MOSFET is on and that the PD's DC/DC converter can start operation. Low impedance indicates power is good. PWRGD is high impedance during detection, classification and in the event of a thermal overload. PWRGD is referenced to V<sub>IN</sub>.

**SIGDISA (Pin 7):** Signature Disable Input. Allows the PD to command the LTC4257-1 to present an invalid signature resistance and to remain inactive. Connecting SIGDISA to GND lowers the signature resistance to an invalid value and disables all functions of the LTC4257-1. If left floating, SIGDISA is internally pulled to V<sub>IN</sub>. If unused, tie SIGDISA to V<sub>IN</sub>.

**GND (Pin 8):** Ground. Tied to system ground and power return through the input diode bridge.

## BLOCK DIAGRAM

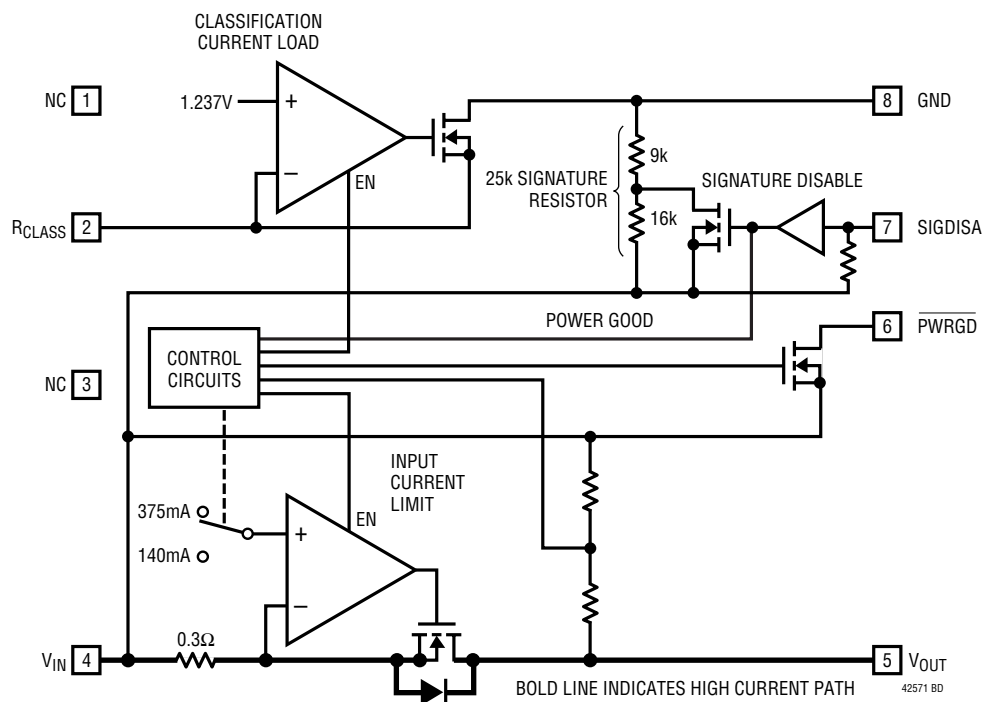

## APPLICATIONS INFORMATION

The LTC4257-1 is intended for use as the front end of a Powered Device (PD) adhering to the IEEE 802.3af standard. The LTC4257-1 includes a trimmed 25k signature resistor, classification current source, and an input current limit circuit. With these functions integrated into the LTC4257-1, the signature and power interface for a PD that meets all the requirements of the IEEE 802.3af specification can be built with a minimum of external components.

The LTC4257-1 has been specifically designed to interface with legacy PoE PSEs which do not meet the inrush current requirement of the IEEE 802.3af specification. By setting the initial inrush current limit to a low level, a PD using the LTC4257-1 minimizes the current drawn from the PSE during start-up. After powering up, the LTC4257-1 switches to the high level current limit, thereby allowing the PD to consume up to 12.95 watts if an 802.3af PSE is present. This low level current limit also allows the LTC4257-1 to charge arbitrarily large load capacitors without exceeding the inrush limits of the IEEE 802.3af specification. This dual level current limit provides the system designer with flexibility to design PDs which are compatible with legacy PSEs while also being able to take advantage of the higher power allocation available in an IEEE 802.3af system.

Using an LTC4257-1 for the power and signature interface functions of a PD provides several advantages. The LTC4257-1 current limit circuit includes an onboard, 100V, 400mA power MOSFET with low leakage. This onboard low leakage MOSFET avoids the possibility of corrupting the 25k signature resistor while also saving board space and cost. In addition, the inrush current limit requirement of the IEEE 802.3af standard causes large transient power dissipation in the PD. The LTC4257-1 is designed to allow multiple turn-on sequences without overheating the miniature 8-lead package. In the event of excessive power cycling, the LTC4257-1 provides thermal overload protection to keep the onboard power MOSFET within its safe operating area.

### Operation

The LTC4257-1 has several modes of operation depending on the applied input voltage as shown in Figure 1 and

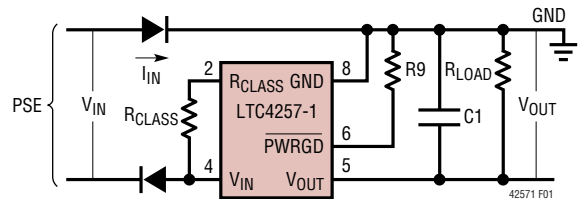
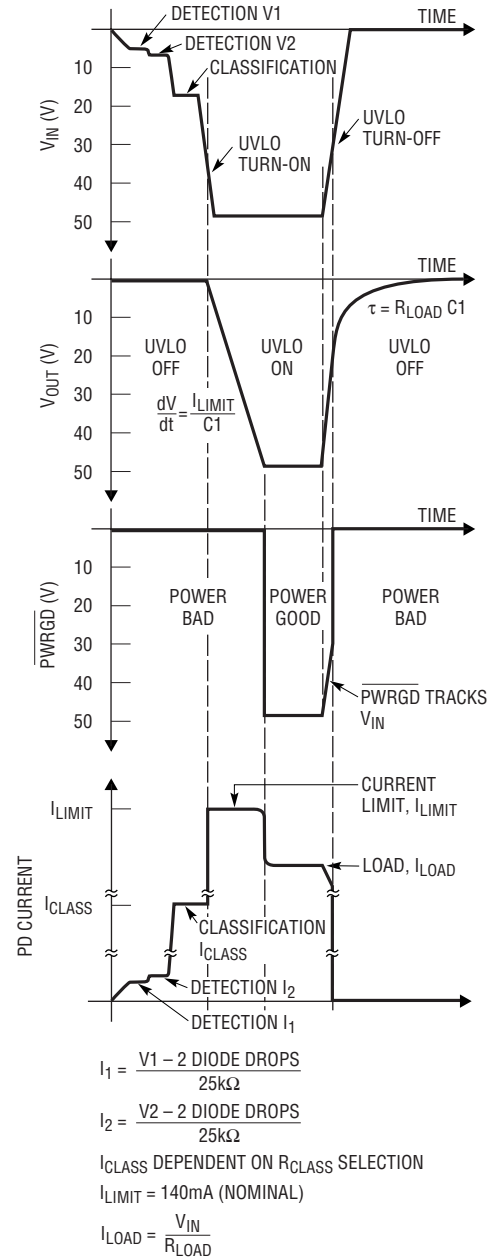

Figure 1. Output Voltage,  $\overline{\text{PWRGD}}$  and PD Current as a Function of Input Voltage

## APPLICATIONS INFORMATION

summarized in Table 1. These various modes satisfy the requirements defined in the IEEE 802.3af specification. The input voltage is applied to the  $V_{IN}$  pin and is with reference to the GND pin. This input voltage is always negative. To avoid confusion, voltages in this data sheet are always referred to in terms of absolute magnitude. Terms such as *maximum negative voltage* refer to the largest negative voltage and a *rising negative voltage* refers to a voltage that is becoming more negative. References to electrical parameters in this applications section use the nominal value. Refer to the Electrical Characteristics section for the range of values a particular parameter will have.

**Table 1. LTC4257-1 Operational Mode as a Function of Input Voltage**

INPUT VOLTAGE ( $V_{IN}$ with RESPECT to GND)	LTC4257-1 MODE OF OPERATION
0V to $-1.4V$	Inactive
$-1.5V$ to $-10V$	25k Signature Resistor Detection
$-11V$ to $-12.4V$	Classification Load Current Ramps up from 0% to 100%
$-12.5V$ to UVLO*	Classification Load Current Active
UVLO* to $-57V$	Power Applied to PD Load

\*UVLO includes hysteresis.  
Rising input threshold  $\cong -36.0V$   
Falling input threshold  $\cong -30.5V$

### Series Diodes

The IEEE 802.3af defined operating modes for a PD reference the input voltage at the RJ45 connector on the PD. However, PD circuitry must include diode bridges between the RJ45 connector and the LTC4257-1 (Figure 2). The LTC4257-1 takes this into account by compensating for these diode drops in the threshold points for each range of operation. Since the voltage ranges specified in the LTC4257-1 electrical specifications are with respect to the IC pins, for both the signature and classification ranges, the LTC4257-1 lower end extends two diode drops below the IEEE 802.3af specification. A similar adjustment is made for the UVLO voltages.

### Detection

During detection, the PSE will apply a voltage in the range of  $-2.8V$  to  $-10V$  on the cable and look for a 25k signature resistor. This identifies the device at the end of the cable as a PD. With the terminal voltage in this range, the LTC4257-1 connects an internal 25k resistor between GND and the  $V_{IN}$  pins. This precision, temperature compensated resistor presents the proper characteristics to alert the Power Sourcing Equipment (PSE) at the other end of the cable that a PD is present and desires power to be applied.

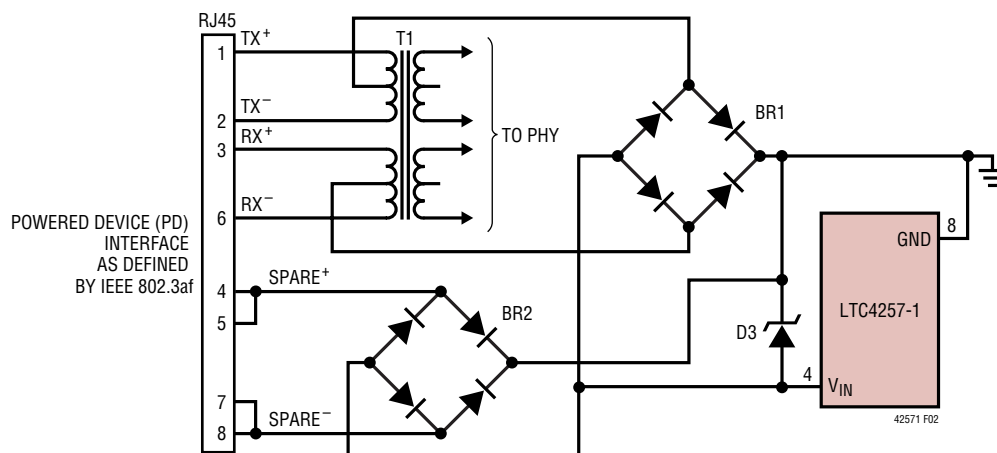

**Figure 2. PD Front End Using Diode Bridges On Main and Spare Inputs**

## APPLICATIONS INFORMATION

The power applied to a PD is allowed to use either of two polarities and the PD must be able to accept this power so it is common to install a diode bridge on the input. The LTC4257-1 is designed to compensate for the voltage and resistance effects of these two series diodes. The signature range extends below the IEEE range to accommodate the voltage drop of the diodes. The IEEE specification requires the PSE to use a  $\Delta V/\Delta I$  measurement technique to keep the DC offset of these diodes from affecting the signature resistance measurement. However, the diode resistance appears in series with the signature resistor and must be included in the overall signature resistance of the PD. The LTC4257-1 compensates for the two series diodes in the signature path by offsetting the resistance so that a PD built using the LTC4257-1 will meet the IEEE specification.

In some applications it is necessary to control whether or not the PD is detected. In this case, the 25k signature can be enabled and disabled with the use of the SIGDISA pin (Figure 3). Disabling the signature via the SIGDISA pin will change the signature resistor to 9k which is an invalid signature per the IEEE 802.3af specification. This invalid signature is present for PD input voltages from  $-2.8V$  to  $-10V$ . If the input rises above  $-10V$ , the signature resistor reverts to 25k to minimize power dissipation in the LTC4257-1. To disable the signature, tie SIGDISA to GND. Alternately, the SIGDISA pin can be driven high with respect to  $V_{IN}$ . When SIGDISA is high, all functions of the LTC4257-1 are disabled.

### Classification

Once the PSE has detected a PD, the PSE may optionally classify the PD. Classification provides a method for more efficient allocation of power by allowing the PSE to identify lower-power PDs and allocate less power for these devices. The IEEE 802.3af specification defines five classes (Table 2) with varying power levels. The designer selects the appropriate classification based on the power consumption of the PD. For each class, there is an associated load current that the PD asserts onto the line during classification probing. The PSE measures the PD load current to determine the proper classification and PD power requirements.

**Table 2. Summary of IEEE 802.3af Power Classifications and LTC4257-1  $R_{CLASS}$  Resistor Selection**

CLASS	USAGE	MAXIMUM POWER LEVELS AT INPUT OF PD (W)	NOMINAL CLASSIFICATION LOAD CURRENT (mA)	LTC4257-1 $R_{CLASS}$ RESISTOR ( $\Omega$ , 1%)
0	Default	0.44 to 12.95	<5	Open
1	Optional	0.44 to 3.84	10.5	124
2	Optional	3.84 to 6.49	18.5	68.1
3	Optional	6.49 to 12.95	28	45.3
4	Reserved	Reserved*	40	30.9

\*Class 4 is currently reserved and should not be used.

Early revisions of the IEEE 802.3af draft specification defined two methods that a PSE could use in order to perform PD classification. These methods are known as Measured Current and Measured Voltage. The IEEE has since removed the Measured Voltage method from the

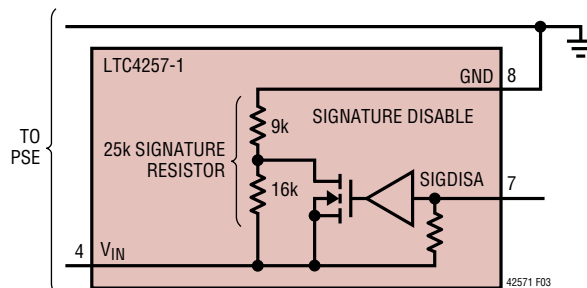

**Figure 3. 25k Signature Resistor with Disable**



## APPLICATIONS INFORMATION

specification. The LTC4257-1 is compatible with the IEEE 802.3af standard and also works with the obsolete Measured Voltage method.

In the Measured Current method (Figure 4), the PSE presents a fixed voltage between  $-15.5\text{V}$  and  $-20.5\text{V}$  to the PD. With the input voltage in this range, the LTC4257-1 asserts a load current from the GND pin through the  $R_{\text{CLASS}}$  resistor. The magnitude of the load current is set with the selection of the  $R_{\text{CLASS}}$  resistor. The resistor value associated with each class is shown in Table 2.

In the Measured Voltage method (Figure 5), the PSE drives a current into the PD and monitors the voltage across the PD terminals. The PSE current steps between classification load current values in order to classify the PD under test. For PSE probe currents below the PD load current, the

LTC4257-1 will keep the PD terminal voltage below the classification voltage range. For PSE probe currents above the PD load current, the LTC4257-1 will force the PD terminal voltage above the classification voltage range.

During classification, a moderate amount of power is dissipated in the LTC4257-1. The IEEE 802.3af specification limits the classification time to 75ms. The LTC4257-1 is designed to handle the power dissipation for this time period. If the PSE probing exceeds 75ms, the LTC4257-1 may overheat. In this situation, the thermal protection circuit will engage and disable the classification current source in order to protect the part. The LTC4257-1 stays in classification mode until the input voltage rises above the UVLO turn-on voltage.

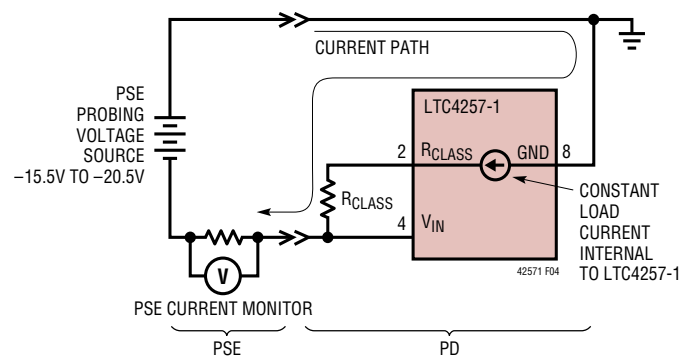

**Figure 4. IEEE 802.3af Measured-Current Method of Classification Probing**

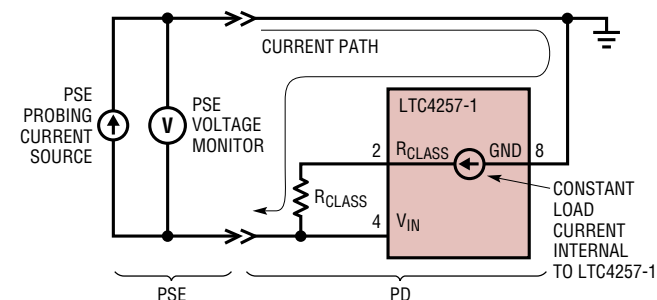

IF PSE PROBING CURRENT < LTC4257-1 LOAD CURRENT, PD TERMINAL VOLTAGE IS < 15V  
IF PSE PROBING CURRENT > LTC4257-1 LOAD CURRENT, PD TERMINAL VOLTAGE IS > 20V  
42571 F05

**Figure 5. IEEE 802.af Measured-Voltage Method of Classification Probing**

## APPLICATIONS INFORMATION

### Undervoltage Lockout

The IEEE specification dictates a maximum turn-on voltage of 42V and a minimum turn-off voltage of 30V for the PD. In addition, the PD must maintain large on-off hysteresis to prevent resistive losses in the wiring between the PSE and the PD from causing start-up oscillation. The LTC4257-1 incorporates an undervoltage lockout (UVLO) circuit that monitors line voltage to determine when to apply power to the PD load (Figure 6). Before power is applied to the load, the  $V_{OUT}$  pin is high impedance and sitting at ground potential since there is no charge on capacitor C1. When the input voltage rises above the UVLO turn-on threshold, the LTC4257-1 removes the classification load current and turns on the internal power MOSFET. C1 charges up under LTC4257-1 current limit control and the  $V_{OUT}$  pin transitions from 0V to  $V_{IN}$ . This sequence is shown in Figure 1. The LTC4257-1 includes a hysteretic UVLO circuit that keeps power applied to the load until the input voltage falls below the UVLO turn-off threshold.

Once the input voltage drops below  $-30V$ , the internal power MOSFET is turned off and the classification load current is re-enabled. C1 will discharge through the PD circuitry and the  $V_{OUT}$  pin will go to a high impedance state.

### Input Current Limit

IEEE 802.3af specifies a maximum inrush current and also specifies a minimum load capacitor between the GND and  $V_{OUT}$  pins. To control turn-on surge current in the system, the LTC4257-1 integrates a dual level current limit circuit with an onboard power MOSFET and sense resistor to provide a complete inrush control circuit without additional external components. At turn on, the LTC4257-1 will limit input current to the low level, allowing the load capacitor to ramp up to the line voltage in a controlled manner.

The LTC4257-1 has been specifically designed to interface with legacy PSEs which do not meet the inrush current requirement of the IEEE 802.3af specification. This is

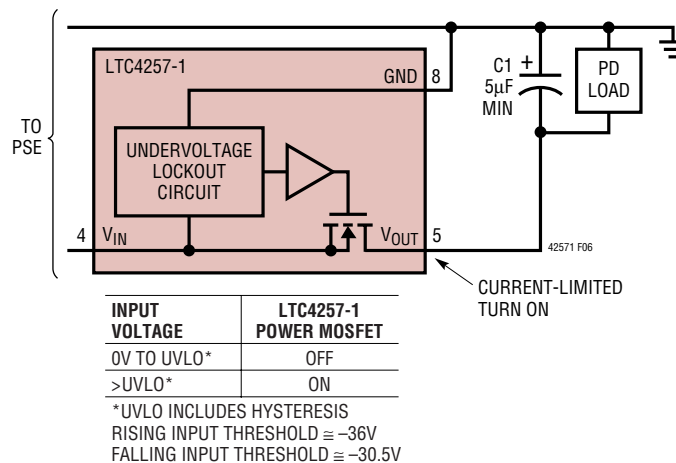

Figure 6. LTC4257-1 Undervoltage Lockout

## APPLICATIONS INFORMATION

accomplished by a dual level current limit. At turn on before C1 is charged, the LTC4257-1 current limit is set to the low level. After C1 is charged up and the  $V_{OUT} - V_{IN}$  voltage difference is below the power good threshold, the LTC4257-1 switches to the high level current limit. The dual level current limit allows legacy PSEs with limited current sourcing capability to power up the PD while also allowing the PD to draw full power from an IEEE 802.3af PSE.

The dual level current limit also allows use of arbitrarily large load capacitors. The IEEE 802.3af specification mandates that at turn on the PD not exceed the inrush current limit for more than 50ms. The LTC4257-1 is not restricted by the 50ms time limit because the load capacitor is charged with a current below the IEEE inrush current limit specification. Therefore, it is possible to use larger load capacitors with the LTC4257-1.

As the LTC4257-1 switches from the low to the high level current limit, a momentary increase in current can be observed. This current spike is a result of the LTC4257-1 charging the last 1.5V at the high level current limit. When charging a 10 $\mu$ F capacitor, the current spike is typically 100 $\mu$ s wide and 125% of the nominal low level current limit.

The LTC4257-1 stays in the high level current limit mode until the input voltage drops below the UVLO turn-off

threshold. This dual level current limit provides the system designer with the flexibility to design PDs which are compatible with legacy PSEs while also being able to take advantage of the higher power allocation available in an IEEE 802.3af system.

During the current limited turn on, a large amount of power is dissipated in the power MOSFET. The LTC4257-1 is designed to accept this thermal load and is thermally protected to avoid damage to the onboard power MOSFET. Note that in order to adhere to the IEEE 802.3af standard, it is necessary for the PD designer to ensure the PD steady-state power consumption falls within the limits shown in Table 2.

### Power Good

The LTC4257-1 includes a power good circuit (Figure 7) that is used to indicate to the PD circuitry that load capacitor C1 is fully charged and that the PD can start DC/DC converter operation. The power good circuit monitors the voltage across the internal power MOSFET and  $\overline{\text{PWRGD}}$  is asserted when the voltage drops below 1.5V. The power good circuit includes a large amount of hysteresis to allow the LTC4257-1 to operate near the current limit point without inadvertently disabling  $\overline{\text{PWRGD}}$ . The MOSFET voltage must increase to 3V before  $\overline{\text{PWRGD}}$  is disabled.

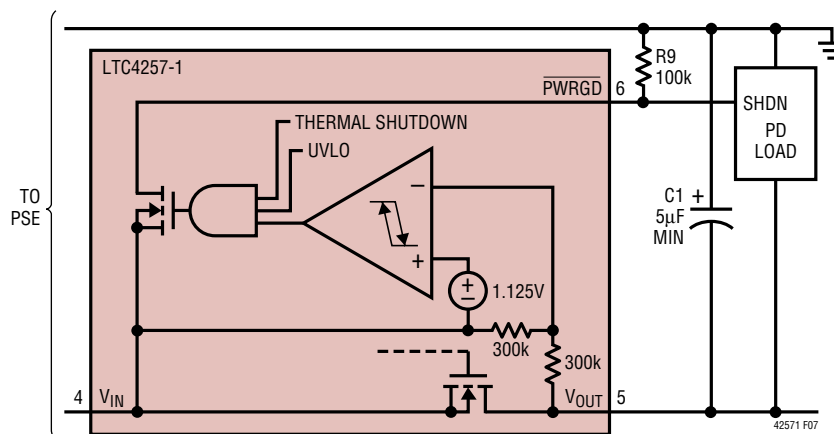

Figure 7. LTC4257-1 Power Good

## APPLICATIONS INFORMATION

If a sudden increase in voltage appears on the input line, this voltage step will be transferred through capacitor C1 and appear across the power MOSFET. The response of the LTC4257-1 will depend on the magnitude of the voltage step, the rise time of the step, the value of capacitor C1 and the DC load. For fast rising inputs, the LTC4257-1 will attempt to quickly charge capacitor C1 using an internal secondary current limit circuit. In this scenario, the PSE current limit should provide the overall limit for the circuit. For slower rising inputs, the 375mA current limit in the LTC4257-1 will set the charge rate of capacitor C1. In either case, the  $\overline{\text{PWRGD}}$  signal may go inactive briefly while the capacitor is charged up to the new line voltage. In the design of a PD, it is necessary to determine if a step in the input voltage will cause the  $\overline{\text{PWRGD}}$  signal to go inactive and how to respond to this event. In some designs, the charge on C1 is sufficient to power the PD through this event. In this case, it may be desirable to filter the  $\overline{\text{PWRGD}}$  signal so that intermittent power bad conditions are ignored. Figure 10 demonstrates methods to insert a lowpass filter on the power good interface.

For PD designs that use a large load capacitor and also consume a lot of power, it is important to delay activation of the PD circuitry with the  $\overline{\text{PWRGD}}$  signal. If the PD circuitry is not disabled during the current-limited turn-on sequence, the PD circuitry will rob current intended for charging up the load capacitor and create a slow rising input, possibly causing the LTC4257-1 to go into thermal shutdown.

The  $\overline{\text{PWRGD}}$  pin connects to an internal open-drain, 100V transistor capable of sinking 1mA. Low impedance indicates power is good.  $\overline{\text{PWRGD}}$  is high impedance during signature and classification probing and in the event of a thermal overload.

During turn-off,  $\overline{\text{PWRGD}}$  is deactivated when the input voltage drops below 30V. In addition,  $\overline{\text{PWRGD}}$  may go active briefly at turn-on for fast rising input waveforms.  $\overline{\text{PWRGD}}$  is referenced to the  $V_{\text{IN}}$  pin and when active will be near the  $V_{\text{IN}}$  potential. The PD DC/DC converter will typically be referenced to  $V_{\text{OUT}}$  and care must be taken to ensure that the difference in potential of the  $\overline{\text{PWRGD}}$  signal does not cause any detrimental effects. Use of diode clamp D6, as shown in Figure 10, will alleviate any problems.

### Thermal Protection

The LTC4257-1 includes thermal overload protection in order to provide full device functionality in a miniature package while maintaining safe operating temperatures. Several factors create the possibility for tremendous power dissipation within the LTC4257-1. At turn on, before the load capacitor has charged up, the instantaneous power dissipated by the LTC4257-1 can be 10W. As the load capacitor charges up, the power dissipation in the LTC4257-1 will decrease until it reaches a steady-state value dependent on the DC load current. The size of the load capacitor determines how fast the power dissipation in the LTC4257-1 will subside. At room temperature, the LTC4257-1 can handle load capacitors as large as 800 $\mu\text{F}$  without going into thermal shutdown. With a large load capacitor like this, the LTC4257-1 die temperature will increase by about 50°C during a single turn-on sequence. If for some reason power were removed from the part and then quickly reapplied so that the LTC4257-1 has to charge up the load capacitor again, the temperature rise would be excessive if safety precautions were not implemented.

The LTC4257-1 protects itself from thermal damage by monitoring the die temperature. If the die temperature exceeds the overtemperature trip point, the current is reduced to zero and very little power is dissipated in the part until it cools below the overtemperature set point.

Once the LTC4257-1 has charged up the load capacitor and the PD is powered and running, there will be some residual heating due to the DC load current of the PD flowing through the internal MOSFET. In some applications, the LTC4257-1 power dissipation may be significant and if dissipated in the S8 package, excessive package heating could occur. This problem can be solved with the use of the DD package which has superior thermal performance. The DD package includes an exposed pad which should be soldered to an isolated heatsink on the printed circuit board.

During classification, excessive heating of the LTC4257-1 can occur if the PSE violates the 75ms probing time limit. To protect the LTC4257-1, thermal protection circuitry will disable classification current if the die temperature exceeds

## APPLICATIONS INFORMATION

the overtemperature trip point. When the die cools down below the trip point, classification current is enabled again.

If the PD is designed to operate at a high ambient temperature and with the maximum allowable supply (57V), there will be a limit to the size load capacitor that can be charged up before the LTC4257-1 reaches the overtemperature trip point. Hitting the overtemperature trip point intermittently does not harm the LTC4257-1, but it will delay completion of capacitor charging. Capacitors up to 200 $\mu$ F can be charged without a problem.

### EXTERNAL INTERFACE AND COMPONENT SELECTION

#### Transformer

Nodes on an Ethernet network commonly interface to the outside world via an isolation transformer (Figure 8). For powered devices, the isolation transformer must include a center tap on the media (cable) side. Proper termination is required around the transformer to provide correct impedance matching and to avoid radiated and conducted emissions. Transformer vendors such as Pulse, Bel Fuse, Tyco and others (Table 3) can provide assistance with selection of an appropriate isolation transformer and proper termination methods. These vendors have transformers specifically designed for use in PD applications.

**Table 3. Power over Ethernet Transformer Vendors**

VENDOR	CONTACT INFORMATION
Pulse Engineering	12220 World Trade Drive San Diego, CA 92128 Tel: 858-674-8100 FAX: 858-674-8262 <a href="http://www.pulseeng.com/">http://www.pulseeng.com/</a>
Bel Fuse Inc.	206 Van Vorst Street Jersey City, NJ 07302 Tel: 201-432-0463 FAX: 201-432-9542 <a href="http://www.belfuse.com/">http://www.belfuse.com/</a>
Tyco Electronics	308 Constitution Drive Menlo Park, CA 94025-1164 Tel: 800-227-7040 FAX: 650-361-2508 <a href="http://www.circuitprotection.com/">http://www.circuitprotection.com/</a>

#### Diode Bridges

IEEE 802.3af allows power wiring in either of two configurations on the TX/RX wires, plus power can be applied to the PD via the spare wire pair in the RJ45 connector. The PD is required to accept power in either polarity on both the main and spare inputs; therefore, it is common to install diode bridges on both inputs in order to accommodate the different wiring configurations. Figure 8 demonstrates an implementation of these diode bridges. The specification also mandates that the leakage back through the unused bridge be less than 28 $\mu$ A when the PD is powered with 57V.

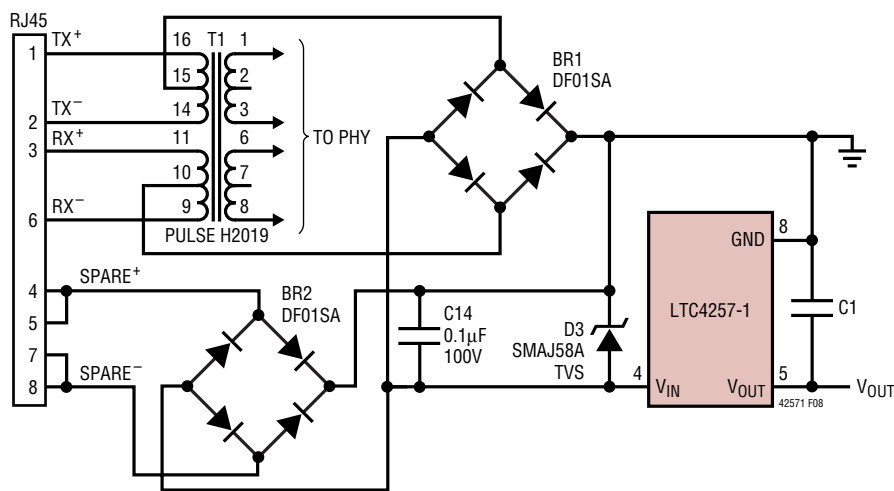

**Figure 8. PD Front End with Isolation Transformer, Diode Bridges and Capacitor**

## APPLICATIONS INFORMATION

The IEEE standard includes an AC impedance requirement in order to implement the AC disconnect function. Capacitor C14 in Figure 8 is used to meet this AC impedance requirement. A 0.1 $\mu$ F capacitor is recommended for this application.

The LTC4257-1 has several different modes of operation based on the voltage present between the  $V_{IN}$  and GND pins. The forward voltage drop of the input diodes in a PD design subtracts from the input voltage and will affect the transition point between modes. When using the LTC4257-1, it is necessary to pay close attention to this forward voltage drop. Selection of oversized diodes will help keep the PD thresholds from exceeding IEEE specifications.

The input diode bridge of a PD can consume over 4% of the available power in some applications. It may be desirable to use Schottky diodes in order to reduce this power loss. However, if the standard diode bridge is replaced with a Schottky bridge, the transition points between modes will be affected. The application circuit (Figure 11) shows a technique for using Schottky diodes while maintaining proper threshold points to meet IEEE 802.3af compliance.

### Auxiliary Power Source

In some applications, it may be desirable to power the PD from an auxiliary power source such as a wall transformer. The auxiliary power can be injected into the PD at several locations and various trade-offs exist. Power can be injected at the 3.3V or 5V output of the isolated power supply with the use of a diode ORing circuit. This method accesses the internal circuits of the PD after the isolation barrier and therefore meets the 802.3af isolation safety requirements for the wall transformer jack on the PD. Power can also be injected into the PD interface portion of the LTC4257-1. In this case, it is necessary to ensure the user cannot access the terminals of the wall transformer jack on the PD since this would compromise the 802.3af isolation safety requirements. Figure 9 demonstrates three methods of diode ORing external power into a PD. Option 1 inserts power before the LTC4257-1 while options 2 and 3 apply power after the LTC4257-1.

If power is inserted before the LTC4257-1 (option 1), it is necessary for the wall transformer to exceed the LTC4257-1 UVLO turn-on requirement and limit the maximum voltage

to 57V. This option provides input current limit for the transformer, provides a valid power good signal and simplifies power priority issues. As long as the wall transformer applies power to the PD before the PSE, it will take priority and the PSE will not power up the PD because the wall power will corrupt the 25k signature. If the PSE is already powering the PD, the wall transformer power will be in parallel with the PSE. In this case, priority will be given to the higher supply voltage. If the wall transformer voltage is higher, the PSE should remove line voltage since no current will be drawn from the PSE. On the other hand, if the wall transformer voltage is lower, the PSE will continue to supply power to the PD and the wall transformer power will not be used. Proper operation should occur in either scenario.

If auxiliary power is applied after the LTC4257-1 (option 2), a different set of tradeoffs arise. In this configuration, the wall transformer does not need to exceed the LTC4257-1 turn-on UVLO requirement; however, it is necessary to include diode D9 to prevent the transformer from applying power to the LTC4257-1. The transformer voltage requirements will be governed by the needs of the PD switcher and may exceed 57V. However, power priority issues require more intervention. If the wall transformer voltage is below the PSE voltage, then priority will be given to the PSE power. The PD will draw power from the PSE while the transformer will sit unused. This configuration is not a problem in a PoE system. On the other hand, if the wall transformer voltage is higher than the PSE voltage, the PD will draw power from the transformer. In this situation, it is necessary to address the issue of power cycling that may occur if a PSE is present. The PSE will detect the PD and apply power. If the PD is being powered by the wall transformer, then the PD will not meet the minimum load requirement and the PSE will subsequently remove power. The PSE will again detect the PD and power cycling will start. With a transformer voltage above the PSE voltage, it is necessary to either disable the signature, as shown in option 2, or install a minimum load on the output of the LTC4257-1 to prevent power cycling.

The third option also applies power after the LTC4257-1, while omitting diode D9. With the diode omitted, the transformer voltage is applied to the LTC4257-1 in addition to the load. For this reason, it is necessary to ensure

# APPLICATIONS INFORMATION

OPTION 1: AUXILIARY POWER INSERTED BEFORE LTC4257-1

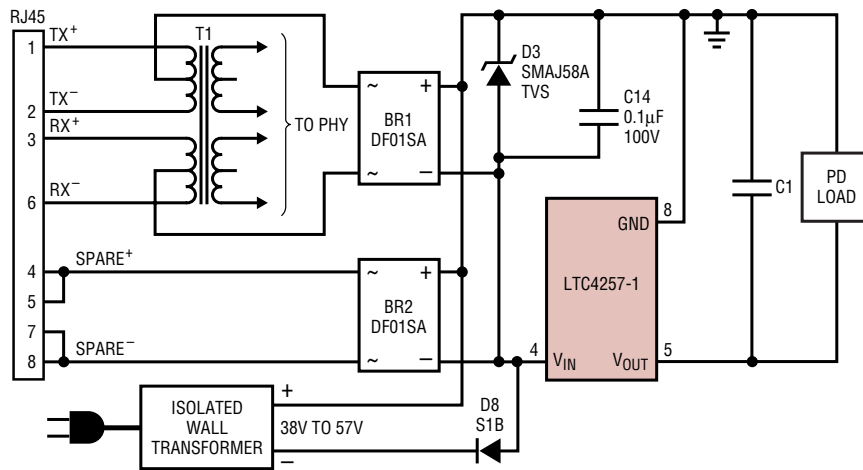

OPTION 2: AUXILIARY POWER INSERTED AFTER LTC4257-1 WITH SIGNATURE DISABLED

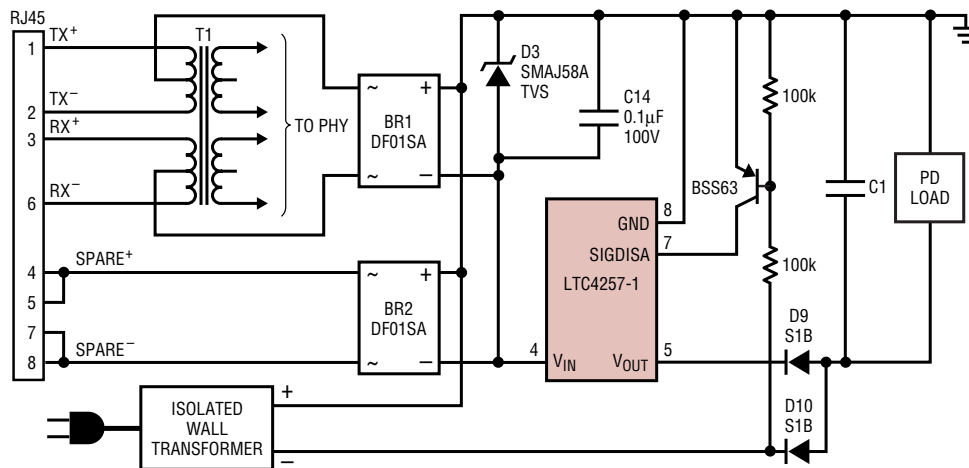

OPTION 3: AUXILIARY POWER APPLIED TO LTC4257-1 AND PD LOAD

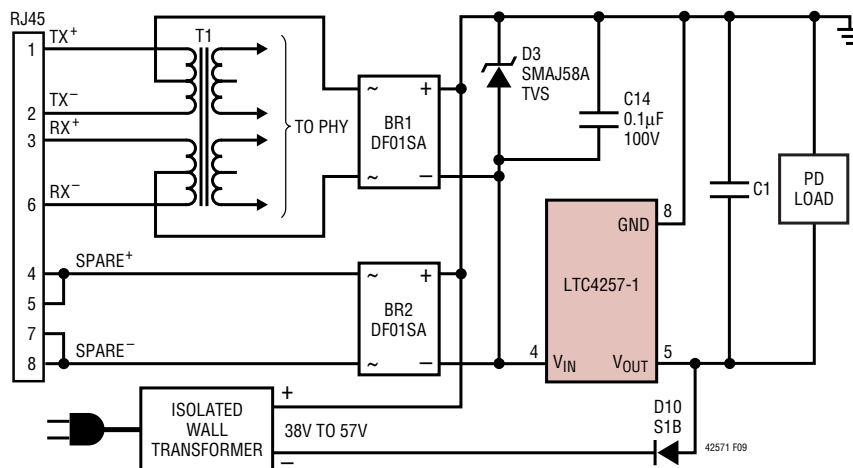

Figure 9. Auxiliary Power Source for PD

## APPLICATIONS INFORMATION

that the transformer maintain the voltage between 38V and 57V to keep the LTC4257-1 in its normal operating range. The third option has the advantage of automatically disabling the 25k signature when the external voltage exceeds the PSE voltage.

### Classification Resistor Selection ( $R_{CLASS}$ )

The IEEE specification allows classifying PDs into four distinct classes with class 4 being reserved for future use (Table 2). An external resistor connected from  $R_{CLASS}$  to  $V_{IN}$  (Figure 4) sets the value of the load current. The designer should determine which power category the PD falls into and then select the appropriate value of  $R_{CLASS}$  from Table 2. If a unique load current is required, the value of  $R_{CLASS}$  can be calculated as:

$$R_{CLASS} = 1.237V / (I_{DESIRED} - I_{IN\_CLASS})$$

where  $I_{IN\_CLASS}$  is the LTC4257-1 IC supply current during classification and is given in the electrical specifications. The  $R_{CLASS}$  resistor must be 1% or better to avoid degrading the overall accuracy of the classification circuit. Resistor power dissipation will be 50mW maxi-

um and is transient so heating is typically not a concern. In order to maintain loop stability, the layout should minimize capacitance at the  $R_{CLASS}$  node. The classification circuit can be disabled by floating the  $R_{CLASS}$  pin. The  $R_{CLASS}$  pin should not be shorted to  $V_{IN}$  as this would force the LTC4257-1 classification circuit to attempt to source very large currents. In this case, the LTC4257-1 will quickly go into thermal shutdown.

### Power Good Interface

The PWRGD signal is controlled by a high voltage, open-drain transistor. Examples of active-high and active-low interface circuits for controlling the PD load are shown in Figure 10.

In some applications it is desirable to ignore intermittent power bad conditions. This can be accomplished by including capacitor C15 in Figure 10 to form a lowpass filter. With the components shown, power bad conditions less than about 200 $\mu$ s will be ignored. Conversely, in other applications it may be desirable to delay assertion of PWRGD to the PD load. The PWRGD signal can be delayed with the addition of capacitor C17 in Figure 10.

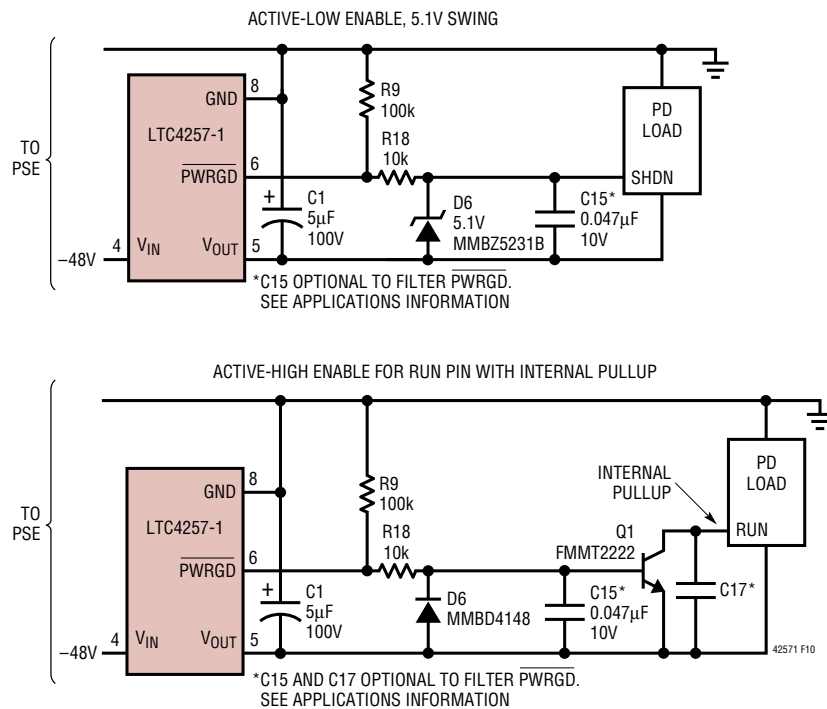

Figure 10. Power Good Interface Examples



## APPLICATIONS INFORMATION

### Signature Disable Interface

To disable the 25k signature, connect the SIGDISA pin to the GND pin. Alternately, SIGDISA can be driven high with respect to  $V_{IN}$ . An example of a signature disable interface circuit is shown in Figure 9, option 2. Note that the SIGDISA input resistance is relatively large and the threshold voltage is fairly low. Because of high voltages present on the printed circuit board, leakage currents from the GND pin could inadvertently pull SIGDISA high. To insure trouble-free operation, use high-voltage layout techniques in the vicinity of SIGDISA. If unused, connect SIGDISA to  $V_{IN}$ .

### Load Capacitor

The IEEE 802.3af specification requires that the PD maintain a minimum load capacitance of 5 $\mu$ F. It is permissible to have a much larger load capacitor and the LTC4257-1 can charge very large load capacitors before thermal issues become a problem. However, the load capacitor must not be too large or the PD design may violate IEEE 802.3af requirements.

If the load capacitor is too large there can be a problem with inadvertent power shutdown by the PSE. Consider the following scenario. If the PSE is running at  $-57V$  (maximum allowed) and the PD has been detected and powered up, the load capacitor will be charged to nearly  $-57V$ . If for some reason the PSE voltage suddenly is reduced to  $-44V$  (minimum allowed), the input bridge will reverse bias and PD power will be supplied solely by the load capacitor. Depending on the size of the load capacitor and the DC load of the PD, the PD will not draw any power from the PSE for a period of time. If this period of time exceeds the IEEE 802.3af 300ms disconnect delay, the PSE may remove power from the PD. For this reason, it is necessary to evaluate the load capacitance and load current to ensure that inadvertent shutdown cannot occur.

Very small output capacitors ( $\leq 10\mu$ F) will charge very quickly in current limit. The rapidly changing voltage at the output may reduce the current limit temporarily, causing the capacitor to charge at a somewhat reduced rate. Conversely, charging very large capacitors may cause the current limit to increase slightly. In either case, once the output voltage reaches its final value, the input current limit will be restored to its nominal value.

### Maintain Power Signature

In an IEEE 802.3af system, the PSE uses the *maintain power signature* (MPS) to determine if a PD continues to require power. The MPS requires the PD to periodically draw at least 10mA and also have an AC impedance less than 26.25k $\Omega$  in parallel with 0.05 $\mu$ F. The PD application circuits shown in this data sheet meet the requirements necessary to maintain power. If either the DC current is less than 10mA or the AC impedance is above 26.25k $\Omega$ , the PSE might disconnect power. The DC current must be less than 5mA and the AC impedance must be above 2M $\Omega$  to guarantee power will be removed.

### Layout

The LTC4257-1 is relatively immune to layout problems. Excessive parasitic capacitance on the  $R_{CLASS}$  pin should be avoided. If using the DD package, include an electrically isolated heat sink to which the exposed pad on the bottom of the package can be soldered. For optimum thermal performance, make the heatsink as large as possible. Voltages in a PD can be as large as  $-57V$ , so high voltage layout techniques should be employed.

The load capacitor connected between Pins 5 and 8 of the LTC4257-1 can store significant energy when fully charged. The design of a PD must ensure that this energy is not inadvertently dissipated in the LTC4257-1. The polarity-protection diode(s) prevent an accidental short on the cable from causing damage. However, if the  $V_{IN}$  pin is shorted to the GND pin inside the PD while the load capacitor is charged, current will flow through the parasitic body diode of the internal MOSFET and may cause permanent damage to the LTC4257-1.

### Electro Static Discharge and Surge Suppression

The LTC4257-1 is specified to operate with an absolute maximum voltage of  $-100V$  and is designed to tolerate brief overvoltage events. However, the pins that interface to the outside world (primarily  $V_{IN}$  and GND) can routinely see peak voltages in excess of 10kV. To protect the LTC4257-1, it is highly recommended that a transient voltage suppressor be installed between the bridge and the LTC4257-1 (D3 in Figure 2).



# PACKAGE DESCRIPTION

## S8 Package 8-Lead Plastic Small Outline (Narrow .150 Inch) (Reference LTC DWG # 05-08-1610)

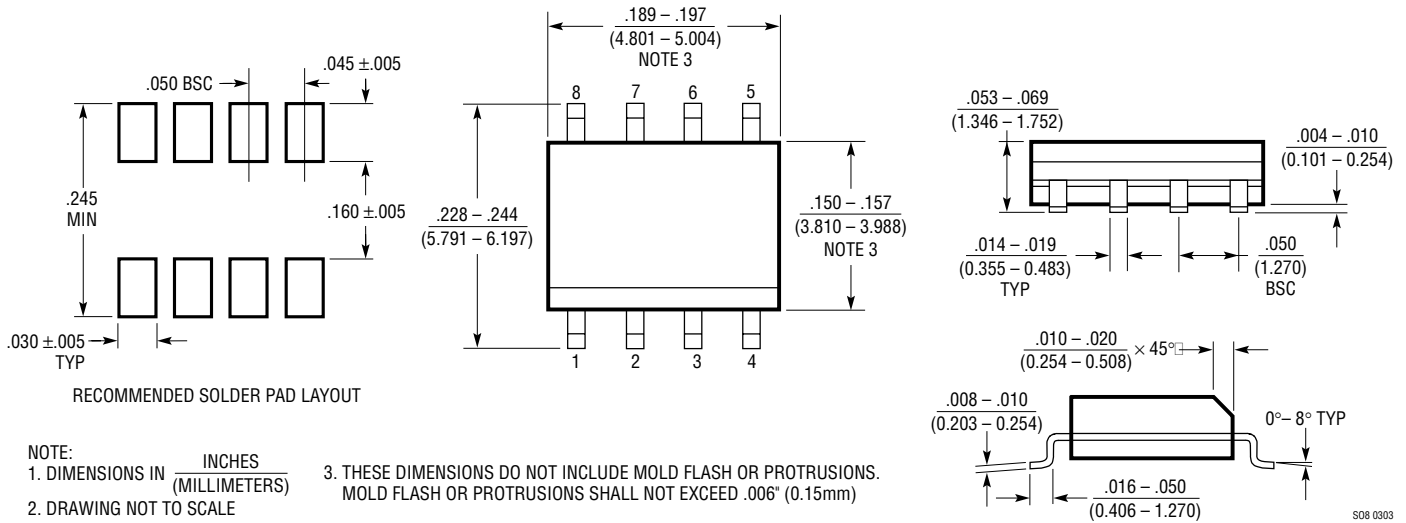

## DD Package 8-Lead Plastic DFN (3mm x 3mm) (Reference LTC DWG # 05-08-1698)

