

# Synchronous Buck-Boost MAIN/CAMERA White LED Driver

## FEATURES

- **High Efficiency:**  $\geq 85\%$  Over Entire Li-Ion Battery Range
- **Wide  $V_{IN}$  Range:** 2.7V to 5.5V
- **Independent MAIN/CAMERA Current Control**
- **Up to 425mA Continuous Output Current**
- **Internal Soft-Start**
- **Open/Shorted LED Protection**
- **PWM Brightness Control**
- **LED Current Matching Typically  $< 2.5\%$**
- **Constant Frequency 1MHz Operation**
- **Low Shutdown Current:** 6.5 $\mu$ A
- **Overtemperature Protection**
- **Small Thermally Enhanced 20-Lead** (4mm  $\times$  4mm) QFN Package

## APPLICATIONS

- Cell Phones
- Digital Cameras
- PDAs
- Portable Devices

 LTC and LT are registered trademarks of Linear Technology Corporation. All other trademarks are the property of their respective owners.

## DESCRIPTION

The LTC<sup>®</sup>3452 is a synchronous buck-boost DC/DC converter optimized for driving two banks of white LEDs from a single Li-Ion battery input. Five parallel LEDs can be driven at up to 25mA each in the low power LED bank, while two LEDs can be driven at up to 150mA each (or a single LED at 300mA) in the high power LED bank. The regulator operates in either synchronous buck, synchronous boost or buck-boost mode, depending on input voltage and LED maximum forward voltage. Optimum efficiency is achieved by sensing which LED requires the largest forward voltage drop at its programmed current, and regulating the common output rail for lowest dropout. Efficiency of 85% can be achieved over the entire usable range of a Li-Ion battery (2.7V to 4.2V).

Maximum LED current for each LED display is programmable with a single external resistor. Dual enable pins allow for PWM brightness control in the low power bank and independent on/off control for the high current bank (optimal for LED camera flash). In shutdown, the supply current is only 6.5 $\mu$ A.

A high constant operating frequency of 1MHz allows the use of a small external inductor. The LTC3452 is offered in a low profile (0.75mm) thermally enhanced 20-lead (4mm  $\times$  4mm) QFN package.

## TYPICAL APPLICATION

5  $\times$  20mA White LED Display + 200mA Camera Light Driver

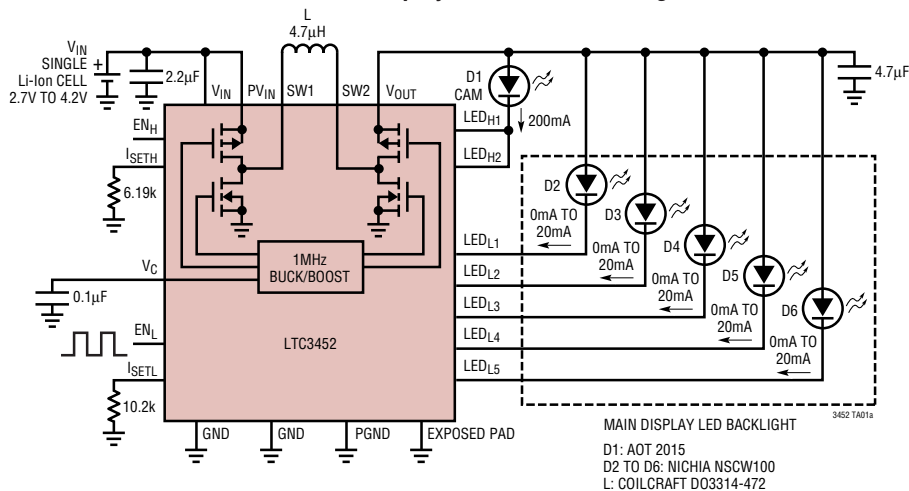

Torch and Flash Mode Efficiency

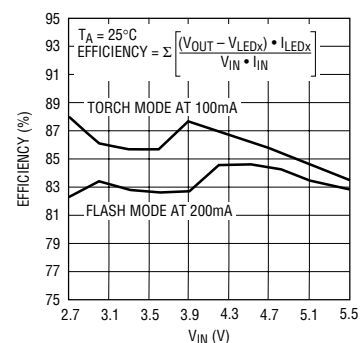

## ABSOLUTE MAXIMUM RATINGS

(Note 1)

$V_{IN}$ ,  $PV_{IN}$ , SW1, SW2,  $V_{OUT}$  Voltage ..... -0.3V to 6V  
 $LED_{L1}$  to  $LED_{L5}$  Voltage ... -0.3V to ( $V_{OUT} + 0.3V$ ) or 6V  
 $LED_{H1}$ ,  $LED_{H2}$  Voltage ..... -0.3V to ( $V_{OUT} + 0.3V$ ) or 6V  
 $V_C$ ,  $EN_L$ ,  $EN_H$ ,  
 $I_{SETL}$ ,  $I_{SETH}$  Voltage ..... -0.3V to ( $V_{IN} + 0.3V$ ) or 6V  
 $LED_{L1}$  to  $LED_{L5}$  Current ..... 50mA  
 $LED_{H1}$ ,  $LED_{H2}$  Current ..... 250mA  
 Operating Temperature Range (Note 2) .. -40°C to 85°C  
 Junction Temperature (Note 3) ..... 125°C  
 Storage Temperature Range ..... -65°C to 125°C

## PACKAGE/ORDER INFORMATION

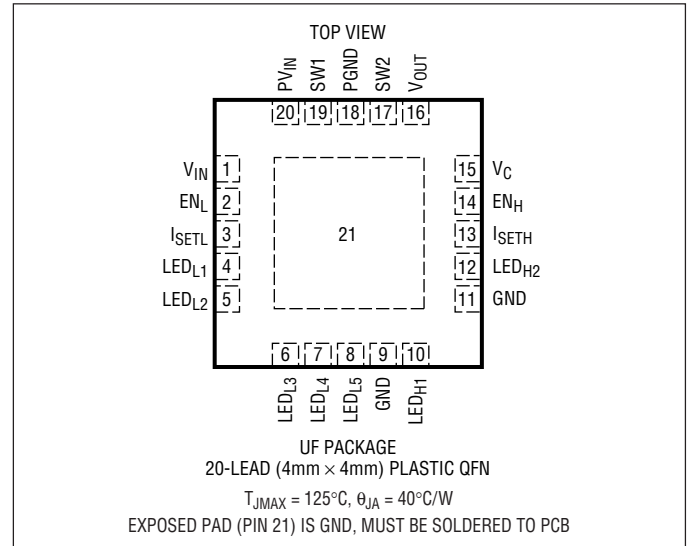

ORDER PART NUMBER	UF PART MARKING
LTC3452EUF	3452
<b>Order Options</b> Tape and Reel: Add #TR Lead Free: Add #PBF Lead Free Tape and Reel: Add #TRPBF Lead Free Part Marking: <a href="http://www.linear.com/leadfree/">http://www.linear.com/leadfree/</a>	

Consult LTC Marketing for parts specified with wider operating temperature ranges.

## ELECTRICAL CHARACTERISTICS

The ● denotes specifications which apply over the full operating temperature range, otherwise specifications are  $T_A = 25^{\circ}C$ .  
 $V_{IN} = PV_{IN} = V_{OUT} = 3.6V$  unless otherwise specified. (Note 2)

PARAMETER	CONDITIONS	MIN	TYP	MAX	UNITS	
Input Supply Voltage ( $V_{IN}$ )		● 2.7		5.5	V	
Input DC Supply Current						
Normal Operation	$2.7V \leq V_{IN} \leq 5.5V$ , $R_{ISETL} = R_{ISETH} = 51.1k$ , $I_{LEDx} = 0$ (Note 4)		0.6	1	mA	
Shutdown	$2.7V \leq V_{IN} \leq 5.5V$ , $V_{ENL} = V_{ENH} = 0V$		6.5	18	$\mu A$	
UVLO	$V_{IN} < UVLO$ Threshold		3	5	$\mu A$	
Undervoltage Lockout Threshold	$V_{IN}$ Rising	●	2.0	2.3	V	
	$V_{IN}$ Falling	1.6	1.87		V	
$EN_{L,H}$ DC Threshold for Normal Operation ( $V_{IH}$ )	$2.7V \leq V_{IN} \leq 5.5V$ , $V_{ENL,H}$ Rising	●	0.54	1.2	V	
$EN_{L,H}$ DC Threshold for Shutdown ( $I_{LEDx} = 0$ ) ( $V_{IL}$ )	$2.7V \leq V_{IN} \leq 5.5V$ , $V_{ENL,H}$ Falling	●	0.2	0.52	V	
$EN_{L,H}$ Input Current ( $I_{IH}$ , $I_{IL}$ )	$2.7V \leq V_{IN} \leq 5.5V$	●	-1	1	$\mu A$	
$EN_L$ PWM Frequency	$2.7V \leq V_{IN} \leq 5.5V$ (Note 5)	●	10		kHz	
$I_{SETL,H}$ Servo Voltage	$R_{ISETL} = R_{ISETH} = 20k$		788	800	812	mV
		●	780	800	812	mV
$LED_{Hx}$ Output Current Ratio ( $I_{LEDHx}/I_{SETH}$ )	$I_{LEDHx} = 100mA$ , $V_{LEDHx} = 300mV$		730	768	806	mA/mA
		●	714	768	806	mA/mA
$LED_{Hx}$ Output Current Matching	$(Max - Min)/[(Max + Min)/2] \cdot 100\%$ , $I_{LEDHx} = 100mA$ , $V_{LEDHx} = 300mV$ , $2.7V \leq V_{IN} \leq 5.5V$		1	6	%	
$LED_{Hx}$ Pin Voltage	$I_{LEDHx} = 100mA$		250		mV	

## ELECTRICAL CHARACTERISTICS

The ● denotes specifications which apply over the full operating temperature range, otherwise specifications are  $T_A = 25^\circ\text{C}$ .  
 $V_{IN} = PV_{IN} = V_{OUT} = 3.6\text{V}$  unless otherwise specified. (Note 2)

PARAMETER	CONDITIONS	MIN	TYP	MAX	UNITS
LED <sub>LX</sub> Output Current Ratio ( $I_{LEDLX}/I_{SETL}$ ) (Note 6)	$I_{LEDLX MAX} = 20\text{mA}$ , $V_{LEDLX} = 300\text{mV}$ PWM Duty Cycle = 6%	● 1.8	2	2.16	mA/mA
		1.75	2	2.21	mA/mA
	PWM Duty Cycle = 19%	● 3.66	4	4.28	mA/mA
		3.56	4	4.38	mA/mA
	PWM Duty Cycle = 31%	● 7.32	8	8.56	mA/mA
		7.12	8	8.76	mA/mA
	PWM Duty Cycle = 44%	● 14.72	16	17.04	mA/mA
		14.32	16	17.44	mA/mA
PWM Duty Cycle = 56%	● 29.44	32	33.92	mA/mA	
	28.64	32	34.56	mA/mA	
PWM Duty Cycle = 69%	● 58.88	64	67.2	mA/mA	
	57.92	64	68.16	mA/mA	
PWM Duty Cycle = 81%	● 117.12	128	134.4	mA/mA	
	114.56	128	137.6	mA/mA	
PWM Duty Cycle = 94%	● 234.24	256	268.8	mA/mA	
	229.12	245	272.64	mA/mA	
LED <sub>LX</sub> Output Current Matching	(Max – Min)/[(Max + Min)/2] • 100%, $I_{LEDLX} = 20\text{mA}$ , $V_{LEDLX} = 300\text{mV}$		2.5	8	%
LED <sub>LX</sub> Pin Voltage	$I_{LEDLX} = 20\text{mA}$		130		mV
Regulated Maximum $V_{OUT}$	$V_{LEDLX} = V_{LEDHY} = 0\text{V}$	● 4.35	4.5	4.75	V
PMOS Switch $R_{ON}$	Switches A and D at 100mA		210		m $\Omega$
NMOS Switch $R_{ON}$	Switches B and C at 100mA		205		m $\Omega$
Forward Current Limit	Switch A	1000	1600	2400	mA
Reverse Current Limit	Switch D		200		mA
PMOS Switch Leakage	Switches A and D	–1		1	$\mu\text{A}$
NMOS Switch Leakage	Switches B and C	–1		1	$\mu\text{A}$
Oscillator Frequency		0.9	1	1.1	MHz
Soft-Start Time			650		$\mu\text{s}$

**Note 1:** Stresses beyond those listed under Absolute Maximum Ratings may cause permanent damage to the device. Exposure to any Absolute Maximum Rating condition for extended periods may affect device reliability and lifetime.

**Note 2:** The LTC3452E is guaranteed to meet specifications from  $0^\circ\text{C}$  to  $70^\circ\text{C}$ . Specifications over the  $-40^\circ\text{C}$  to  $85^\circ\text{C}$  operating temperature range are assured by design, characterization and correlation with statistical process controls.

**Note 3:**  $T_J$  is calculated from the ambient temperature  $T_A$  and power dissipation  $P_D$  according to the following formula:

$$T_J = T_A + (P_D \cdot \theta_{JA}^\circ\text{C/W}).$$

**Note 4:** Dynamic supply current is higher due to the gate charge being delivered at the switching frequency.

**Note 5:** Do not exceed 50kHz PWM frequency in the application.

**Note 6:** This parameter is tested in a setup which forces conditions equivalent to those programmed by the indicated duty cycle.

# TYPICAL PERFORMANCE CHARACTERISTICS

Shutdown Current vs Temperature

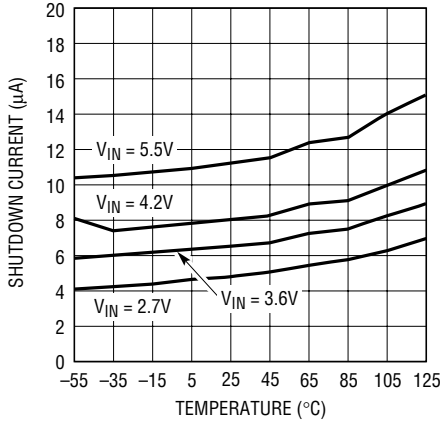

3452 G01

Shutdown Current vs  $V_{IN}$

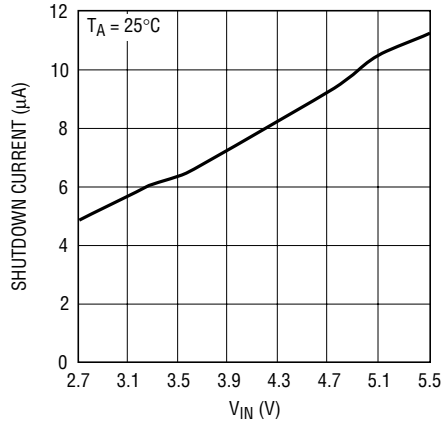

3452 G02

Undervoltage Lockout Threshold vs Temperature

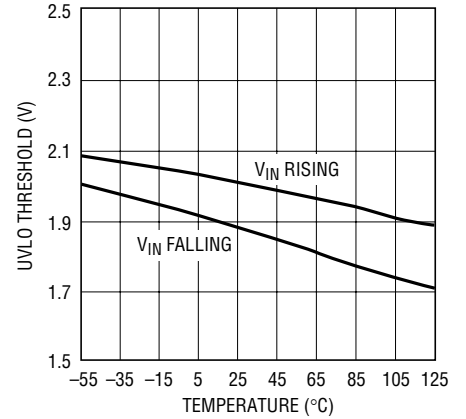

3452 G03

Enable Thresholds vs Temperature

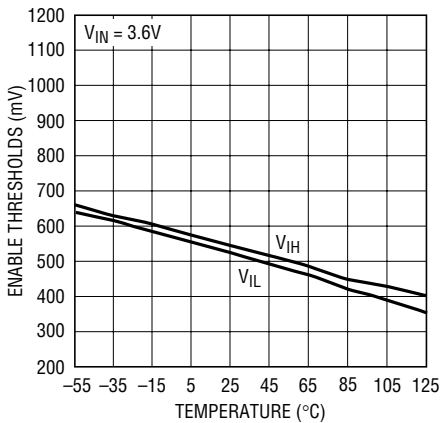

3452 G04

Enable Thresholds vs  $V_{IN}$

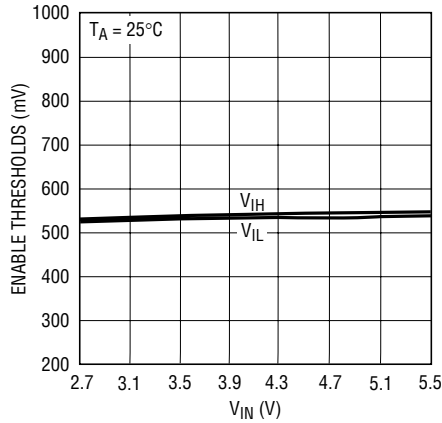

3452 G05

$I_{SETL,H}$  Servo Voltage vs Temperature

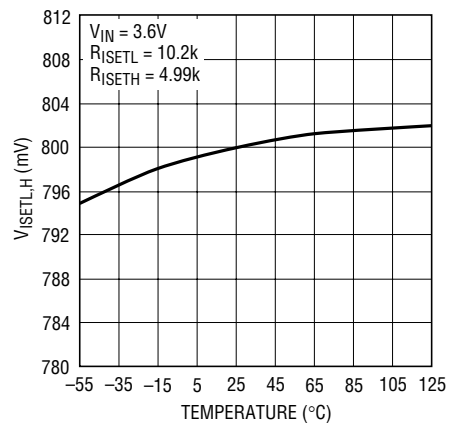

3452 G06

$I_{SETL,H}$  Servo Voltage vs  $V_{IN}$

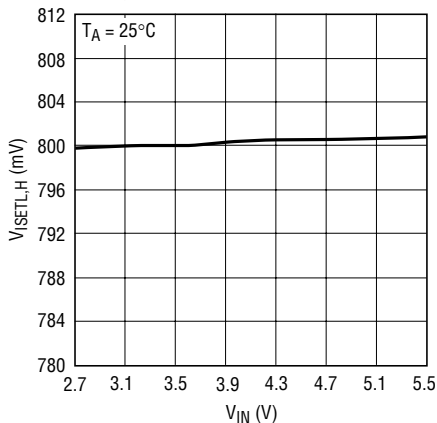

3452 G07

Maximum Regulated  $V_{OUT}$  vs Temperature

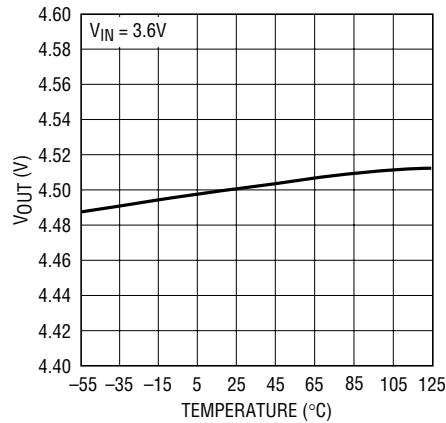

3452 G08

# TYPICAL PERFORMANCE CHARACTERISTICS

PMOS  $R_{DS(ON)}$  vs Temperature

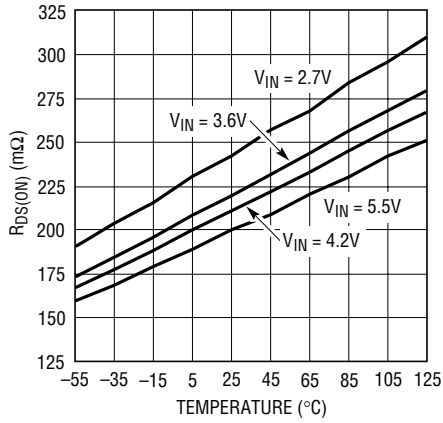

3452 G10

NMOS  $R_{DS(ON)}$  vs Temperature

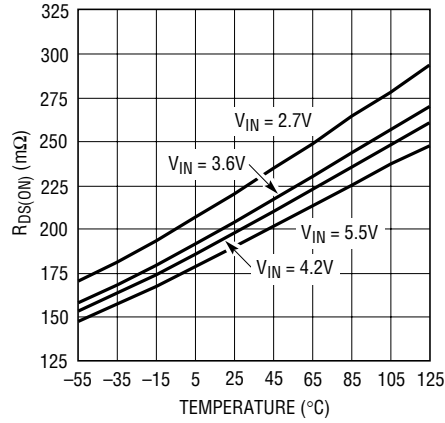

3452 G11

Oscillator Frequency vs Temperature

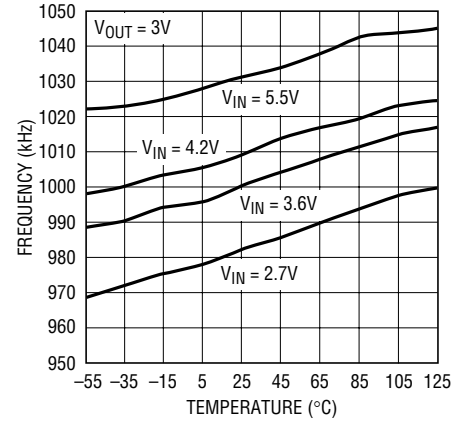

3452 G12

Output Voltage Ripple (Front Page Application)

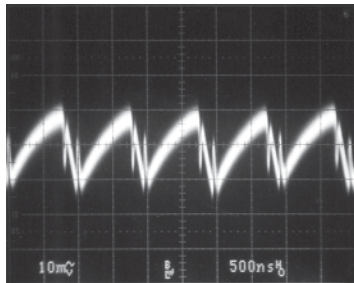

3452 G13

$V_{IN} = 3V$   
 $V_{OUT} = 3.1V$   
 $I_{LED} = 100mA$

Start-Up Transient

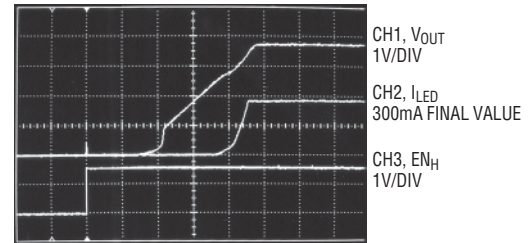

3452 G14

$V_{IN} = 3.6V$   
 $I_{LEDH} = 300mA$

## PIN FUNCTIONS

**V<sub>IN</sub> (Pin 1):** Signal Voltage Input Supply Pin ( $2.7V \leq V_{IN} \leq 5.5V$ ). Recommended bypass capacitor to GND is 2.2 $\mu$ F ceramic or larger. Connect to PV<sub>IN</sub> (Pin 20).

**EN<sub>L</sub> (Pin 2):** Enable Input Pin and PWM Brightness Control for Low Power LED Bank. Active high. For constant I<sub>MAXL</sub> operation, connect the EN<sub>L</sub> pin to V<sub>IN</sub> (or any voltage >1.2V). For EN<sub>L</sub> voltage <0.2V, all low power bank LED current source outputs are Hi-Z (if both EN<sub>L</sub> and EN<sub>H</sub> are <0.2V, the part is in shutdown and the input supply current drops to ~6 $\mu$ A). For brightness control between zero current and I<sub>MAXL</sub>, drive the EN<sub>L</sub> pin with a PWM waveform of frequency  $\geq 10kHz$ . The low power LED bank currents will be equal to a percentage of I<sub>MAXL</sub> as given in Table 1. The EN<sub>L</sub> pin is high impedance and should not be floated.

**I<sub>SETL</sub> (Pin 3):** Low Power LED Bank Current Programming Pin. A resistor to ground programs each low power bank current source output maximum to  $I_{LEDLxMAX} = 256 \cdot (0.8V/R_{ISETL})$ . Enabled by EN<sub>L</sub> (Pin 2). PWM brightness control also via EN<sub>L</sub>.

**LED<sub>L1</sub> to LED<sub>L5</sub> (Pins 4 to 8):** Individual Low Dropout Current Source Outputs for Low Power LED Bank Current Biasing. Connect each low power LED between V<sub>OUT</sub> and an individual LED<sub>Lx</sub> pin. Unused LED<sub>Lx</sub> outputs should be connected to V<sub>OUT</sub>.

**GND (Pins 9 and 11):** Signal Ground Pins. Connect together and to PGND (Pin 18) and Exposed Pad ground (Pin 21).

**LED<sub>H1</sub>, LED<sub>H2</sub> (Pins 10, 12):** Individual Low Dropout Current Source Outputs for High Power LED Bank Current Biasing. Connect each high power LED between V<sub>OUT</sub> and an individual LED<sub>Hx</sub> pin. Unused LED<sub>Hx</sub> outputs should be connected to V<sub>OUT</sub>.

**I<sub>SETH</sub> (Pin 13):** High Power LED Bank Current Programming Pin. A resistor to ground programs each high power bank current source output to  $I_{LEDHx} = 768(0.8V/R_{ISETH})$ . Enabled by EN<sub>H</sub> (Pin 14).

**EN<sub>H</sub> (Pin 14):** Enable Input Pin for High Power LED Bank. Active high. The EN<sub>H</sub> pin is high impedance and should not be floated.

**V<sub>C</sub> (Pin 15):** Compensation Point for the Internal Error Amplifier Output. Recommended compensation capacitor to GND is 0.1 $\mu$ F ceramic or larger.

**V<sub>OUT</sub> (Pin 16):** Buck-Boost Output Pin. Recommended bypass capacitor to GND is 4.7 $\mu$ F ceramic.

**SW2 (Pin 17):** Switching Node Pin. Connected to internal power switches C and D. External inductor connects between SW1 and SW2. Recommended value is 4.7 $\mu$ H.

**PGND (Pin 18):** Power Ground Pin. Connect to GND (Pins 9 and 11).

**SW1 (Pin 19):** Switching Node Pin. Connected to internal power switches A and B. External inductor connects between SW1 and SW2. Recommended value is 4.7 $\mu$ H.

**PV<sub>IN</sub> (Pin 20):** Power Voltage Input Supply Pin. Connect to V<sub>IN</sub> (Pin 1).

**Exposed Pad (Pin 21):** Heat Sink Ground. Connect to GND (Pins 9 and 11) and solder to PCB ground for electrical contact and rated thermal performance.

# BLOCK DIAGRAM

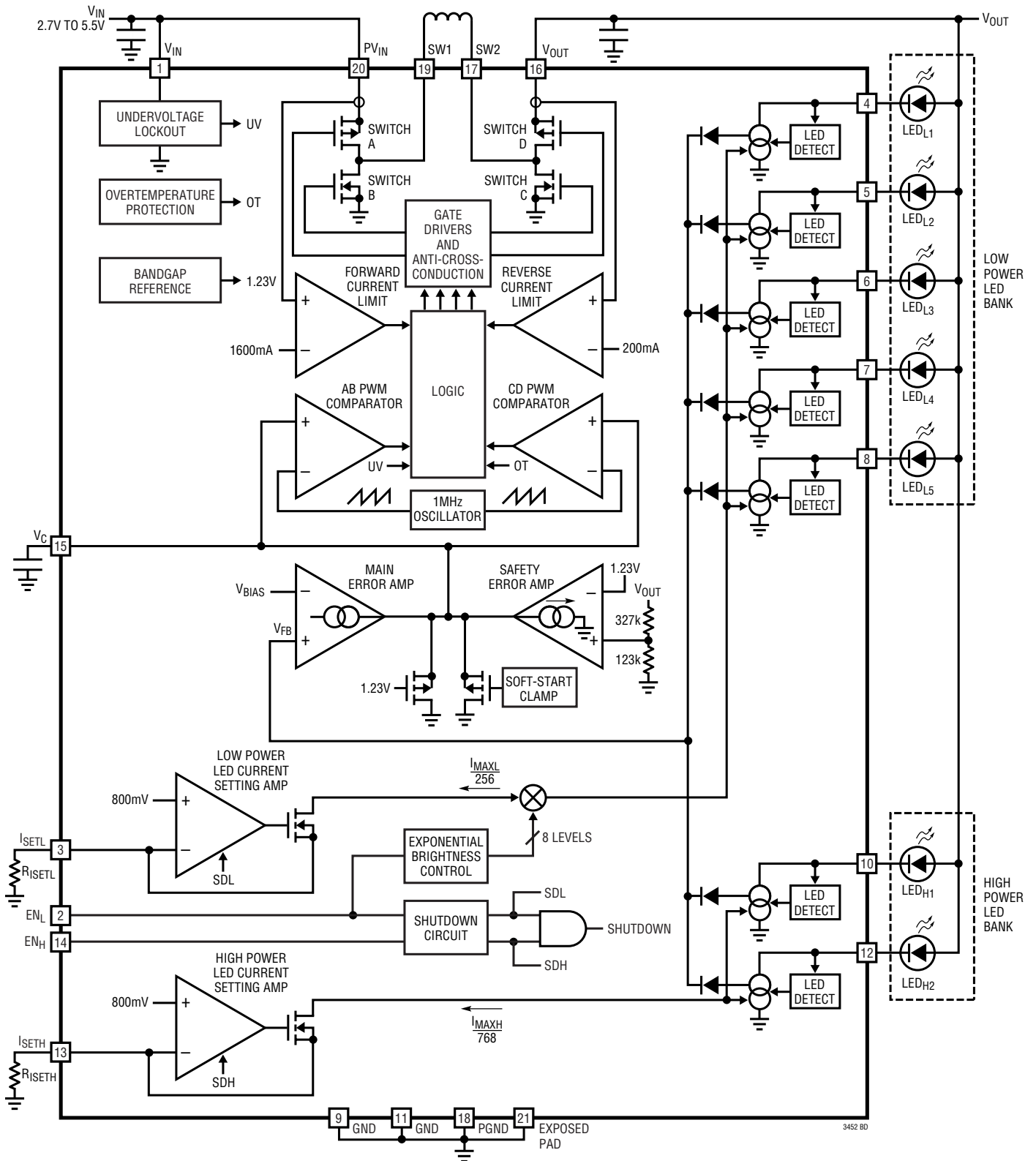

## OPERATION

### Buck-Boost DC-DC Converter

The LTC3452 employs an LTC proprietary buck-boost DC/DC converter to generate the output voltage required to drive the LEDs. This architecture permits high-efficiency, low noise operation at input voltages above, below or equal to the output voltage by properly phasing four internal power switches. The error amp output voltage on the  $V_C$  pin determines the duty cycle of the switches. Since the  $V_C$  pin is a filtered signal, it provides rejection of frequencies well below the factory trimmed switching frequency of 1MHz. The low  $R_{DS(ON)}$ , low gate charge synchronous switches provide high frequency pulse width modulation control at high efficiency. Schottky diodes across synchronous rectifier switch B and synchronous rectifier switch D are not required, but if used, do provide a lower voltage drop during the break-before-make time (typically 20ns), which improves peak efficiency by typically 1% to 2% at higher loads.

Figure 1 shows a simplified diagram of how the four internal power switches are connected to the inductor,  $V_{IN}$ ,  $V_{OUT}$  and GND. Figure 2 shows the regions of operation of the buck-boost as a function of the control voltage  $V_C$ . The output switches are properly phased so transitions between regions of operation are continuous, filtered and transparent to the user. When  $V_{IN}$  approaches  $V_{OUT}$ , the buck-boost region is reached where the conduction time of the four switch region is typically 150ns. Referring to Figures 1 and 2, the various regions of operation encountered as  $V_C$  increases will now be described.

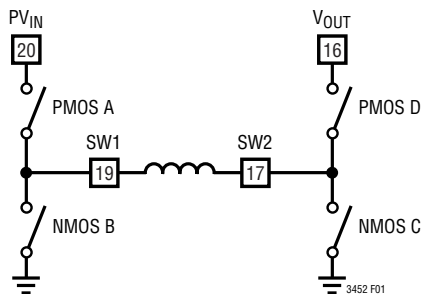

Figure 1. Simplified Diagram of Internal Power Switches

### Buck Mode ( $V_{IN} > V_{OUT}$ )

In buck mode, switch D is always on and switch C is always off. Referring to Figure 2, when the control voltage  $V_C$  is above voltage  $V_1$ , switch A begins to turn on each cycle. During the off time of switch A, synchronous rectifier switch B turns on for the remainder of the cycle. Switches A and B will alternate conducting similar to a typical synchronous buck regulator. As the control voltage increases, the duty cycle of switch A increases until the maximum duty cycle of the converter in buck mode reaches  $DC_{BUCK|max}$  given by:

$$DC_{BUCK|max} = 100\% - DC_{4SW}$$

where  $DC_{4SW}$  equals the duty cycle in % of the “four switch” range.

$$DC_{4SW} = (150ns \cdot f) \cdot 100\%$$

where  $f$  is the operating frequency in Hz.

Beyond this point the “four switch” or buck-boost region is reached.

### Buck-Boost or Four-Switch Mode ( $V_{IN} \approx V_{OUT}$ )

Referring to Figure 2, when the control voltage  $V_C$  is above voltage  $V_2$ , switch pair AD continue to operate for duty cycle  $DC_{BUCK|max}$ , and the switch pair AC begins to phase in. As switch pair AC phases in, switch pair BD phases out accordingly. When the  $V_C$  voltage reaches the edge of the buck-boost range at voltage  $V_3$ , switch pair AC completely phases out switch pair BD and the boost region begins at

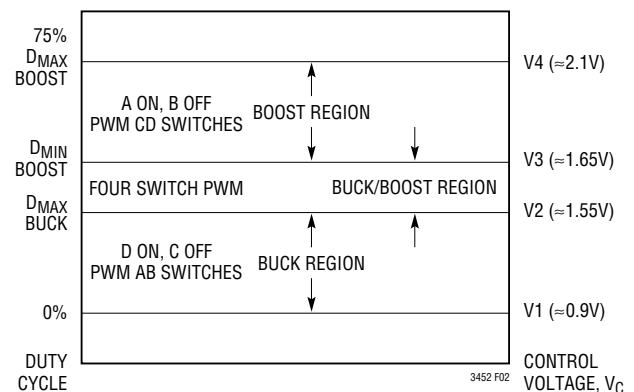

Figure 2. Switch Control vs Control Voltage,  $V_C$



## OPERATION

duty cycle  $DC_{4SW}$ . The input voltage  $V_{IN}$  where the four switch region begins is given by:

$$V_{IN} = \frac{V_{OUT}}{1 - (150\text{ns} \cdot f)}$$

and the input voltage  $V_{IN}$  where the four switch region ends is given by:

$$V_{IN} = V_{OUT} \cdot [1 - (150\text{ns} \cdot f)]$$

### Boost Mode ( $V_{IN} < V_{OUT}$ )

In boost mode, switch A is always on and switch B is always off. Referring to Figure 2, when the control voltage  $V_C$  is above voltage V3, switches C and D will alternate conducting similar to a typical synchronous boost regulator. The maximum duty cycle of the converter is limited to 88% typical and is reached when  $V_C$  is above V4.

### Forward Current Limit

If the current delivered from  $V_{IN}$  through PMOS switch A exceeds 1600mA (typical), switch A is shut off immediately. Switches B and D are turned on for the remainder of the cycle in order to safely discharge the forward inductor current at the maximum rate possible.

### Reverse Current Limit

If the current delivered from  $V_{OUT}$  backwards through PMOS switch D exceeds 200mA (typical), switch D is shut off immediately. Switches A and C are turned on for the remainder of the cycle in order to safely discharge the reverse inductor current at the maximum rate possible.

### Undervoltage Lockout

To prevent operation of the power switches at high  $R_{DS(ON)}$ , an undervoltage lockout is incorporated on the LTC3452. When the input supply voltage drops below approximately 1.9V, the four power switches and all control circuitry are turned off except for the undervoltage block, which draws only a few microamperes.

### Overtemperature Protection

If the junction temperature of the LTC3452 exceeds 130°C for any reason, all four switches are shut off immediately. The overtemperature protection circuit has a typical hysteresis of 11°C.

### Soft-Start

The LTC3452 includes an internally fixed soft-start which is active when powering up or coming out of shutdown. The soft-start works by clamping the voltage on the  $V_C$  node and gradually releasing it such that it requires 650 $\mu$ s to linearly slew from 0.9V to 2.1V. This has the effect of limiting the rate of duty cycle change as  $V_C$  transitions from the buck region through the buck-boost region into the boost region. Once the soft-start times out, it can only be reset by entering shutdown, or by an undervoltage or overtemperature condition.

### Main Error Amp

The main error amplifier is a transconductance amplifier with source and sink capability. The output of the main error amplifier drives a capacitor to GND at the  $V_C$  pin. This capacitor sets the dominant pole for the regulation loop. (See the Applications Information section for selecting the capacitor value.) The error amp gets its feedback signal from a proprietary circuit which monitors all 7 LED current sources to determine which LED to close the regulation loop on.

### Safety Error Amp

The safety error amplifier is a transconductance amplifier with sink only capability. In normal operation, it has no effect on the loop regulation. However, if any of the LED pins open-circuits, the output voltage will keep rising, and safety error amp will eventually take over control of the regulation loop to prevent  $V_{OUT}$  runaway. The  $V_{OUT}$  threshold at which this occurs is approximately 4.5V.

## OPERATION

### LED Current Setting Amps

The maximum forward current per LED for all LEDs in a given bank is programmed by a single external resistor to ground at the corresponding  $I_{SETL,H}$  pin according to the following formulas:

$$I_{MAXL} = 256 \left( \frac{0.8}{R_{ISETL}} \right), I_{MAXH} = 768 \left( \frac{0.8}{R_{ISETH}} \right)$$

For operation at currents below  $I_{MAXL}$  in the low power bank, refer to the Exponential Brightness Control section and also to external circuit options given in the Applications Section. For operation at currents below  $I_{MAXH}$  in the high power bank, refer only to the external circuit options given in the Applications Section.

### Shutdown Circuit

The shutdown circuit monitors the voltages at the  $EN_{L,H}$  pins. Logic high on either/both inputs enables the part and logic low on both puts the part in shutdown. Since the  $EN_L$  pin doubles as a PWM input for LED brightness control, an output filter in the shutdown circuit is employed to prevent the part from toggling in and out of shutdown for normal PWMing of the  $EN_L$  input when  $EN_H$  is low. If  $EN_H$  is low, the LTC3452 is enabled immediately after a rising edge at the  $EN_L$  pin, but waits 200 $\mu$ s (typical) after a falling edge to enter shutdown. Consequently, a minimum PWM frequency is required for smooth brightness control at currents below  $I_{MAXL}$ . The recommended PWM frequency is 10kHz to 50kHz.

### Exponential Brightness Control (Low Power LED Bank Only)

The LTC3452 implements an exponential brightness control function for the low power LED bank only in which the  $LED_{Lx}$  current is a function of the PWM duty cycle at the  $EN_L$  pin. The LED current will be equal to a fraction of  $I_{MAXL}$  as given in Table 1. As the duty cycle (that the PWM waveform is logic high) increases linearly, the LED current will increase exponentially from 1/128th  $I_{MAXL}$  to 128/128ths  $I_{MAXL}$  in seven binary steps. The function

implemented results in “smoother” brightness and dimming control as perceived by the human eye, which is logarithmic in nature.

**Table 1. Low Power Bank Brightness Control**

$EN_L$ DUTY CYCLE (% LOGIC HIGH)	$LED_{Lx}$ CURRENT
0% (Logic Low)	0 (Shutdown)
0% < Duty Cycle < 12.5%	1/128 • $I_{MAXL}$
12.5% < Duty Cycle < 25%	1/64 • $I_{MAXL}$
25% < Duty Cycle < 37.5%	1/32 • $I_{MAXL}$
37.5% < Duty Cycle < 50%	1/16 • $I_{MAXL}$
50% < Duty Cycle < 62.5%	1/8 • $I_{MAXL}$
62.5% < Duty Cycle < 75%	1/4 • $I_{MAXL}$
75% < Duty Cycle < 87.5%	1/2 • $I_{MAXL}$
87.5% < Duty Cycle $\leq$ 100%	$I_{MAXL}$

### LED Current Sources

Each LED pin is driven by a current source specifically designed for low dropout. The LTC3452 employs a proprietary architecture that determines which of the seven LEDs requires the largest forward voltage drop at its programmed current, and then generates a feedback voltage based on this one for closing the buck-boost regulation loop. This results in the lowest output voltage required for regulating all of the LEDs and thus the highest LED power efficiency. The voltage present at the LED pin of the “controlling LED” will be typically 130mV at 20mA (low power bank) or 250mA at 100mA (high power bank) of current.

### LED Detect Circuit

If fewer than five LED outputs in the low power bank and/or fewer than two LED outputs in the high power bank are required, unused outputs should be connected to  $V_{OUT}$ . Each LED pin has an internal LED detect circuit that disables the output current source to save power if an output is not needed. A small current is employed to detect the presence of an LED at startup. This current is typically 10 $\mu$ A for the low power bank and 30 $\mu$ A for the high power bank.

## APPLICATIONS INFORMATION

### COMPONENT SELECTION

#### Inductor Selection

The high frequency operation of the LTC3452 allows the use of small surface mount inductors. The inductor current ripple is typically set to 20% to 40% of the maximum average inductor current. For a given ripple the inductance term in boost mode is:

$$L > \frac{V_{IN(MIN)}^2 \cdot (V_{OUT} - V_{IN(MIN)}) \cdot 100\%}{f \cdot I_{OUT(MAX)} \cdot \%Ripple \cdot V_{OUT}^2}$$

and in buck mode is:

$$L > \frac{V_{OUT} \cdot (V_{IN(MAX)} - V_{OUT}) \cdot 100\%}{f \cdot I_{OUT(MAX)} \cdot \%Ripple \cdot V_{IN(MAX)}}$$

where:

f = operating frequency, Hz

%Ripple = allowable inductor current ripple, %

$V_{IN(MIN)}$  = minimum input voltage, V

$V_{IN(MAX)}$  = maximum input voltage, V

$V_{OUT}$  = output voltage, V

$I_{OUT(MAX)}$  = maximum output load current

For high efficiency, choose an inductor with a high frequency core material, such as ferrite, to reduce core losses. The inductor should have low ESR (equivalent series resistance) to reduce the  $I^2R$  losses, and must be able to handle the peak inductor current without saturating. Molded chokes or chip inductors usually do not have enough core to support peak inductor currents >1A. To minimize radiated noise, use a toroid, pot core or shielded bobbin inductor. For the white LED application, a 4.7 $\mu$ H inductor value is recommended. See Table 2 for a list of component suppliers.

**Table 2. Inductor Vendor Information**

SUPPLIER	WEB SITE
Coilcraft	www.coilcraft.com
Cooper/Coiltronics	www.cooperet.com
Murata	www.murata.com
Sumida	www.japanlink.com/sumida
Vishay-Dale	www.vishay.com

#### Input Capacitor Selection

Since the  $V_{IN}$  pin is the supply voltage for the IC it is recommended to place at least a 2.2 $\mu$ F, low ESR bypass capacitor to ground. See Table 3 for a list of component suppliers.

**Table 3. Capacitor Vendor Information**

SUPPLIER	WEB SITE
AVX	www.avxcorp.com
Sanyo	www.sanyovideo.com
Taiyo Yuden	www.t-yuden.com
TDK	www.component.tdk.com

#### Output Capacitor Selection

The bulk value of the capacitor is set to reduce the ripple due to charge into the capacitor each cycle. The steady state ripple due to charge is given by:

$$\%Ripple\_Boost = \frac{I_{OUT(MAX)} \cdot (V_{OUT} - V_{IN(MIN)}) \cdot 100}{C_{OUT} \cdot V_{OUT}^2 \cdot f} \%$$

$$\%Ripple\_Buck = \frac{(V_{IN(MAX)} - V_{OUT}) \cdot 100}{8 \cdot V_{IN(MAX)} \cdot f^2 \cdot L \cdot C_{OUT}} \%$$

where  $C_{OUT}$  = output filter capacitor, F

The output capacitance is usually many times larger in order to handle the transient response of the converter. For a rule of thumb, the ratio of the operating frequency to the unity-gain bandwidth of the converter is the amount the output capacitance will have to increase from the above calculations in order to maintain the desired transient response.

The other component of ripple is due to the ESR (equivalent series resistance) of the output capacitor. Low ESR capacitors should be used to minimize output voltage ripple. For surface mount applications, Taiyo Yuden, TDK, AVX ceramic capacitors, AVX TPS series tantalum capacitors or Sanyo POSCAP are recommended. For the white LED application, a 4.7 $\mu$ F capacitor value is recommended. See Table 3 for a list of component suppliers.

## APPLICATIONS INFORMATION

### Optional Schottky Diodes

Schottky diodes across the synchronous switches B and D are not required, but provide a lower drop during the break-before-make time (typically 20ns) of the NMOS to PMOS transition, improving efficiency. Use a Schottky diode such as an MBRM120T3 or equivalent. Do not use ordinary rectifier diodes, since the slow recovery times will compromise efficiency.

### Closing the Feedback Loop

The LTC3452 incorporates voltage mode PWM control. The control to output gain varies with operation region (Buck, Boost, Buck/Boost), but is usually no greater than 15. The output filter exhibits a double pole response given by:

$$f_{\text{FILTER\_POLE}} = \frac{1}{2 \cdot \pi \cdot \sqrt{L \cdot C_{\text{OUT}}}} \text{ Hz}$$

where  $C_{\text{OUT}}$  is the output filter capacitor.

The output filter zero is given by:

$$f_{\text{FILTER\_ZERO}} = \frac{1}{2 \cdot \pi \cdot R_{\text{ESR}} \cdot C_{\text{OUT}}} \text{ Hz}$$

where  $R_{\text{ESR}}$  is the capacitor equivalent series resistance.

A troublesome feature in Boost mode is the right-half plane zero (RHP), and is given by:

$$f_{\text{RHPZ}} = \frac{V_{\text{IN}}^2}{2 \cdot \pi \cdot I_{\text{OUT}} \cdot L \cdot V_{\text{OUT}}} \text{ Hz}$$

The loop gain is typically rolled off before the RHP zero frequency.

A simple Type I compensation network can be incorporated to stabilize the loop but at a cost of reduced bandwidth and slower transient response. To ensure proper phase margin, the loop is required to be crossed over a decade before the LC double pole.

The unity-gain frequency of the error amplifier with the Type I compensation is given by:

$$f_{\text{UG}} = \frac{g_m}{2 \cdot \pi \cdot C_{\text{VC}}}$$

where  $g_m$  is the error amp transconductance (typically 1/5.2k) and  $C_{\text{VC}}$  is the external capacitor to GND at the  $V_C$  pin. For the white LED application, a 0.1 $\mu$ F or greater capacitor value is recommended.

### Paralleling LED Outputs for Higher Current

Two or more LED output pins can be connected together in parallel to achieve higher output current in fewer than 7 LEDs. For a very high power LED such as a LumiLED, all 7 outputs can be connected in parallel for maximum total output current, as shown in the back page application of this data sheet.

### Maximum LED Current

As described in the Operation section, the maximum output LED currents are equal to:

$$I_{\text{MAXL}} = 256 \left( \frac{0.8\text{V}}{R_{\text{ISETL}}} \right)$$

and

$$I_{\text{MAXH}} = 768 \left( \frac{0.8\text{V}}{R_{\text{ISETH}}} \right)$$

Since the maximum LED current for the low power bank is 25mA, this sets a minimum limit on  $R_{\text{ISETL}}$  of:

$$R_{\text{MINL}} = 256 \left( \frac{0.8\text{V}}{25\text{mA}} \right) = 8192\Omega$$

Similarly, for the high power bank:

$$R_{\text{MINH}} = 768 \left( \frac{0.8\text{V}}{150\text{mA}} \right) = 4096\Omega$$

In addition, since the maximum continuous output current for the buck-boost is limited to 425mA, this may impose higher resistor value minimums if all outputs are used.

## APPLICATIONS INFORMATION

Although the LTC3452 can safely provide this current continuously, the external LED(s) may not be rated for this high a level of continuous current. Higher current levels in a single LED are generally reserved for pulsed applications, such as LED camera flash. This is accomplished by programming a high current with one or both of the  $R_{ISET}$  resistors and pulsing the appropriate enable pin or pins as shown in the back page application.

### Varying LED Brightness Linearly

Continuously variable LED brightness control can be achieved by interfacing directly to one or both of the  $I_{SET}$  pins. Figure 3 shows four such methods employing a voltage DAC, a current DAC, a simple potentiometer or a PWM input applied to the  $I_{SETL}$  pin for controlling the low power bank LED currents. These four techniques can be similarly applied to the  $I_{SETH}$  pin for controlling the high power bank LED currents.

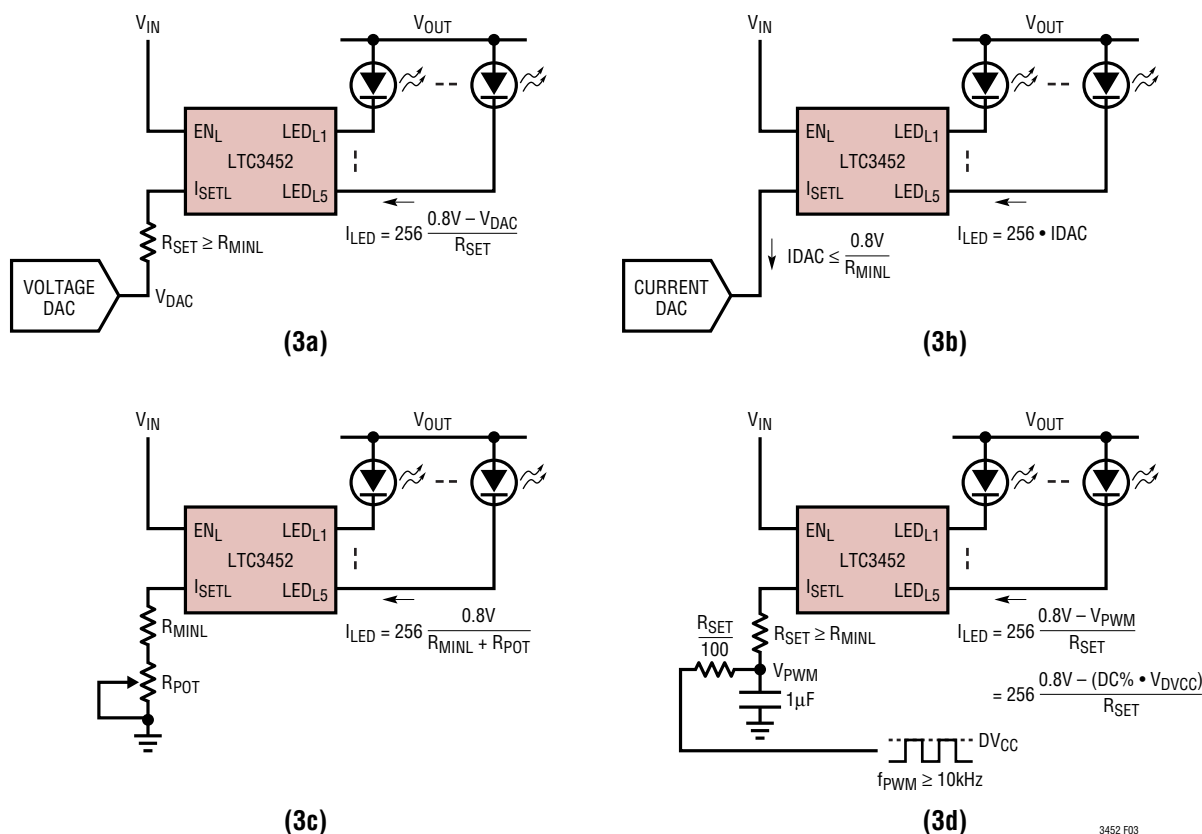

Figure 3. Additional Brightness Control Methods: (3a) Using Voltage DAC, (3b) Using Current DAC, (3c) Using Potentiometer, (3d) Using PWM Input

3452 F03

## APPLICATIONS INFORMATION

### Unused Outputs

If fewer than 7 LED pins are to be used, unused LEDx pins should be connected to  $V_{OUT}$ . The LTC3452 senses which current source outputs are not being used and shuts off the corresponding output currents to save power. A small trickle current (10 $\mu$ A: low power bank, 30 $\mu$ A: high power bank) is still applied to unused outputs to detect if a white LED is later switched in and also to distinguish unused outputs from used outputs during start-up.

### LED Failure Modes

If an individual LED fails as a short circuit, the current source biasing it is shut off to save power. This is the same operation as described previously (if the output were

initially designated unused at power-up by connecting its LEDx pin to  $V_{OUT}$ ). Efficiency is not materially affected.

If an individual LED fails as an open circuit, the control loop will initially attempt to regulate off of its current source feedback signal, since it will appear to be the one requiring the largest forward voltage drop to run at its programmed current. This will drive  $V_{OUT}$  higher. As the open circuited LED will never accept its programmed current,  $V_{OUT}$  must be voltage-limited by means of a secondary control loop. The LTC3452 limits  $V_{OUT}$  to 4.5V in this failure mode. The other LEDs will still remain biased at the correct programmed current but the overall circuit efficiency will decrease.

# PACKAGE DESCRIPTION

## UF Package 20-Lead Plastic QFN (4mm × 4mm) (Reference LTC DWG # 05-08-1710)

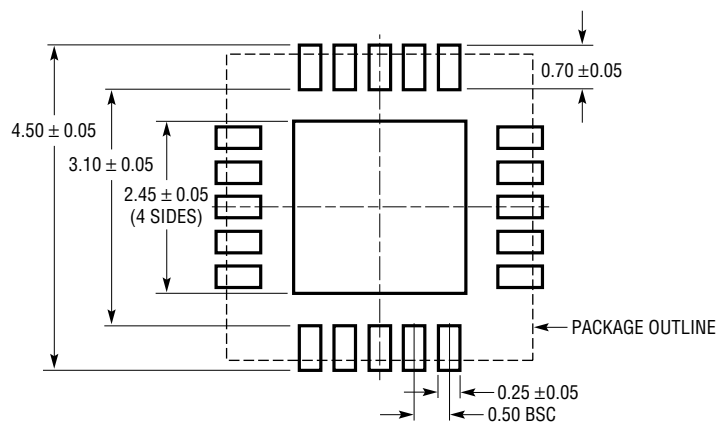

RECOMMENDED SOLDER PAD PITCH AND DIMENSIONS

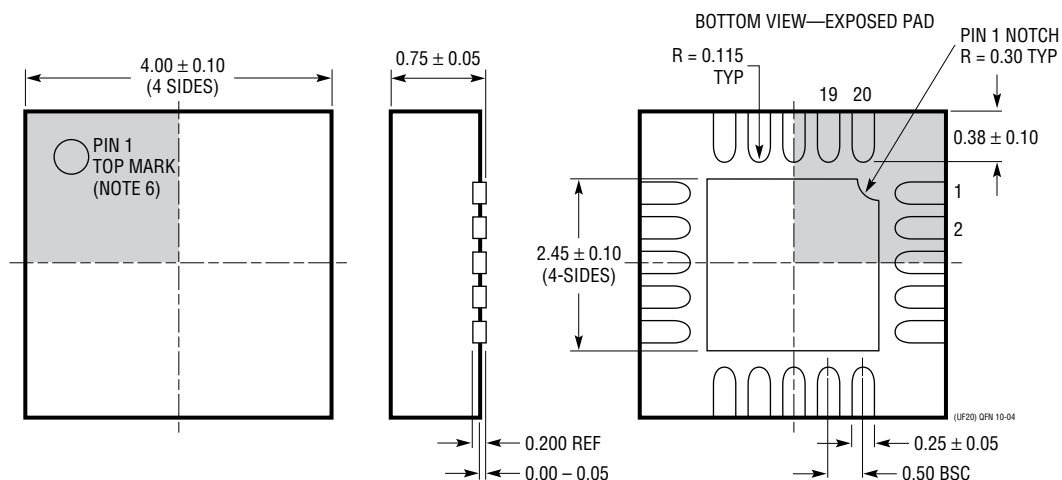

- NOTE:
1. DRAWING IS PROPOSED TO BE MADE A JEDEC PACKAGE OUTLINE MO-220 VARIATION (WGGD-1)—TO BE APPROVED
  2. DRAWING NOT TO SCALE
  3. ALL DIMENSIONS ARE IN MILLIMETERS
  4. DIMENSIONS OF EXPOSED PAD ON BOTTOM OF PACKAGE DO NOT INCLUDE MOLD FLASH. MOLD FLASH, IF PRESENT, SHALL NOT EXCEED 0.15mm ON ANY SIDE
  5. EXPOSED PAD SHALL BE SOLDER PLATED
  6. SHADED AREA IS ONLY A REFERENCE FOR PIN 1 LOCATION ON THE TOP AND BOTTOM OF PACKAGE