

1.9GHz Low Noise, Low Distortion Differential ADC Driver for DC-300MHz

FEATURES

- 1.9GHz -3dB Bandwidth
- Fixed Gain of 20V/V (26dB)
- -94dBc IMD3 at 70MHz (Equivalent OIP3 = 51dBm)
- -71dBc IMD3 at 300MHz (Equivalent OIP3 = 39.5dBm)
- 1nV/ $\sqrt{\text{Hz}}$ Internal Op Amp Noise
- 1.5nV/ $\sqrt{\text{Hz}}$ Total Input Referred Noise
- 6.8dB Noise Figure
- Differential Inputs and Outputs
- 50 Ω Input Impedance
- 2.85V to 3.5V Supply Voltage
- 85mA Supply Current (255mW)
- 1V to 1.6V Output Common Mode, Adjustable
- DC- or AC-Coupled Operation
- Max Differential Output Swing 4.7V_{P-P}
- Small 16-Lead 3mm × 3mm × 0.75mm QFN Package

APPLICATIONS

- Differential ADC Driver
- Differential Driver/Receiver
- Single Ended to Differential Conversion
- IF Sampling Receivers
- SAW Filter Interfacing

DESCRIPTION

The LTC[®]6400-26 is a high-speed differential amplifier targeted at processing signals from DC to 300MHz. The part has been specifically designed to drive 12-, 14- and 16-bit ADCs with low noise and low distortion, but can also be used as a general-purpose broadband gain block.

The LTC6400-26 is easy to use, with minimal support circuitry required. The output common mode voltage is set using an external pin, independent of the inputs, which eliminates the need of transformers or AC-coupling capacitors in many applications. The gain is internally fixed at 26dB (20V/V).

The LTC6400-26 saves space and power compared to alternative solutions using IF gain blocks and transformers. The LTC6400-26 is packaged in a compact 16-lead 3mm × 3mm QFN package and operates over the -40°C to 85°C temperature range.

LT, LT, LTC and LTM are registered trademarks of Linear Technology Corporation. All other trademarks are the property of their respective owners.

TYPICAL APPLICATION

Single-Ended to Differential ADC Driver at 140MHz IF

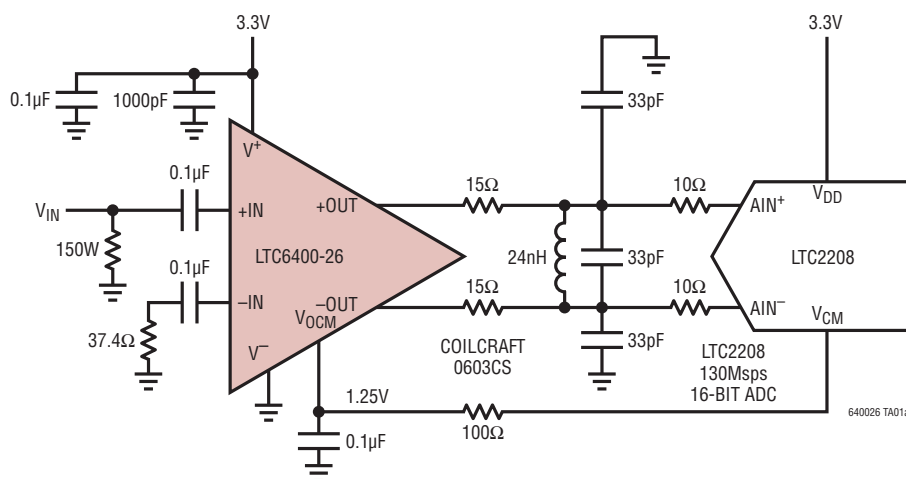

Equivalent OIP3 vs Frequency

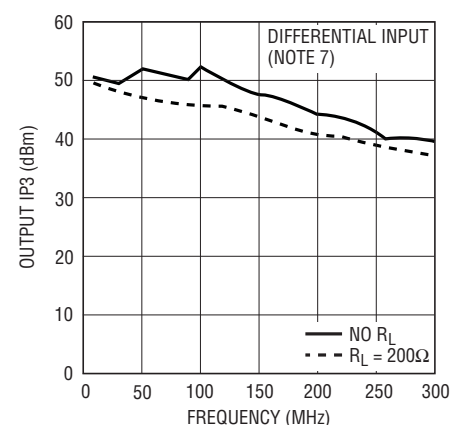

640026 TA01b

640026fa

ABSOLUTE MAXIMUM RATINGS

(Note 1)

Supply Voltage ($V^+ - V^-$).....	3.6V
Input Current (Note 2).....	$\pm 10\text{mA}$
Operating Temperature Range (Note 3)	-40°C to 85°C
Specified Temperature Range (Note 4)	-40°C to 85°C
Storage Temperature Range.....	-65°C to 150°C
Maximum Junction Temperature.....	150°C

PIN CONFIGURATION

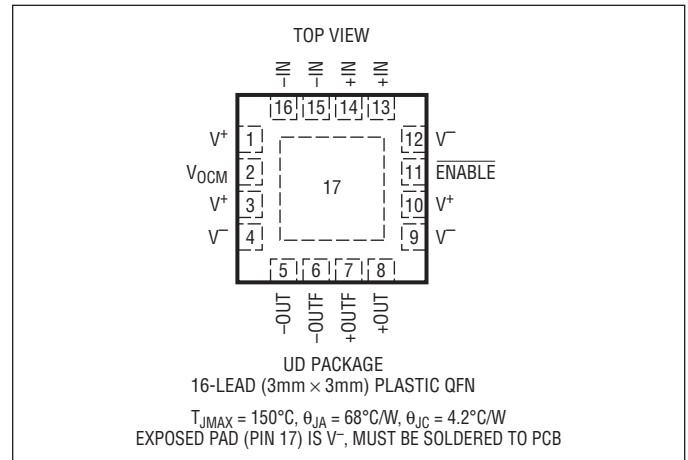

ORDER INFORMATION

LEAD FREE FINISH	TAPE AND REEL	PART MARKING*	PACKAGE DESCRIPTION	SPECIFIED TEMPERATURE RANGE
LTC6400CUD-26#PBF	LTC6400CUD-26#TRPBF	LCCX	16-Lead (3mm x 3mm) Plastic QFN	0°C to 70°C
LTC6400IUD-26#PBF	LTC6400IUD-26#TRPBF	LCCX	16-Lead (3mm x 3mm) Plastic QFN	-40°C to 85°C

Consult LTC Marketing for parts specified with wider operating temperature ranges. *The temperature grade is identified by a label on the shipping container. Consult LTC Marketing for information on non-standard lead based finish parts.

For more information on lead free part marking, go to: <http://www.linear.com/leadfree/>

For more information on tape and reel specifications, go to: <http://www.linear.com/tapeandreel/>

LTC6400 AND LTC6401 SELECTOR GUIDE Please check each datasheet for complete details.

PART NUMBER	GAIN (dB)	GAIN (V/V)	Z_{IN} (DIFFERENTIAL) (Ω)	I_S (mA)
LTC6400-20	20	10	200	90
LTC6400-26	26	20	50	85
LTC6401-8	8	2.5	400	45
LTC6401-20	20	10	200	50
LTC6401-26	26	20	50	45

In addition to the LTC6400 family of amplifiers, a lower power LTC6401 family is available. The LTC6401 is pin compatible to the LTC6400, and has the same low noise performance. The lower power consumption of the LTC6401 comes at the expense of slightly higher non-linearity, especially at input frequencies above 140MHz. Please refer to the separate LTC6401 data sheets for complete details. Other gain versions from 8dB to 14dB will follow.

DC ELECTRICAL CHARACTERISTICS The ● denotes the specifications which apply over the full operating temperature range, otherwise specifications are at $T_A = 25^\circ\text{C}$. $V^+ = 3\text{V}$, $V^- = 0\text{V}$, $+IN = -IN = V_{OCM} = 1.25\text{V}$, $ENABLE = 0\text{V}$, No R_L unless otherwise noted.

SYMBOL	PARAMETER	CONDITIONS	MIN	TYP	MAX	UNITS	
Input/Output Characteristic (+IN, -IN, +OUT, -OUT, +OUTF, -OUTF)							
G_{DIFF}	Gain	$V_{IN} = \pm 50\text{mV}$ Differential	●	25	26	27	dB
TC_{GAIN}	Gain Temperature Drift	$V_{IN} = \pm 50\text{mV}$ Differential	●	0.0038			dB/°C
$V_{SWINGMIN}$	Output Swing Low	Each Output, $V_{IN} = \pm 200\text{mV}$ Differential	●		90	160	mV
$V_{SWINGMAX}$	Output Swing High	Each Output, $V_{IN} = \pm 200\text{mV}$ Differential	●	2.35	2.48		V
$V_{OUTDIFFMAX}$	Maximum Differential Output Swing	1dB Compressed	●	4.38	4.7		V_{P-P}
I_{OUT}	Output Current Drive	Each Output, $V_{IN} = \pm 200\text{mV}$, $V_{OUT} > 2V_{P-P}$	●	20			mA
V_{OS}	Input Offset Voltage	Differential	●	-2		2	mV
TCV_{OS}	Input Offset Voltage Drift	Differential	●		1		$\mu\text{V}/^\circ\text{C}$
I_{VRMIN}	Input Common Mode Voltage Range, MIN					1	V
I_{VRMAX}	Input Common Mode Voltage Range, MAX			1.6			V
R_{INDIFF}	Input Resistance (+IN, -IN)	Differential	●	42.5	50	57.5	Ω
C_{INDIFF}	Input Capacitance	Differential, Includes Parasitics			1		pF
$R_{OUTDIFF}$	Output Resistance (+OUT, -OUT)	Differential	●	18	25	32	Ω
$R_{OUTFDIFF}$	Filtered Output Resistance (+OUTF, -OUTF)	Differential	●	85	100	115	Ω
$C_{OUTFDIFF}$	Filtered Output Capacitance (+OUTF, -OUTF)	Differential, Includes Parasitics			2.7		pF
CMRR	Common Mode Rejection Ratio	Input Common Mode Voltage 1.1V to 1.4V	●	50	75		dB
Output Common Mode Control							
G_{CM}	Common Mode Gain	$V_{OCM} = 1\text{V}$ to 1.6V			1		V/V
V_{OCMMIN}	Output Common Mode Range, MIN		●			1 1.1	V V
V_{OCMMAX}	Output Common Mode Range, MAX		●	1.6 1.5			V V
V_{OSCM}	Common Mode Offset Voltage	$V_{OCM} = 1.1\text{V}$ to 1.5V	●	-15		15	mV
TCV_{OSCM}	Common Mode Offset Voltage Drift		●		3		$\mu\text{V}/^\circ\text{C}$
$I_{V_{OCM}}$	V_{OCM} Input Current		●		5	15	μA
ENABLE Pin							
V_{IL}	ENABLE Input Low Voltage		●			0.8	V
V_{IH}	ENABLE Input High Voltage		●	2.4			V
I_{IL}	ENABLE Input Low Current	$ENABLE = 0.8\text{V}$	●			0.5	μA
I_{IH}	ENABLE Input High Current	$ENABLE = 2.4\text{V}$	●		1.4	3	μA
Power Supply							
V_S	Operating Supply Range		●	2.85	3	3.5	V
I_S	Supply Current	$ENABLE = 0.8\text{V}$	●	70	85	102	mA
I_{SHDN}	Shutdown Supply Current	$ENABLE = 2.4\text{V}$ Both Inputs and Outputs Floating	●		0.8	3	mA
PSRR	Power Supply Rejection Ratio (Differential Outputs)	2.85V to 3.5V	●	65	96		dB

AC ELECTRICAL CHARACTERISTICSSpecifications are at $T_A = 25^\circ\text{C}$. $V^+ = 3\text{V}$, $V^- = 0\text{V}$, $V_{\text{OCM}} = 1.25\text{V}$,ENABLE = 0V, No R_L unless otherwise noted.

SYMBOL	PARAMETER	CONDITIONS	MIN	TYP	MAX	UNITS
-3dB BW	-3dB Bandwidth	200mV _{P-P,OUT} (Note 6)	1.2	1.9		GHz
0.5dB BW	Bandwidth for 0.5dB Flatness	200mV _{P-P,OUT} (Note 6)		0.53		GHz
0.1dB BW	Bandwidth for 0.1dB Flatness	200mV _{P-P,OUT} (Note 6)		0.28		GHz
1/f	1/f Noise Corner			13.9		kHz
SR	Slew Rate	Differential $V_{\text{OUT}} = 2\text{V}$ Step (Note 6)		6670		V/ μs
$t_{S1\%}$	1% Settling Time	$V_{\text{OUT}} = 2V_{P-P}$ (Note 6)		2		ns
t_{OVR}	Overdrive Recovery Time	$V_{\text{OUT}} = 1.9V_{P-P}$ (Note 6)		16		ns
t_{ON}	Turn-On Time	+OUT, -OUT Within 10% of Final Values		120		ns
t_{OFF}	Turn-Off Time	I_{CC} Falls to 10% of Nominal		166		ns
-3dB BW _{VOCM}	V_{OCM} Pin Small Signal -3dB BW	0.1V _{P-P} at V_{OCM} , Measured Single-Ended at Output (Note 6)		14.7		MHz

10MHz Input Signal

HD2,10M/HD3,10M	Second/Third Order Harmonic Distortion	2V _{P-P,OUT} , $R_L = 200\Omega$	-99/-90	dBc
		2V _{P-P,OUT} , No R_L	-98/-99	dBc
IMD3,10M	Third-Order Intermodulation (f1 = 9.5MHz f2 = 10.5MHz)	2V _{P-P,OUT} Composite, $R_L = 200\Omega$	-91	dBc
		2V _{P-P,OUT} Composite, No R_L	-93	dBc
OIP3,10M	Equivalent Third-Order Output Intercept Point (f1 = 9.5MHz f2 = 10.5MHz)	2V _{P-P,OUT} Composite, No R_L (Note 7)	50.5	dBm
P _{1dB,10M}	1dB Compression Point	$R_L = 375\Omega$ (Notes 5, 7)	17.8	dBm
NF _{10M}	Noise Figure	$R_L = 375\Omega$ (Note 5)	6.8	dB
$e_{\text{IN},10\text{M}}$	Input Referred Voltage Noise Density	Includes Resistors (Short Inputs)	1.5	nV/ $\sqrt{\text{Hz}}$
$e_{\text{ON},10\text{M}}$	Output Referred Voltage Noise Density	Includes Resistors (Short Inputs)	30	nV/ $\sqrt{\text{Hz}}$

70MHz Input Signal

HD2,70M/HD3,70M	Second/Third Order Harmonic Distortion	2V _{P-P,OUT} , $R_L = 200\Omega$	-87/-81	dBc
		2V _{P-P,OUT} , No R_L	-87/-94	dBc
IMD3,70M	Third-Order Intermodulation (f1 = 69.5MHz f2 = 70.5MHz)	2V _{P-P,OUT} Composite, $R_L = 200\Omega$	-85	dBc
		2V _{P-P,OUT} Composite, No R_L	-94	dBc
OIP3,70M	Equivalent Third-Order Output Intercept Point (f1 = 69.5MHz f2 = 70.5MHz)	2V _{P-P,OUT} Composite, No R_L (Note 7)	51	dBm
P _{1dB,70M}	1dB Compression Point	$R_L = 375\Omega$ (Notes 5, 7)	18.2	dBm
NF _{70M}	Noise Figure	$R_L = 375\Omega$ (Note 5)	6.7	dB
$e_{\text{IN},70\text{M}}$	Input Referred Voltage Noise Density	Includes Resistors (Short Inputs)	1.4	nV/ $\sqrt{\text{Hz}}$
$e_{\text{ON},70\text{M}}$	Output Referred Voltage Noise Density	Includes Resistors (Short Inputs)	28	nV/ $\sqrt{\text{Hz}}$

140MHz Input Signal

HD2,140M/HD3,140M	Second/Third Order Harmonic Distortion	2V _{P-P,OUT} , $R_L = 200\Omega$	-83/-72	dBc
		2V _{P-P,OUT} , No R_L	-81/-83	dBc
IMD3,140M	Third-Order Intermodulation (f1 = 139.5MHz f2 = 140.5MHz)	2V _{P-P,OUT} Composite, $R_L = 200\Omega$	-80	dBc
		2V _{P-P,OUT} Composite, No R_L	-88	dBc
OIP3,140M	Equivalent Third-Order Output Intercept Point (f1 = 139.5MHz f2 = 140.5MHz)	2V _{P-P,OUT} Composite, No R_L (Note 7)	48	dBm

640026fa

AC ELECTRICAL CHARACTERISTICSSpecifications are at $T_A = 25^\circ\text{C}$. $V^+ = 3\text{V}$, $V^- = 0\text{V}$, $V_{\text{OCM}} = 1.25\text{V}$,ENABLE = 0V, No R_L unless otherwise noted.

SYMBOL	PARAMETER	CONDITIONS	MIN	TYP	MAX	UNITS
$P_{1\text{dB},140\text{M}}$	1dB Compression Point	$R_L = 375\Omega$ (Notes 5, 7)		18.7		dBm
$NF_{140\text{M}}$	Noise Figure	$R_L = 375\Omega$ (Note 5)		6.6		dB
$e_{N,140\text{M}}$	Input Referred Voltage Noise Density	Includes Resistors (Short Inputs)		1.4		$\text{nV}/\sqrt{\text{Hz}}$
$e_{\text{ON},140\text{M}}$	Output Referred Voltage Noise Density	Includes Resistors (Short Inputs)		28		$\text{nV}/\sqrt{\text{Hz}}$
240MHz Input Signal						
$HD_{2,240\text{M}}/HD_{3,240\text{M}}$	Second/Third Order Harmonic Distortion	$2V_{\text{P-P,OUT}}$, $R_L = 200\Omega$		-70/-59		dBc
		$2V_{\text{P-P,OUT}}$, No R_L		-75/-71		dBc
$IMD_{3,240\text{M}}$	Third Order Intermodulation ($f_1 = 239.5\text{MHz}$ $f_2 = 240.5\text{MHz}$)	$2V_{\text{P-P,OUT}}$ Composite, $R_L = 200\Omega$		-70		dBc
		$2V_{\text{P-P,OUT}}$ Composite, No R_L		-76		dBc
$OIP_{3,240\text{M}}$	Third Order Output Intercept Point ($f_1 = 239.5\text{MHz}$ $f_2 = 240.5\text{MHz}$)	$2V_{\text{P-P,OUT}}$ Composite, No R_L (Note 7)		42		dBm
$P_{1\text{dB},240\text{M}}$	1dB Compression Point	$R_L = 375\Omega$ (Notes 5, 7)		18.1		dBm
$NF_{240\text{M}}$	Noise Figure	$R_L = 375\Omega$ (Note 5)		6.9		dB
$e_{N,240\text{M}}$	Input Referred Voltage Noise Density	Includes Resistors (Short Inputs)		1.4		$\text{nV}/\sqrt{\text{Hz}}$
$e_{\text{ON},240\text{M}}$	Output Referred Voltage Noise Density	Includes Resistors (Short Inputs)		28		$\text{nV}/\sqrt{\text{Hz}}$
300MHz Input Signal						
$HD_{2,300\text{M}}/HD_{3,300\text{M}}$	Second/Third Order Harmonic Distortion	$2V_{\text{P-P,OUT}}$, $R_L = 200\Omega$		-66/-54		dBc
		$2V_{\text{P-P,OUT}}$, No R_L		-76/-62		dBc
$IMD_{3,300\text{M}}$	Third Order Intermodulation ($f_1 = 299.5\text{MHz}$ $f_2 = 300.5\text{MHz}$)	$2V_{\text{P-P,OUT}}$ Composite, $R_L = 200\Omega$		-66		dBc
		$2V_{\text{P-P,OUT}}$ Composite, No R_L		-71		dBc
$OIP_{3,300\text{M}}$	Equivalent Third Order Output Intercept Point ($f_1 = 299.5\text{MHz}$ $f_2 = 300.5\text{MHz}$)	$2V_{\text{P-P,OUT}}$ Composite, No R_L (Note 7)		39.5		dBm
$P_{1\text{dB},300\text{M}}$	1dB Compression Point	$R_L = 375\Omega$ (Notes 5, 7)		17.7		dBm
$NF_{300\text{M}}$	Noise Figure	$R_L = 375\Omega$ (Note 5)		7.6		dB
$e_{N,300\text{M}}$	Input Referred Voltage Noise Density	Includes Resistors (Short Inputs)		1.5		$\text{nV}/\sqrt{\text{Hz}}$
$e_{\text{ON},300\text{M}}$	Output Referred Voltage Noise Density	Includes Resistors (Short Inputs)		30		$\text{nV}/\sqrt{\text{Hz}}$
$IMD_{3,280\text{M}/320\text{M}}$	Third Order Intermodulation ($f_1 = 280\text{MHz}$ $f_2 = 320\text{MHz}$) Measured at 360MHz	$2V_{\text{P-P,OUT}}$ Composite, $R_L = 375\Omega$		-68	-62	dBc

Note 1: Stresses beyond those listed under Absolute Maximum Ratings may cause permanent damage to the device. Exposure to any Absolute Maximum Rating condition for extended periods may affect device reliability and lifetime.

Note 2: Input pins (+IN, -IN) are protected by steering diodes to either supply. If the inputs go beyond either supply rail, the input current should be limited to less than 10mA.

Note 3: The LTC6400C is guaranteed functional over the operating temperature range of -40°C to 85°C .

Note 4: The LTC6400C is guaranteed to meet specified performance from 0°C to 70°C . It is designed, characterized and expected to meet specified

performance from -40°C to 85°C but is not tested or QA sampled at these temperatures. The LTC6400I is guaranteed to meet specified performance from -40°C to 85°C .

Note 5: Input and output baluns used. See Test Circuit A.

Note 6: Measured using Test Circuit B. $R_L = 87.5\Omega$ per output.

Note 7: Since the LTC6400-26 is a feedback amplifier with low output impedance, a resistive load is not required when driving an AD converter. Therefore, typical output power is very small. In order to compare the LTC6400-26 with amplifiers that require 50Ω output load, the LTC6400-26 output voltage swing driving a given R_L is converted to OIP_3 and $P_{1\text{dB}}$ as if it were driving a 50Ω load. Using this modified convention, $2V_{\text{P-P}}$ is by definition equal to 10dBm, regardless of actual R_L .

TYPICAL PERFORMANCE CHARACTERISTICS

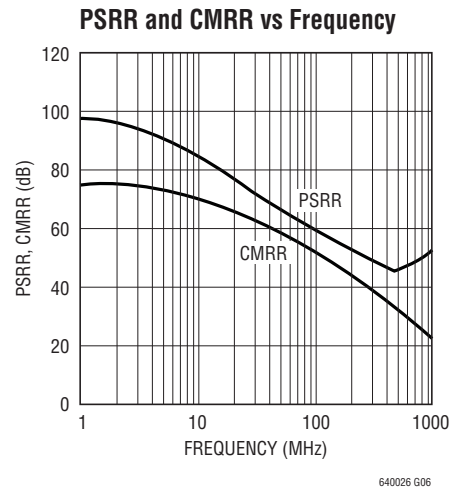
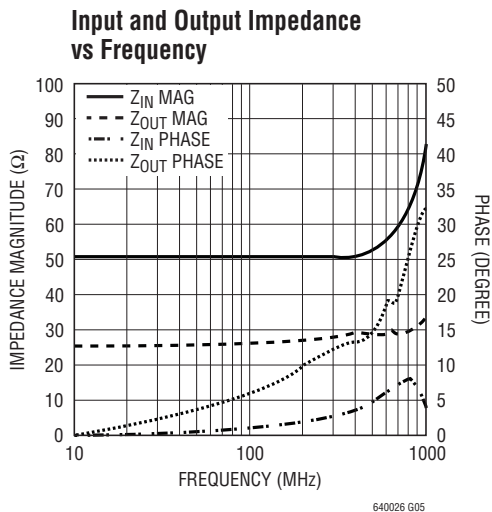
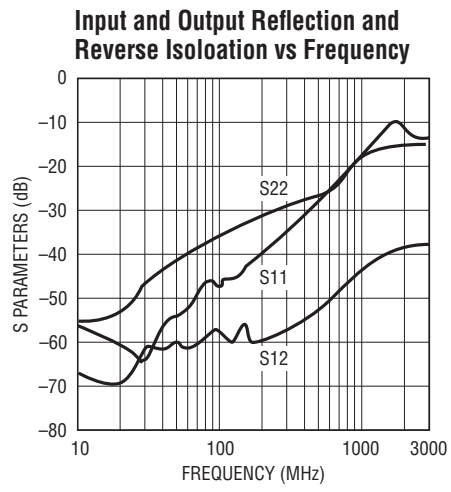
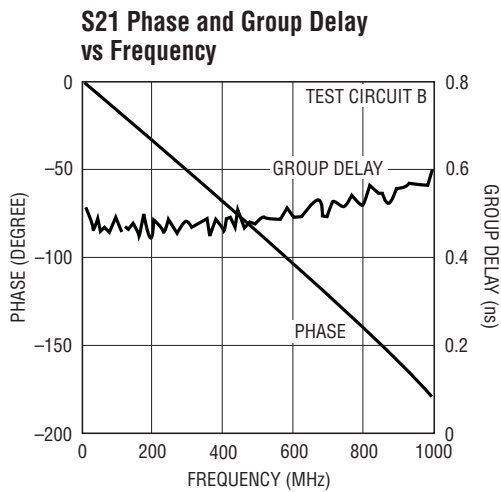
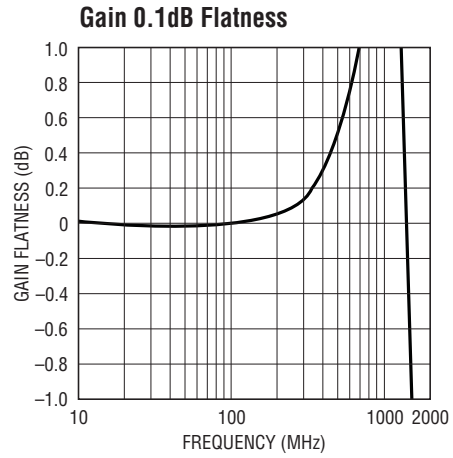
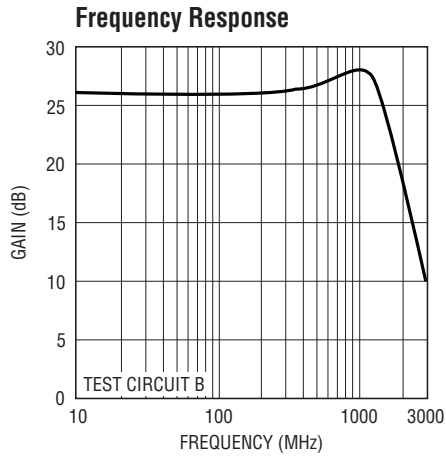

TYPICAL PERFORMANCE CHARACTERISTICS

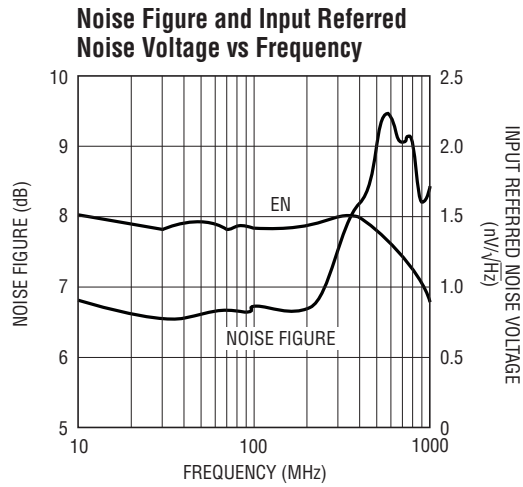

640026 G07

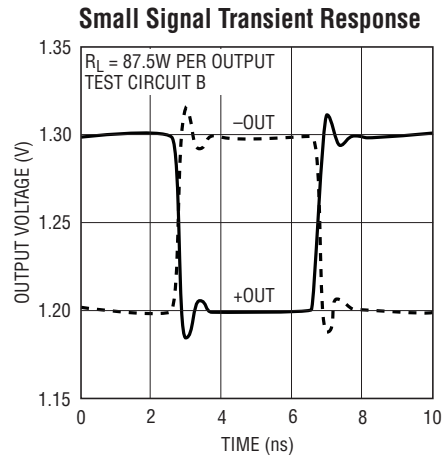

640026 G08

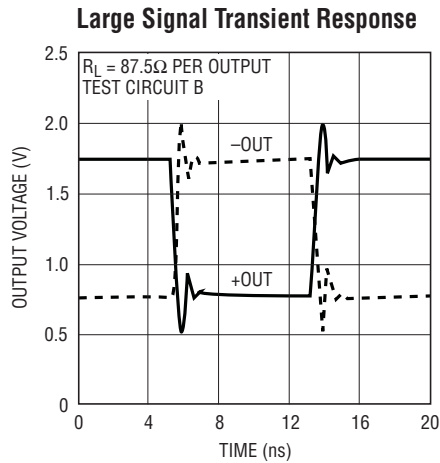

640026 G09

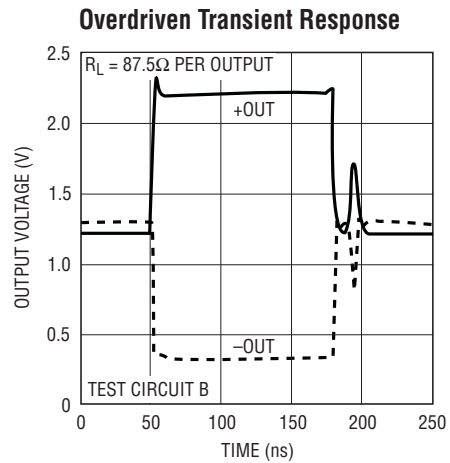

640026 G10

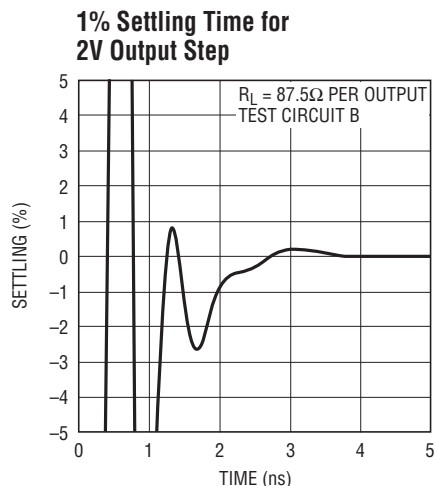

640026 G11

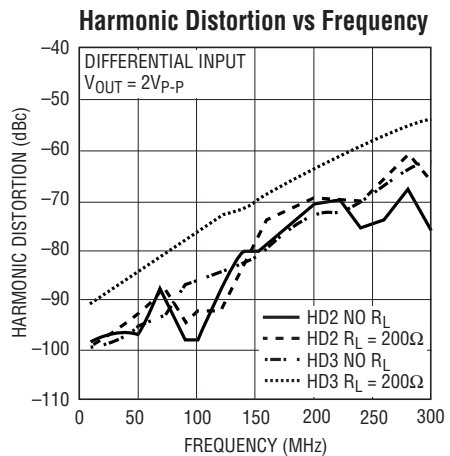

640026 G12

TYPICAL PERFORMANCE CHARACTERISTICS

Third Order Intermodulation Distortion vs Frequency

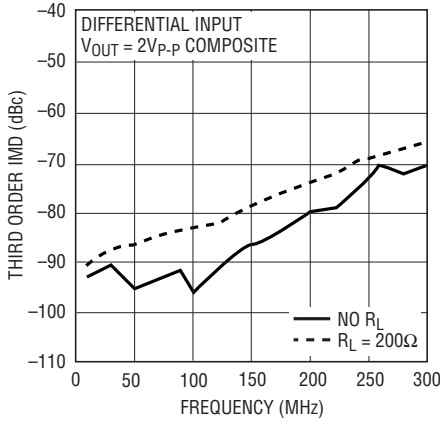

640026 G13

Harmonic Distortion vs Frequency

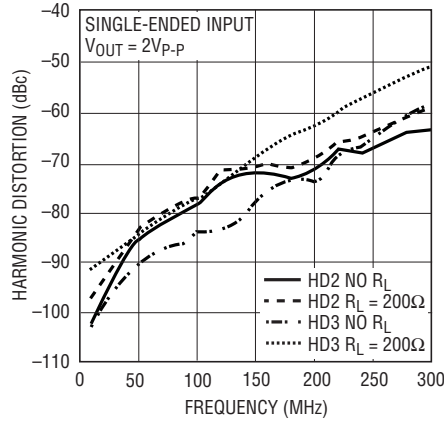

640026 G14

Third Order Intermodulation Distortion vs Frequency

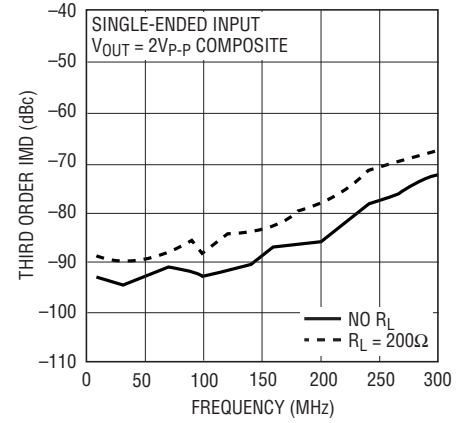

640026 G15

Output 1dB Compression Point vs Frequency

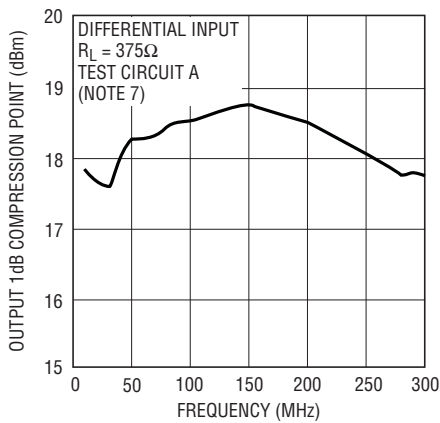

640026 G16

Equivalent Output Third Order Intercept Point vs Frequency

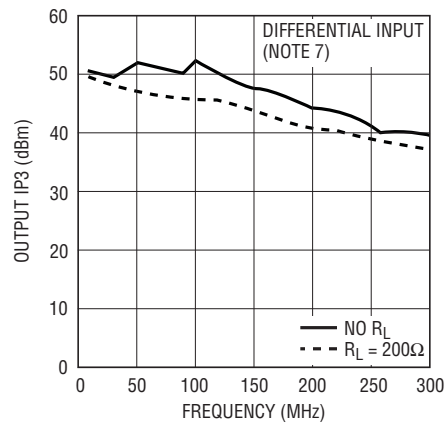

640026 G17

Turn-On Time

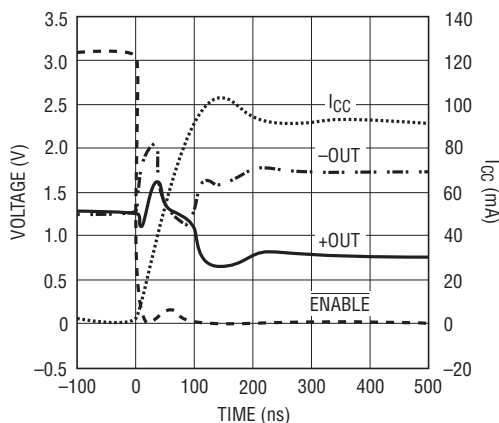

640026 G18

Turn-Off Time

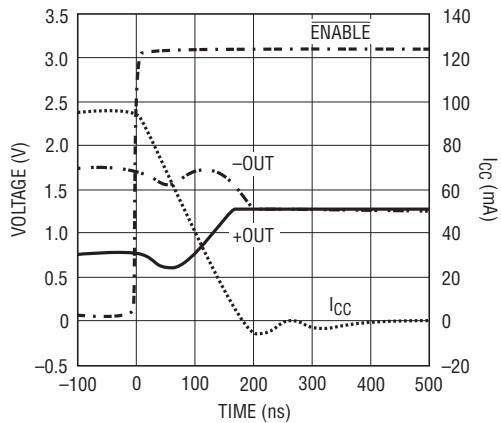

640026 G19

PIN FUNCTIONS

V⁺ (Pins 1, 3, 10): Positive Power Supply (Normally tied to 3V or 3.3V). All three pins must be tied to the same voltage. Bypass each pin with 1000pF and 0.1μF capacitors as close to the pins as possible.

V_{OCM} (Pin 2): This pin sets the output common mode voltage. An 0.1μF external bypass capacitor is recommended.

V⁻ (Pins 4, 9, 12, 17): Negative Power Supply. All four pins must be connected to same voltage/ground.

-OUT, +OUT (Pins 5, 8): Unfiltered Outputs. These pins have series 12.5Ω resistors R_{OUT}.

-OUTF, +OUTF (Pins 6, 7): Filtered Outputs. These pins have 50Ω series resistors and a 2.7pF shunt capacitor.

ENABLE (Pin 11): This pin is a logic input referenced to V_{EE}. If low, the part is enabled. If high, the part is disabled and draws very low standby current while the internal op amp has high output impedance.

+IN (Pins 13, 14): Positive Input. Pins 13 and 14 are internally shorted together.

-IN (Pins 15, 16): Negative Input. Pins 15 and 16 are internally shorted together.

Exposed Pad (Pin 17): V⁻. The Exposed Pad must be connected to same voltage/ground as pins 4, 9, 12.

BLOCK DIAGRAM

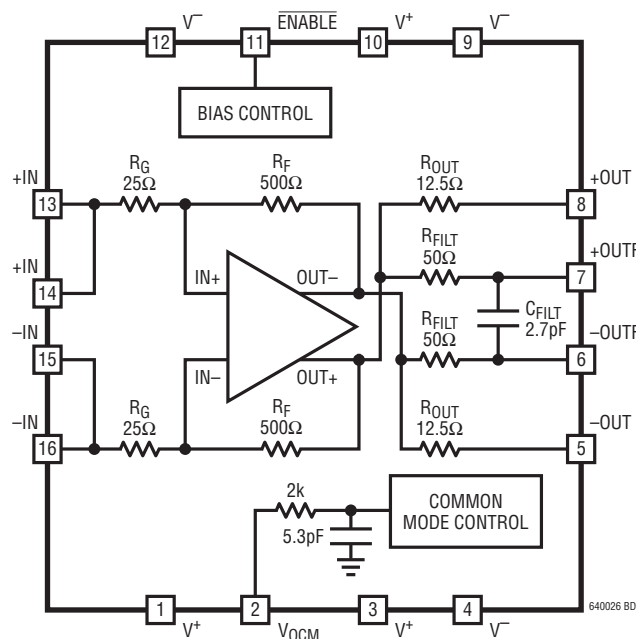

APPLICATIONS INFORMATION

Circuit Operation

The LTC6400-26 is a low noise and low distortion fully differential op amp/ADC driver with:

- Operation from DC to 1.9GHz –3dB bandwidth
- Fixed gain of 20V/V (26dB)
- Differential input impedance 50Ω
- Differential output impedance 25Ω
- Differential impedance of output filter 100Ω

The LTC6400-26 is composed of a fully differential amplifier with on chip feedback and output common mode voltage control circuitry. Differential gain and input impedance are set by 25Ω/500Ω resistors in the feedback network. Small output resistors of 12.5Ω improve the circuit stability over various load conditions. They also provide a possible external filtering option, which is often desirable when the load is an ADC.

Filter resistors of 50Ω are available for additional filtering. Lowpass/bandpass filters are easily implemented with just a couple of external components. Moreover, they offer single-ended 50Ω matching in wideband applications and no external resistor is needed.

The LTC6400-26 is very flexible in terms of I/O coupling. It can be AC- or DC-coupled at the inputs, the outputs or both. Due to the internal connection between input and output, users are advised to keep input common mode voltage between 1V and 1.6V for proper operation. If the inputs are AC-coupled, the input common mode voltage is automatically biased close to V_{OCM} and thus no external circuitry is needed for bias. The LTC6400-26 provides an output common mode voltage set by V_{OCM} , which allows driving ADC directly without external components such as transformer or AC coupling capacitors. The input signal can be either single-ended or differential with only minor difference in distortion performance.

Input Impedance and Matching

The differential input impedance of the LTC6400-26 is 50Ω. The interface between the input of LTC6400-26 and 50Ω source is straightforward. One way is to directly connect

them if the source is differential (Figure 1). Another approach is to employ a wideband transformer if the source is single ended (Figure 2). Both methods provide a wideband match. The transformer must be placed close to the input pins in order to minimize the reflection due to input mismatch. Alternatively, one could apply a narrowband impedance match at the inputs of the LTC6400-26 for frequency selection and/or noise reduction.

Referring to Figure 3, LTC6400-26 can be easily configured for single-ended input and differential output without a balun. The signal is fed to one of the inputs through a matching network while the other input is connected to the same matching network and a source resistor. Because the return ratios of the two feedback paths are equal, the two outputs have the same gain and thus symmetrical swing. In general, the single-ended input impedance and termination resistor R_T are determined by the combination of R_S , R_G and R_F . For example, when R_S is 50Ω, it is found that the single-ended input impedance is 75Ω and R_T is 150Ω in order to match to a 50Ω source impedance.

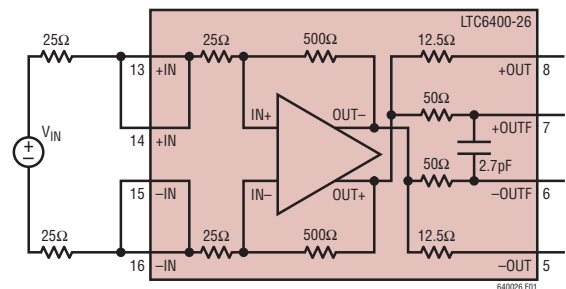

Figure 1. Input Termination for Differential 50Ω Input Impedance

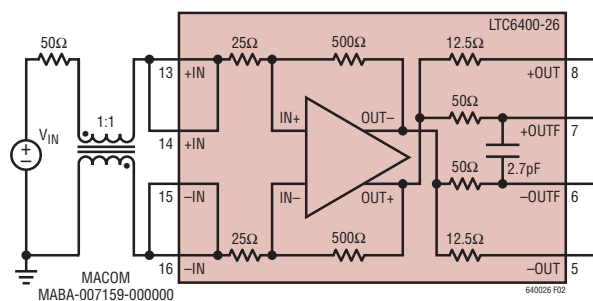

Figure 2. Input Termination for Differential 50Ω Input Impedance Using a Balun

APPLICATIONS INFORMATION

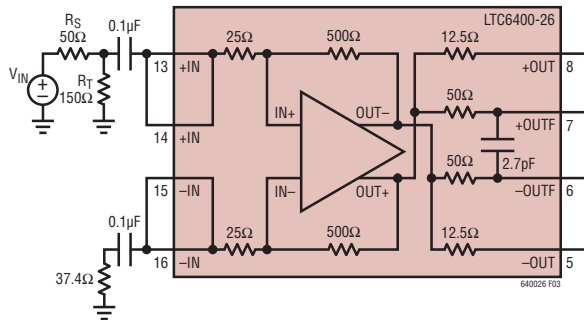

Figure 3. Input Termination for Single-Ended 50Ω Input Impedance

The LTC6400-26 is unconditionally stable, i.e. differential stability factor $K_f > 1$ and stability measure $B1 > 0$. However, the overall differential gain is affected by both source impedance and load impedance as shown in Figure 4:

$$A_V = \left| \frac{V_{OUT}}{V_{IN}} \right| = \frac{1000}{R_S + 50} \cdot \frac{R_L}{25 + R_L}$$

The noise performance of the LTC6400-26 also depends upon the source impedance and termination. A trade-off between gain and noise is obvious when constant noise figure circle and constant gain circle are plotted within the same input Smith Chart, based on which users can choose the optimal source impedance for a given gain and noise requirement.

Output Impedance Match and Filter

The LTC6400-26 can drive an ADC directly without external output impedance matching. Alternatively, the differential output impedance of 25Ω can be made larger, e.g. 50Ω, by series resistors or LC network.

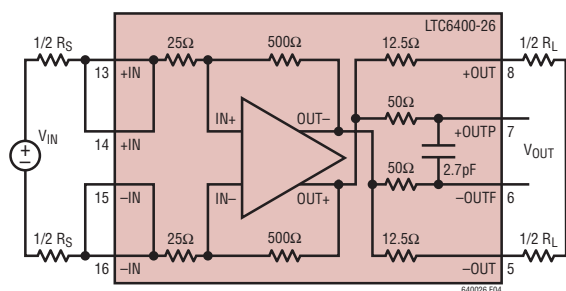

Figure 4. Calculate Differential Gain

The internal low pass filter outputs at +OUTF/-OUTF have a -3dB bandwidth of 590MHz. External capacitor can reduce the low pass filter bandwidth as shown in Figure 5. A bandpass filter is easily implemented with only a few components as shown in Figure 6. Three 39pF capacitors and a 16nH inductor create a bandpass filter with 165MHz center frequency, -3dB frequencies at 138MHz and 200MHz.

Output Common Mode Adjustment

The LTC6400-26's output common mode voltage is set by the V_{OCM} pin, which is a high impedance input. The output common mode voltage is capable of tracking V_{OCM} in a range from 1V to 1.6V. Bandwidth of V_{OCM} control is typically 15MHz, which is dominated by a low pass filter connected to the V_{OCM} pin and is aimed to reduce common mode noise generation at the outputs. The internal common mode feedback loop has a -3dB bandwidth of 400MHz, allowing fast rejection of any common mode output disturbance. The V_{OCM} pin should be tied to a DC bias voltage with a 0.1μF bypass capacitor. When interfacing with A/D converters such as the LTC22xx families, the V_{OCM} pin can be connected to the V_{CM} pin of the ADC.

Driving A/D Converters

The LTC6400-26 has been specifically designed to interface directly with high speed A/D converters. Figure 7 shows the LTC6400-26 with a single-ended input driving the LTC2208, which is a 16-bit, 130MSPS ADC. Two external 5Ω resistors help eliminate potential resonance associated with bond wires of either the ADC input or the driver output. V_{OCM} of the LTC6400-26 is connected to V_{CM} of the LTC2208 at 1.25V. Alternatively, a single-ended input signal can be

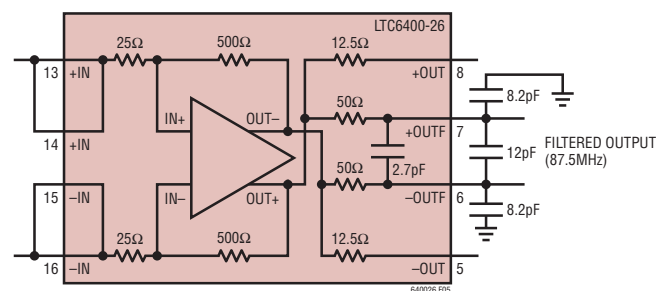

Figure 5. LTC6400-26 Internal Filter Topology Modified for Low Filter Bandwidth (Three External Capacitors)

APPLICATIONS INFORMATION

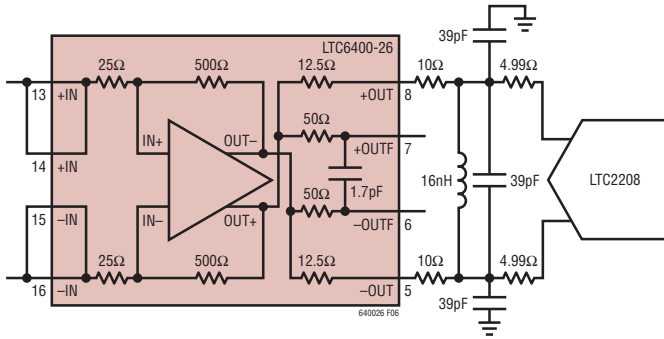

Figure 6. LTC6400-26 with 165MHz Output Bandpass Filter

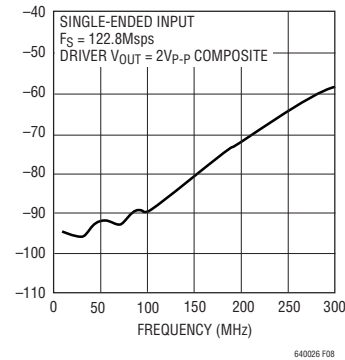

Figure 8. IMD_3 for the Combination of LTC6400-26 and LTC2208

converted to a differential signal via a balun and fed to the input of the LTC6400-26. Figure 8 summarizes the IMD_3 performance of the whole system in Figure 7.

Test Circuits

Due to the fully-differential design of the LTC6400 and its usefulness in applications with differing characteristic specifications, two test circuits are used to generate the information in this datasheet. Test Circuit A is DC987B, a two-port demonstration circuit for the LTC6400 family. The silkscreen is shown in Figure 9. This circuit includes input and output transformers (baluns) for single-ended-to-differential conversion and impedance transformation, allowing direct hook-up to a 2-port network analyzer. There are also series resistors at the output to present the LTC6400 with a 375Ω differential load, optimizing distortion performance. Due to the input and output transformers, the $-3dB$ bandwidth is reduced from 1.9GHz to 1.67GHz.

Test Circuit B uses a 4-port network analyzer to measure S-parameters and gain/phase response. This removes the effects of the wideband baluns and associated circuitry, for a true picture of the $>1GHz$ S-parameters and AC characteristics.

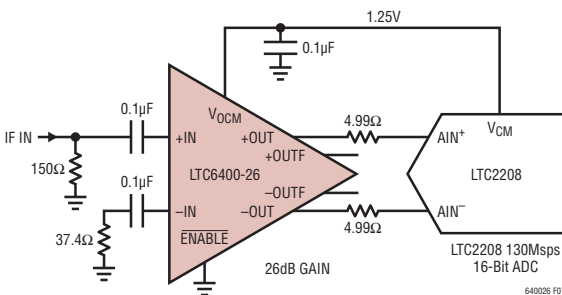

Figure 7. Single-Ended Input to LTC6400-26 and LTC2208

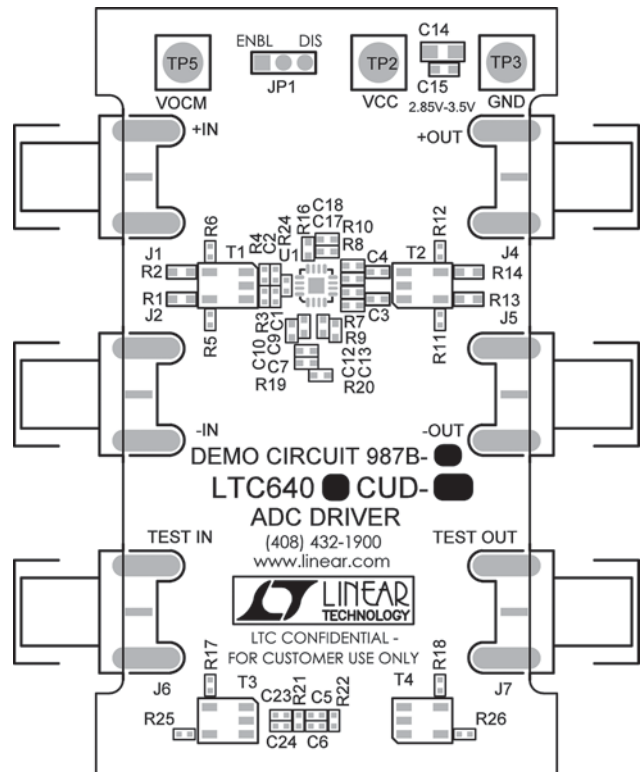
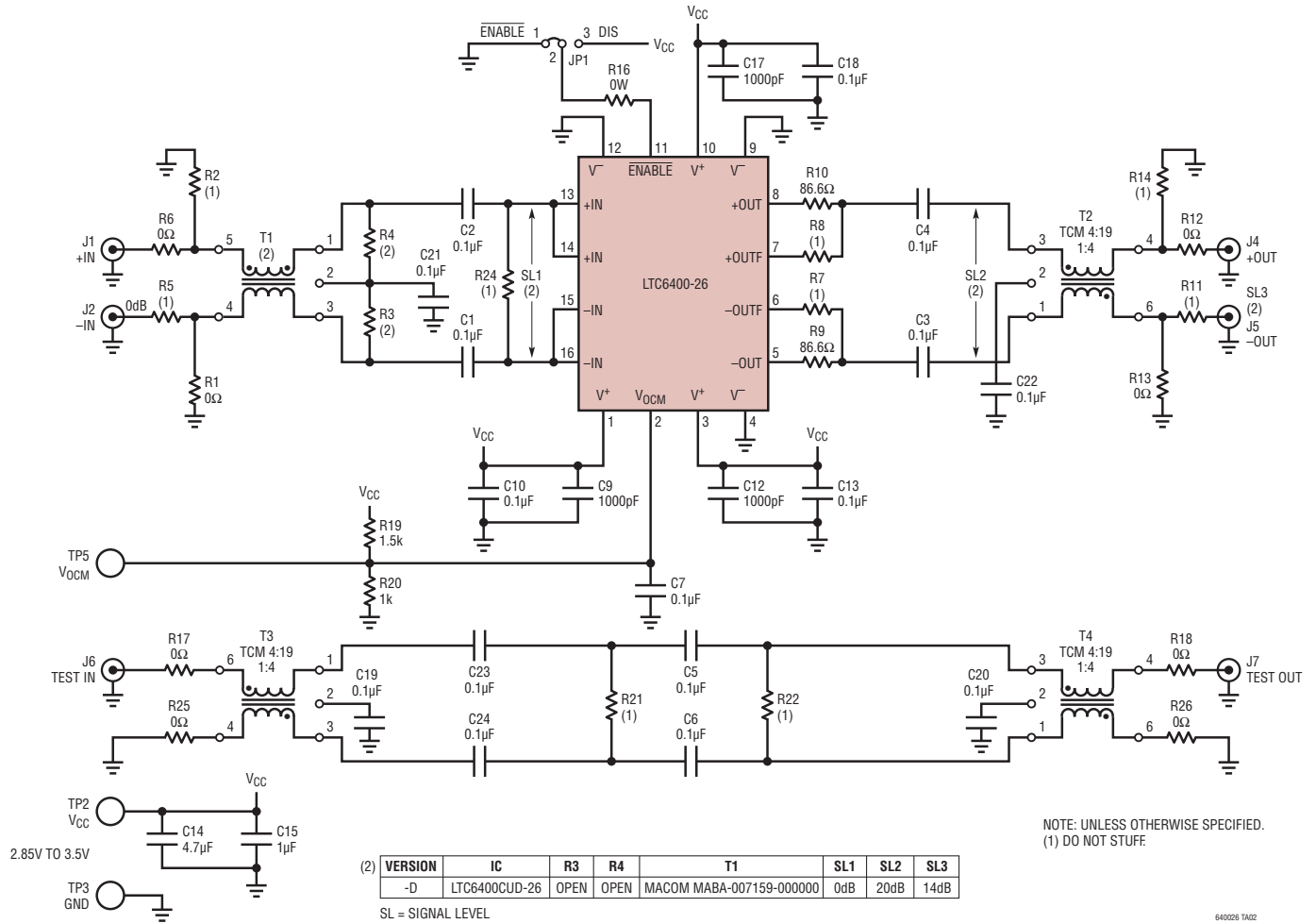

Figure 9. Top Silkscreen of DC987B, Test Circuit A

TYPICAL APPLICATION

Demo Circuit 987B Schematic (Test Circuit A)



TYPICAL APPLICATIONS

Test Circuit B, 4-Port Analysis

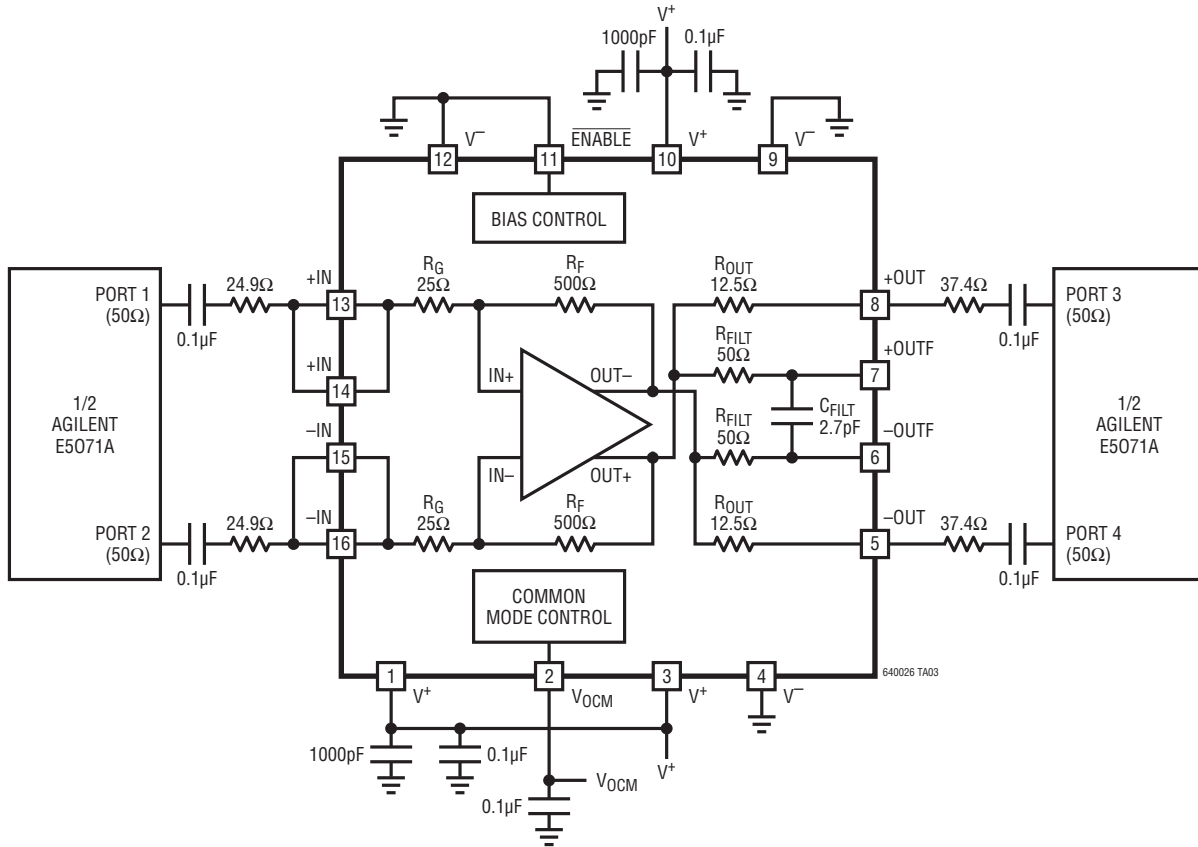

Optical Photodiode Receiver

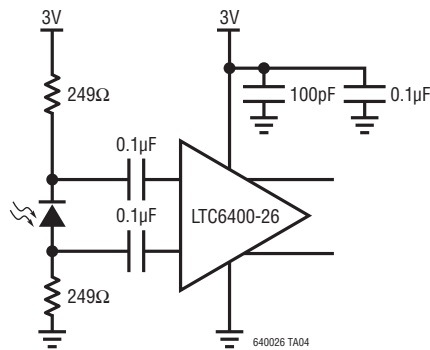

PD: JDSU ETX 100RFC2
 -3dB BW: 1.1GHz
 RISE TIME: 200ps

PACKAGE DESCRIPTION

UD Package 16-Lead Plastic QFN (3mm × 3mm) (Reference LTC DWG # 05-08-1691)

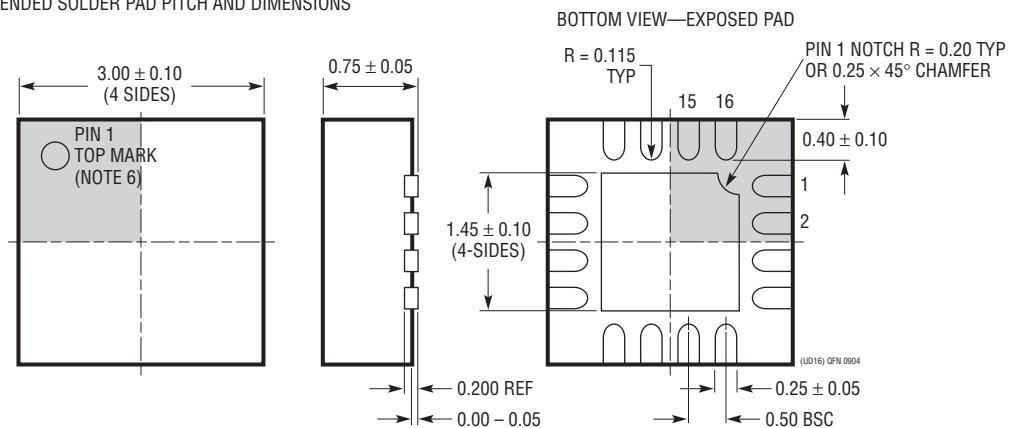
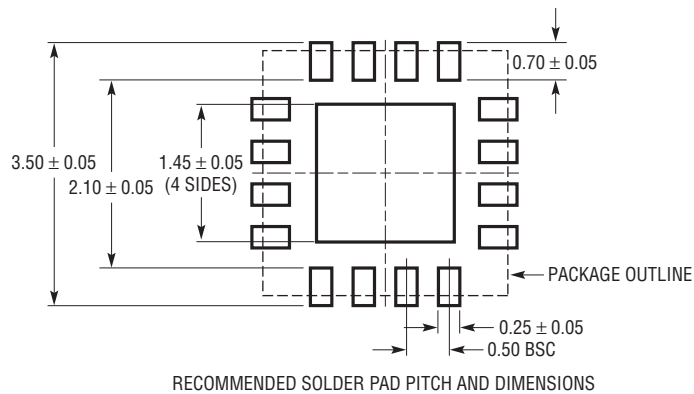

NOTE:

1. DRAWING CONFORMS TO JEDEC PACKAGE OUTLINE MO-220 VARIATION (WEED-2)
2. DRAWING NOT TO SCALE
3. ALL DIMENSIONS ARE IN MILLIMETERS
4. DIMENSIONS OF EXPOSED PAD ON BOTTOM OF PACKAGE DO NOT INCLUDE MOLD FLASH. MOLD FLASH, IF PRESENT, SHALL NOT EXCEED 0.15mm ON ANY SIDE
5. EXPOSED PAD SHALL BE SOLDER PLATED
6. SHADED AREA IS ONLY A REFERENCE FOR PIN 1 LOCATION ON THE TOP AND BOTTOM OF PACKAGE