

DCNEVT500 SERIES HIGH CURRENT HIGH VOLTAGE DC CONTACTOR RELAY



Description

High current and high voltage DC contactor relays for electric vehicle, hybrid electric vehicle, circuit protection, battery switch disconnect, and main transfer switch. The Coil Economizer greatly reduces coil power and heating after the contactor is energized. Once the contactor is energized, it takes minimal coil power to keep the contacts closed due to Pulse Width Modulation (PWM) reducing the average power delivered by pulsing the electrical signal. Utilizes polarized contacts for optimum performance amidst polarized electrical loads.

Features and Benefits

- High current (500A) and high voltage (1800V) contactor for EV applications
- Dual Coil Economizer greatly reduces coil power and heating
- Hermetically sealed contact chamber to protect all moving parts
- Optional auxiliary contacts available
- 360KW power switch capable
- Designed and manufactured under the IATF16949 certification for Automotive Quality Systems.
- Designed specifically for automotive applications.

Specifications Overview

Amperage:	500A Continuous Carry
Housing:	Nylon UL 94-V0
Voltage Rating:	1800V
Output Connectors:	M10
Ingress Protections:	IP54
Operating Temperature:	-40 to 85°C
Circuitry:	SPST NO
Coil Voltage:	B: 12V DC Nominal, 9.9 - 14V DC Working C: 24V DC Nominal, 19.7 - 28V DC Working
Max Coil Inrush Current:	B: 3.3A C: 1.7A
Size:	74mm x 54mm x 120mm
Mounting:	M5
Mounting Bolt Torque:	3-4 Nm (26-35 in-lb)
Contact Torque:	13 - 15 Nm (115- 130 in-lb)
Terminals:	M10 Silver Plated Copper
Coil Terminals:	M3.5 x 0.6
Approvals:	UL File No. E510407 Recognized

Applications

- Battery Electric Vehicles
- Hybrid Electric Vehicles
- Material Handling
- Electric Maintenance and Transport Vehicles
- Industrial Applications

Web Resources

Download 2D print and technical resources at:
littelfuse.com/DCNEVT500

Ordering Information

PART NUMBER	DESCRIPTION	COIL VOLTAGE 12V DC	COIL VOLTAGE 24V DC	BOTTOM MOUNT	AUXILIARY CONTACT SPST-NO
DCNEVT500-C	High Voltage DC Contactor Relay Bottom Mount with Polar Load Terminals		●	●	
DCNEVT500-CA	High Voltage DC Contactor Relay Bottom Mount with Auxiliary Circuit with Polar Load Terminals		●	●	●
DCNEVT500-BA	High Voltage DC Contactor Relay Bottom Mount with Auxiliary Circuit with Polar Load Terminals	●		●	●
DCNEVT500-B	High Voltage DC Contactor Relay Bottom Mount with Polar Load Terminals	●		●	

* Box Packaging Available

DCNEVT500 SERIES HIGH CURRENT HIGH VOLTAGE DC CONTACTOR RELAY

Dimensions in MM

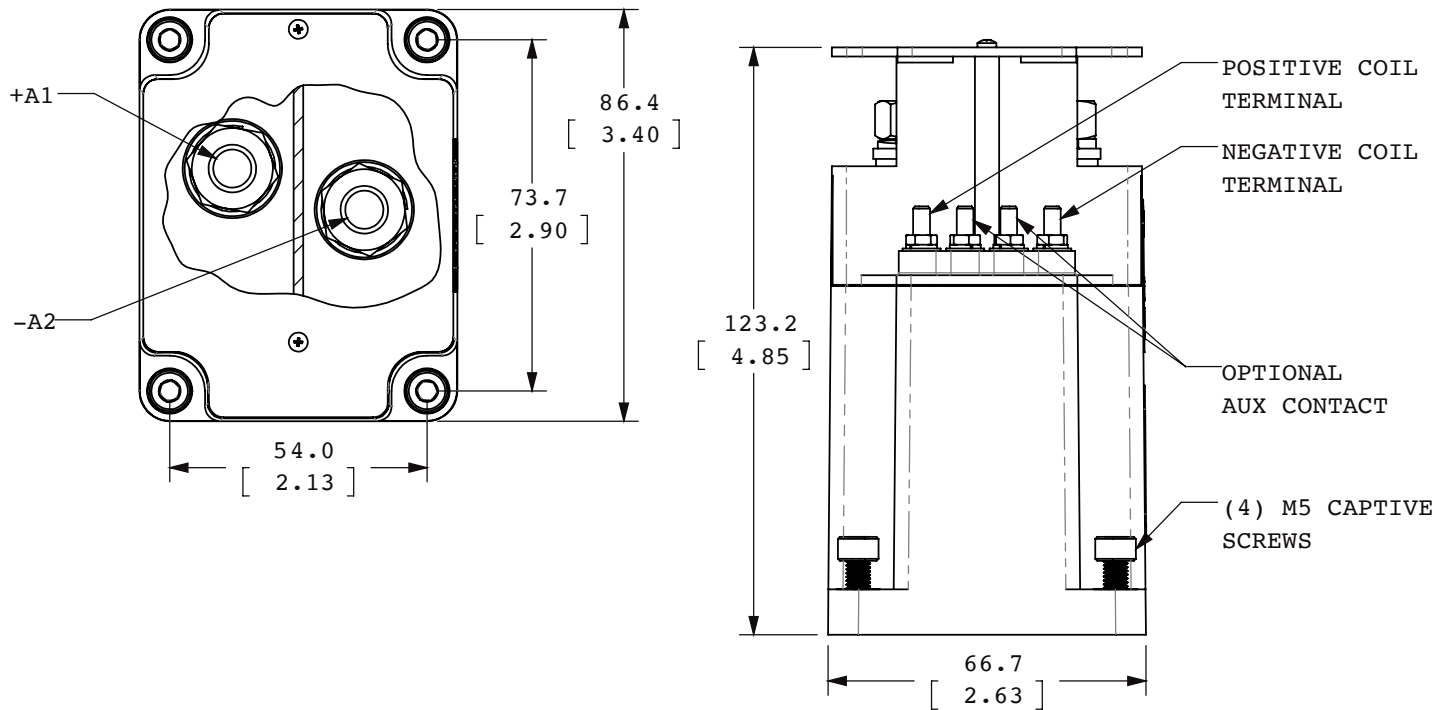

Estimated Make Break Chart

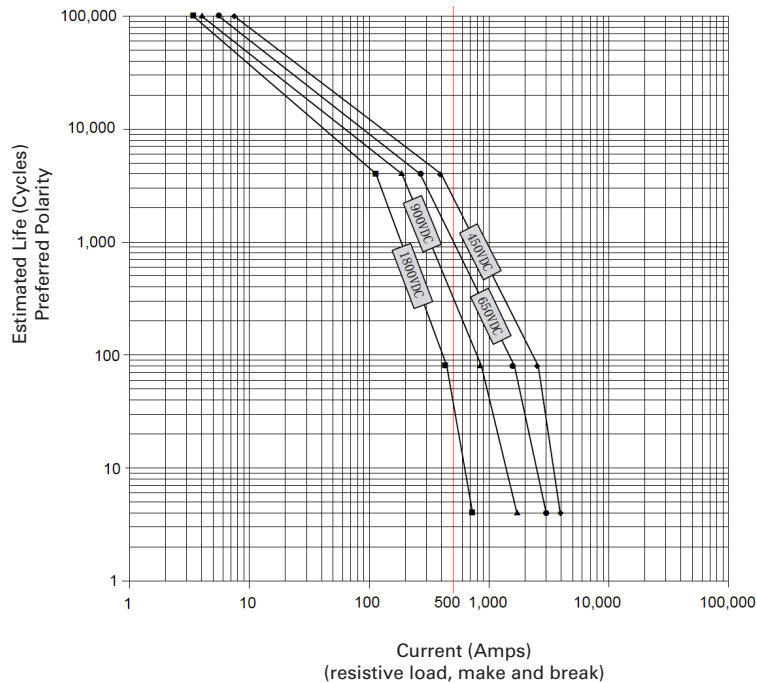

Electrical Diagram

