

DCNLEV100 SERIES HIGH CURRENT HIGH VOLTAGE DC CONTACTOR RELAY



Ordering Information

Please see page 2 for more information

Specifications Overview

Amperage:	100A Continuous Carry
Housing:	Nylon UL 94-V0
Voltage Rating:	750V
Output Connectors:	M5 Bolt and Lockwasher Connections
Connectors:	Wire Leads for Control Circuit
Ingress Protections:	IP67
Operating Temperature:	-40 to 85°C
Circuitry:	SPST NO
Coil Voltage:	B: 12V DC Nominal, 8-16V DC Working C: 24V DC Nominal, 16-28V DC Working E: 48V DC Nominal, 33-52V DC Working
Max Coil Inrush Current:	B: 461mA Max to Coil C: 250mA Max to Coil E: 122mA Max to Coil
Mounting:	M4 with Compression Limiters
Size:	46mm x 53mm x 53mm
Mounting Bolt Torque:	2.3 Nm (20 in-lb)
Contact Torque:	3.4 - 4.5 Nm (30 - 40 in-lb)
Terminals:	M5 Silver Plated Copper
Approvals:	UL File No. E510407 Recognized

Description

High current and high voltage DC contactor relays for electric vehicle applications such as battery power supply, charging pill, motor control, circuit insulation, circuit protection, and also safety devices for industrial machinery. Are available with polarized and non-polarized contacts to best suit electrical systems' polarity.

Features and Benefits

- High current (100A) and high voltage (750V) contactor for EV applications
- Compact structure, helping reduce noise when turned on
- Sealed IP67, gas-filled relay which mitigates arcing
- No mounting orientation restrictions
- Designed and manufactured under the IATF16949 certification for Automotive Quality Systems.
- Designed specifically for automotive applications.

Applications

- Battery Electric Vehicles
- Hybrid Electric Vehicles
- Material Handling
- Electric Maintenance and Transport Vehicles
- Industrial applications

Web Resources

Download 2D print and technical resources at:
littelfuse.com/DCNLEV100

DCNLEV100 SERIES HIGH CURRENT HIGH VOLTAGE DC CONTACTOR RELAY

Ordering Information

PART NUMBER	DESCRIPTION	COIL VOLTAGE 12V DC	COIL VOLTAGE 24V DC	COIL VOLTAGE 48V DC	AUXILIARY CONTACT SPST-NO	BOTTOM MOUNT	SIDE MOUNT	NON-POLARIZED TERMINALS
DCNLEV100-B	High Voltage DC Contactor Relay Bottom Mount with Polar Load Terminals	●				●		
DCNLEV100-BA	High Voltage DC Contactor Relay Bottom Mount with Auxiliary Circuit with Polar Load Terminals	●			●	●		
DCNLEV100-BAN	High Voltage DC Contactor Relay Bottom Mount with Auxiliary Circuit & Non-Polar Load Terminals	●			●	●		●
DCNLEV100-BAS	High Voltage DC Contactor Relay Side Mount with Auxiliary Circuit with Polar Load Terminals	●			●		●	
DCNLEV100-BASN	High Voltage DC Contactor Relay Side Mount with Auxiliary Circuit & Non-Polar Load Terminals	●			●		●	●
DCNLEV100-BN	High Voltage DC Contactor Relay Bottom Mount with Non-Polar Load Terminals	●				●		●
DCNLEV100-BS	High Voltage DC Contactor Relay Side Mount with Polar Load Terminals	●					●	
DCNLEV100-BSN	High Voltage DC Contactor Relay Side Mount with Non-Polar Load Terminals	●					●	●
DCNLEV100-C	High Voltage DC Contactor Relay Bottom Mount with Polar Load Terminals		●			●		
DCNLEV100-CA	High Voltage DC Contactor Relay Bottom Mount with Auxiliary Circuit with Polar Load Terminals		●		●	●		
DCNLEV100-CAN	High Voltage DC Contactor Relay Bottom Mount with Auxiliary Circuit & Non-Polar Load Terminals		●		●	●		●
DCNLEV100-CAS	High Voltage DC Contactor Relay Side Mount with Auxiliary Circuit with Polar Load Terminals		●		●		●	
DCNLEV100-CASN	High Voltage DC Contactor Relay Side Mount with Auxiliary Circuit & Non-Polar Load Terminals		●		●		●	●
DCNLEV100-CN	High Voltage DC Contactor Relay Bottom Mount with Non-Polar Load Terminals		●			●		●
DCNLEV100-CS	High Voltage DC Contactor Relay Side Mount with Polar Load Terminals		●				●	
DCNLEV100-CSN	High Voltage DC Contactor Relay Side Mount with Non-Polar Load Terminals		●				●	●
DCNLEV100-E	High Voltage DC Contactor Relay Bottom Mount with Polar Load Terminals			●		●		
DCNLEV100-EA	High Voltage DC Contactor Relay Bottom Mount with Auxiliary Circuit with Polar Load Terminals			●	●	●		
DCNLEV100-EAN	High Voltage DC Contactor Relay Bottom Mount with Auxiliary Circuit & Non-Polar Load Terminals			●	●	●		●
DCNLEV100-EAS	High Voltage DC Contactor Relay Side Mount with Auxiliary Circuit with Polar Load Terminals			●	●		●	
DCNLEV100-EASN	High Voltage DC Contactor Relay Side Mount with Auxiliary Circuit & Non-Polar Load Terminals			●	●		●	●
DCNLEV100-EN	High Voltage DC Contactor Relay Bottom Mount with Non-Polar Load Terminals			●		●		●
DCNLEV100-ES	High Voltage DC Contactor Relay Side Mount with Polar Load Terminals			●			●	
DCNLEV100-ESN	High Voltage DC Contactor Relay Side Mount with Non-Polar Load Terminals			●			●	●

* Box Packaging Available

DCNLEV100 SERIES HIGH CURRENT HIGH VOLTAGE DC CONTACTOR RELAY

Estimated Make Break Chart

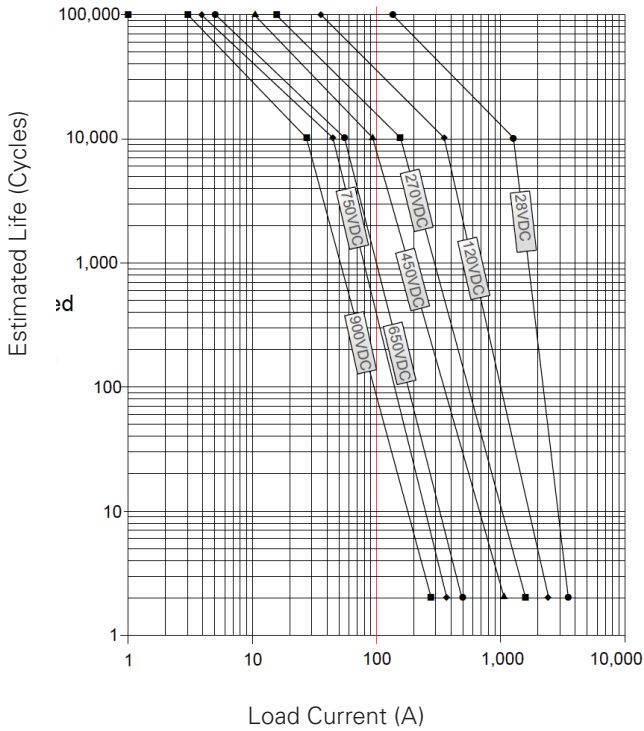

Electrical Diagram

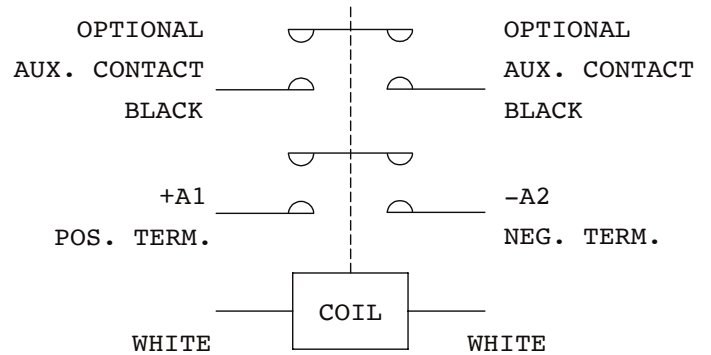

Dimensions in MM

Side Mount

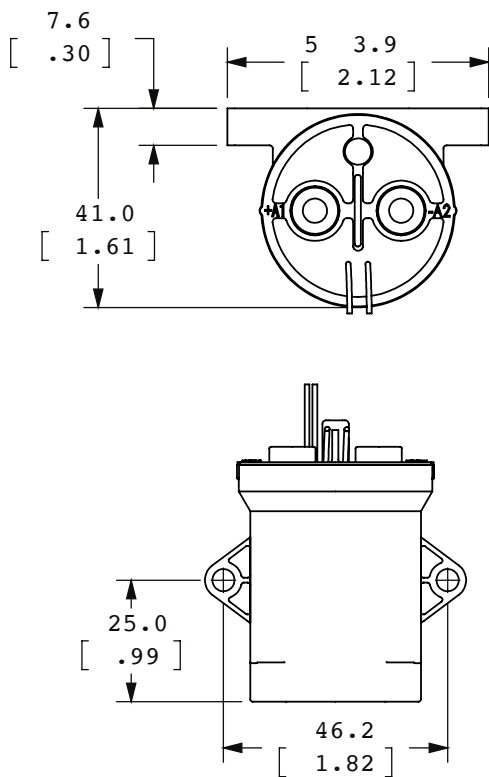

Bottom Mount

