

TLE7368E, TLE7368-2E and TLE7368-3E

Demoboard description

Switching Mode Power Supply (SMPS) OPTIREG™ TLE7368E, TLE7368-2E and TLE7368-3E

About this document

Scope and purpose

This user manual is intended provide information required to enable the reader to operate the TLE7368 PMIC family demo boards (TLE7368E, TLE7368-2E and TLE7368-3E) and to provide additional background information. However, the use of the datasheet and other application notes available for these products is expected.

Intended audience

This document is intended for power supply design engineers, application engineers, students and other persons, who need to design a power supply based on the TLE7368 PMIC family (TLE7368E, TLE7368-2E and TLE7368-3E).

The demoboard is intended to demonstate the performance of the TLE7368 PMIC family (TLE7368E, TLE7368-2E and TLE7368-3E) and to allow first testing and basic modification of components and application.

Note: The following information is given as a hint for the implementation of the device only and shall not be regarded as a description of warranty of a certain functionality, condition or quality to the device.

The application note is intended to provide important information about the usage of the device in the application and what to consider during hard- and software development.

This document is a compilation of important topica and hints, which have been collected during the product introduction. It does not cover all topics or features of the device.

Table of contents

About this document	1
Table of contents	2
1 Introduction	3
2 How to operate the demoboard	4
2.1 The demoboard.....	4
2.2 Quick start	4
2.3 Port description	5
3 Schematic	6
4 Part list	8
5 Layout	10
6 Additional information	13

1 Introduction

The TLE7368 PMIC family is a microcontroller power supply system using an asynchronous step-down converter as pre-regulator (operating with a fixed 370 kHz switching frequency) for optimizing the system efficiency. The pre-regulator supplies three LDOs and two trackers with different output voltages. The pre-regulator may also supply additional consumers if the total power consumption of the application (internal LDOs, trackers and external loads) does not exceed 2.5 A at any condition.

The nominal value of the pre-regulator output voltage is 5.5 V, but can be lower at input voltages between 6.3 V and the minimum allowed input voltage, depending on load and on duty cycle. In this region, the value of the LDO_1 (5.0 V) as well as trackers 1 and 2 (nominal 5.0 V following LDO_1) might be affected.

The preregulator supplies the following outputs:

- LDO_1: 5 V, 800 mA
- LDO_2: 3.3 V or 2.6 V selectable, 700 mA
- LDO_3: 1.5 V (TLE7368E), 1.2 V (TLE7368-2E), 1.3 V (TLE7368-3E)
current capability depending on thermal dimensioning and current consumption of other post-regulators
- Tracker1: 5 V, 105 mA, output voltage referring to LDO_1
- Tracker 2: 5 V, 50 mA, output voltage referring to LDO_1

An additional LDO supplied from the input voltage is the Q_Standby, 1.0 V or 2.6 V selectable, 30 mA,

The TLE7368 family is deliverable in three versions, where the only difference is the output voltage of LDO_3:

- TLE7368 E: LDO_3 with 1.5 V output voltage
- TLE7368-2E: LDO_3 with 1.2 V output voltage
- TLE7368-3E: LDO_3 with 1.3 V output voltage

The TLE7368 is offered in the following package:

- Exposed pad package

Demoboards for each variant are available. The layout and the dimensioning of the parts is the same.

2 How to operate the demoboard

2.1 The demoboard

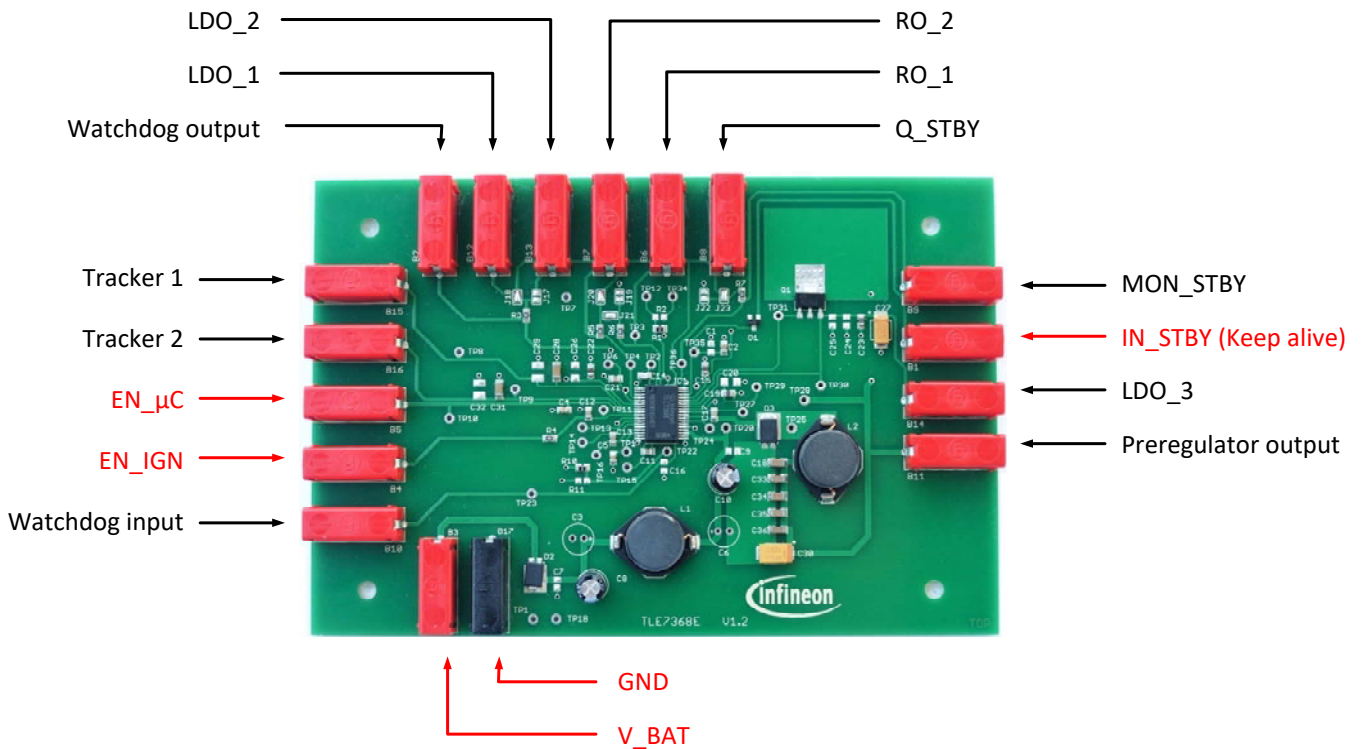

Figure 1 Demoboard topview

This view shows the TLE7368E version. The TLE7368-2E and TLE7368-3E are equivalent except in the variant marking on PCB and device. The general performance is the same despite the different output voltage of LDO_3

2.2 Quick start

The board is ready to operate.

Please refer to the figure above where mandatory ports for basic functionality are marked in red.

- Connect “GND” to Ground
- Connect “V_{BAT}” and “IN_STBY” (Keep Alive) to battery voltage
- With a high signal at “EN_μC” or/and “EN_IGN” the TLE7368E, TLE7368-2E and TLE7368-3E starts up

2.3 Port description

GND	Ground connection, please connect directly to the power supply
V _{BAT}	Input voltage supply for the preregulator
IN_STBY (Keep_Alive)	Input voltage for internal biasing and standby regulator
EN_μC	Enable input, signal from micro controller
EN_IGN	Enable input, signal from ignition
Preregulator output	Output of the preregulator, power supply for LDOs 1, 2 and 3 and trackers 1 and 2. Might be used to supply additional post regulators.
LDO_1	LDO_1 output, 5 V
LDO_2	LDO_2 output, pre-adjusted to 3.3 V
LDO_3	LDO_3 output: 1.5 V at TLE7368E variant, 1.2 V at TLE7368-2E variant, 1.3 V at TLE7368-3E variant
Tracker1	Tracker 1 output, 5 V
Tracker2	Tracker 2 output, 5 V
Q_STBY	Standby regulator output, pre-adjusted to 2.6 V
RO_1	Reset 1 output, monitoring LDO_1
RO_2	Reset 2 output, monitoring LDO_2 and LDO_3
MON_STBY	Monitoring output of standby regulator
WDI	Window watchdog input
WDO	Window watchdog output

Table 1 Port description (for detailed information please refer to the datasheet)

3 Schematic

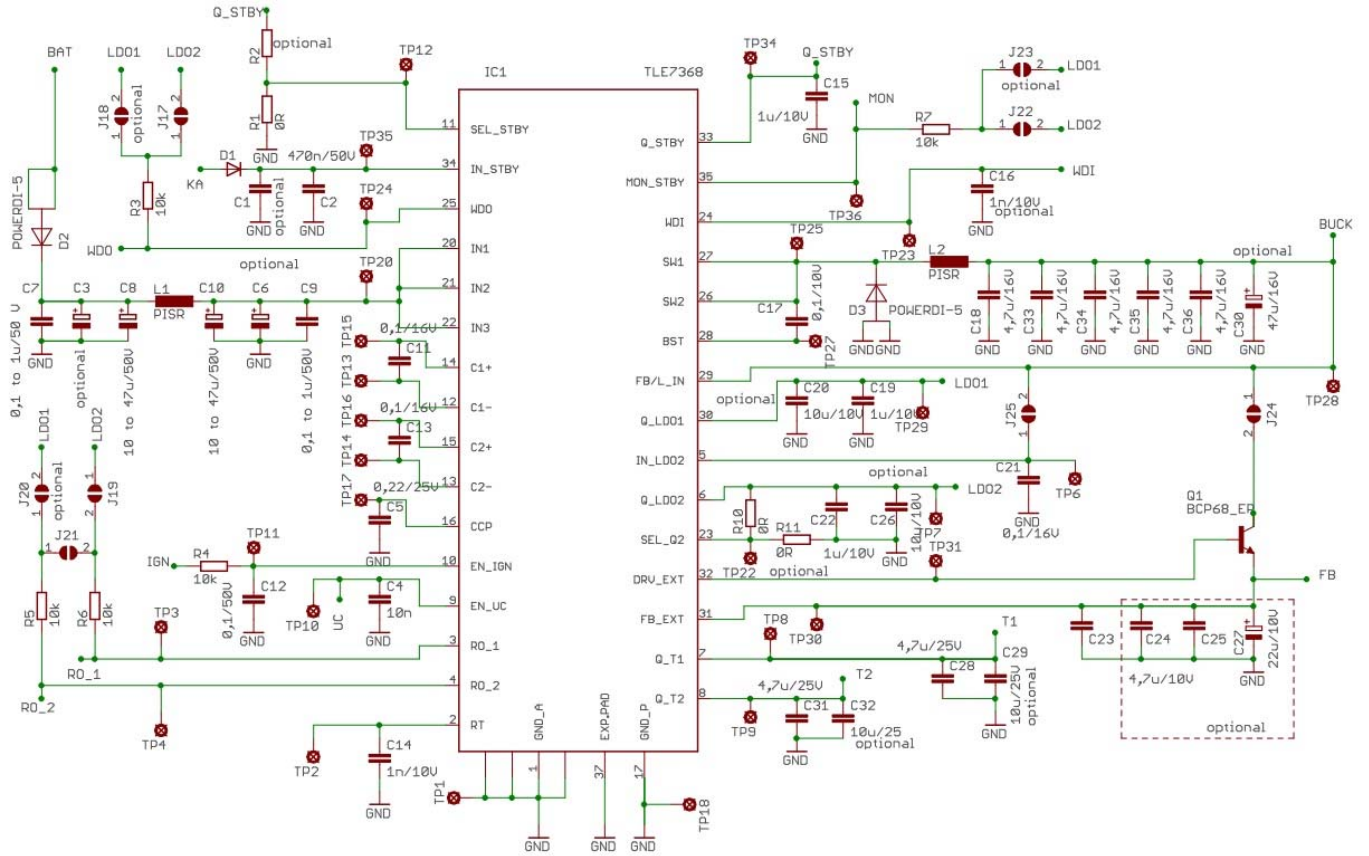

Figure 2 Demoboard schematic (The parts in the schematic marked with dotted frames or marked optional are not mounted.)

Jumpers on the board allow flexibility in using the device. The jumpers are shown in the schematic above. Some of the jumpers are already closed to allow for an immediate start-up. The default setting is:

J 17	supply of "WDO" from LDO 2	open
J 18	supply of "WDO" from LDO 1	closed
J 19	supply of "RO_1" (and "RO_2" with J21) from LDO 2	open
J 20	supply of "RO_2" (and "RO_1" with J21) from LDO 1	closed
J 21	supply "RO_1" and "RO_2" from LDO 1 or LDO 2	closed
J 22	supply of "MON_STBY" from LDO 2	open
J 23	supply of "MON_STBY" from LDO 1	closed
J 24	(bottom side of board) Supply of LDO3	closed
J 25	(bottom side of board) Supply of LDO2	closed

Table 2 **Default jumper setting**

4 Part list

Quantity	Value	Part		Part Number	PCB Footprint
1	CAP NP	C1			SM/C_0805
1	470nF 50V	C2	CAP CER .47UF 50V X7R 0805	GRM21BR71H474KA88L	SM/C_0805
1	CAP NP	C3			CYL/D.150/LS.100/.031SLOT
1	10nF 10V	C4	CAP 10000PF 50V CERAMIC X7R 0805	C0805C103K5RACTU	SM/C_0805
1	220nF 25V	C5	CAP CER .22UF 25V X7R 10% 0805	C2012X7R1E224K	SM/C_0805
1	CAP NP	C6			CYL/D.150/LS.100/.031SLOT
1	100nF to 1uF	C7	1μF/50V		SM/C_0805
1	10uF to 47uF	C8	22μF/50V		CYL/D.150/LS.100/.031SLOT
1	100nF to 1uF	C9	1μF/50V		SM/C_0805
1	10uF to 47uF	C10	47μF/50V		CYL/D.150/LS.100/.031SLOT
1	100nF 16V	C11	CAP CER .1UF 16V 10% X7R 0805	GRM219R71C104KA01D	SM/C_0805
1	100nF 50V	C12	CAP CER .10UF 50V X7R 10% 0805	C2012X7R1H104K	SM/C_0805
1	100nF 16V	C13	CAP CER .1UF 16V 10% X7R 0805	GRM219R71C104KA01D	SM/C_0805
1	1nF 10V	C14	CAP CERM 1000PF 16V C0G 5% 0805	B37947K9102J60	SM/C_0805
1	1uF 10V	C15	CAP CER 1.0UF 10V 10% X5R 0805	GRM219R61A105KC01D	SM/C_0805
1	1nF 10V	C16			SM/C_0805
1	100nF 10V	C17	CAP CER .1UF 16V 10% X7R 0805	GRM219R71C104KA01D	SM/C_0805
1	4.7uF 16V	C18	CAP CER 4.7UF 16V X7R 1206	GRM31CR71C475KA01L	SM/C_1206
1	1uF 10V	C19	CAP CER 1.0UF 10V 10% X5R 0805	GRM219R61A105KC01D	SM/C_0805
1	10uF 10V	C20			SM/C_1206
1	100nF 16V	C21	CAP CER .1UF 16V 10% X7R 0805	GRM219R71C104KA01D	SM/C_0805
1	1uF 10V	C22	CAP CER 1.0UF 10V 10% X5R 0805	GRM219R61A105KC01D	SM/C_0805
1	4.7uF 10V	C23	CAP CER 4.7UF 10V 10% X5R 0805	GRM219R61A475KE19D	SM/C_0805
1	4.7uF 10V	C24			SM/C_0805
1	4.7uF 10V	C25			SM/C_0805
1	10uF 10V	C26			SM/C_1206
1	10uF 25V	C27	CAP 10UF 25V	26D250	SM/C_1210
1	4.7uF 25V	C28	CAP 4.7UF 25V CERAMIC X5R 1206	ECJ-3YB1E475K	SM/C_1206
1	10uF 25V	C29			SM/C_1210
1	47uF 16V	C30			SM/CT_7343_12
1	4.7uF 25V	C31	CAP 4.7UF 25V CERAMIC X5R 1206	ECJ-3YB1E475K	SM/C_1206
1	10uF 25V	C32			SM/C_1210
1	4.7uF 16V	C33	CAP CER 4.7UF 16V X7R 1206	GRM31CR71C475KA01L	SM/C_1206
1	4.7uF 16V	C34	CAP CER 4.7UF 16V X7R 1206	GRM31CR71C475KA01L	SM/C_1206
1	4.7uF 16V	C35	CAP CER 4.7UF 16V X7R 1206	GRM31CR71C475KA01L	SM/C_1206
1	4.7uF 16V	C36	CAP CER 4.7UF 16V X7R 1206	GRM31CR71C475KA01L	SM/C_1206
1	MMBD914LT1	D1	DIODE ARRAY SWITCHING SOT-23	MMBD914LT1	SM/SOT23_132
1	PDS5100-13	D2	DIODE SCHOTTKY 100V 5A POWERDI5	PDS5100-13	POWERDI-5
1	PDS540	D3	DIODE SCHOTTKY 40V 5A POWERDI5	PDS540-13	POWERDI-5
1	Keep Alive	B1	CONN JACK STD INSUL HORIZ RED	571-0500	BANANA JACK
1	WDO	B2	CONN JACK STD INSUL HORIZ RED	571-0500	BANANA JACK
1	Battery Input	B3	CONN JACK STD INSUL HORIZ RED	571-0500	BANANA JACK
1	Ignition_enable	B4	CONN JACK STD INSUL HORIZ RED	571-0500	BANANA JACK
1	uC_enable	B5	CONN JACK STD INSUL HORIZ RED	571-0500	BANANA JACK
1	RO_1	B6	CONN JACK STD INSUL HORIZ RED	571-0500	BANANA JACK
1	RO_2	B7	CONN JACK STD INSUL HORIZ RED	571-0500	BANANA JACK
1	Q_STBY	B8	CONN JACK STD INSUL HORIZ RED	571-0500	BANANA JACK
1	MON_STBY	B9	CONN JACK STD INSUL HORIZ RED	571-0500	BANANA JACK

1	WDI	B10	CONN JACK STD INSUL HORIZ RED	571-0500	BANANA JACK
1	Buck-out	B11	CONN JACK STD INSUL HORIZ RED	571-0500	BANANA JACK
1	Q_LDO1	B12	CONN JACK STD INSUL HORIZ RED	571-0500	BANANA JACK
1	Q_LDO2	B13	CONN JACK STD INSUL HORIZ RED	571-0500	BANANA JACK
1	FB_EXT	B14	CONN JACK STD INSUL HORIZ RED	571-0500	BANANA JACK
1	Q_T1	B15	CONN JACK STD INSUL HORIZ RED	571-0500	BANANA JACK
1	Q_T2	B16	CONN JACK STD INSUL HORIZ RED	571-0500	BANANA JACK
1	Ground	B17	CONN JACK STD INSUL HORIZ BLACK	571-0400	BANANA JACK
1	JUMPER	J17			JUMPER2
1	JUMPER	J18			JUMPER2
1	JUMPER	J19			JUMPER2
1	JUMPER	J20			JUMPER2
1	JUMPER	J21			JUMPER2
1	JUMPER	J22			JUMPER2
1	JUMPER	J23			JUMPER2
1	JUMPER	J24			JUMPER2
1	JUMPER	J25			JUMPER2
1	10uH	L1	Power Inductor 10uH Fastron	PISR -100M-04 - 74D4812	DS5022
1	33uH/ 5A	L2	Power Inductor 33uH Fastron	PISR-330M-04 - 74D4818	DS5022
1	KSH200	Q1		KSH200TF	SM/SOT223/DPAK_1234 (*)
1	BCP68/SOT	Q1			SM/SOT223_1234
1		0 R1	RES 0.0 OHM 1/8W 5% 0805 SMD	ERJ-6GEY0R00V	SM/R_0805
1		0 R2			SM/R_0805
1	10K	R3	RES 10.0K OHM 1/8W 1% 0805 SMD	MCR10EZHF1002	SM/R_0805
1	10K	R4	RES 10.0K OHM 1/8W 1% 0805 SMD	MCR10EZHF1002	SM/R_0805
1	10K	R5	RES 10.0K OHM 1/8W 1% 0805 SMD	MCR10EZHF1002	SM/R_0805
1	10K	R6	RES 10.0K OHM 1/8W 1% 0805 SMD	MCR10EZHF1002	SM/R_0805
1	10K	R7	RES 10.0K OHM 1/8W 1% 0805 SMD	MCR10EZHF1002	SM/R_0805
1	R	R8			AX/.825X.200/.42
1	R	R9			AX/.825X.200/.42
1		0 R10	RES 0.0 OHM 1/8W 5% 0805 SMD	ERJ-6GEY0R00V	SM/R_0805
1		0 R11			SM/R_0805
1	TLE7368	U1			TLE7368

Table 3 Part list (Parts in grey are not mounted)

(*) The KSH200TF is discontinued and not recommended for new designs. It has been replaced, however some demoboards may still contain this transistor.

5 Layout

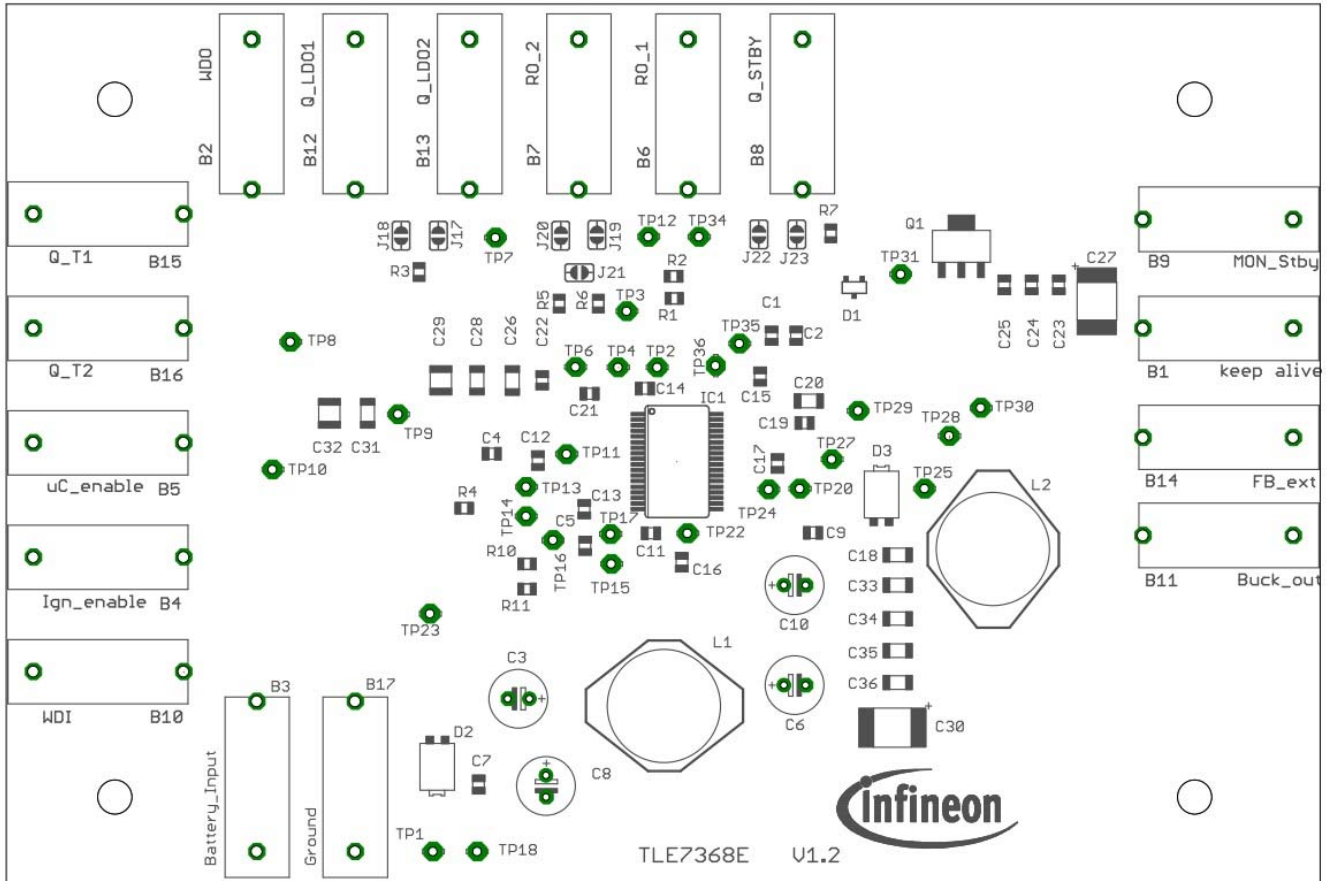

Figure 3 Mounting plan (positioning of the components)

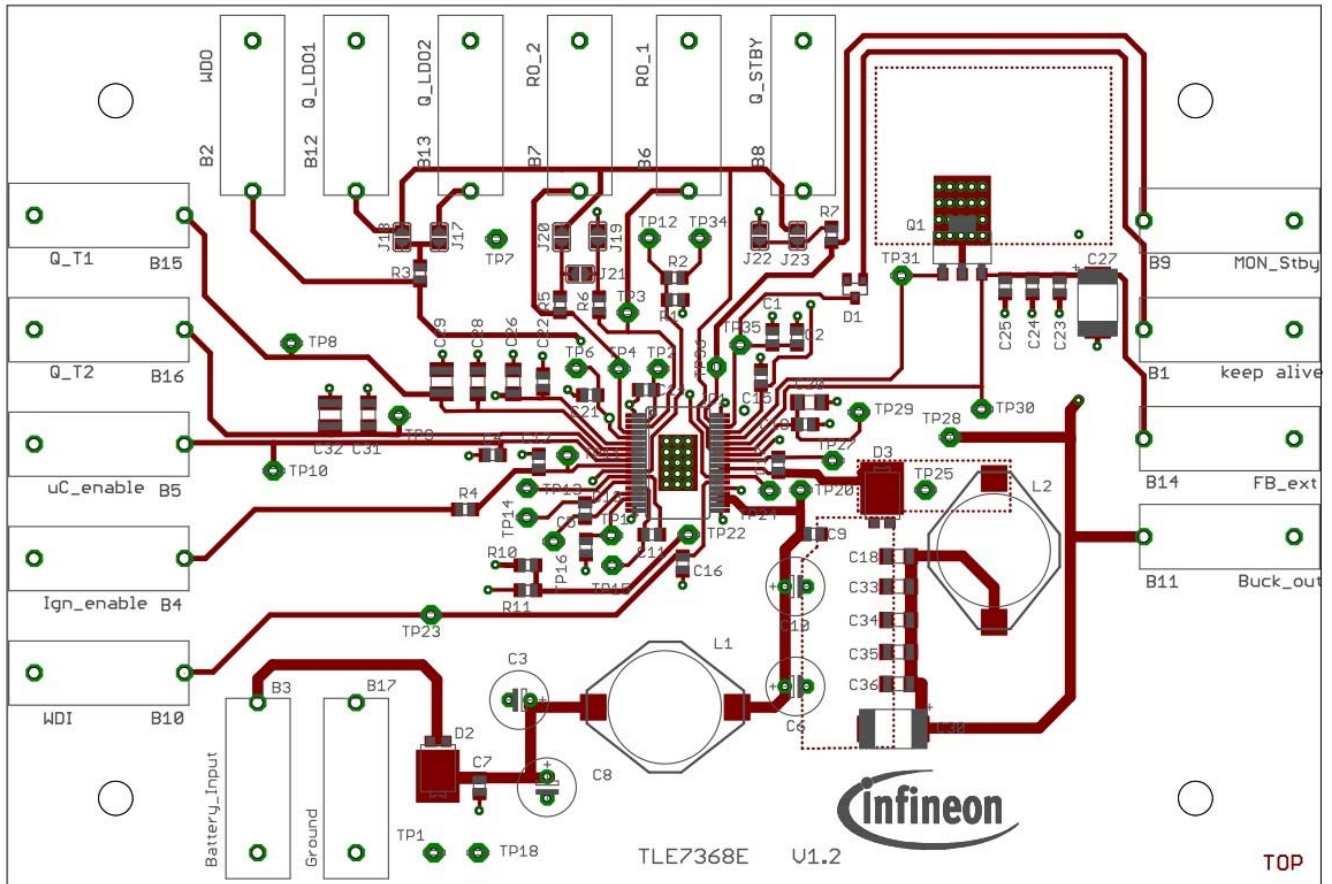

Figure 4 Layout (top layer) and positioning of the components

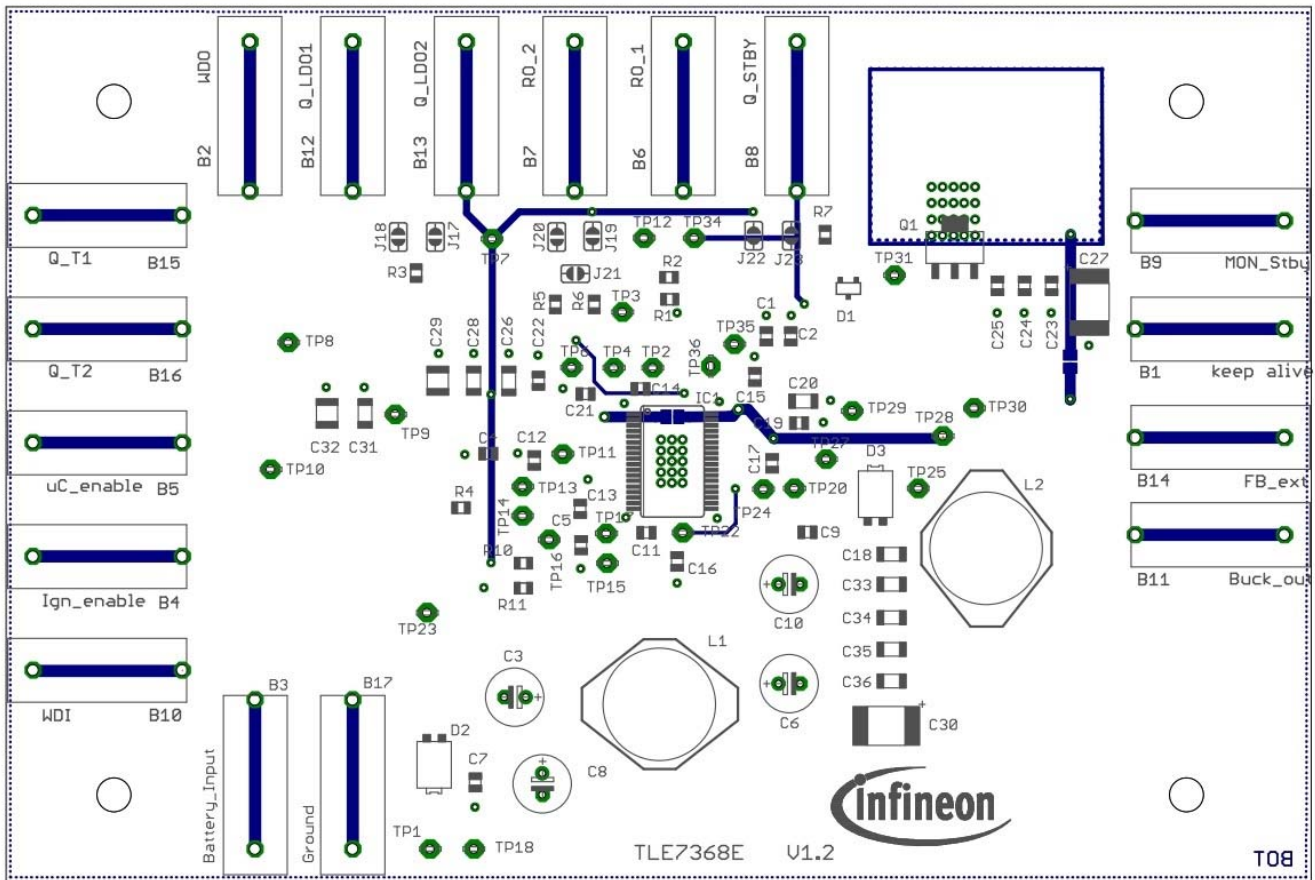

Figure 5 Layout (bottom layer) and positioning of the components

The demoboard is a two-layer board equipped with a complete ground (=bottom) layer. For EMC optimization the board uses an input π -filter consisting of C3, C7, C8, L1, C6, C9 and C10 (partly not mounted), thus conducted emissions back to the battery line as well as disturbances from outside will be suppressed.

For proper operation and to avoid stray inductances on the layout, the input capacitor(s) C6, C9 and C10 as well as the output filter elements D3 (freewheeling diode), L2, C18, C30, C33, C34, C35 and C36 have to be placed as close to the TLE7368as possible.

6 Additional information

- Please contact your local Infineon representative for additional information
- For further information you may contact <http://www.infineon.com/>

Revision history

Major changes since the last revision

Page or Reference	Description of change
Rev 1.0	First version 2008-09-30
Rev 2.0	Second version 2020-07-15