

Introduction

The VersaClock 3S (VC3S) universal USB development kit is designed to support the 5x3502x family of VC3S devices. It provides a convenient way of verifying, configuring and programming the blank parts for all VC3S devices. The IDT Timing Commander GUI communicates to the devices for configuration and frequency validation on the board via an on-board USB interface. Using additional socket boards, a validated configuration is used to program blank parts for any of the VC3S devices. The table below shows the available VC3S development kits and their voltage ratings.

Table 1. List of VersaClock 3S Family Development Kits Available

Development Kit Part Number	Product Applies to
DEV5P35023	5P35023
DEV5P35021	5P35021
DEV5L35023	5L35023
DEV5L35021	5L35021

Development Kit Board Overview

The USB development kit board is ready with all of the necessary components and connections to test the functionality of the configuration. See [Figure 1](#) below and [Table 2](#) for a list of component labels and descriptions. The devices can be programmed with the additional socket board as shown in [Figure 2](#).

Figure 1. Verification Board-top view

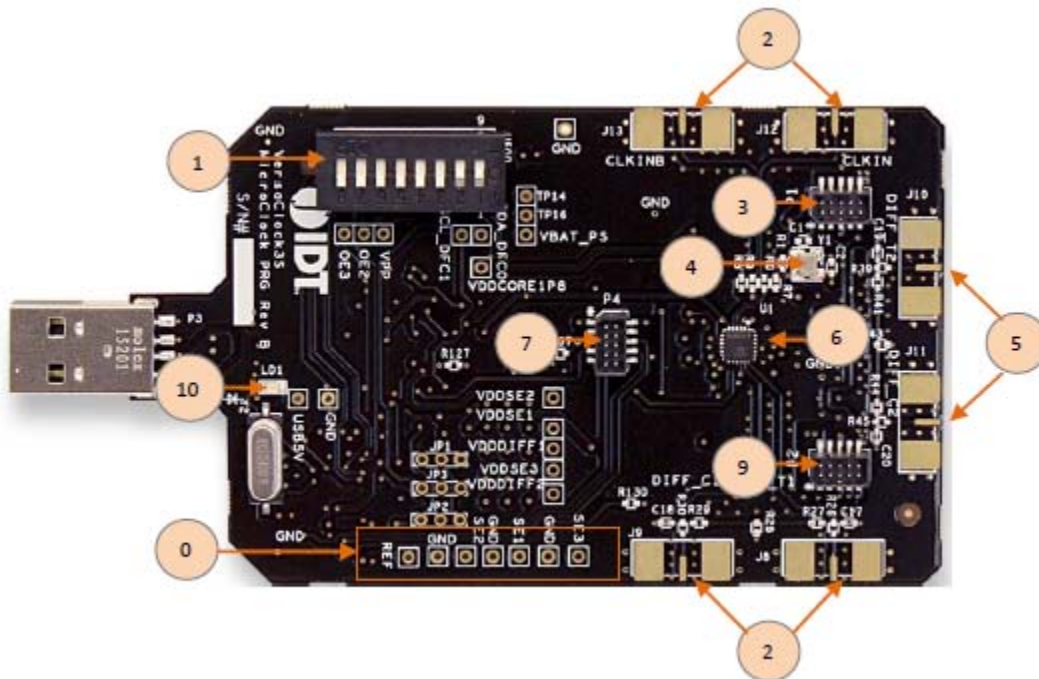
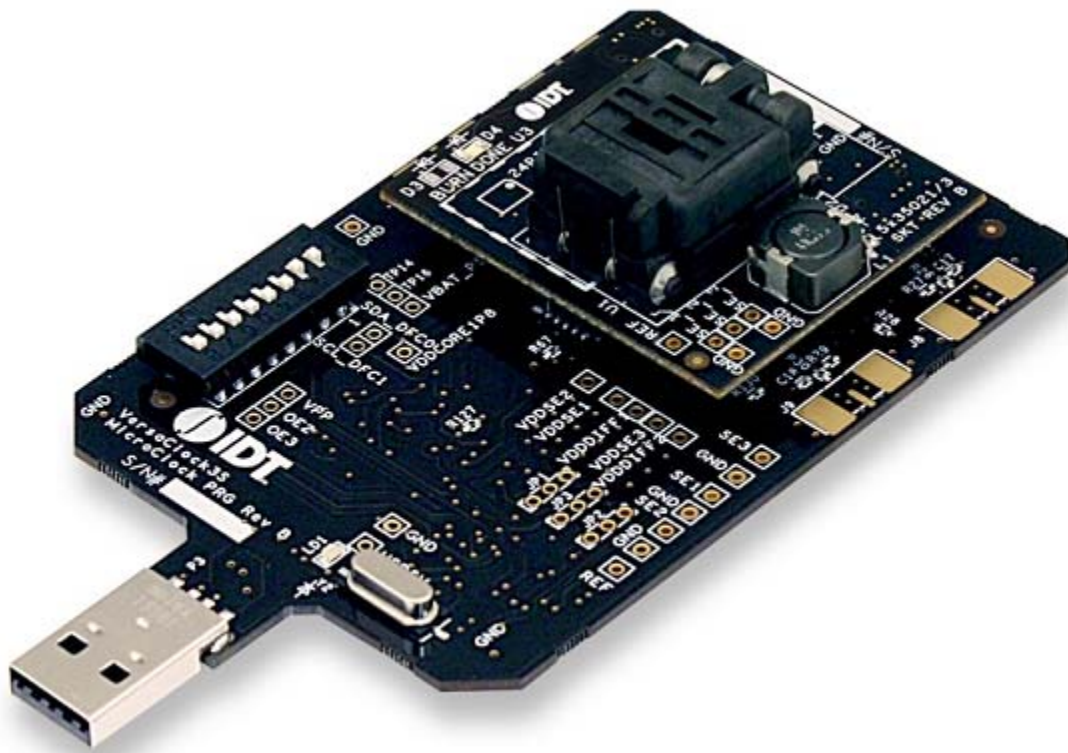

Table 2. USB Development Kit Board Descriptions

Label Number	Label Name	Description
0	Single-ended Outputs	These are test points for single-ended outputs; SE1, SE2, SE3 and reference with GND test points in between.
1	DIP Switch	Used to configure the device in different modes.
2	Clock Inputs	A differential clock can be connected as the source for the device or a single-ended input connected on CLKINB pin.
3	Socket Connector	Used to mount a 24-pin or 20-pin socket board on the top of USB board for programming.
4	25MHz Crystal	Crystal with 8pF load (part number: 603-25-150) is populated.
5	Differential Output #2	The differential pair (out of phase) for DIFF-T2 and DIFF-C2.
6	IDT VersaClock 3S Device	Device is populated on this programmer board.
7	Socket Connector	Used to mount a 24-pin or 20-pin socket board on the top of USB board for programming.
8	Differential Output #1	The differential pair (out of phase) for DIFF-T1 and DIFF-C2.
9	Socket Connector	Used to mount a 24-pin or 20-pin socket board on the top of USB board for programming.
10	LED1	LED to indicate VC3S chip is powered by USB port.

Figure 2. Verification Board Connected with Socket Programming Board



The VersaClock 3S device on the verification board is used for the purpose of validation and measurement on all outputs. After a configuration is validated on the programmer board, the programmer board can be connected along with the specific socket board for programming on VC3S devices. Note that blank parts can only be burnt once through the socket board. The socket boards are available in mainly two variations: 20-pin and 24-pin for all VC3s devices. The following description and images are restricted to the 24-pin socket board.

When the socket is open, identify the position of pin 1 as shown in [Figure 3](#). Align the dot of the blank part with the round dent engraved on the corner of the socket as pointed. After placing the blank part, secure the socket cover.

Figure 3. Socket Board (pin position)

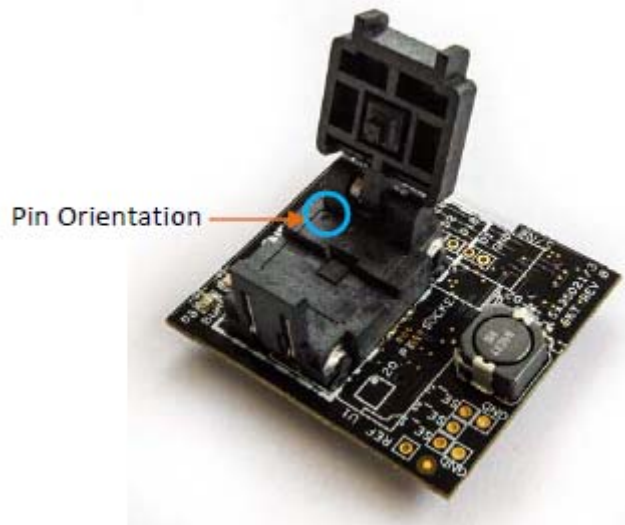



Programming Steps

Use programming steps 2 – 7 as described in the [Table 3](#) to program a configuration into the blank part in the specified socket board.

Table 3. Programming Steps

Step Number	Step Description	Comments
0	A configuration has been validated and completed on the development kit.	Configurations should have been validated on the programmer board and are ready to proceed for programming on blank parts.
1	All intended outputs should be available for measurement on the USB development kit.	Upon validation of the outputs, “Disconnect” the USB board and proceed for OTP burn as explained in the following sections.
2	Plug the specified socket board onto the USB development kit (shown in Figure 2).	USB programmer board with the socket board provides a communication channel between the GUI and a blank part in the socket board.
3	Start Timing Commander software (this step can be skipped if a configuration is ready in the personality).	Launch the Timing Commander GUI software. Load the personality file.

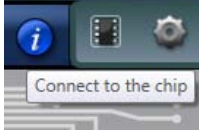
Table 3. Programming Steps (Cont.)

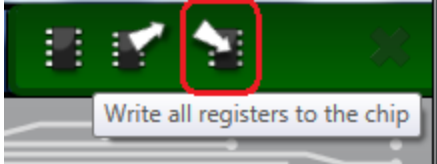
Step Number	Step Description	Comments
4	New settings file (this step can be skipped if a configuration is ready in the personality).	Using the Timing Commander GUI, start a new settings file or open a pre-optimized file.
5	Connect to the development kit.	Click on the chip symbol on the top right corner of the GUI window. 
6	—	Once connected, new options will be available on a green background indicating that the USB board has successfully connected with the board. 
7	Click the “write all” icon.	The configuration will be programmed into the blank part in the socket. 

Use the following steps to proceed with the OTP burn.

- After the chip is connected to the Timing Commander, the main window of configuration is shown (see Figure 4). Click the OTP icon on the left side of personality window.

Figure 4. Personality Main Window

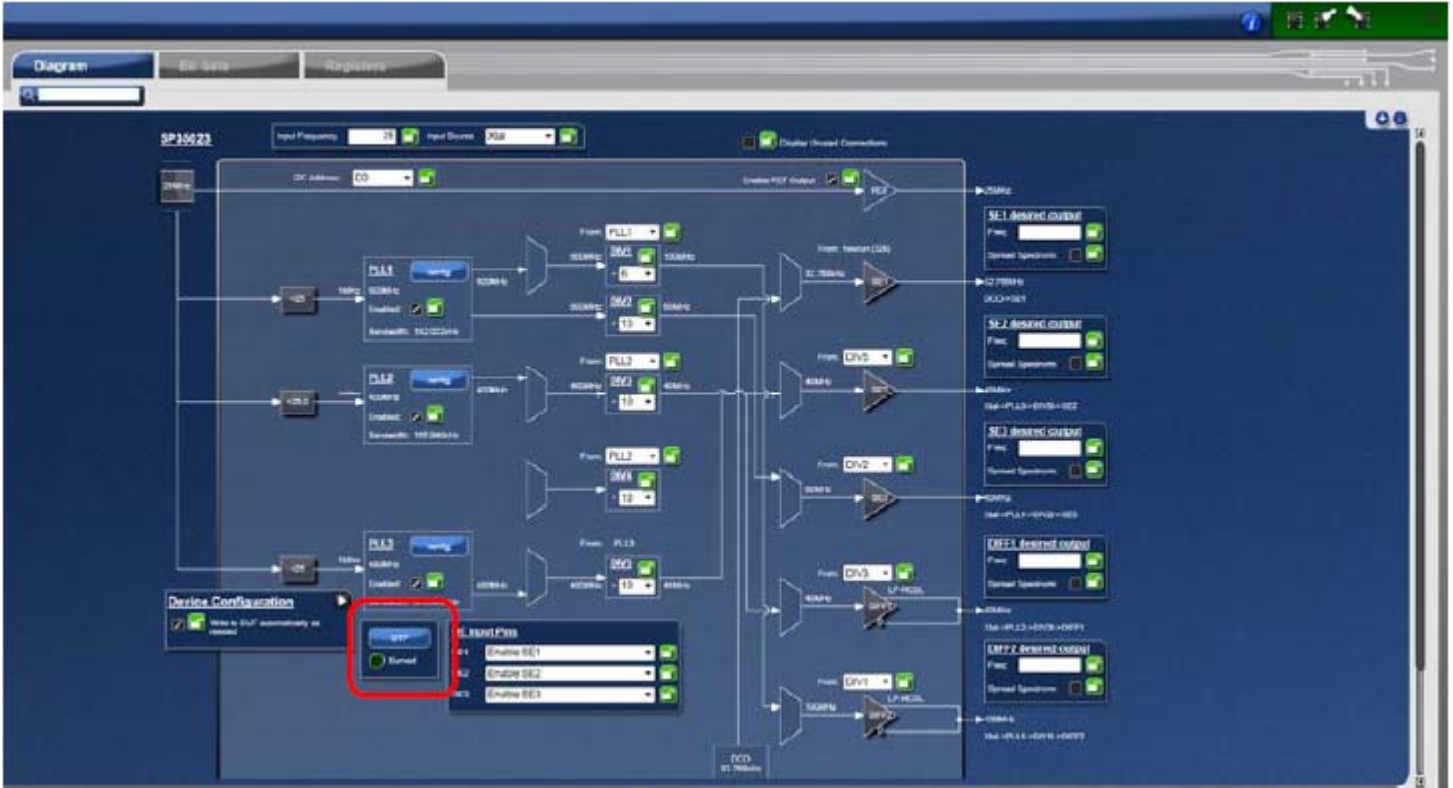

- After clicking the icon, a new dialogue window will open up (see Figure 5). Click “Yes” to proceed with the OTP burn process. Please note that this process cannot be reverted back.

Figure 5. Proceed to Burn Dialog Window

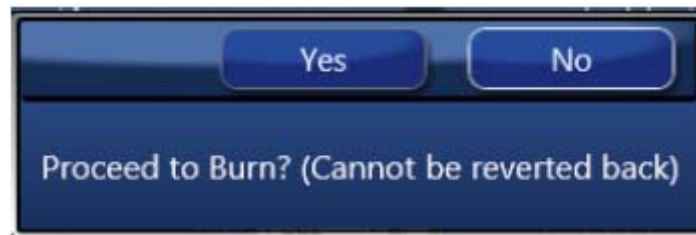

- If the OTP burn process is successful, a dialog window with “Success” will appear indicating that the process is completed and the part has been burnt based on the configuration.

Figure 6. Success Dialog Window

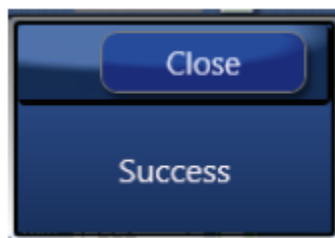

Schematics

Figure 7. USB Development Kit Board Schematic 1

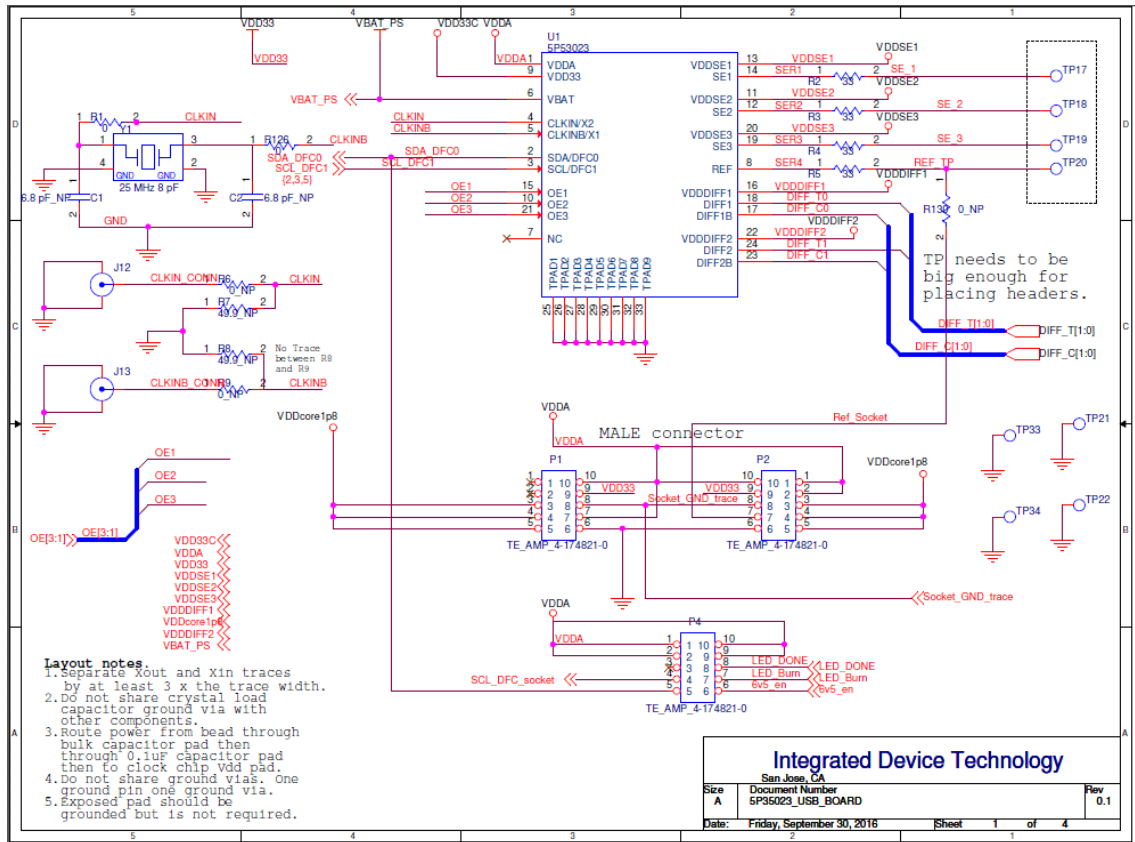

Figure 8. USB Development Kit Board Schematic 2

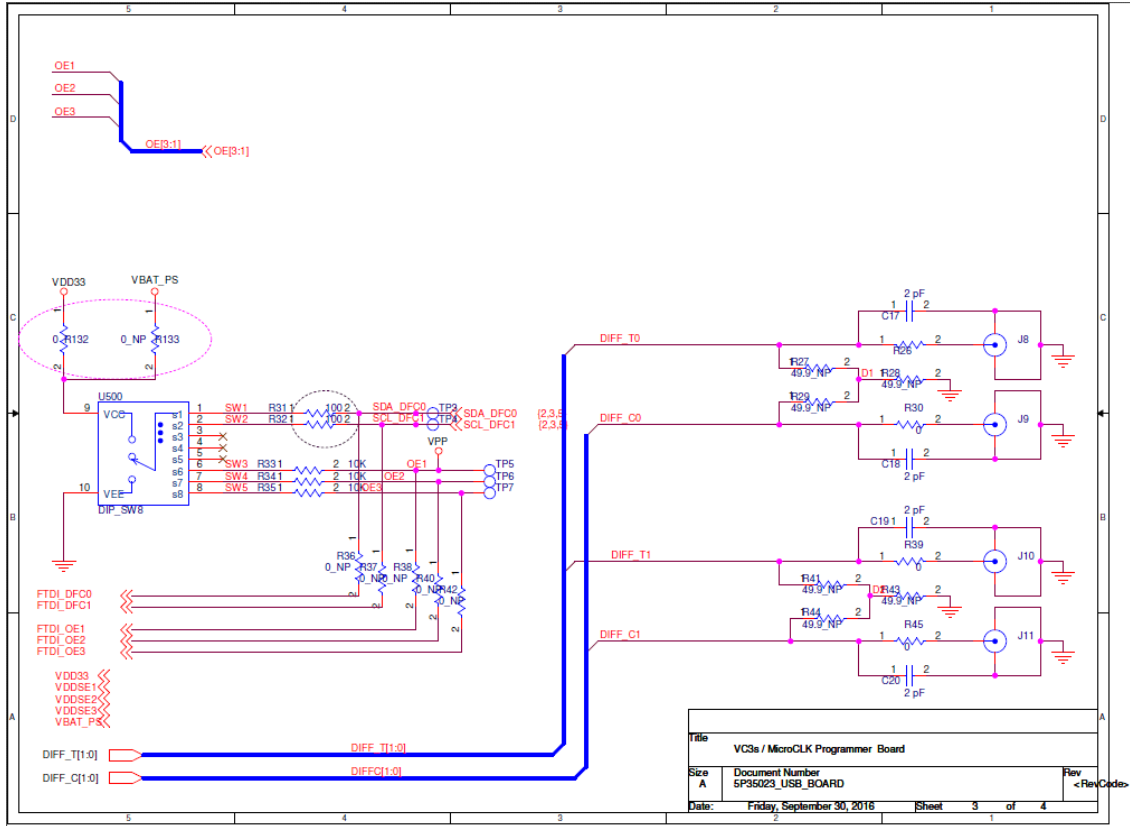

Figure 9. USB Development Kit Board Schematic 3

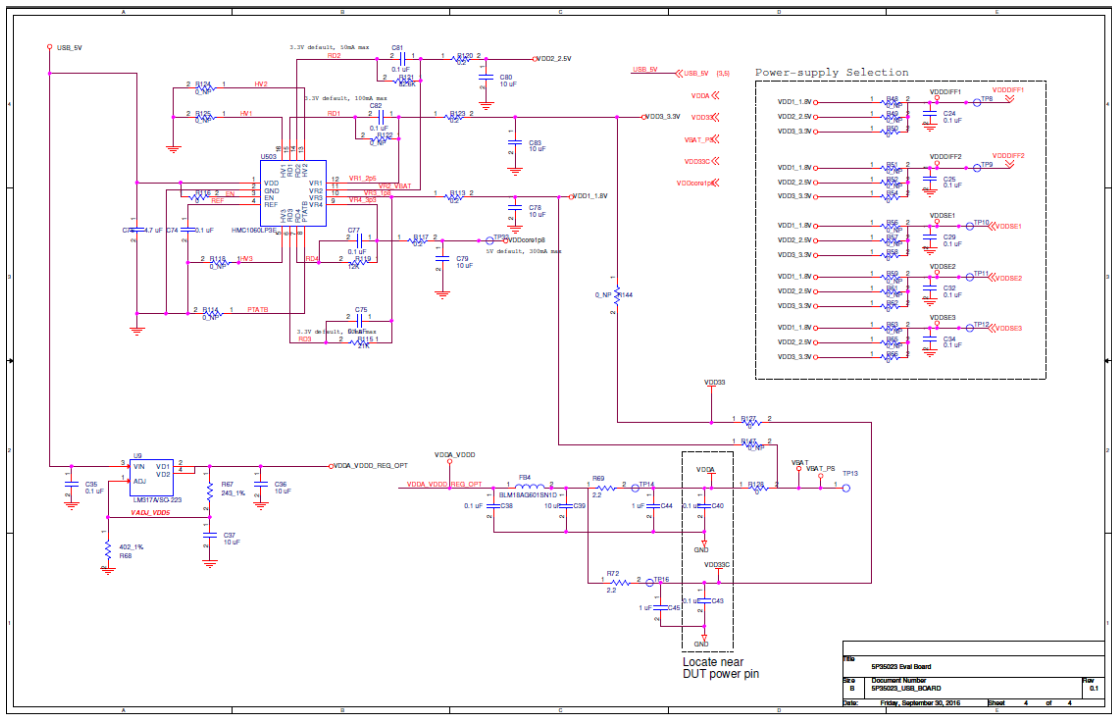
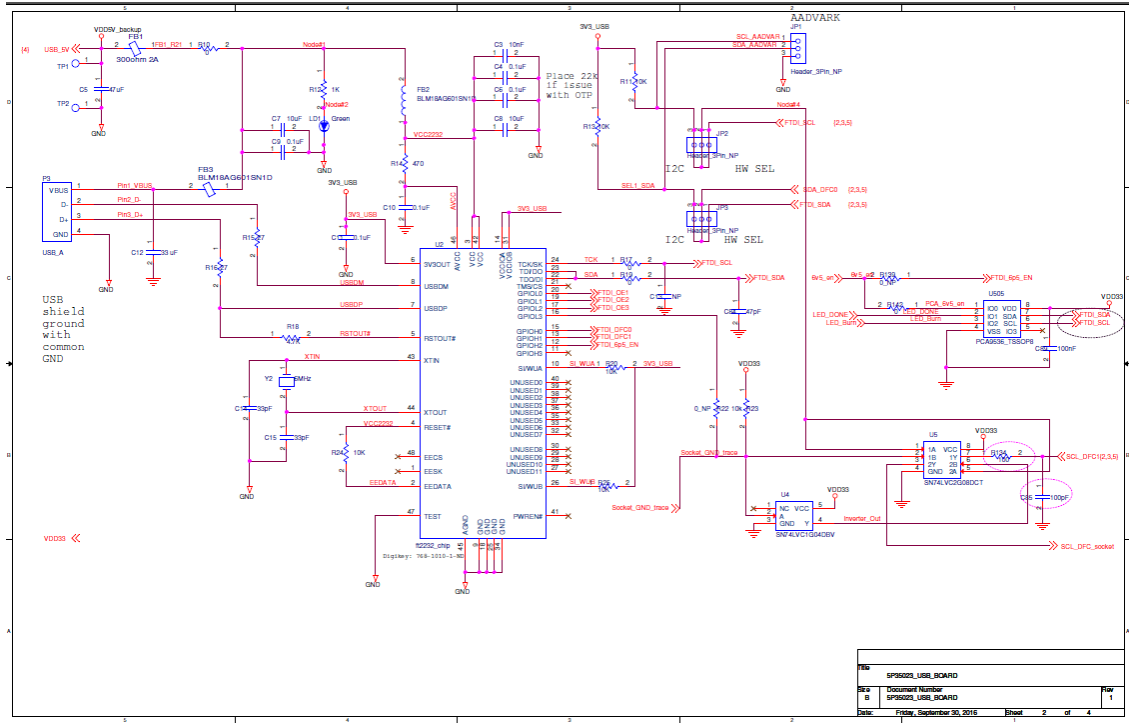

Figure 10. USB Development Kit Board Schematic 4



Termination Options

The resistor network is not installed for differential outputs in Tables 4 and 5 because an oscilloscope with internal 50Ω termination is utilized for signal termination and measurement. If an AC-coupled, stand-alone LVPECL output is needed (without oscilloscope connections), the 4-resistor network needs to be installed accordingly.

Table 4. Termination Options for Differential Outputs (DIFF - T0/C0)

Signal Type	Series Capacitors	Resistor Network		
	C17, C18	R27, R29	R28	R26, R30
LPHCSL	2pF	Not Installed	Not Installed	Installed

Table 5. Termination Options for Differential Outputs (DIFF - T1/C1)

Signal Type	Series Capacitors	Resistor Network		
	C19, C20	R41, R44	R43	R39, R45
LPHCSL	2pF	Not Installed	Not Installed	Installed

Table 6. Termination Options for Single-ended Output -1

Signal Type	Series Resistor, R2
LVC MOS	33Ω

Table 7. Termination Options for Single-ended Output -2

Signal Type	Series Resistor, R3
LVC MOS	33Ω

Table 8. Termination Options for Single-ended Output -3

Signal Type	Series Resistor, R4
LVC MOS	33Ω

Table 9. Termination Options for REF Output

Signal Type	Series Resistor, R5
LVC MOS	33Ω

Revision History

Table 10. Revision History

Revision Date	Description of Change
May 4, 2017	Initial release.