

3M™ DIN C-FORM & R-FORM PLUG, DIN 41612 SERIES
 VERTICAL, RIGHT ANGLE, SOLDER TAIL OR PRESS-FIT TERMINATION, .100" BACKPLANE REAR PLUG

NOTES
 1. REGULATORY INFORMATION:
 VISIT 3M.com/regs
 2. IN THE EVENT OF CONFLICT
 BETWEEN THIS DATA AND THAT
 CONTAINED IN THE PRODUCT
 SPECIFICATION, THE PRODUCT
 SPECIFICATION TAKES PRECEDENT.

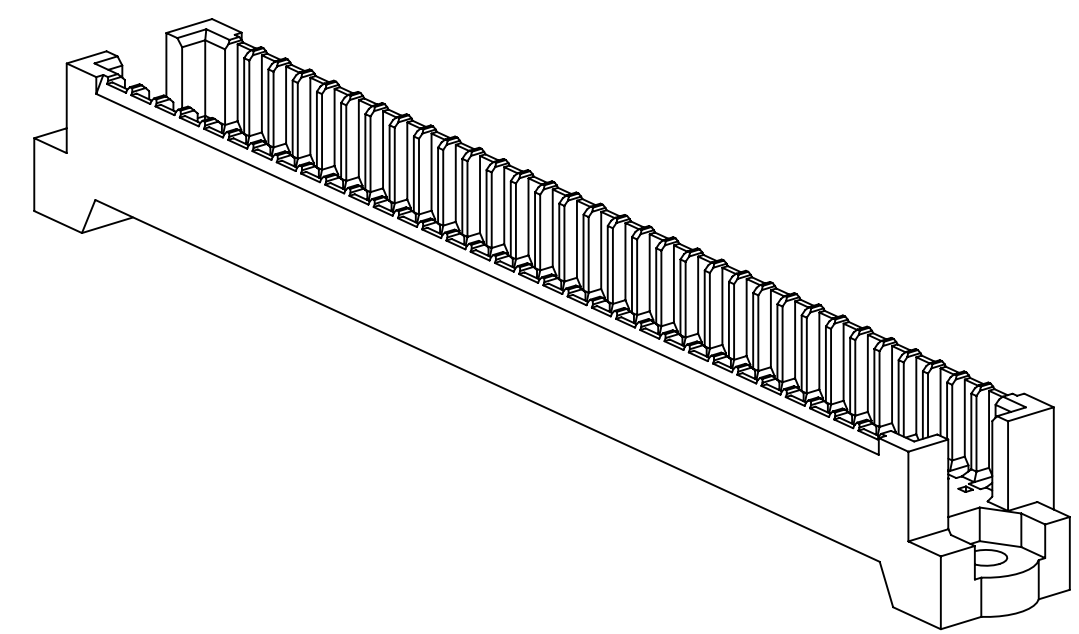

DIN-XXXSH-XXX-X
 .100" BACKPLANE, REAR PLUG SHROUD

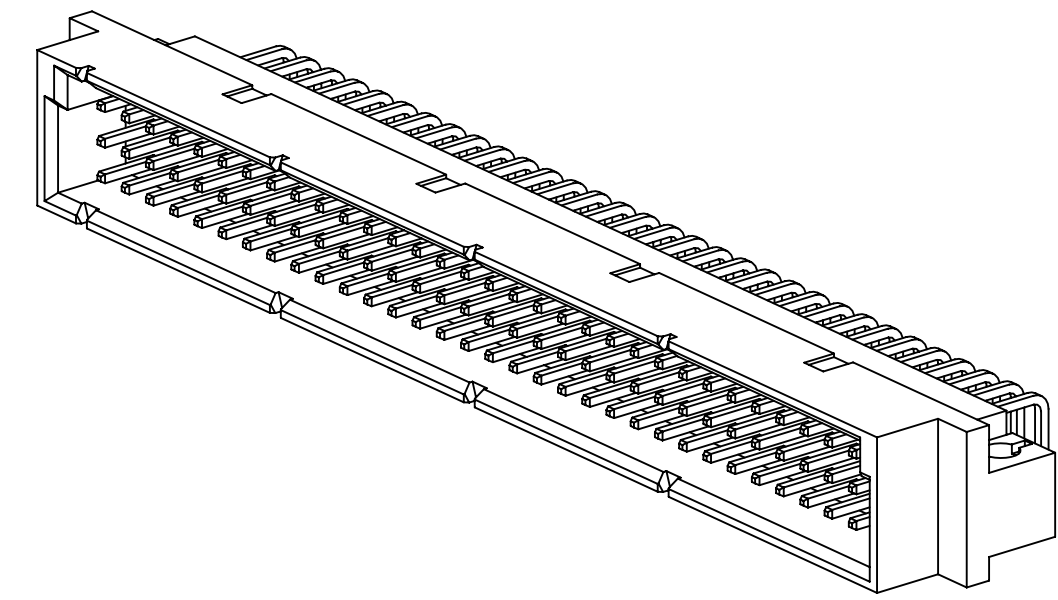

DIN-XXXCPX-XXX
 RIGHT ANGLE VERSION

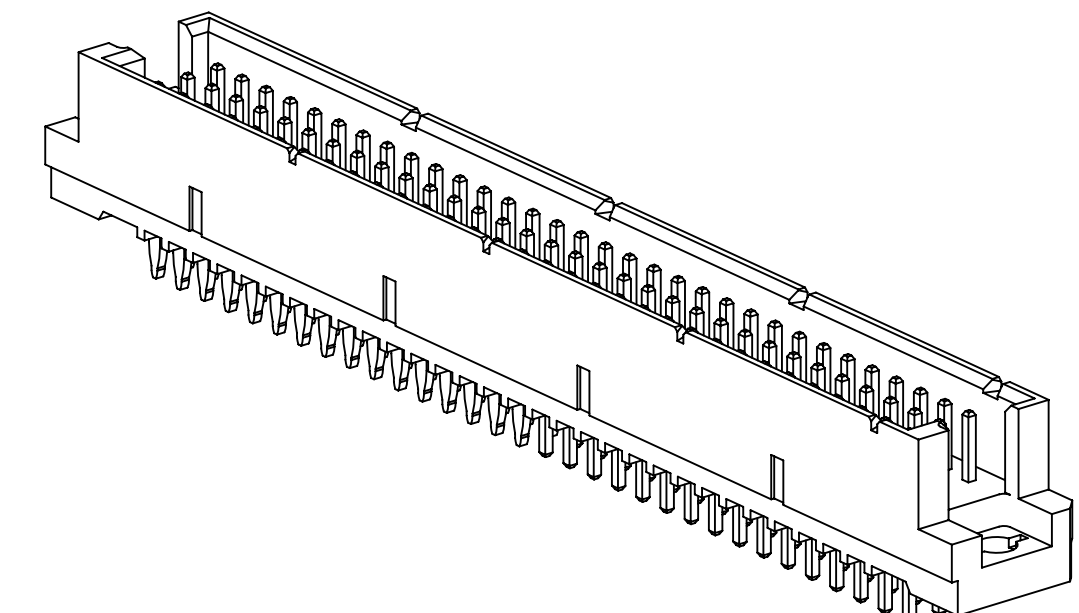

DIN-XXXRPX-XXX
 VERTICAL VERSION

2 PHYSICAL :

INSULATOR: GLASS FILLED POLYESTER (PBT)
 MATERIAL: GLASS FILLED POLYESTER (PBT)
 FLAMMABILITY: UL94V-0
 COLOR: GRAY
 CONTACT: COPPER ALLOY
 MATERIAL: COPPER ALLOY
 PLATING: 50μ" MIN. NICKEL
 UNDER PLATING: SEE ORDERING INFORMATION
 WIPING AREA: SEE ORDERING INFORMATION
 TERMINATION AREA: SEE ORDERING INFORMATION

2 ELECTRICAL :

CURRENT RATING: 3.0A AT 30°C T-RISE ABOVE AMBIENT
 CONTACT RESISTANCE: ≤ 20mΩ
 INSULATION RESISTANCE: ≥ 5,000 MΩ, 500 V_{ac}
 WITHSTANDING VOLTAGE: 1,000V_{ac} FOR 1 MINUTE

2 ENVIRONMENTAL :

TEMPERATURE RATING: -55°C TO 125°C
 PROCESS TEMPERATURE RATING: MAX. INSULATOR TEMPERATURE 191°C
 (SOLDER WAVE PROCESS ONLY)

MM [INCH]		
TOLERANCE - UNLESS NOTED		
	X.	.XX
MM	±.50	±.25 ±.15
[INCH]	±.020	±.010 ±.006
[] = DIM. FOR REFERENCE ONLY		

3M ELECTRONICS MATERIALS SOLUTIONS DIVISION
 INTERCONNECT SOLUTIONS
<http://www.3M.com/interconnect>

3M IS A TRADEMARK OF 3M COMPANY.
 FOR TECHNICAL, SALES OR ORDERING
 INFORMATION CALL 800-225-5373

DIMENSIONS: MM [INCHES]
 [INCHES] IS REF. ONLY



UL FILE NO: E68080

REV	ECO	ISSUE DATE AND DESCRIPTION	DRFT	CHKD
C	97226	MAY 25, 2021 REVISED INSULATION RESISTANCE	JNC	SAN
B	73823	MAY 30, 2017 REMOVE PLATING SH & FJ	JNC	WL
A	72454	FEB 24, 2017 PRODUCTION RELEASE	JNC	WL

DESIGN REFERENCE	NEXT ASSEMBLY	REV	ECO	ISSUE DATE AND DESCRIPTION	DRFT	CHKD
		DRFT	CASTIGLIONE	FEB 20, 2017	MFG	DATE
		CHKD		DATE	APPLY	DATE
					W. LEE	FEB 20, 2017
DIVISION	DIVISION CODE	© 3M COPYRIGHT 2021 This document and the information it contains are 3M property and may not be reproduced or further distributed without 3M permission, or used or disclosed other than for 3M authorized purposes. All rights reserved.				
DO NOT SCALE DRAWING	SCALE 2/1	TOLERANCES EXCEPT AS NOTED INCHES .0 ± .00 ± .000 ± .0000 ± MILLIMETERS 0 ± .0 ± .00 ± .000 ± .000 ± ANGLES ±				
THIRD ANGLE PROJECTION	INTERPRET PER ASME Y14.5 - 2018	TITLE DIN C & R-FORM PLUG, RA, VERT, SOLDER TAIL OR PRESS-FIT				
MAX SURFACE ROUGHNESS	ALL SURFACES	CAGE NUMBER	SIZE	DRAWING NO.	REV.	
<input checked="" type="checkbox"/> MARKED ONLY		D		78-5100-2671-5	C	
		MODEL			DET	ISTS <input type="checkbox"/> YES <input checked="" type="checkbox"/> NO SHT 1 OF 5

78-5100-2671-5
DRAWING NUMBER

A

3M™ DIN C-FORM & R-FORM PLUG, DIN 41612 SERIES
 VERTICAL, RIGHT ANGLE, SOLDER TAIL OR PRESS-FIT TERMINATION, .100" BACKPLANE REAR PLUG

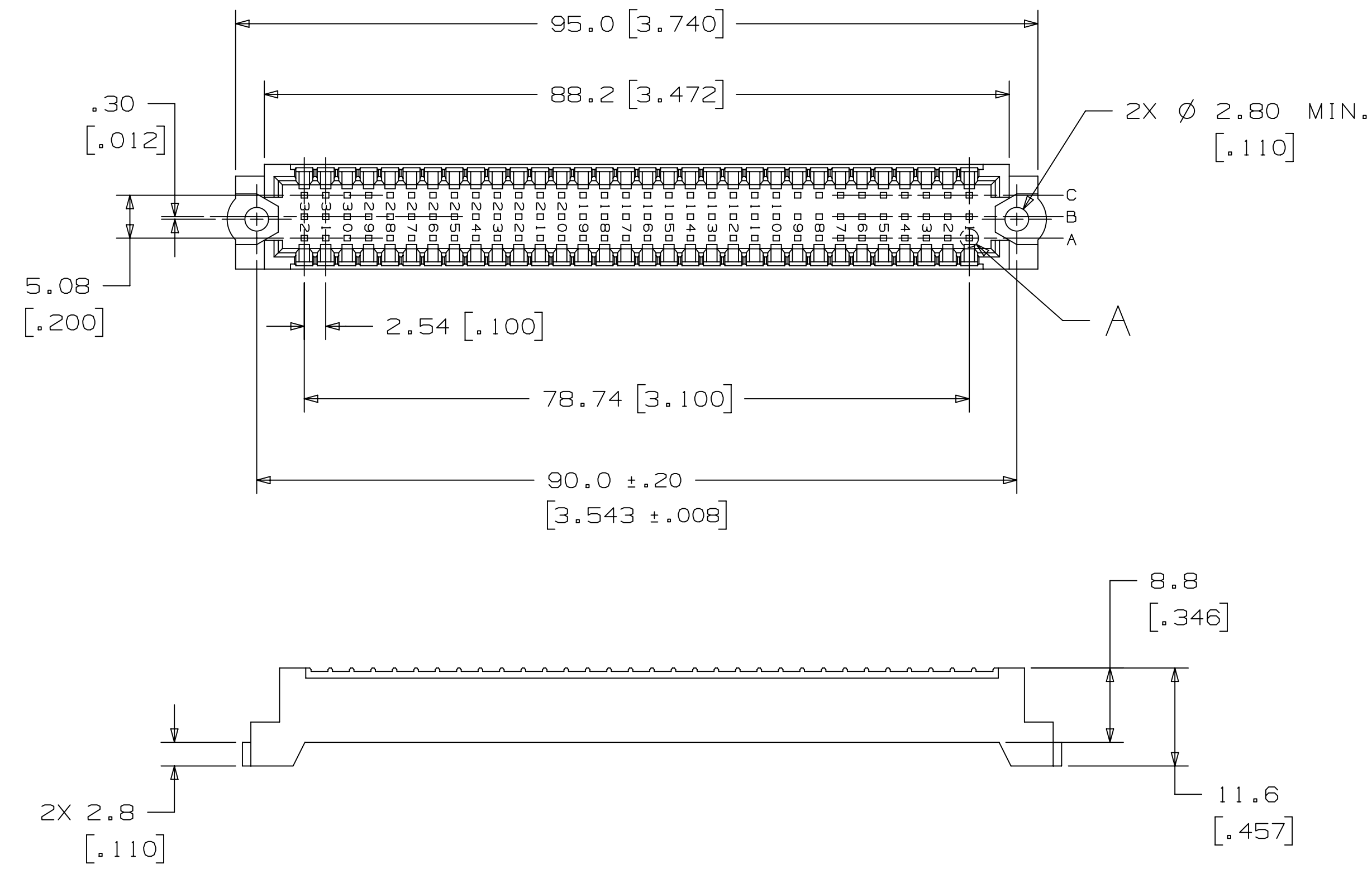

ORDERING INFORMATION
 C-FORM AND R-FORM SHROUD VERSION

DIN-XXXSH-XXX-X

CONTACT QUANTITY:
 096 = 3 X 32

PIN FIT OPTION:
 Q = HAND PRESS-FIT

BODY HEIGHT:
 457 = 11.6 [.457]

THIS DIAGRAM SERVES ONLY FOR PART NUMBER DESCRIPTIVE DEFINITIONS.
 PLEASE CONTACT YOUR LOCAL SALES REPRESENTATIVE FOR CUSTOMER SPECIFIC
 PRODYCT CONFIGURATIONS.

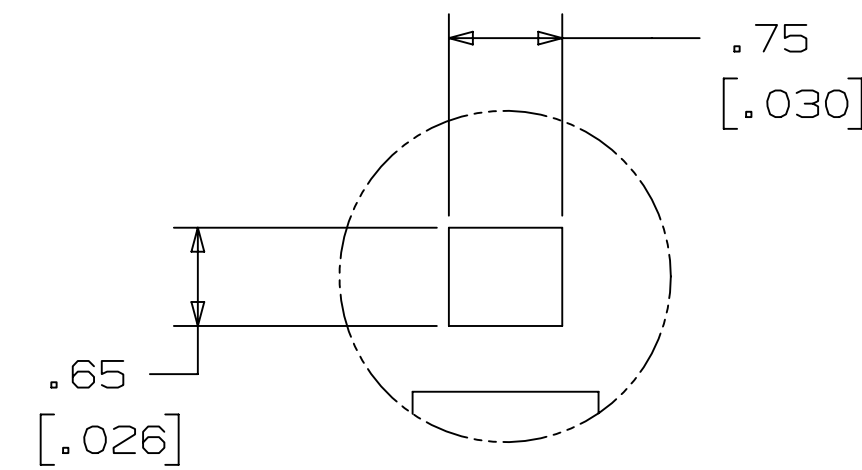
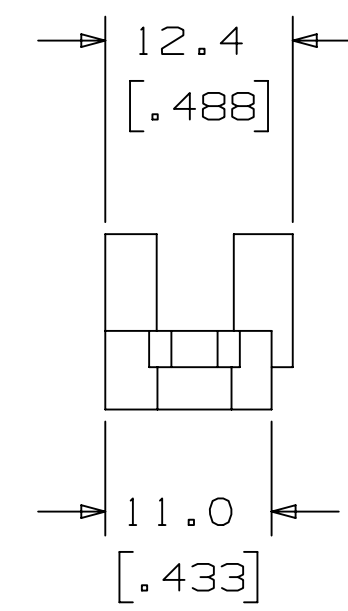

Detail A
 SCALE 20x
 HAND SLIP-ON OPTION

DESIGN REFERENCE	NEXT ASSEMBLY	REV	ECO	ISSUE DATE AND DESCRIPTION	DRFT	CHKD
		C	97226	MAY 25, 2021 REVISED INSULATION RESISTANCE	JNC	SAN
		B	73823	MAY 30, 2017 REMOVE PLATING SH & FJ	JNC	WL
		A	72454	FEB 24, 2017 PRODUCTION RELEASE	JNC	WL
				FEB 20, 2017		

DO NOT SCALE DRAWING	SCALE	TOLERANCES EXCEPT AS NOTED	INCHES	MILLIMETERS
	2/1		.00 ± .000 ± .0000 ±	0 ± .00 ± .000 ±

MAX SURFACE ROUGHNESS	MARKED ONLY	MODEL	DET	IS1s	YES	NO	SHT	2	OF	5

3M	3M Center St. Paul, MN 55144	© 3M COPYRIGHT 2021
This document and the information it contains are 3M property and may not be reproduced or further distributed without 3M permission, or used or disclosed other than for 3M authorized purposes. All rights reserved.		
TITLE		DIN C & R-FORM PLUG, RA, VERT, SOLDER TAIL OR PRESS-FIT
CAGE NUMBER	SIZE	DRAWING NO.
D		78-5100-2671-5
REV.	C	

78-5100-2671-5
 DRAWING NUMBER

A

3M™ DIN C-FORM & R-FORM PLUG, DIN 41612 SERIES
 VERTICAL, RIGHT ANGLE, SOLDER TAIL OR PRESS-FIT TERMINATION, .100" BACKPLANE REAR PLUG

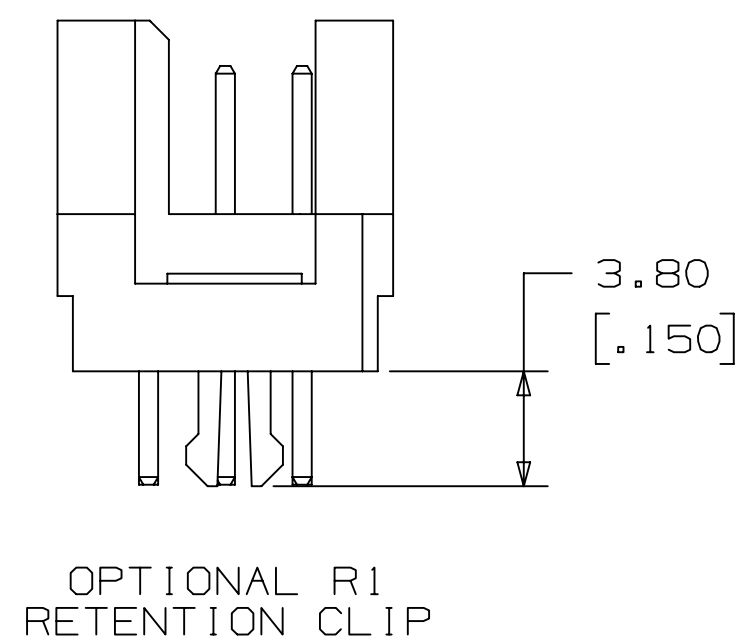
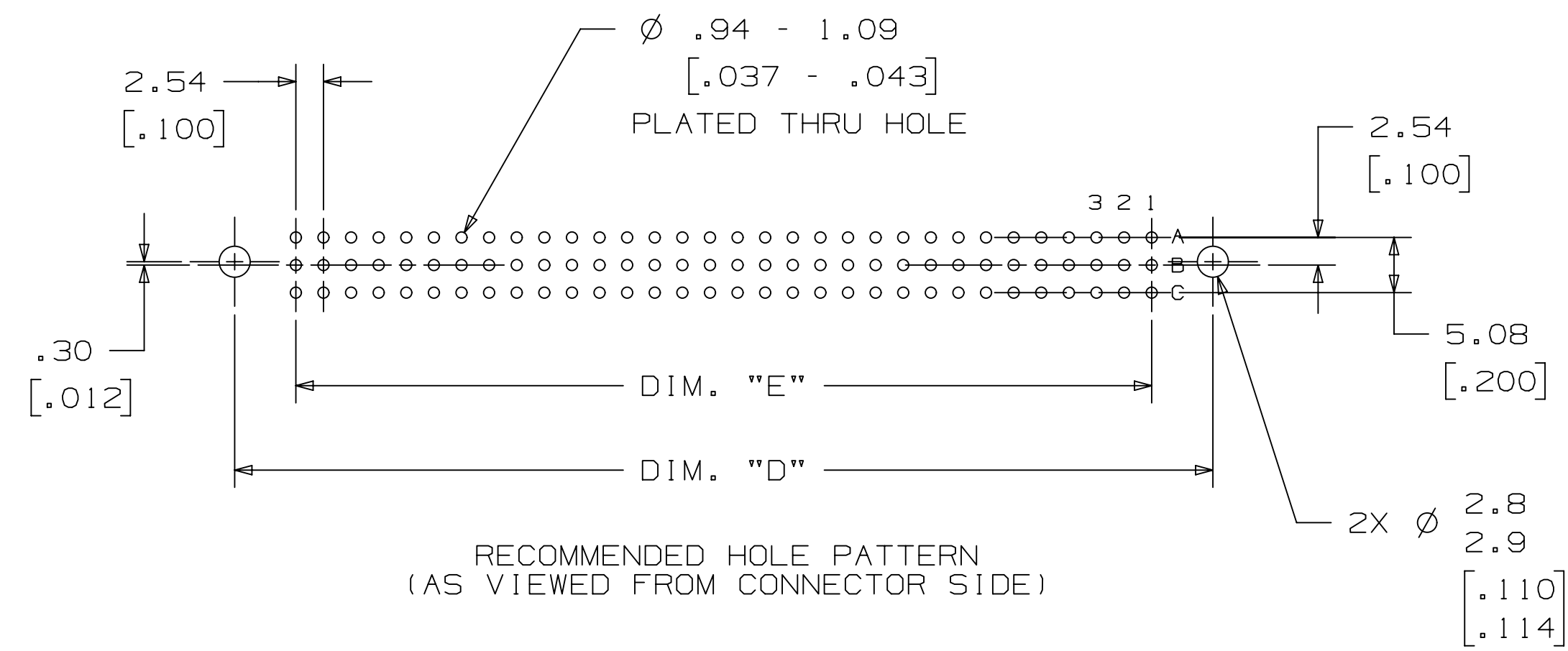
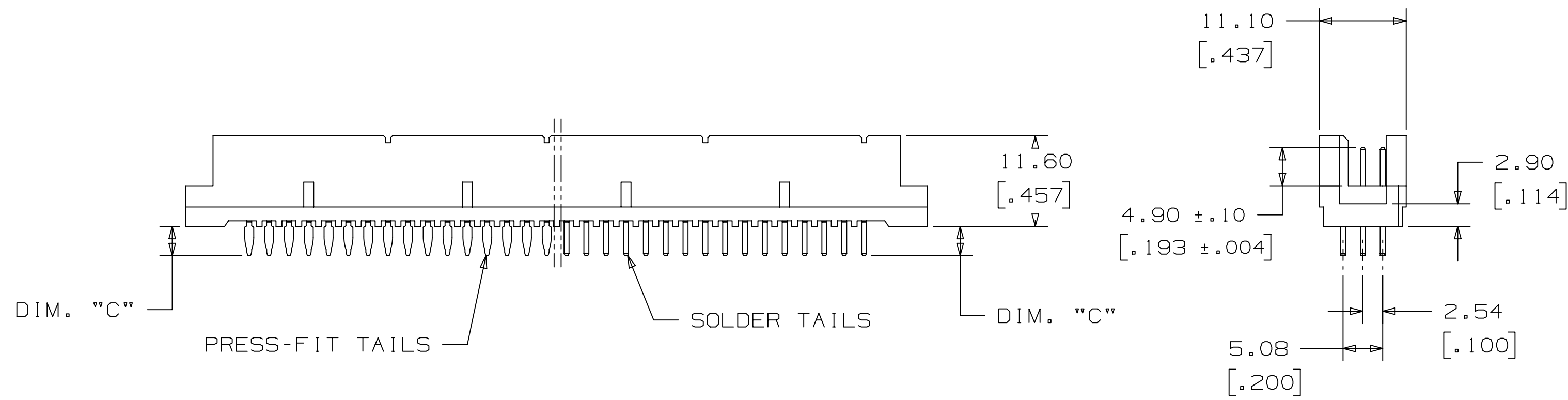
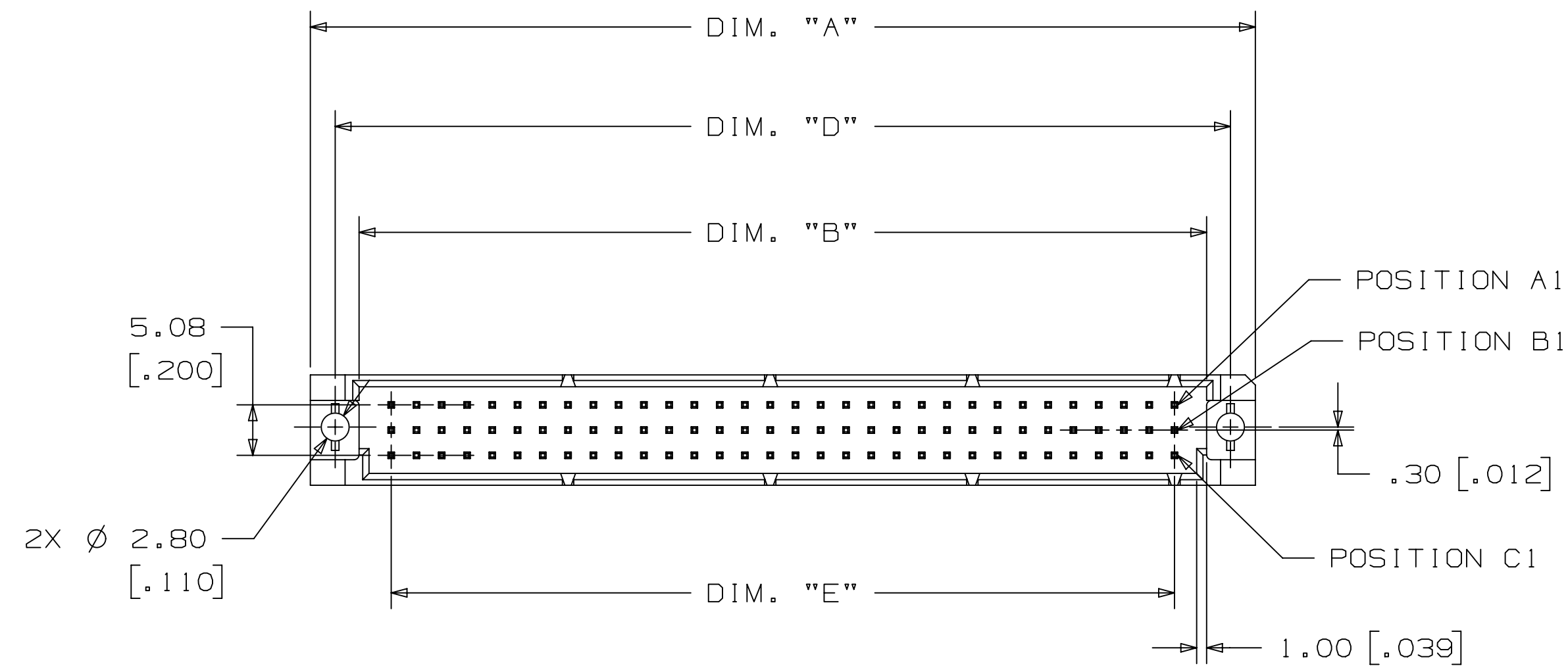

TABLE 1						
CONTACT QTY.	PART NUMBER	DIM. "A"	DIM. "B"	DIM. "D"	DIM. "E"	CONTACT QTY.
16	DIN-016RPA-XXX-XXXX	54.40 [2.142]	44.60 [1.756]	50.00 [1.969]	38.10 [1.500]	16
32	DIN-032RPB-XXX-XXXX	54.40 [2.142]	44.60 [1.756]	50.00 [1.969]	38.10 [1.500]	32
48	DIN-048RPC-XXX-XXXX	54.40 [2.142]	44.60 [1.756]	50.00 [1.969]	38.10 [1.500]	48
32	DIN-032RPD-XXX-XXXX	54.40 [2.142]	44.60 [1.756]	50.00 [1.969]	38.10 [1.500]	32
16	DIN-016RPE-XXX-XXXX	54.40 [2.142]	44.60 [1.756]	50.00 [1.969]	38.10 [1.500]	16
32	DIN-032RPA-XXX-XXXX	95.00 [3.740]	85.20 [3.354]	90.00 [3.543]	78.74 [3.100]	32
64	DIN-064RPB-XXX-XXXX	95.00 [3.740]	85.20 [3.354]	90.00 [3.543]	78.74 [3.100]	64
96	DIN-096RPC-XXX-XXXX	95.00 [3.740]	85.20 [3.354]	90.00 [3.543]	78.74 [3.100]	96
64	DIN-064RPD-XXX-XXXX	95.00 [3.740]	85.20 [3.354]	90.00 [3.543]	78.74 [3.100]	64
32	DIN-032RPE-XXX-XXXX	95.00 [3.740]	85.20 [3.354]	90.00 [3.543]	78.74 [3.100]	32
40	DIN-040RPA-XXX-XXXX	115.40 [4.543]	105.52 [4.154]	110.32 [4.343]	99.06 [3.900]	40
80	DIN-080RPB-XXX-XXXX	115.40 [4.543]	105.52 [4.154]	110.32 [4.343]	99.06 [3.900]	80
120	DIN-120RPC-XXX-XXXX	115.40 [4.543]	105.52 [4.154]	110.32 [4.343]	99.06 [3.900]	120
80	DIN-080RPD-XXX-XXXX	115.40 [4.543]	105.52 [4.154]	110.32 [4.343]	99.06 [3.900]	80
40	DIN-040RPE-XXX-XXXX	115.40 [4.543]	105.52 [4.154]	110.32 [4.343]	99.06 [3.900]	40

ORDERING INFORMATION
 R-FORM VERSION

DIN-XXXXRPX-XXX-XX

CONTACT QUANTITY:
 (SEE TABLE 1)

PLATING:

- A = A ROW ONLY (SEE NOTE)
- B = ROWS A & C FILLED
- C = ROWS A, B & C FILLED
- D = ROWS A & B FILLED
- E = B ROW ONLY (SEE NOTE)

- KR = 30-40μ" GOLD ON CONTACT AREA
 120-200μ" MATTE TIN ON TERMINAL
- HM = 3μ" GOLD ON CONTACT AREA, 7μ" MIN. PdNi
 120-200μ" MATTE TIN ON TERMINAL
- KV = 30μ" GOLD ON CONTACT AREA, 1-3μ" GOLD
 ON BOARD TERMINATION

TERMINATION OPTIONS:
 SEE TABLE 2

- NOTE:
- 1) A AND E OPTIONS ARE CURRENTLY NOT COVERED IN UL FILE NO. E68080.
 - 2) EARLY MATE LATE BREAK (EMLB) AND SELECTIVE LOADING OPTIONS AVAILABLE.
 - 3) MATES WITH C-FORM AND R-FORM SOCKETS.

THIS DIAGRAM SERVES ONLY FOR PART NUMBER DESCRIPTIVE DEFINITIONS.
 PLEASE CONTACT YOUR LOCAL SALES REPRESENTATIVE FOR CUSTOMER SPECIFIC
 PRODUCT CONFIGURATIONS.

TABLE 2		
SOLDER TERMINATION OPTION NO.	DIM. "C"	COMMENTS
R1	3.75 [.148]	WITH RETENTION CLIP
S1	3.75 [.148]	NO RETENTION CLIP
W	14.70 [.579]	NO RETENTION CLIP
PRESS-FIT TERMINATION OPTION NO.	DIM. "C"	COMMENTS
DPS	5.00 [.197]	
DPW1	13.25 [.522]	

C	97226	MAY 25, 2021	JNC	SAN
B	73823	MAY 30, 2017	JNC	WL
A	72454	FEB 24, 2017	JNC	WL

DESIGN REFERENCE	NEXT ASSEMBLY	REV	ECO	ISSUE DATE AND DESCRIPTION	DRFT	CHKD
APPROVED		CASTIGLIONE		FEB 20, 2017		
DIVISION	DIVISION CODE	DATE	DATE	DATE	DATE	DATE
DO NOT SCALE DRAWING	SCALE 2/1	TOLERANCES EXCEPT AS NOTED				
THIRD ANGLE PROJECTION	INTERPRET PER ASME Y14.5 - 2018	MAX. SURFACE ROUGHNESS	TITLE: DIN C & R-FORM PLUG, RA, VERT, SOLDER TAIL OR PRESS-FIT CAGE NUMBER: D78-5100-2671-5 MODEL:			
MARKED ONLY	ANGLES	DET: [] YES [X] NO SHT 3 OF 5				

78-5100-2671-5
 DRAWING NUMBER

A

3M™ DIN C-FORM & R-FORM PLUG, DIN 41612 SERIES
 VERTICAL, RIGHT ANGLE, SOLDER TAIL OR PRESS-FIT TERMINATION, .100" BACKPLANE REAR PLUG

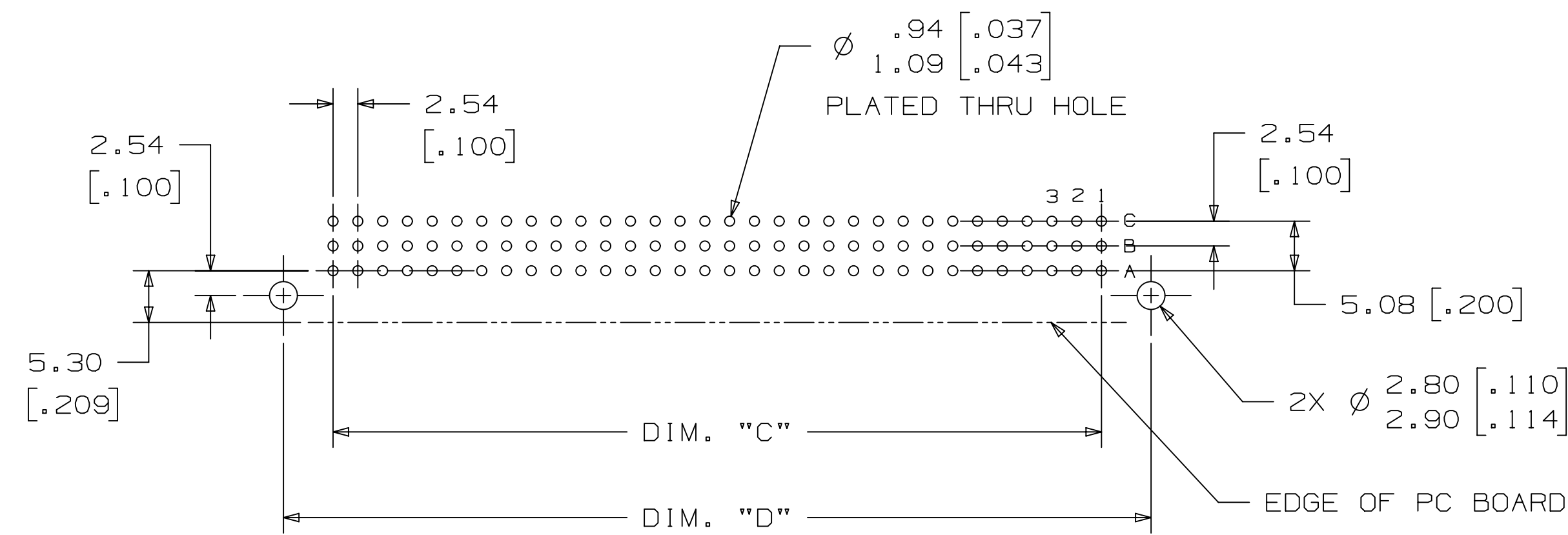
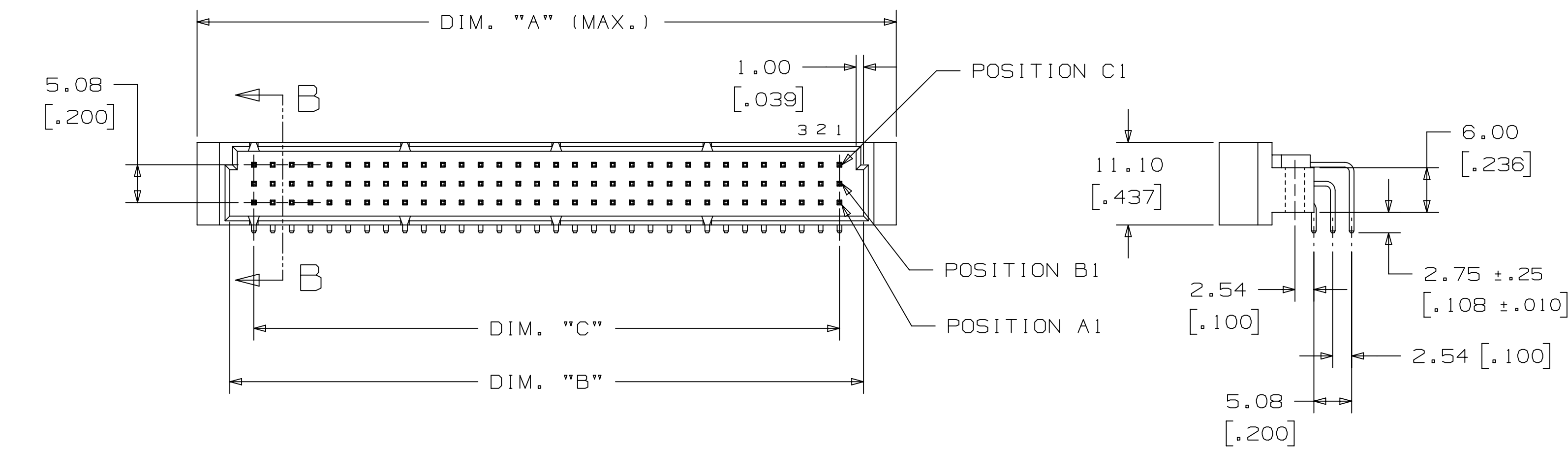
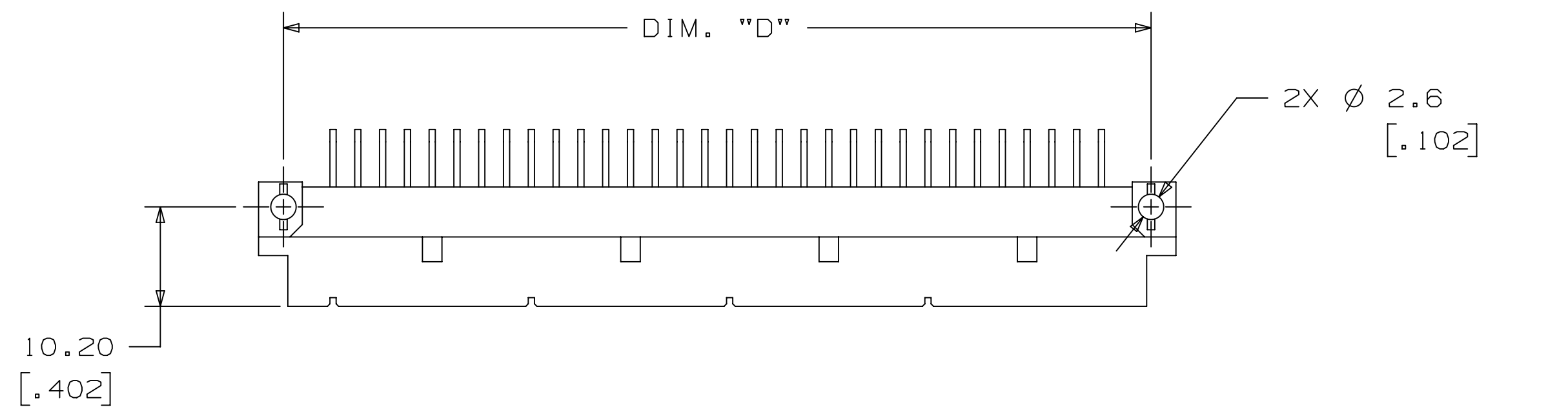

RECOMMENDED HOLE PATTERN
 (AS VIEWED FROM CONNECTOR SIDE)

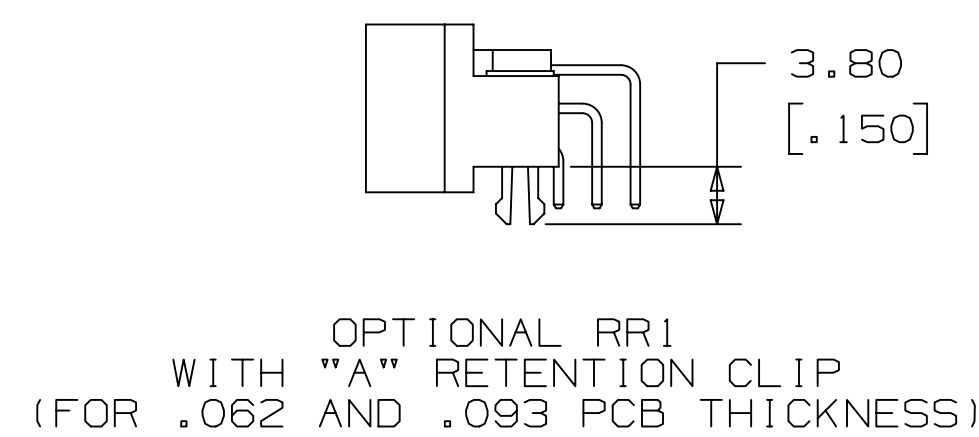
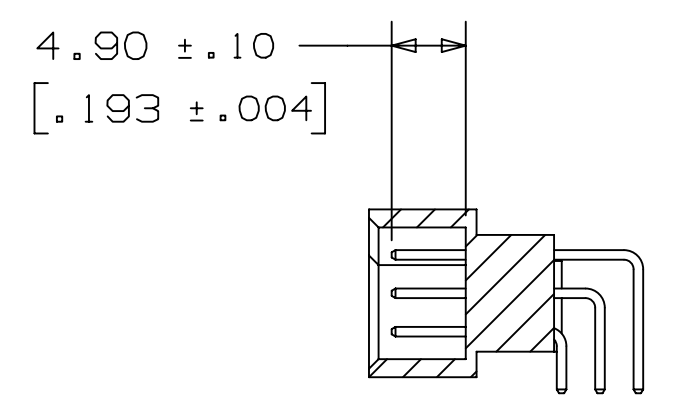

OPTION SR1 WITHOUT RETENTION CLIP

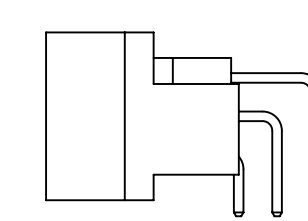

OPTIONAL RRIL WITH 'B' RETENTION CLIP (FOR .062 PCB THICKNESS)

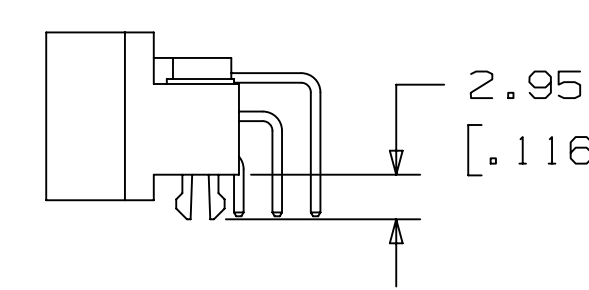

TABLE 1						
CONTACT QTY.	PART NUMBER	DIM. "A"	DIM. "B"	DIM. "C"	DIM. "D"	CONTACT QTY.
16	DIN-016CPA-XXX-XXXX	54.40 [2.142]	44.56 [1.754]	38.10 [1.500]	48.26 [1.900]	16
32	DIN-032CPB-XXX-XXXX	54.40 [2.142]	44.56 [1.754]	38.10 [1.500]	48.26 [1.900]	32
48	DIN-048CPC-XXX-XXXX	54.40 [2.142]	44.56 [1.754]	38.10 [1.500]	48.26 [1.900]	48
32	DIN-032CPD-XXX-XXXX	54.40 [2.142]	44.56 [1.754]	38.10 [1.500]	48.26 [1.900]	32
16	DIN-016CPE-XXX-XXXX	54.40 [2.142]	44.56 [1.754]	38.10 [1.500]	48.26 [1.900]	16
32	DIN-032CPA-XXX-XXXX	94.00 [3.701]	85.20 [3.354]	78.74 [3.100]	88.90 [3.500]	32
64	DIN-064CPB-XXX-XXXX	94.00 [3.701]	85.20 [3.354]	78.74 [3.100]	88.90 [3.500]	64
96	DIN-096CPC-XXX-XXXX	94.00 [3.701]	85.20 [3.354]	78.74 [3.100]	88.90 [3.500]	96
64	DIN-064CPD-XXX-XXXX	94.00 [3.701]	85.20 [3.354]	78.74 [3.100]	88.90 [3.500]	64
32	DIN-032CPE-XXX-XXXX	94.00 [3.701]	85.20 [3.354]	78.74 [3.100]	88.90 [3.500]	32

ORDERING INFORMATION
 C-FORM VERSION

DIN-XXXCPX-XXX-XX

CONTACT QUANTITY:
 (SEE TABLE 1)

PLATING:

KR = 30-40µ" GOLD ON CONTACT AREA
 120-200µ" MATTE TIN ON TERMINAL
 HM = 3µ" GOLD ON CONTACT AREA, 7µ" MIN. PdNi
 120-200µ" MATTE TIN ON TERMINAL

A = A ROW ONLY (SEE NOTE)
 B = ROWS A & C FILLED
 C = ROWS A, B & C FILLED
 D = ROWS A & B FILLED
 E = B ROW ONLY (SEE NOTE)

TERMINATION OPTIONS:
 SOLDER TAIL TERMINATION
 SR1 = .275 [.108]
 RRIL = 2.75 [.108] WITH 'B' RETENTION CLIP
 RRI = 2.75 [.108] WITH 'A' RETENTION CLIP

NOTE:
 1) A AND E OPTIONS ARE CURRENTLY NOT COVERED IN UL FILE NO. E68080.
 2) EARLY MATE LATE BREAK (EMLB) OPTIONS AVAILABLE.
 3) MATES WITH C-FORM AND R-FORM SOCKETS.

THIS DIAGRAM SERVES ONLY FOR PART NUMBER DESCRIPTIVE DEFINITIONS.
 PLEASE CONTACT YOUR LOCAL SALES REPRESENTATIVE FOR CUSTOMER SPECIFIC
 PRODUCT CONFIGURATIONS.

REV	ECO	ISSUE DATE AND DESCRIPTION	DRFT	CHKD
C	97226	MAY 25, 2021 REVISED INSULATION RESISTANCE	JNC	SAN
B	73823	MAY 30, 2017 REMOVE PLATING SH & FJ	JNC	WL
A	72454	FEB 24, 2017 PRODUCTION RELEASE	JNC	WL

DESIGN REFERENCE	NEXT ASSEMBLY	REV	ECO	ISSUE DATE AND DESCRIPTION	DRFT	CHKD
		DRFT	CASTIGLIONE	FEB 20, 2017	MFG	DATE
		CHKD		DATE	APPLY	DATE
					W. LEE	FEB 20, 2017
DIVISION	DIVISION CODE	© 3M COPYRIGHT 2021 This document and the information it contains are 3M property and may not be reproduced or further distributed without 3M permission, or used or disclosed other than for 3M authorized purposes. All rights reserved.				
DO NOT SCALE DRAWING	SCALE 2/1	TOLERANCES EXCEPT AS NOTED	INCHES .00 ± .008 ± .0000 ±			
THIRD ANGLE PROJECTION	INTERPRET PER ASME Y14.5 - 2018	MILLIMETERS	0 ± .00 ± .000 ±			
MAX SURFACE ROUGHNESS	MARKED ONLY	ANGLES	CAGE NUMBER D 78-5100-2671-5 MODEL			

TITLE	DIN C & R-FORM PLUG, RA, VERT, SOLDER TAIL OR PRESS-FIT
CAGE NUMBER	D 78-5100-2671-5
SIZE	C
DRAWING NO.	78-5100-2671-5
REV.	C
DET	ISTS
YES	NO
SHT	4 OF 5