

# 3M™ DIN C-FORM & R-FORM SOCKET, DIN 41612 SERIES

VERTICAL, RIGHT ANGLE, SOLDER TAIL OR PRESS-FIT TERMINATION

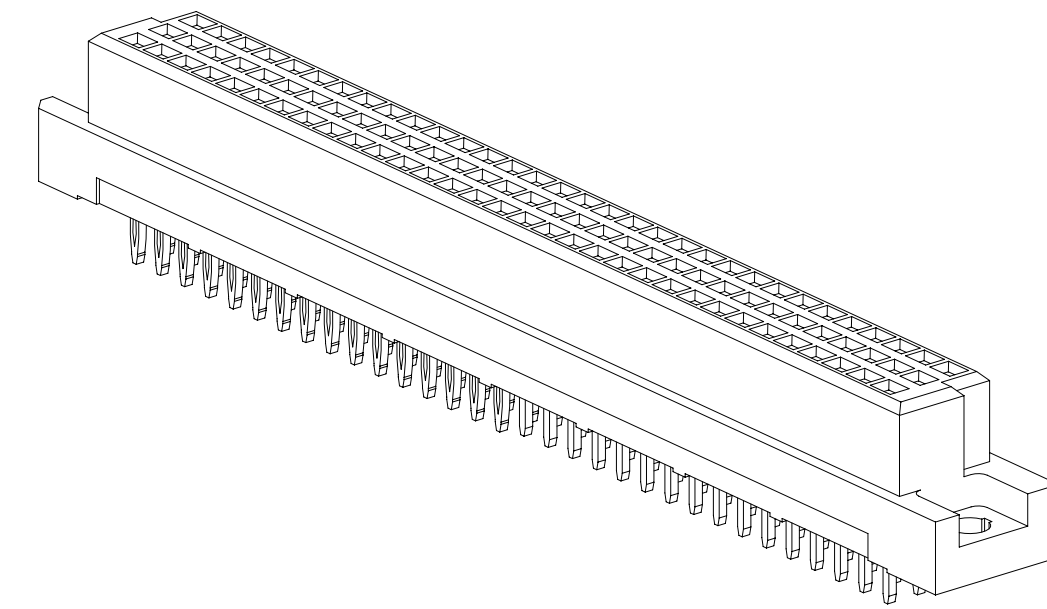

DIN-XXXCSX-XXX  
VERTICAL VERSION

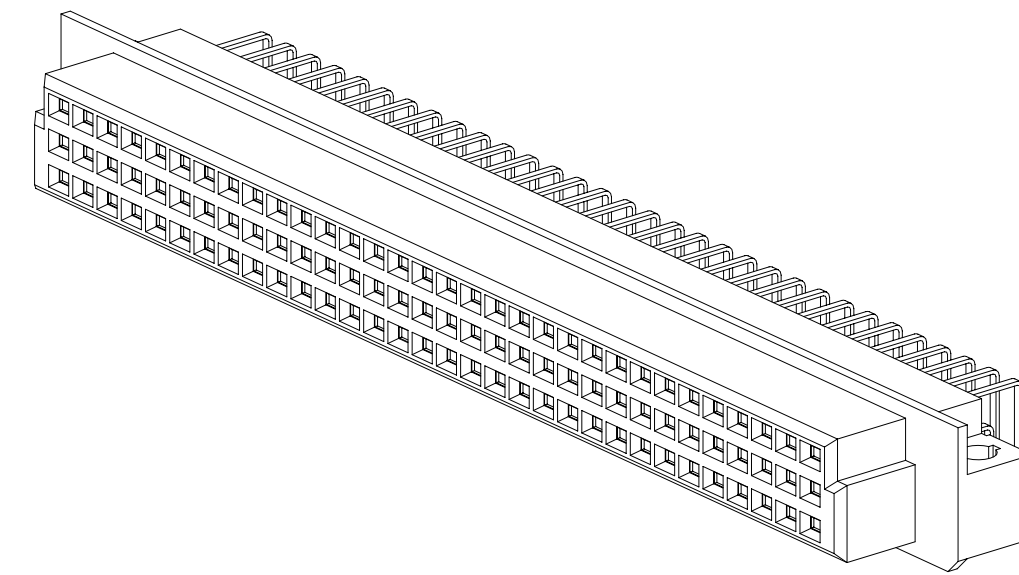

DIN-XXXRSX-XXX  
RIGHT ANGLE VERSION

## 2 PHYSICAL :

INSULATOR: GLASS FILLED POLYESTER (PBT)  
 MATERIAL: UL94V-0  
 FLAMMABILITY: UL94V-0  
 COLOR: GRAY  
 CONTACT: COPPER ALLOY  
 MATERIAL: COPPER ALLOY  
 PLATING: 50μ" MIN. NICKEL  
 UNDER PLATING: SEE ORDERING INFORMATION  
 WIPING AREA: SEE ORDERING INFORMATION  
 TERMINATION AREA: SEE ORDERING INFORMATION

## 2 ELECTRICAL :

CURRENT RATING: 3.0A AT 30°C T-RISE ABOVE AMBIENT  
 CONTACT RESISTANCE: ≤20mΩ  
 INSULATION RESISTANCE: ≥1,000 MΩ, 100 V<sub>DC</sub>  
 WITHSTANDING VOLTAGE: 1,000V<sub>AC</sub> FOR 1 MINUTE

## 2 ENVIRONMENTAL :

TEMPERATURE RATING: -55°C TO 125°C  
 PROCESS TEMPERATURE RATING: MAX. INSULATOR TEMPERATURE 191°C  
 (SOLDER WAVE PROCESS ONLY)

- NOTES
- REGULATORY INFORMATION: VISIT 3M.com/regs OR CONTACT YOUR 3M REPRESENTATIVE TO FIND THE RoHS COMPLIANCE STATUS OF THE 3M PART YOU ARE INTERESTED IN.
  - IN THE EVENT OF CONFLICT BETWEEN THIS DATA AND THAT CONTAINED IN THE PRODUCT SPECIFICATION, THE PRODUCT SPECIFICATION TAKES PRECEDENT.

DIMENSIONS: MM [ INCHES ]  
 [ INCHES ] IS REF. ONLY

3M ELECTRONICS MATERIALS SOLUTIONS DIVISION  
 INTERCONNECT SOLUTIONS  
<http://www.3mconnectors.com>

3M IS A TRADEMARK OF 3M COMPANY.  
 FOR TECHNICAL, SALES OR ORDERING  
 INFORMATION CALL 800-225-5373

MM [ INCH ]			
TOLERANCE - UNLESS NOTED			
	X.	.X	.XX
MM	±.50	±.25	±.15
[ INCH ]	±.020	±.010	±.006
[ ] = DIM. FOR REFERENCE ONLY			



UL FILE NO: E68080

DESIGN REFERENCE	NEXT ASSEMBLY	REV	ECO	ISSUE DATE AND DESCRIPTION	DRFT	CHKD
DRY CODES		DRFT	ECO	DATE	MFG	DATE
		CASTIGLIONE		FEB 20,2017		
DIVISION	DIVISION CODE	CHKD	DATE	APPRV	DATE	
	EMSD			W. LEE	FEB 20,2017	
DO NOT SCALE DRAWING	SCALE 2/1	TOLERANCES EXCEPT AS NOTED		© 3M COPYRIGHT 2017 This document and the information it contains are 3M property and may not be reproduced or further distributed without 3M permission, or used or disclosed other than for 3M authorized purposes. All rights reserved.		
THIRD ANGLE PROJECTION		INCHES		TITLE DIN C & R-FORM SKT, RA, VERT, SOLDER TAIL OR PRESS-FIT		
INTERPRET PER ASME Y14.5 - 2009		MILLIMETERS		CAGE NUMBER D 78-5100-2670-7		
MAX SURFACE ROUGHNESS		INCHES		DRAWING NO. 78-5100-2670-7		
DTX SURFACES		MILLIMETERS		REV. B		
MARKED ONLY		ANGLES		MODEL SHT 1 OF 4		

78-5100-2670-7  
DRAWING NUMBER  
REV B  
Imaged: B.1 Central Standard Time 5/30/2017 UTC OffSet

# 3M™ DIN C-FORM & R-FORM SOCKET, DIN 41612 SERIES

VERTICAL, RIGHT ANGLE, SOLDER TAIL OR PRESS-FIT TERMINATION

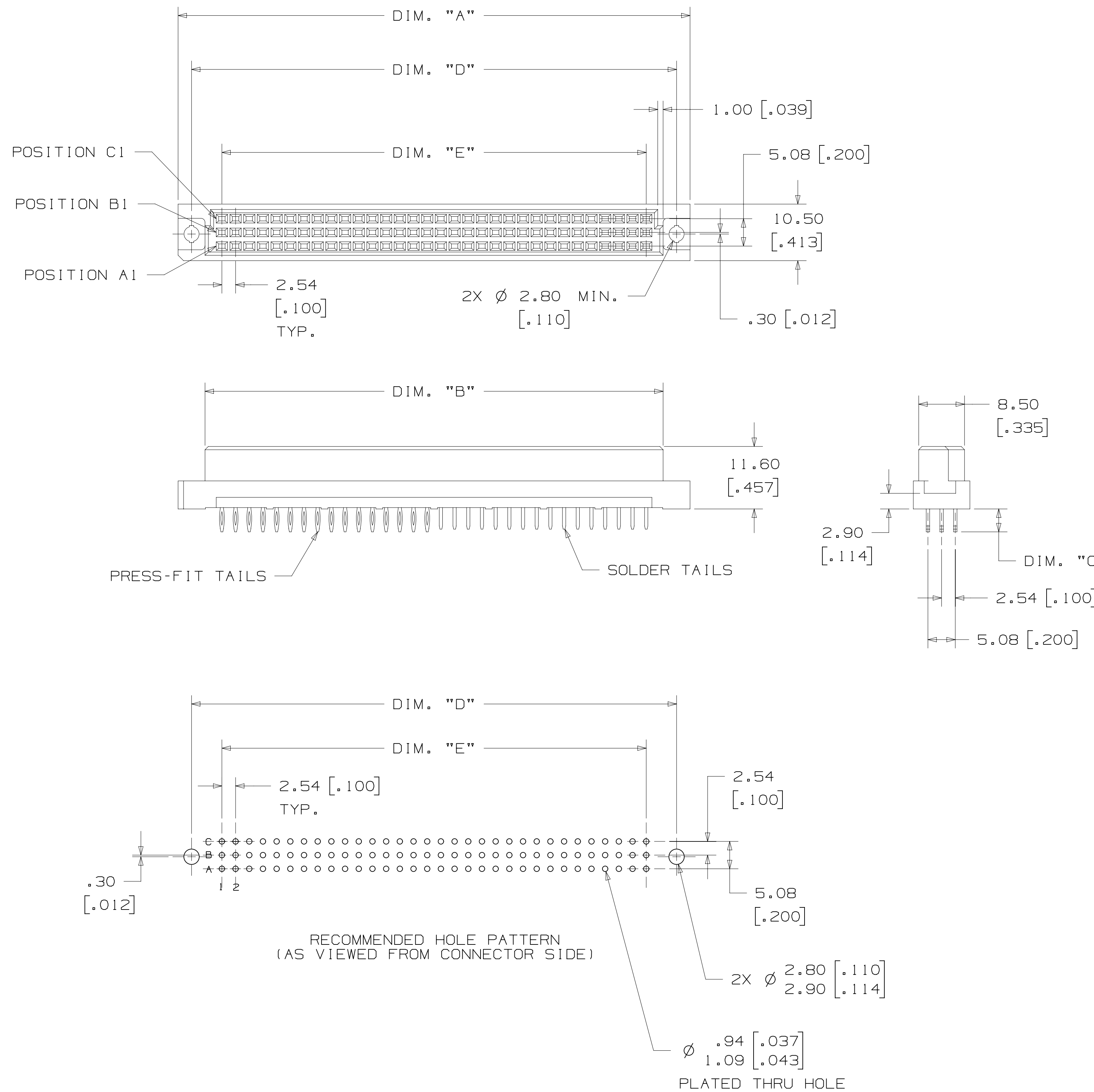

CONTACT QTY.	PART NUMBER	DIM. "A"	DIM. "B"	DIM. "D"	DIM. "E"	CONTACT QTY.
16	DIN-016CSA-XXX-XXXX	54.40 [ 2.142 ]	44.40 [ 1.748 ]	50.00 [ 1.969 ]	38.10 [ 1.500 ]	16
32	DIN-032CSB-XXX-XXXX	54.40 [ 2.142 ]	44.40 [ 1.748 ]	50.00 [ 1.969 ]	38.10 [ 1.500 ]	32
48	DIN-048CSC-XXX-XXXX	54.40 [ 2.142 ]	44.40 [ 1.748 ]	50.00 [ 1.969 ]	38.10 [ 1.500 ]	48
32	DIN-032CSD-XXX-XXXX	54.40 [ 2.142 ]	44.40 [ 1.748 ]	50.00 [ 1.969 ]	38.10 [ 1.500 ]	32
16	DIN-016CSE-XXX-XXXX	54.40 [ 2.142 ]	44.40 [ 1.748 ]	50.00 [ 1.969 ]	38.10 [ 1.500 ]	16
32	DIN-032CSA-XXX-XXXX	95.00 [ 3.740 ]	85.00 [ 3.346 ]	90.00 [ 3.543 ]	78.74 [ 3.100 ]	32
64	DIN-064CSB-XXX-XXXX	95.00 [ 3.740 ]	85.00 [ 3.346 ]	90.00 [ 3.543 ]	78.74 [ 3.100 ]	64
96	DIN-096CSC-XXX-XXXX	95.00 [ 3.740 ]	85.00 [ 3.346 ]	90.00 [ 3.543 ]	78.74 [ 3.100 ]	96
64	DIN-064CSD-XXX-XXXX	95.00 [ 3.740 ]	85.00 [ 3.346 ]	90.00 [ 3.543 ]	78.74 [ 3.100 ]	64
32	DIN-032CSE-XXX-XXXX	95.00 [ 3.740 ]	85.00 [ 3.346 ]	90.00 [ 3.543 ]	78.74 [ 3.100 ]	32

## ORDERING INFORMATION C-FORM VERSION

DIN-XXXCSX-XXX-XX

CONTACT QUANTITY: (SEE TABLE 1)

- A = A ROW ONLY (SEE NOTE)
- B = ROWS A & C FILLED
- C = ROWS A, B & C FILLED
- D = ROWS A & B FILLED
- E = B ROW ONLY (SEE NOTE)

PLATING:

- KR = 30-40 $\mu$ " GOLD ON CONTACT AREA, 120-200 $\mu$ " MATTE TIN ON TERMINAL
- HM = 3 $\mu$ " GOLD ON CONTACT AREA, 7 $\mu$ " MIN. PdNi, 120-200 $\mu$ " MATTE TIN ON TERMINAL
- KV = 30 $\mu$ " GOLD ON CONTACT AREA, 1-3 $\mu$ " GOLD ON BOARD TERMINATION

TERMINATION OPTIONS: SEE TABLE 2

NOTE:

- 1) A AND E OPTIONS ARE CURRENTLY NOT COVERED IN UL FILE NO. E68080.
- 2) MATES WITH C-FORM AND R-FORM PLUGS.

SOLDER TERMINATION OPTION NO.	DIM. "C"	COMMENTS
R1L	3.75 [ .148 ]	WITH RETENTION CLIP
R3L	2.29 [ .090 ]	WITH RETENTION CLIP
S1L	3.75 [ .148 ]	NO RETENTION CLIP
S3L	2.29 [ .090 ]	NO RETENTION CLIP
W	14.70 [ .579 ]	NO RETENTION CLIP
PRESS-FIT TERMINATION OPTION NO.	DIM. "C"	COMMENTS
PS	5.99 [ .236 ]	
PSL	4.25 [ .167 ]	
PW1	12.90 [ .508 ]	

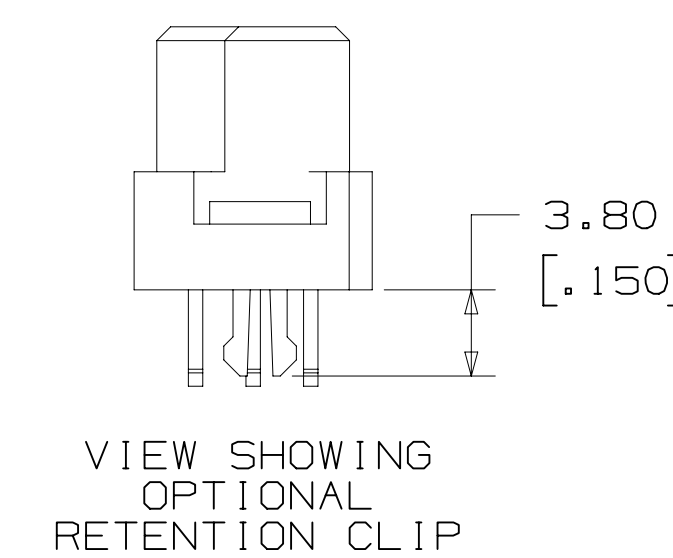

REV	ECO	ISSUE DATE AND DESCRIPTION	DRFT	CHKD
B	73823	MAY 30, 2017 REMOVE PLATING SH & FJ	JNC	WL
A	72454	FEB 24, 2017 PRODUCTION RELEASE	JNC	WL
CHKD	DATE	DATE	DATE	DATE
CASTIGLIONE	FEB 20, 2017	MFG		
DATE	DATE	DATE	DATE	DATE
W. LEE	FEB 20, 2017			

DIVISION: EMSD  
 SCALE: 2/1  
 TOLERANCES EXCEPT AS NOTED:  
 INCHES: .00, .000, .0000  
 MILLIMETERS: 0, .00, .000, .0000  
 MAX SURFACE ROUGHNESS: 0.40, 0.20, 0.10  
 SURFACES: 0.40, 0.20, 0.10  
 MARKED ONLY:

TITLE: DIN C & R-FORM SKT, RA, VERT, SOLDER TAIL OR PRESS-FIT  
 CAGE NUMBER: D78-5100-2670-7  
 MODEL:  YES  NO SHT 2 OF 4

78-5100-2670-7 REV. B DRAWING NUMBER  
Standard Time5/30/2017UTC Offset  
Imaged: B.1 Central

# 3M™ DIN C-FORM & R-FORM SOCKET, DIN 41612 SERIES

VERTICAL, RIGHT ANGLE, SOLDER TAIL OR PRESS-FIT TERMINATION

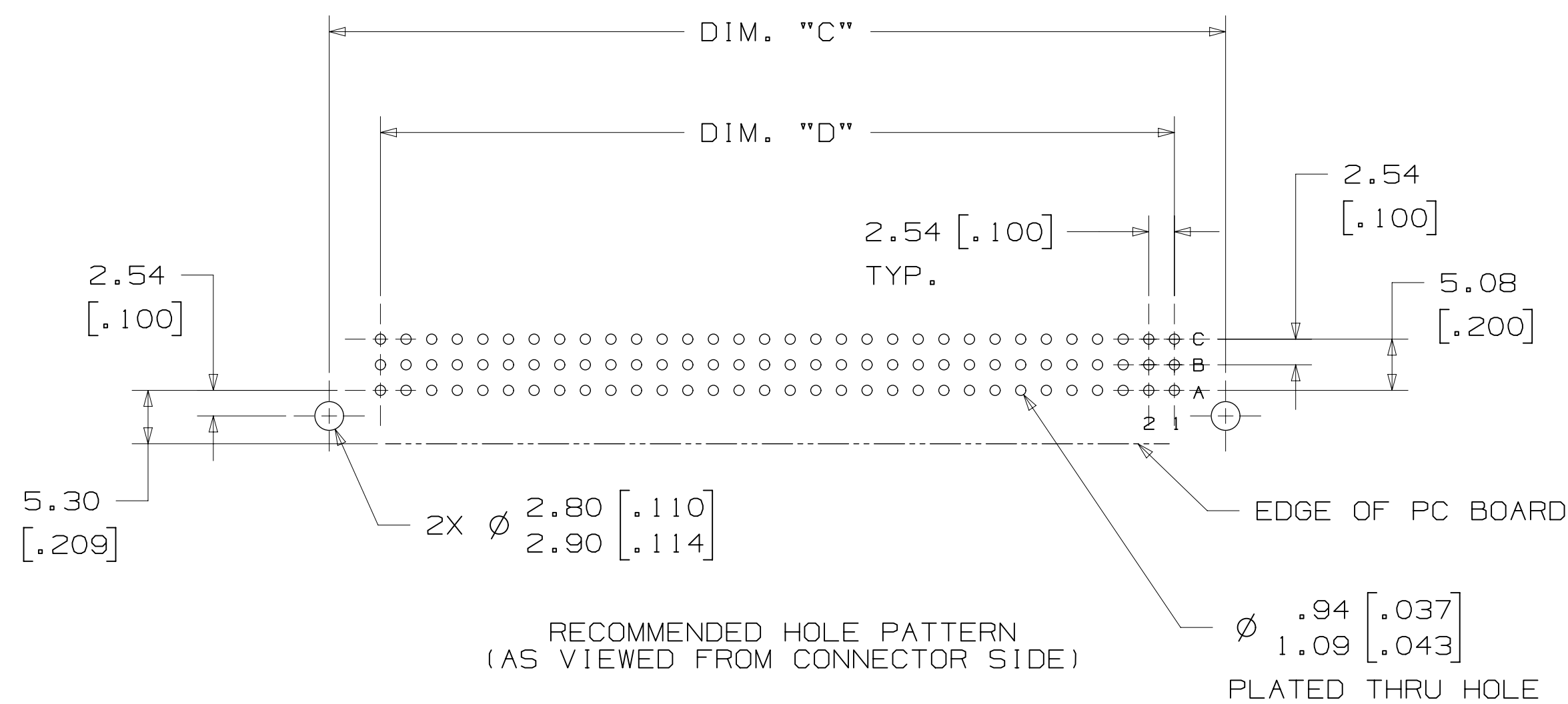
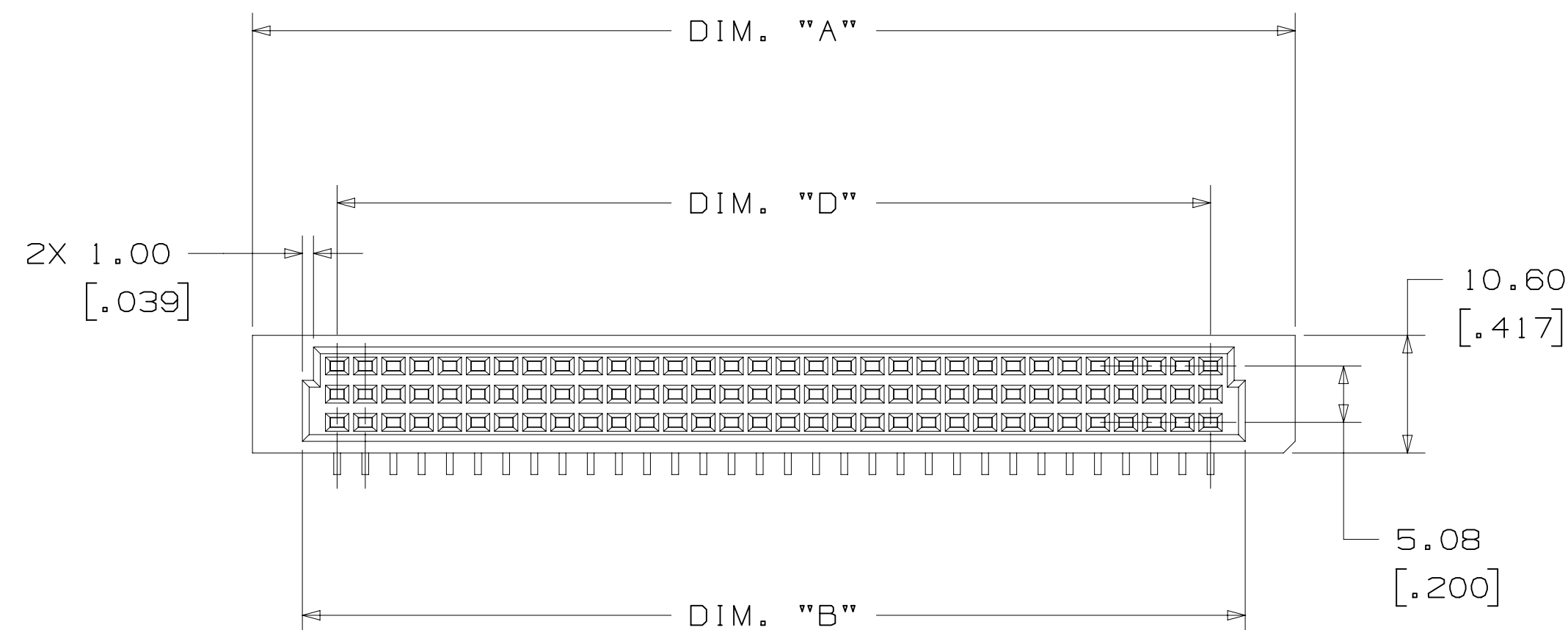
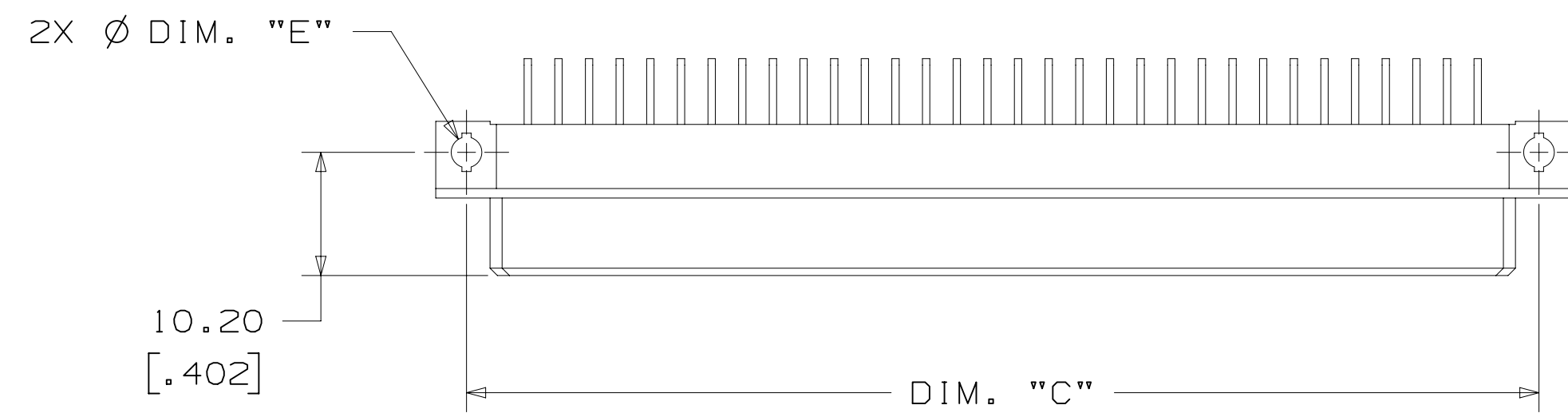
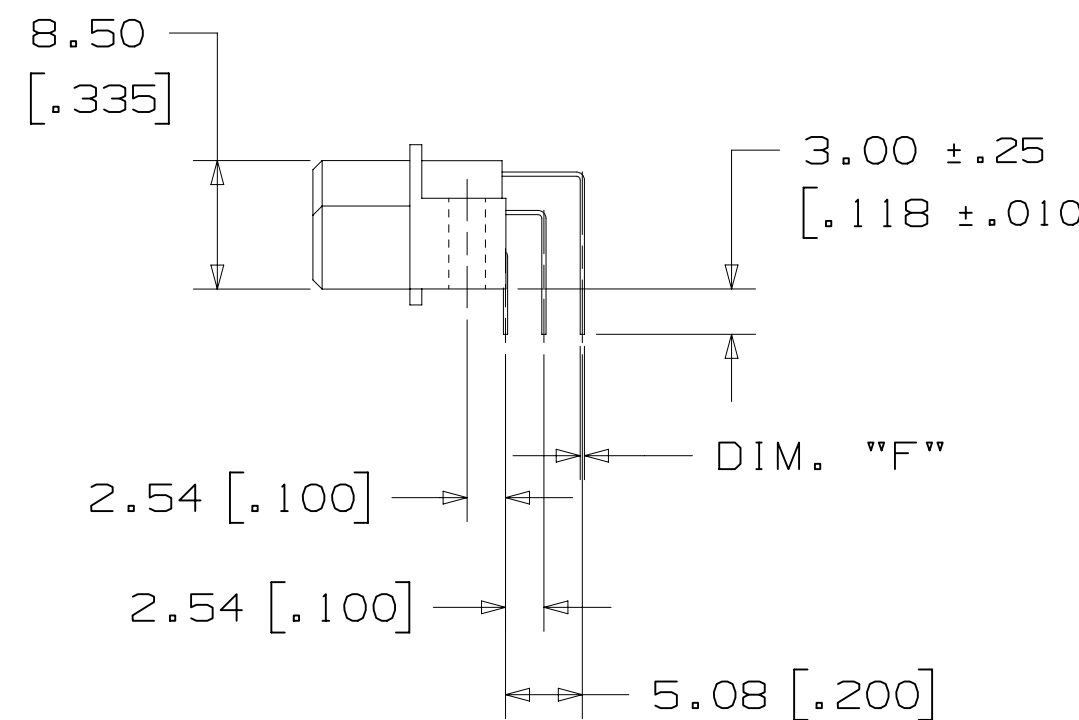

TABLE 1								
CONTACT QTY.	PART NUMBER	DIM. "A"	DIM. "B"	DIM. "C"	DIM. "D"	DIM. "E"	DIM. "F"	CONTACT QTY.
16	DIN-016RSA-XXX-XXXX	53.40 [2.102]	44.40 [1.748]	48.26 [1.900]	38.10 [1.500]	Ø2.60 [.102]	.25 [.010]	16
32	DIN-032RSB-XXX-XXXX	53.40 [2.102]	44.40 [1.748]	48.26 [1.900]	38.10 [1.500]	Ø2.60 [.102]	.25 [.010]	32
48	DIN-048RSC-XXX-XXXX	53.40 [2.102]	44.40 [1.748]	48.26 [1.900]	38.10 [1.500]	Ø2.60 [.102]	.25 [.010]	48
32	DIN-032RSD-XXX-XXXX	53.40 [2.102]	44.40 [1.748]	48.26 [1.900]	38.10 [1.500]	Ø2.60 [.102]	.25 [.010]	32
16	DIN-016RSE-XXX-XXXX	53.40 [2.102]	44.40 [1.748]	48.26 [1.900]	38.10 [1.500]	Ø2.60 [.102]	.25 [.010]	16
32	DIN-032RSA-XXX-XXXX	94.00 [3.701]	85.00 [3.346]	88.90 [3.500]	78.74 [3.100]	Ø2.60 [.102]	.25 [.010]	32
64	DIN-064RSB-XXX-XXXX	94.00 [3.701]	85.00 [3.346]	88.90 [3.500]	78.74 [3.100]	Ø2.60 [.102]	.25 [.010]	64
96	DIN-096RSC-XXX-XXXX	94.00 [3.701]	85.00 [3.346]	88.90 [3.500]	78.74 [3.100]	Ø2.60 [.102]	.25 [.010]	96
64	DIN-064RSD-XXX-XXXX	94.00 [3.701]	85.00 [3.346]	88.90 [3.500]	78.74 [3.100]	Ø2.60 [.102]	.25 [.010]	64
32	DIN-032RSE-XXX-XXXX	94.00 [3.701]	85.00 [3.346]	88.90 [3.500]	78.74 [3.100]	Ø2.60 [.102]	.25 [.010]	32
40	DIN-040RSA-XXX-XXXX	114.32 [4.501]	105.32 [4.146]	109.22 [4.300]	99.06 [3.900]	Ø2.80 [.110]	.60 [.024]	40
80	DIN-080RSB-XXX-XXXX	114.32 [4.501]	105.32 [4.146]	109.22 [4.300]	99.06 [3.900]	Ø2.80 [.110]	.60 [.024]	80
120	DIN-120RSC-XXX-XXXX	114.32 [4.501]	105.32 [4.146]	109.22 [4.300]	99.06 [3.900]	Ø2.80 [.110]	.60 [.024]	120
80	DIN-080RSD-XXX-XXXX	114.32 [4.501]	105.32 [4.146]	109.22 [4.300]	99.06 [3.900]	Ø2.80 [.110]	.60 [.024]	80
40	DIN-040RSE-XXX-XXXX	114.32 [4.501]	105.32 [4.146]	109.22 [4.300]	99.06 [3.900]	Ø2.80 [.110]	.60 [.024]	40



## ORDERING INFORMATION R-FORM VERSION

DIN-XXXRSX-XXX-XX

CONTACT QUANTITY:  
(SEE TABLE 1)

- A = A ROW ONLY (SEE NOTE)
- B = ROWS A & C FILLED
- C = ROWS A, B & C FILLED
- D = ROWS A & B FILLED
- E = B ROW ONLY (SEE NOTE)

TERMINATION OPTIONS:  
SR1 = 3.00 [.118]  
RR1L = 3.00 [.118] WITH 'B' RETENTION CLIPS

PLATING:

- KR = 30-40µ" GOLD ON CONTACT AREA
- 120-200µ" MATTE TIN ON TERMINAL
- HM = 3µ" GOLD ON CONTACT AREA, 7µ" MIN. PdNi
- 120-200µ" MATTE TIN ON TERMINAL

- NOTE:
- 1) A AND E OPTIONS ARE CURRENTLY NOT COVERED IN UL FILE NO. E68080.
  - 2) MATES WITH C-FORM AND R-FORM PLUGS.

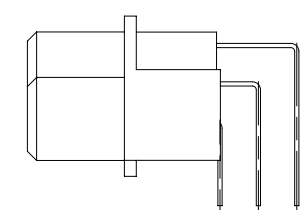

SR1  
WITHOUT OPTIONAL  
RETENTION CLIPS

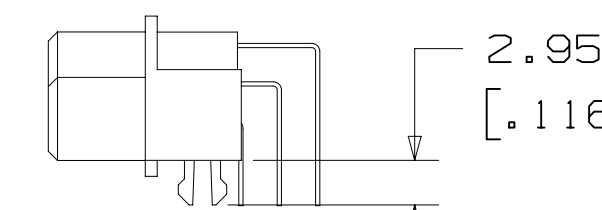

RR1L  
WITH "B" OPTIONAL RETENTION  
CLIPS FOR .062 PCB THICKNESS

DESIGN REFERENCE	NEXT ASSEMBLY	REV	ECO	ISSUE DATE AND DESCRIPTION	DRFT	CHKD
		B	73823	MAY 30, 2017 REMOVE PLATING SH & FJ	JNC	WL
		A	72454	FEB 24, 2017 PRODUCTION RELEASE	JNC	WL
DO NOT SCALE DRAWING	SCALE 2/1	DRFT	CHKD	DATE	DATE	DATE
THIRD ANGLE PROJECTION	INTERPRET PER ASME Y14.5 - 2009	CASTIGLIONE	W. LEE	FEB 20, 2017	FEB 20, 2017	FEB 20, 2017
MAX SURFACE ROUGHNESS	MARKED ONLY	DIVISION CODE: EMSD TOLERANCES EXCEPT AS NOTED: INCHES: .00, .000, .0000 MILLIMETERS: 0, .00, .000, .0000 ANGLE:				
CAGE NUMBER: D78-5100-2670-7 MODEL:		© 3M COPYR[IGHT] 2017 This document and the information it contains are 3M property and may not be reproduced or further distributed without 3M permission, or used or disclosed other than for 3M authorized purposes. All rights reserved.				
TITLE: DIN C & R-FORM SKT, RA, VERT, SOLDER TAIL OR PRESS-FIT		CAGE NUMBER: D78-5100-2670-7 MODEL:				
DET:		SHT 3 OF 4				