

# DIO207x

## Single/Dual/Quad/Six channel, RRIO 10MHz Amplifier

### Features

- Rail-to-Rail Input and Output
- $\pm 3\text{mV}$  Typical offset ( $V_{OS}$ )
- Low Distortion
- Gain Bandwidth Product: 10MHz
- Wide supply range: 3.0V to 5.5V
- 3mA/Amplifier typical supply current
- Slew rate: 4.0V/ $\mu\text{s}$
- DIO2071 available in SOT23-5  
DIO2072 available in SOIC-8, MSOP-8 and TSSOP-8  
DIO2074 available in SOIC-14, QFN-16  
DIO2076 available in SOIC-20, QFN-28

### Applications

- Portable Equipment
- Active Filters
- Data Acquisition
- Portable Equipment
- Test Equipment
- Broadband Communication
- Process Control
- Audio and Video Processing

### Ordering Information

Order Part Number	Top Marking		$T_A$		Package
DIO2071ST5	YW(X)Z	Green/RoHS	-40 to +125°C	SOT23-5	Tape & Reel, 3000
DIO2072MP8	DIO2072	Green/RoHS	-40 to +125°C	MSOP-8	Tape & Reel, 3000
DIO2072SO8	DIO2072	Green/RoHS	-40 to +125°C	SOIC-8	Tape & Reel, 2500
DIO2072TP8	DIO2072	Green/RoHS	-40 to +125°C	TSSOP-8	Tape & Reel, 2500
DIO2074CS14	DIO2074	Green/RoHS	-40 to +125°C	SOIC-14	Tape & Reel, 2500
DIO2074CN16	D2074	Green/RoHS	-40 to +125°C	QFN-16	Tape & Reel, 5000
DIO2076CS20	DIO2076	Green/RoHS	-40 to +125°C	SOIC-20	Tape & Reel, 2500
DIO2076CL28	D2076	Green/RoHS	-40 to +125°C	QFN-28	Tape & Reel, 5000

### Descriptions

The DIO207x is a single/dual/quad/six channel, rail-to-rail I/O operational amplifier which allows low load impedances to be driven. With a 10MHz unity-gain frequency and low noise, low distortion and high output current capability, the DIO207x provides excellent choice for high quality systems. The input common-mode voltage range includes ground, and the maximum input offset voltage is  $\pm 3\text{mV}$  (guaranteed). They are also capable of comfortably driving large capacitive loads.

DIO207x is offered in Green or RoHS package and ESD (HBM) excesses 4kV. It is specified over the extended -40 to +125°C.

### Typical Application

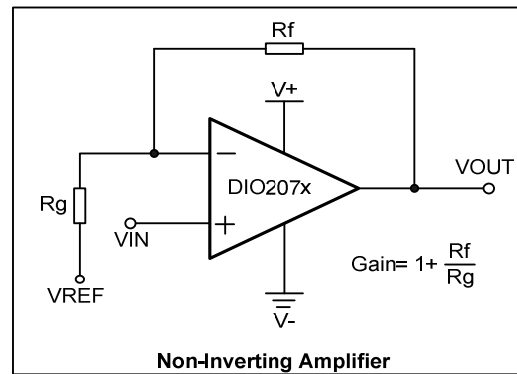

## Physical Dimensions: SOT-23-5

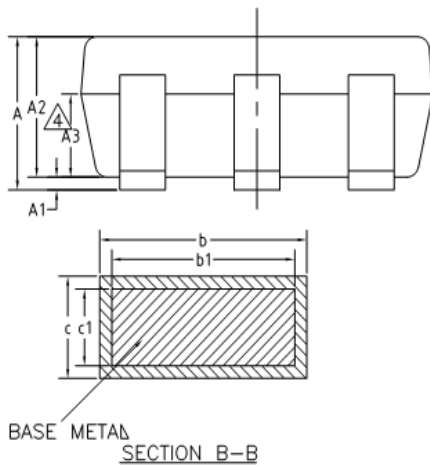
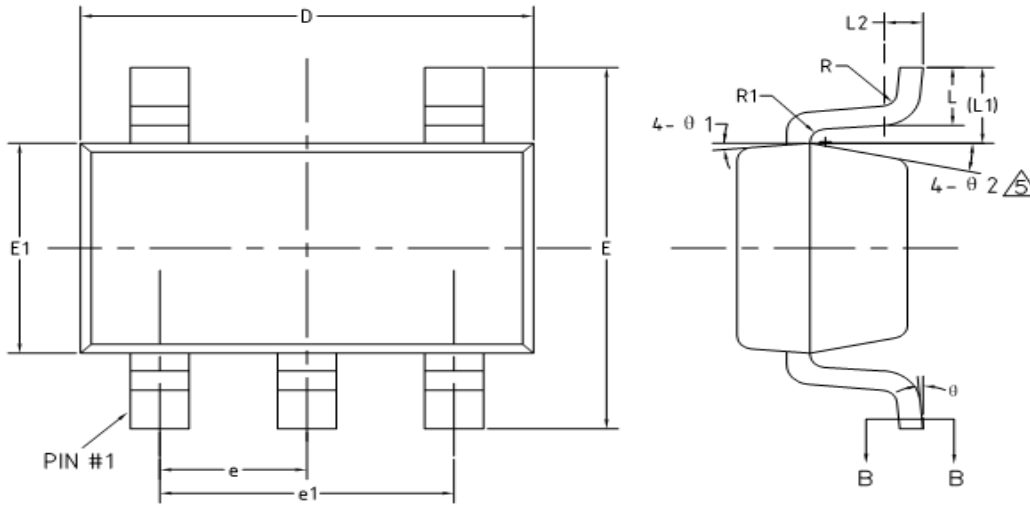

COMMON DIMENSIONS (UNITS OF MEASURE=MILLIMETER)			
Symbol	MIN	NOM	MAX
A	-	-	1.25
A1	0	-	0.15
A2	1.00	1.10	1.20
A3	0.60	0.65	0.70
b	0.36	-	0.50
b1	0.36	0.38	0.45
c	0.14	-	0.20
c1	0.14	0.15	0.16
D	2.826	2.926	3.026
E	2.60	2.80	3.00
E1	1.526	1.626	1.726
e	0.90	0.95	1.00
e1	1.80	1.90	2.00
L	0.35	0.45	0.60
L1	0.59REF		
L2	0.25BSC		
R	0.10	-	-
R1	0.10	-	0.25
θ	0°	-	8°
θ1	3°	5°	7°
θ2	6°	-	14°

## Physical Dimensions: SOIC-8

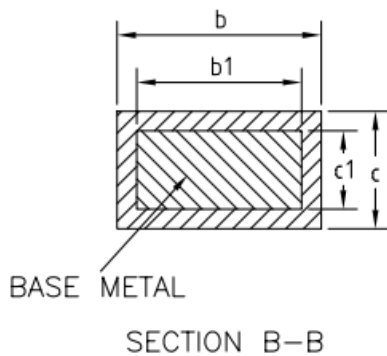
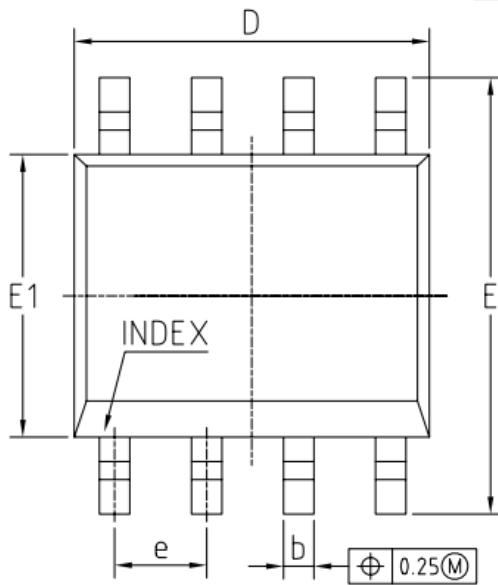
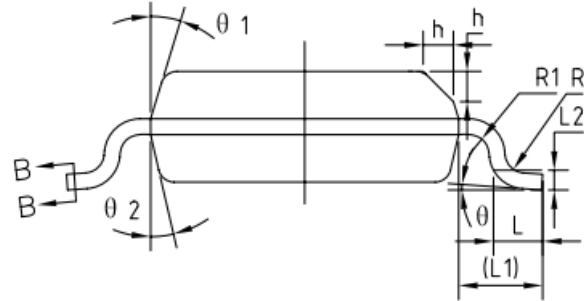
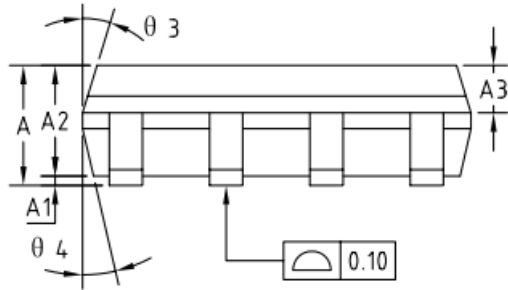

COMMON DIMENSIONS (UNITS OF MEASURE=MILLIMETER)			
Symbol	MIN	NOM	MAX
A	1.35	1.55	1.75
A1	0.10	0.15	0.25
A2	1.25	1.40	1.65
A3	0.50	0.60	0.70
b	0.38	-	0.51
b1	0.37	0.42	0.47
c	0.17	-	0.25
c1	0.17	0.20	0.23
D	4.80	4.90	5.00
E	5.80	6.00	6.20
E1	3.80	3.90	4.00
e	1.27BSC		
L	0.45	0.60	0.80
L1	1.04REF		
L2	0.25BSC		
R	0.07	-	-
R1	0.07	-	-
h	0.30	0.40	0.50
θ	0°	-	8°
θ1	15°	17°	19°
θ2	11°	13°	15°
θ3	15°	17°	19°
θ4	11°	13°	15°



# DIO207x

Single/Dual/Quad/Six channel RRIO 10MHz Amplifier

## Physical Dimensions: MSOP-8

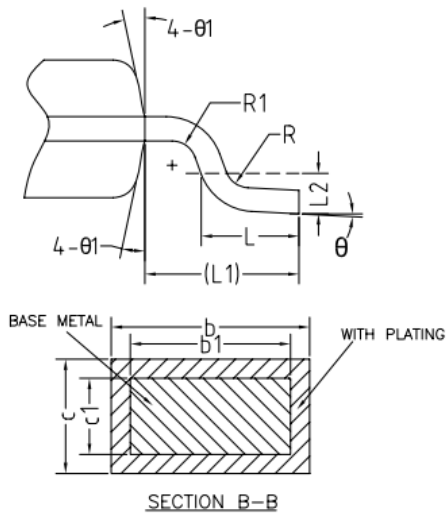
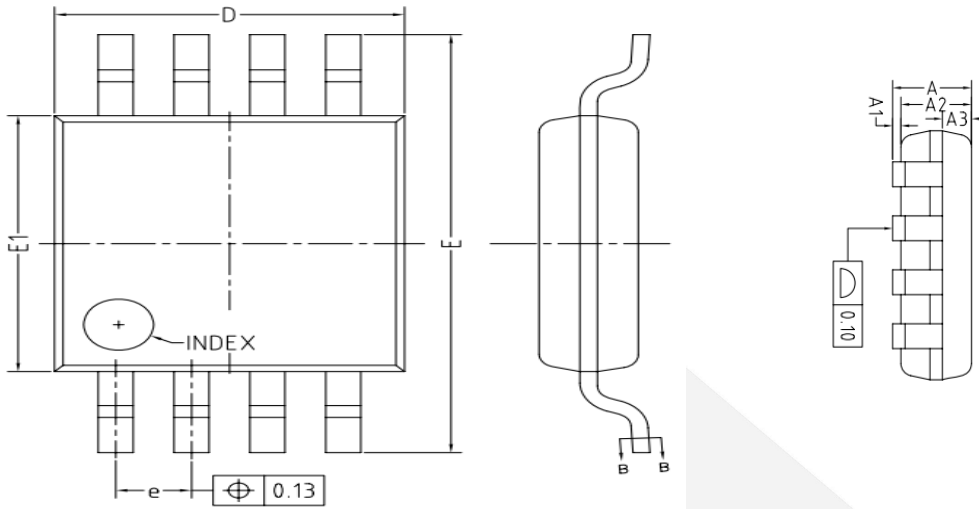

COMMON DIMENSIONS (UNITS OF MEASURE=MILLIMETER)			
Symbol	MIN	NOM	MAX
A	-	-	1.10
A1	0	-	0.15
A2	0.75	0.85	0.95
A3	0.25	0.35	0.39
b	0.28	-	0.37
b1	0.27	0.30	0.33
c	0.15	-	0.20
c1	0.14	0.15	0.16
D	2.90	3.00	3.10
E	4.70	4.90	5.10
E1	2.90	3.00	3.10
e	0.55	0.65	0.75
L	0.45	0.60	0.80
L1	0.95REF		
L2	0.25BSC		
R	0.07	-	-
R1	0.07	-	-
Ø	0°	-	8°
Ø1	9°	12°	15°

## Physical Dimensions: TSSOP-8

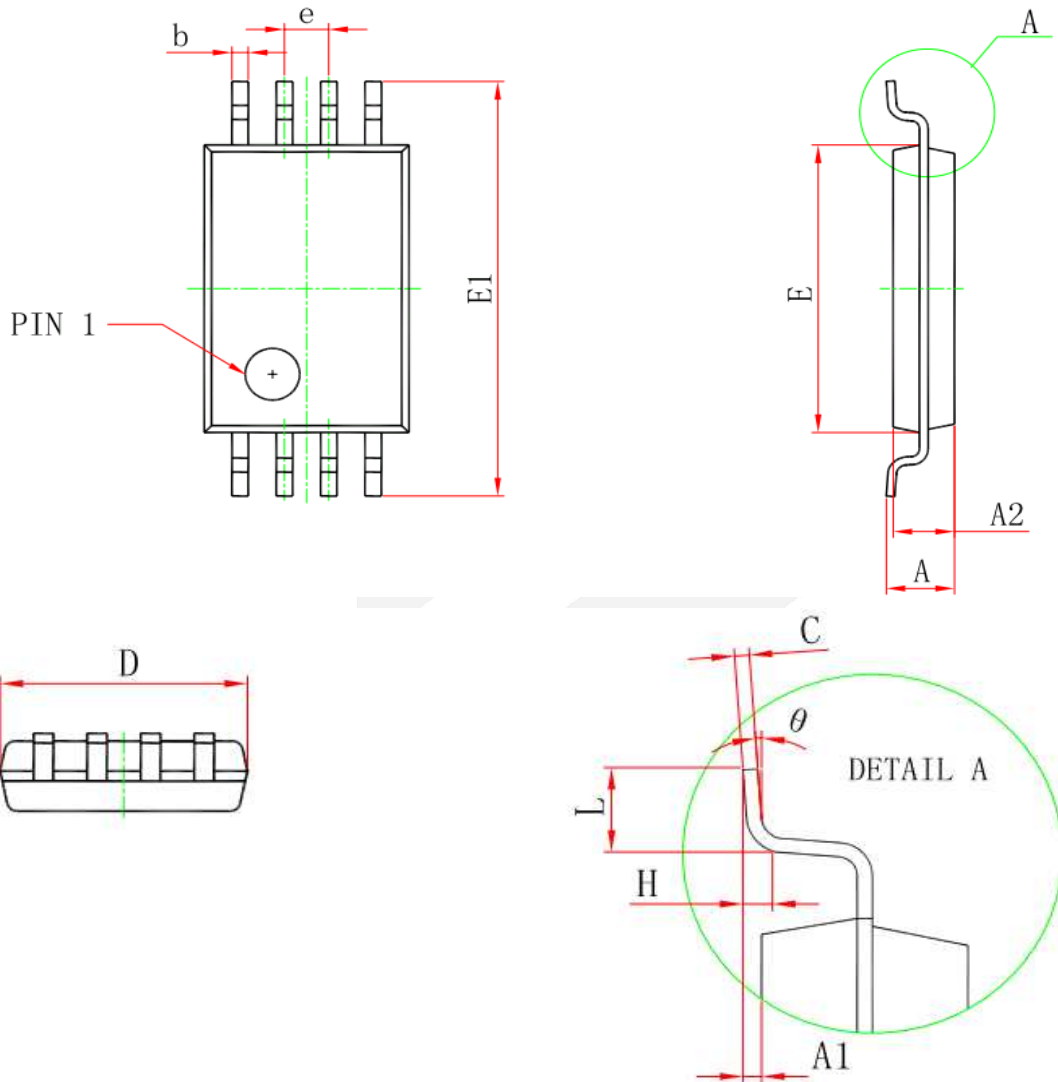

Symbol	Dimensions In Millimeters		Dimensions In Inches	
	Min	Max	Min	Max
D	2.900	3.100	0.114	0.122
E	4.300	4.500	0.169	0.177
b	0.190	0.300	0.007	0.012
c	0.090	0.200	0.004	0.008
E1	6.250	6.550	0.246	0.258
A		1.200		0.047
A2	0.800	1.000	0.031	0.039
A1	0.050	0.150	0.002	0.006
e	0.65 (BSC)		0.026 (BSC)	
L	0.500	0.700	0.020	0.028
H	0.25 (TYP)		0.01 (TYP)	
$\theta$	1°	7°	1°	7°

Physical Dimensions: SOIC-14

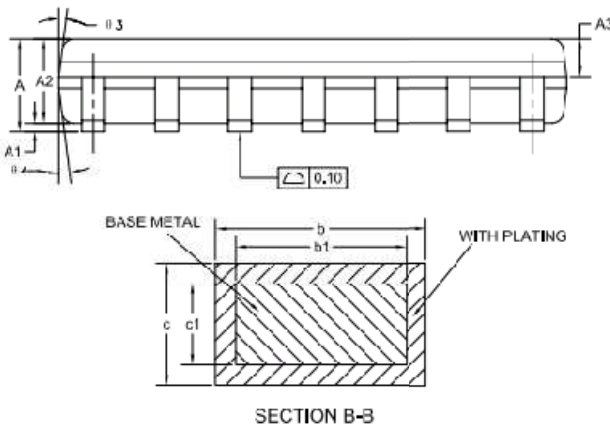
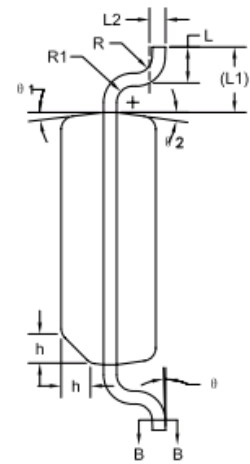
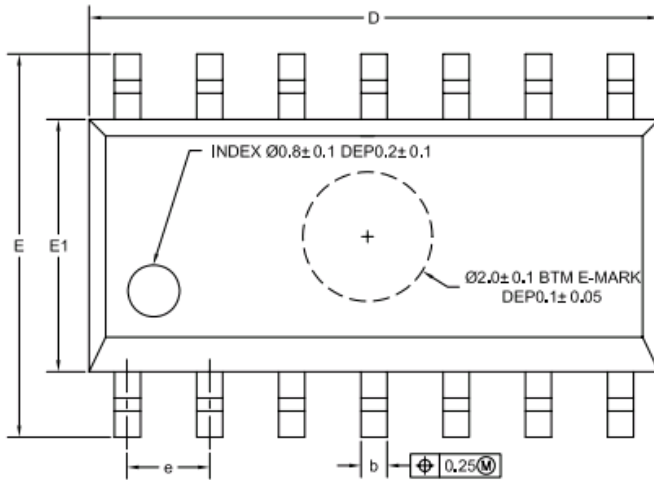

COMMON DIMENSIONS (UNITS OF MEASURE=MILLIMETER)			
Symbol	MIN	NOM	MAX
A	1.35	1.60	1.75
A1	0.10	0.15	0.25
A2	1.25	1.45	1.65
A3	0.55	0.65	0.75
b	0.36	-	0.49
b1	0.35	0.40	0.45
c	0.17	-	0.25
c1	0.17	0.20	0.23
D	8.53	8.63	8.73
E	5.80	6.00	6.20
E1	3.80	3.90	4.00
e	1.27 (BSC)		
L	0.45	0.60	0.80
L1	1.04 (RFE)		
L2	0.25 (BSC)		
R	0.07	-	-
R1	0.07	-	-
h	0.30	0.40	0.50
Θ	0°	-	8°
Θ1	6°	8°	10°
Θ2	6°	8°	10°
Θ3	5°	7°	9°
Θ4	5°	7°	9°

## Physical Dimensions: QFN-16

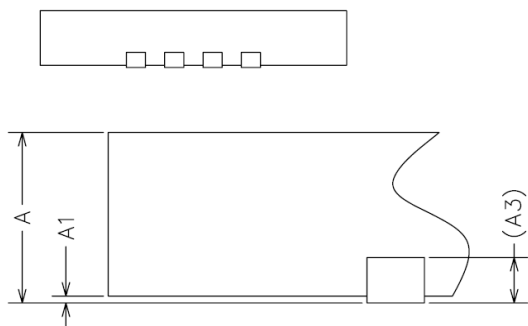
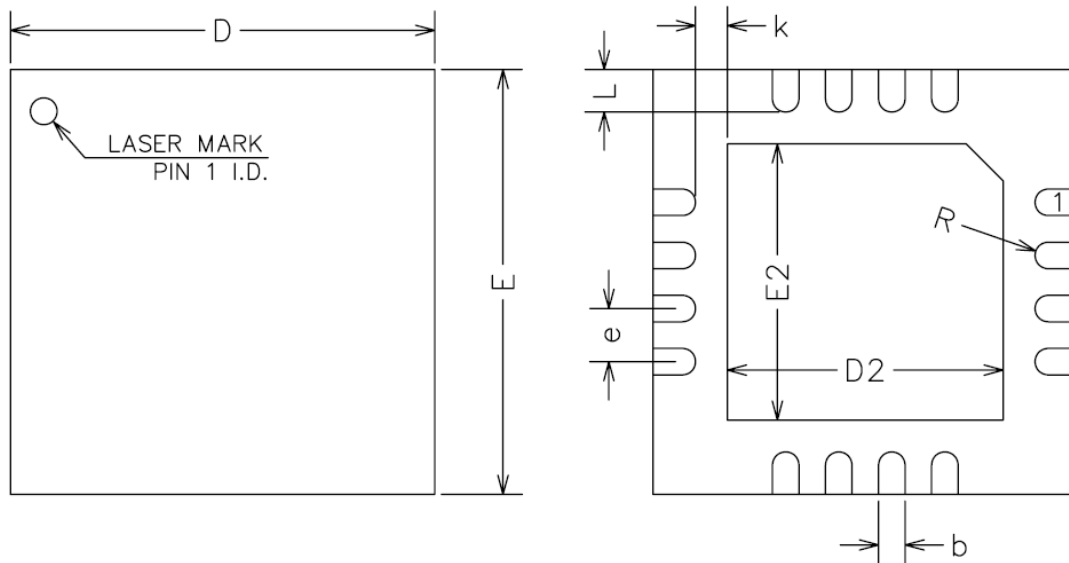

COMMON DIMENSIONS (UNITS OF MEASURE=MILLIMETER)			
Symbol	MIN	NOM	MAX
A	0.70	0.75	0.80
A1	0	0.02	0.05
A3	0.20REF		
b	0.20	0.25	0.30
D	3.90	4.00	4.10
E	3.90	4.00	4.10
D2	2.50	2.60	2.70
E2	2.50	2.60	2.70
e	0.40	0.50	0.60
K	0.20	-	-
L	0.35	0.40	0.45
R	0.09	-	-

## Physical Dimensions: SOIC-20

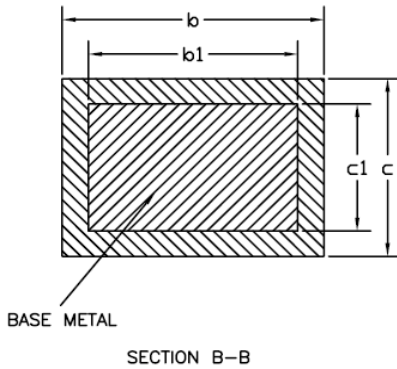
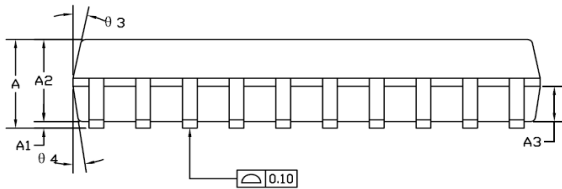
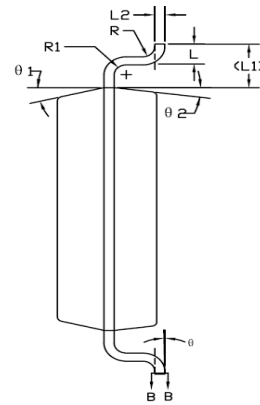
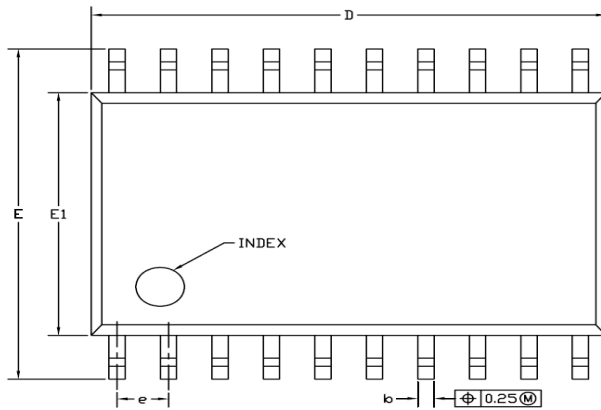

COMMON DIMENSIONS (UNITS OF MEASURE=MILLIMETER)			
Symbol	MIN	NOM	MAX
A	2.35	2.52	2.65
A1	0.10	0.20	0.30
A2	2.05	2.35	2.55
A3	0.90	1.00	1.10
b	0.35	-	0.49
b1	0.35	0.40	0.45
c	0.23	-	0.32
c1	0.20	0.25	0.30
D	12.60	12.70	12.80
E	10.00	10.20	10.60
E1	7.40	7.50	7.60
e	1.27BSC		
L	0.50	0.80	1.27
L1	1.35REF		
L2	0.25BSC		
R	0.07	-	-
R1	0.07	-	-
θ	0°	-	8°
θ1	10°	12°	14°
θ2	6°	8°	10°
θ3	9°	11.5°	14°
θ4	6°	8°	10°





# DIO207x

Single/Dual/Quad/Six channel RRIO 10MHz Amplifier

## Physical Dimensions: QFN-28

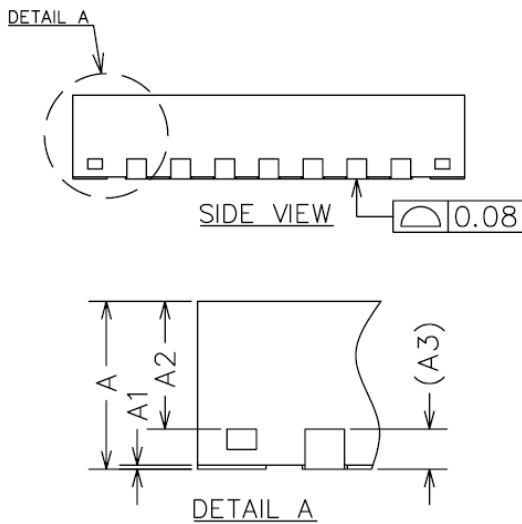
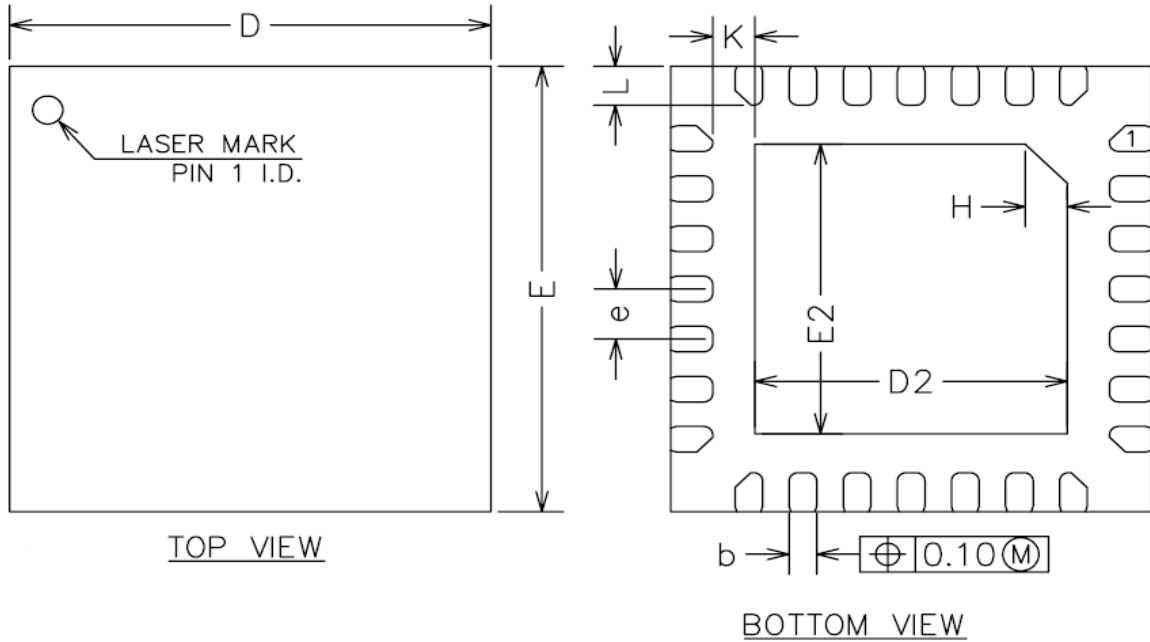

COMMON DIMENSIONS (UNITS OF MEASURE=MILLIMETER)			
Symbol	MIN	NOM	MAX
A	0.80	0.85	0.90
A1	0.00	0.02	0.05
A2	0.60	0.65	0.70
A3	0.20REF		
b	0.18	0.23	0.28
D	3.90	4.00	4.10
E	3.90	4.00	4.10
D2	2.50	2.60	2.70
E2	2.50	2.60	2.70
e	0.35	0.45	0.55
H	0.35REF		
K	0.25	-	-
L	0.30	0.35	0.40