

DIO8650C

Single Stage Flyback & PFC Controller With Primary Side Control For LED Lighting

Features

- Primary side control eliminates the opto-coupler
- Valley turn-on of the primary MOSFET to achieve lower switching losses
- Power factor >0.95 @230VAC
- THD $< 10\%$ @230VAC
- Reliable short LED and Open LED protection
- Quick start up: $<500\text{ms}$
- Low start up current: $15\mu\text{A}$ typical
- Package: SOT23-6, SOIC-8

Descriptions

The DIO8650C is a single stage Flyback and PFC controller targeting at LED lighting applications.

The DIO8650C is a primary side controller without applying any secondary feedback circuit for low cost, and drives the Flyback converter in the quasi-resonant mode to achieve higher efficiency.

The DIO8650C keeps the Flyback converter in constant on time operation to achieve high power factor.

This chip adopts special design to achieve quick start up and reliable protection for safety requirement.

Applications

- LED Lighting

Block Diagram

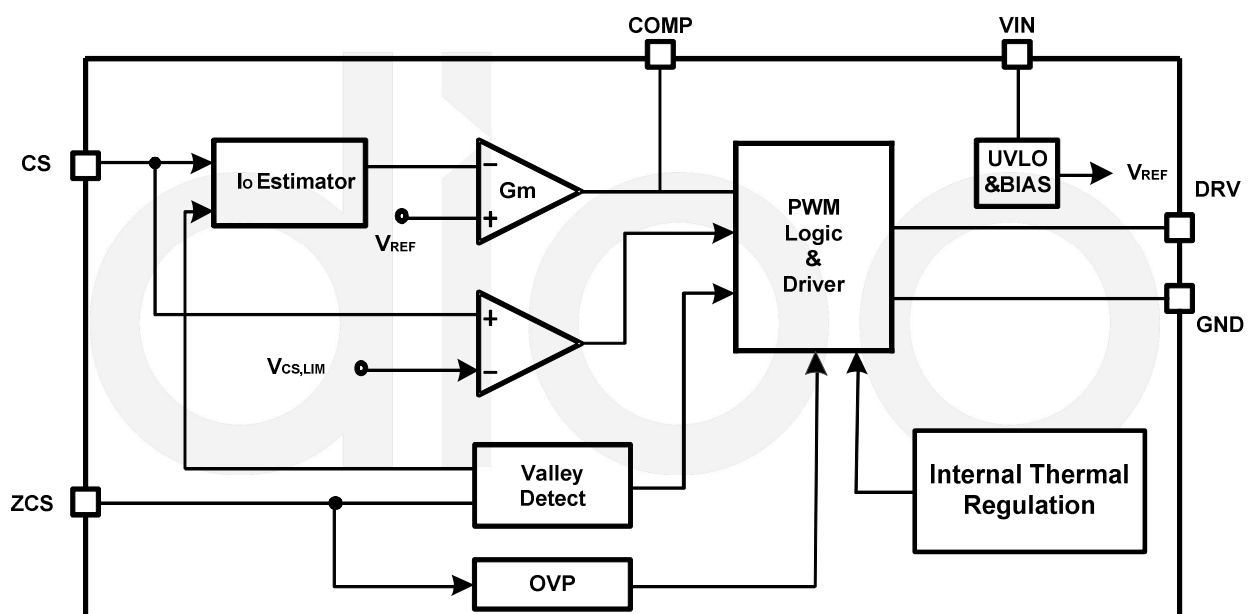

Figure1 Block Diagram

Ordering Information

Order Part Number	Top Marking		T _A	Package	
DIO8650CCST6	YW6C	Green	-40 to +85°C	SOT23-6	Tape & Reel, 3000
DIO8650CCS8	DIO8650C	Green	-40 to +85°C	SOIC-8	Tape & Reel, 2500

Pin Assignments

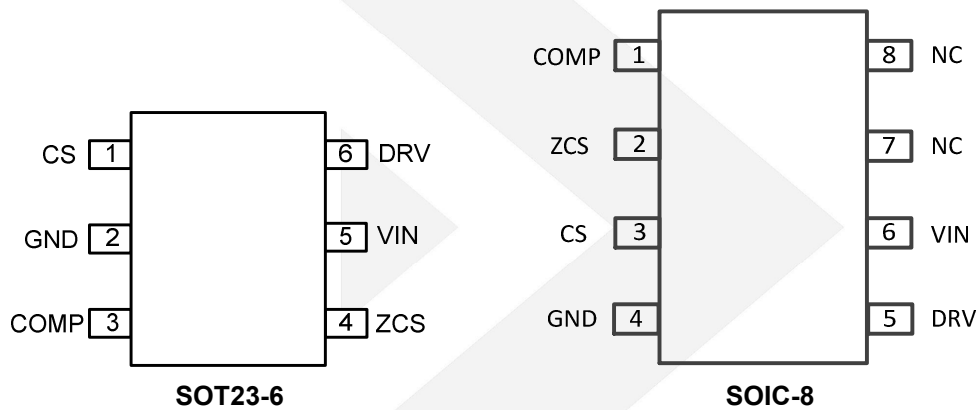

Figure 2 Pin Assignment (Top View)

Pin Definitions

Pin Name	Description
CS	Current sense pin. Connect this pin to the source of the primary switch. Connect the sense resistor across the source of the primary switch and the GND pin. (current sense resistor Resistor: $R_{CS} = k \times \frac{V_{ref} \times N_{ps}}{I_{out}}$, $k=0.167$) Also this pin used to detect transformer and secondary is short or not.
GND	Ground pin
COMP	Loop compensation pin. Connect a RC network across this pin and ground to stabilize the control loop.
ZCS	Inductor current zero-crossing detection pin. This pin receives the auxiliary winding voltage by a resistor divider and detects the inductor current zero crossing point. This pin also provides over voltage protection and line regulation modification function simultaneously. If the voltage on this pin is above $V_{ZCS,OV}$, the IC would enter over voltage protection mode. Good line regulation can be achieved by adjusting the upper resistor of the divider
VIN	Power supply pin. This pin also provides output over voltage protection along with ZCS pin.
DRV	Gate driver pin. Connect this pin to the gate of primary MOSFET.
NC	Not Connect.



DIO8650C

Single Stage Flyback & PFC Controller With Primary Side Control For LED Lighting

Absolute Maximum Ratings

Stresses beyond those listed under "Absolute Maximum Rating" may cause permanent damage to the device. These are stress ratings only and functional operation of the device at these or any other condition beyond those indicated in the operational sections of the specifications is not implied. Exposure to absolute maximum rating conditions for extended periods may affect device reliability.

Parameter		Rating	Unit
VIN, DRV		-0.3 to 33	V
Supply Current I _{VIN}		15	mA
ZCS		-0.3 to VIN+0.3	V
CS, COMP		-0.3 to 5	V
Power Dissipation, P _D @ T _A = 25°C, SOT23-6		0.6	W
Package Thermal Resistance, SOT23-6	θ _{JA}	170	°C/W
	θ _{JC}	130	
Power Dissipation, P _D @ T _A = 25°C, SOIC-8		1.1	W
Package Thermal Resistance, SOIC-8	θ _{JA}	100	°C/W
	θ _{JC}	50	
Storage Temperature Range		-65 to 150	°C
Junction Temperature Range		150	°C
Lead Temperature Range		260	°C
ESD	HBM, JEDEC: JESD22-A114	2000	V
	MM, JEDEC: JESD22-A115	200	

Recommend Operating Conditions

The Recommended Operating Conditions table defines the conditions for actual device operation. Recommended Operating conditions are specified to ensure optimal performance to the datasheet specifications. DIOO does not Recommend exceeding them or designing to Absolute Maximum Ratings.

Parameter	Rating	Unit
Supply Voltage	9.5 to 27	V
Junction Temperature Range	-40 to 125	°C
Ambient Temperature Range	-40 to 85	°C



DIO8650C

Single Stage Flyback & PFC Controller With Primary Side Control For LED Lighting

Electrical Characteristics

$V_{IN} = 12V$, $T_A = 25^\circ C$, unless otherwise specified.

Symbol	Parameter	Test Conditions	Min	Typ	Max	Unit
$V_{VIN,ON}$	VIN turn-on threshold			25.3		V
$V_{VIN,OFF}$	VIN turn-off threshold			8.5		V
$V_{VIN,OVP}$	VIN OVP voltage			30		V
I_{ST}	Start up Current	$V_{VIN} < V_{VIN,OFF}$		15		μA
$I_{VIN,OVP}$	Shunt current in OVP mode	After $V_{VIN} > V_{VIN,OVP}$, then set $V_{IN}=15V$	1.6	2	2.5	mA
I_Q	Quiescent Current	No switching		0.26		mA
I_{VIN}	Operation current	$C_L=100pF, f=15kHz$		0.36		mA
Error Amplifier Section						
V_{REF}	Internal reference voltage		0.294	0.3	0.306	V
ZCS pin Section						
V_{ZCS_OVP}	ZCS pin OVP voltage threshold			1.5		V
V_{FAST_ST}	Fast start up threshold			0.55		V
Current Sense Section(Source PIN of integrated MOSFET)						
V_{CS_LMT}	Current limit reference voltage			0.45		V
V_{CS_TR}	Protection limit for TR short			0.9		V
K_2	CC Feed forward coefficient			0.1		
R_{K2}	CC Feed forward resistor R_{K2}			340		Ω
PWM Section						
$T_{ON,MAX}$	Max on time	COMP high clamp		15.7		μs
T_{LEB}	Leading edge blanking time			300		ns
$T_{OFF,MAX}$	Max OFF time			151		μs
$T_{LEB,ZCD}$	ZCD Blanking Time	After turn off		2		μs
f_{MAX}	Maximum switching frequency			115		kHz
Gate Driver						
V_{GATE_CLAMP}	Output Clamp Voltage	$V_{CC}=20V$		12		V
T_{RISING}	rising time from 10% to 90%	$C_{LOAD}=1nF$		410		ns
$T_{FALLING}$	falling time from 90% to 10%	$C_{LOAD}=1nF$		50		ns
Thermal Section						
T_{SD}	Thermal Shutdown Temperature			150		$^\circ C$

Typical Application

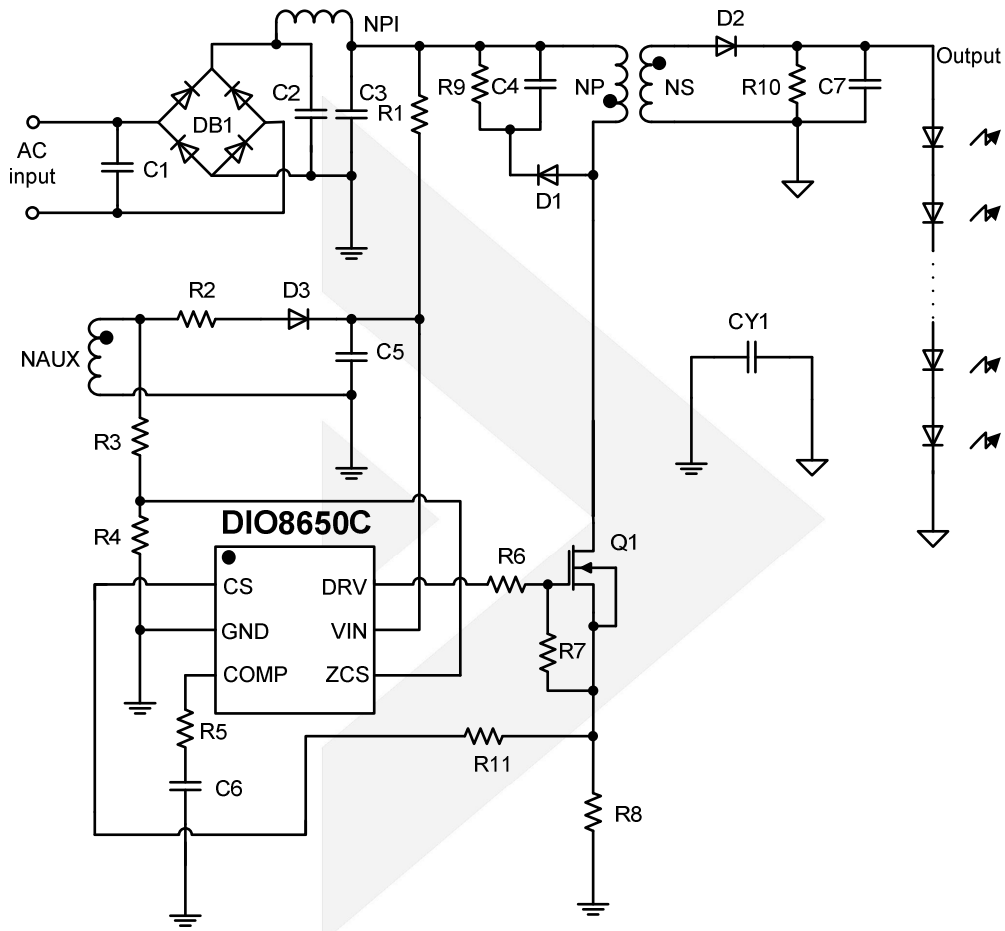

Figure 3 Typical flyback application



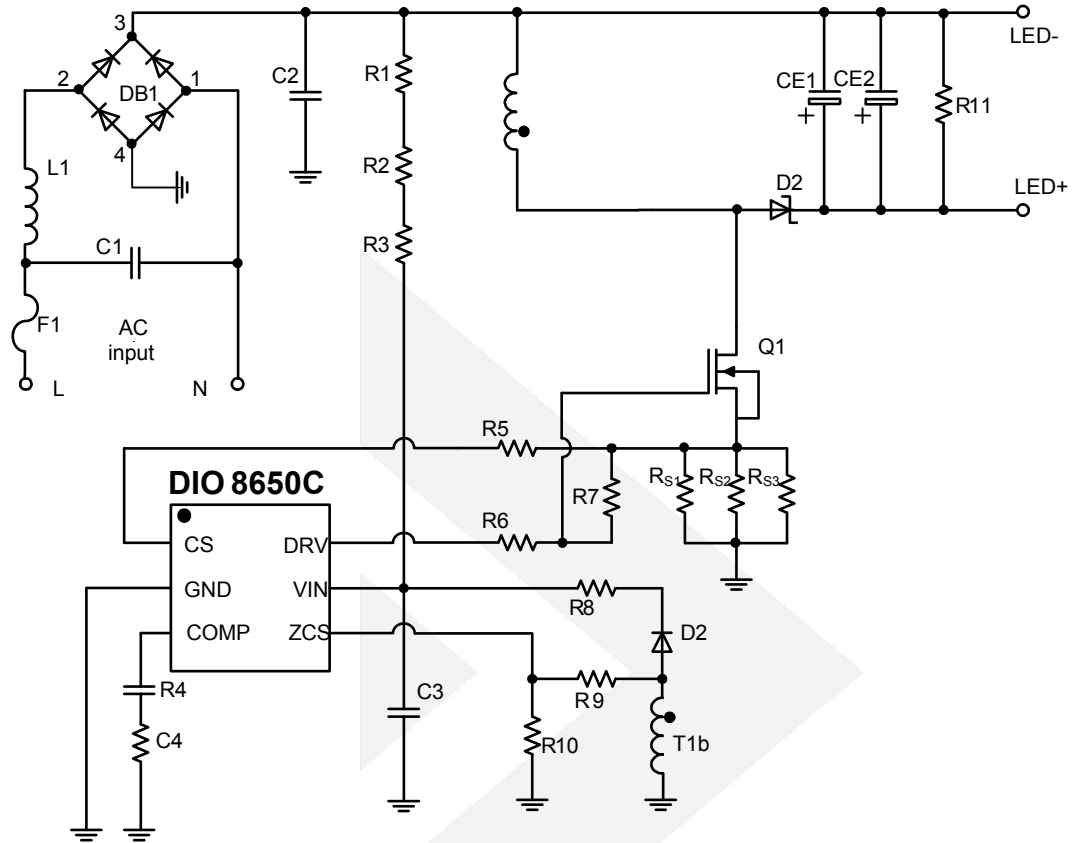

Figure 4 Typical buck-boost application

Application Information

Start up

After AC or DC supply is powered on, the capacitor C_{VIN} across VIN and GND pin is charged up by BUS voltage through a start up resistor R_{ST} . Once V_{VIN} rises up to V_{VIN-ON} , the internal blocks start to work and PWM output is enabled.

Shut down

After AC supply or DC BUS is powered off, the energy stored in the BUS capacitor will be discharged. When the auxiliary winding of Flyback transformer can't supply enough energy to VIN pin, V_{VIN} will drop down. Once V_{VIN} is below $V_{VIN-OFF}$, the IC will stop working and V_{COMP} will be discharged to zero.

Primary-side constant-current control

Primary side control is applied to eliminate secondary feedback circuit or opto-coupler, which reduces the circuit cost.



DIO8650C

Quasi-Resonant Operation

QR mode operation provides low turn-on switching losses for Flyback converter.

Over Voltage Protection (OVP) & Open LED Protection (OLP)

The output voltage is reflected by the auxiliary winding voltage of the Flyback transformer, and both ZCS pin and VIN pin provide over voltage protection function. When the load is null or large transient happens, the output voltage will exceed the rated value. When V_{VIN} exceeds $V_{VIN,OVP}$ or V_{ZCS} exceeds $V_{ZCS,OVP}$, the over voltage protection is triggered and the IC will discharge V_{VIN} by an internal current source $I_{VIN,OVP}$. Once V_{VIN} is below $V_{VIN,OFF}$, the IC will shut down and be charged again by BUS voltage through start up resistor. If the overvoltage condition still exists, the system will operate in hiccup mode.

Short Circuit Protection (SCP)

When the output is shorted to ground, the output voltage is clamped to zero. The voltage of the auxiliary winding is proportional to the output winding, so valley signal cannot be detected by ZCS. Without valley detection, MOSFET cannot be turned ON until maximum off time $t_{OFF,MAX}$ is matched. If MOSFET is turned ON by $t_{OFF,MAX}$ 64 times continuously, IC will be shut down and enter into hiccup mode. If the output voltage is not low enough to disable valley detection in short condition, V_{VIN} will dropdown without auxiliary winding supply. Once V_{VIN} is below $V_{VIN,OFF}$, the IC will shut down and be charged again by the BUS voltage through the start up resistor. If the short circuit condition still exists, the system will operate in hiccup mode.

