



Intel® Stratix® 10 DX FPGA Development Kit User Guide



Online Version



Send Feedback

UG-20255

ID: **683561**

Version: **2020.11.16**

Contents

1. Getting Started.....	4
1.1. About this Document.....	4
1.2. Installing the Intel Quartus® Prime Pro Edition Software.....	4
1.2.1. Activating Your License.....	4
1.3. Downloading the Board Package.....	4
1.4. Installing the Driver for Intel FPGA Download Cable II.....	5
2. Development Kit Overview.....	6
2.1. Supported Features.....	7
2.2. Recommended Operating Conditions.....	7
2.3. Handling the Board.....	8
3. Power Up the Development Kit.....	9
3.1. Default Switch Settings.....	9
3.2. Connectors and LEDs.....	12
3.3. Performing Board Restore through Board Test System (BTS)	13
3.4. Controlling On-board Clock.....	14
4. Board Test System (BTS).....	15
4.1. Preparing the Development Kit.....	16
4.2. Running the Board Test System.....	16
4.3. Using the Board Test System.....	17
4.3.1. Configure Menu.....	17
4.3.2. Sys Info Tab.....	18
4.3.3. GPIO Tab.....	19
4.3.4. QSFP Tab.....	20
4.3.5. Component DDR4 CH0 Tab.....	23
4.3.6. Component DDR4 CH1 Tab.....	24
4.3.7. DDR4 DIMM CH0 Tab.....	26
4.3.8. DDR4 DIMM CH1 Tab.....	27
4.3.9. Power Monitor.....	29
4.3.10. Clock Controller.....	30
4.4. Smart VID Setting.....	32
5. Development Kit Hardware and Configuration.....	34
5.1. FPGA Configuration.....	34
5.2. Programming the FPGA Over Intel FPGA Download Cable.....	34
5.3. Configuration Modes.....	35
5.3.1. Avalon Streaming Interface x8 Mode.....	35
5.3.2. JTAG Mode.....	40
6. Document Revision History for Intel Stratix 10 DX FPGA Development Kit User Guide..	42
A. Development Kit Components.....	43
A.1. Components Overview.....	44
A.2. Power, Thermal, and Mechanical Considerations.....	47
A.2.1. Power Guidelines.....	47
A.2.2. Thermal Requirements.....	53
A.2.3. Mechanical Requirements.....	54

A.3. Clock Circuits.....	56
A.4. Memory Interface.....	58
A.5. PCIe Interface.....	59
A.6. UPI Interface.....	59
A.7. Transceiver Signals: PCIe and UPI Interface.....	60
A.8. SlimSAS Connector.....	63
A.9. QSFP Network Interface.....	64
A.9.1. Dual Port Controller	65
A.10. I ² C Interface.....	66
A.11. QSPI Flash Memory.....	67
A.11.1. Configuration QSPI Flash Memory.....	67
A.11.2. NIOS QSPI Flash Memory.....	67
B. Safety and Regulatory Information.....	69
B.1. Safety Warnings.....	69
B.2. Safety Cautions.....	71
C. Compliance and Conformity Information.....	73

1. Getting Started

1.1. About this Document

This document provides comprehensive guidelines for designing with Intel® Stratix® 10 DX FPGA Development Kit. It covers information about the software installation, board components, and configuration.

Table 1. Ordering Information

Product	Ordering Code	Device Part Number
Intel Stratix 10 DX FPGA Development Kit (Production version)	DK-DEV-1SDX-P-A	1SD280PT2F55E1VG

1.2. Installing the Intel Quartus® Prime Pro Edition Software

The Intel Quartus® Prime Pro Edition software includes everything you need to design for Intel Stratix 10 FPGA from design entry and synthesis to optimization, verification, and simulation. For more information about downloading the Intel Quartus Prime Pro Edition software, refer to the [Download Center for Intel FPGAs](#).

1.2.1. Activating Your License

Before using the Intel Quartus Prime Pro Edition software, you must activate your license. If you already have a licensed version installed, you can use that license file with this development kit. Otherwise, follow these steps:

1. Log into your [My Intel](#) account.
2. Click on the **Intel FPGA Self Service Licensing Center**.
3. Locate the serial number printed on the side of the development kit box below the bottom bar code. The number consists of alphanumeric characters and does not contain hyphens.
4. On the **Intel FPGA Self Service Licensing Center** page, click the **Find it with your License Activation Code** link.
5. In the **Find/Activate Products** dialog box, enter your development kit serial number and click **Search**.

1.3. Downloading the Board Package

Download the appropriate board package for your Intel Stratix 10 DX FPGA Development Kit from the [Intel FPGA Development Kits](#) webpage. Unzip the package.

Figure 1. Directory Structure

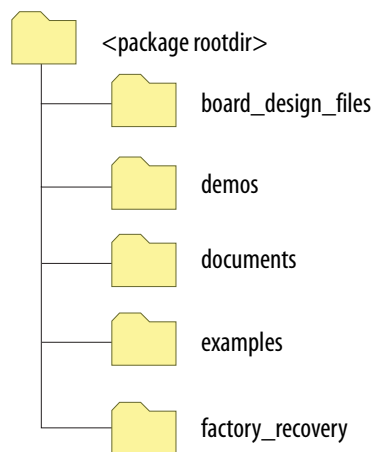

Table 2. Directory Description

Directory	Content Description
board_design_files	Contains schematic, layout, assembly, and bill of material board design files. Use these files as a starting point for a new prototype board design.
demos	Contains demonstration applications when available.
documents	Contains documentation.
examples	Contains sample design files for this development kit.
factory_recovery	Contains the original data programmed onto the board before shipment. Use this data to restore the board to its original factory settings.

1.4. Installing the Driver for Intel FPGA Download Cable II

The development board includes integrated Intel FPGA Download Cable circuits for FPGA programming. However, for the host computer and board to communicate, you must install the Intel FPGA Download Cable II driver on the host computer.

Installation instructions for the Intel FPGA Download Cable II driver for your operating system are available on the [Cable and Adapter Drivers Information](#) webpage.

2. Development Kit Overview

The Intel Stratix 10 DX FPGA Development Kit allows you to evaluate the performance, features, and operation of the Intel Stratix 10 DX device in the F2912 BGA package. It features P-tile transceivers with PCIe Gen4 x16 and Intel Ultra Path Interconnect (UPI) interfaces and E-tile transceivers with 25Gx4 or 56Gx2 quad small form-factor pluggable (QSFP) interfaces. It also supports 4xDDR4 x72 channels with two channels supporting the Intel Optane® DC Persistent memory module.

The UPI functionality is enabled by a combination of the appropriate P-Tile settings and UPI protocol IP core. The FPGA interface to Intel Optane DC Persistent memory module requires an Intel memory controller IP core. Both IP cores are available in Intel Quartus Prime Pro Edition software (additional licensing and enablement may apply).

Figure 2. Intel Stratix 10 DX FPGA Development Kit Block Diagram

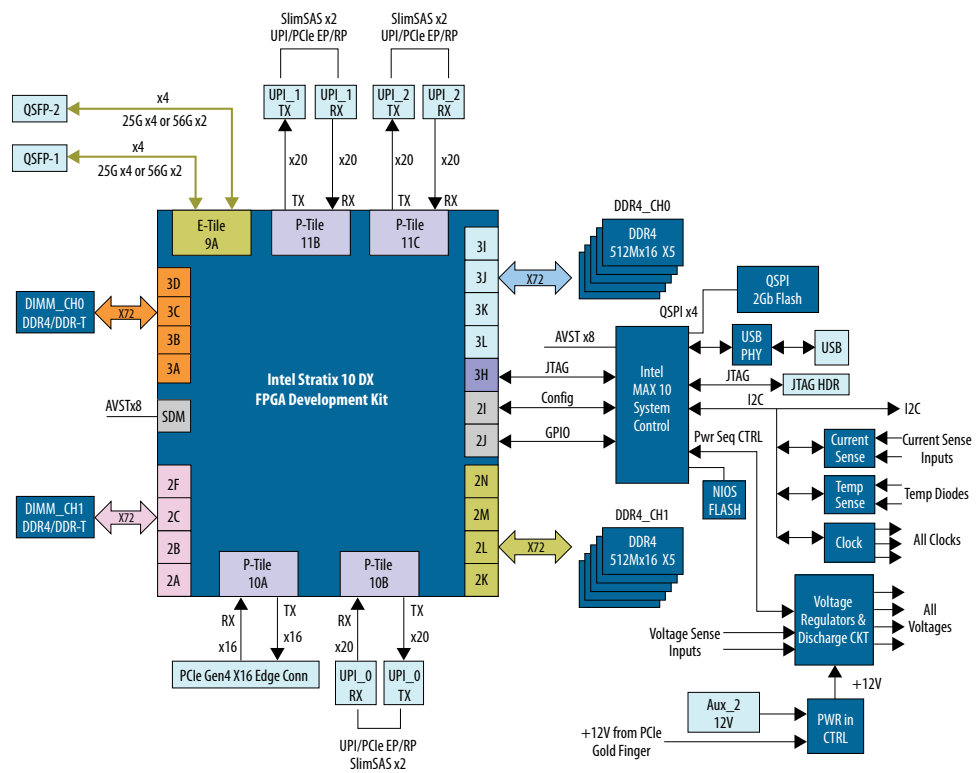

Intel Corporation. All rights reserved. Intel, the Intel logo, and other Intel marks are trademarks of Intel Corporation or its subsidiaries. Intel warrants performance of its FPGA and semiconductor products to current specifications in accordance with Intel's standard warranty, but reserves the right to make changes to any products and services at any time without notice. Intel assumes no responsibility or liability arising out of the application or use of any information, product, or service described herein except as expressly agreed to in writing by Intel. Intel customers are advised to obtain the latest version of device specifications before relying on any published information and before placing orders for products or services.

*Other names and brands may be claimed as the property of others.

2.1. Supported Features

Table 3. Supported Features

Category	Features
Intel Stratix 10 DX FPGA	<ul style="list-style-type: none"> 0.85-0.89V/VID-adjustable VCC core, 2912 pin BGA package P-Tile transceivers supporting PCIe Gen4 or UPI E-Tile transceivers supporting 28Gbps NRZ and 56Gbps PAM4
FPGA configuration	<ul style="list-style-type: none"> Partial reconfiguration support CVP configuration support 2Gb QSPI Flash Storage for one configuration image in flash JTAG header for device programming Built-in Intel FPGA Download Cable for device programming
Programmable clock sources	<ul style="list-style-type: none"> 312.53125 Mhz and 156.25 MHz Differential LVDS for QSFP 100 Mhz Differential LVDS for PCIe 133 Mhz Differential LVDS for Memory 125 Mhz Configuration clock 100 Mhz Differential LVDS for IO banks
Transceiver interfaces	<ul style="list-style-type: none"> PCIe x16 interface supporting Gen4 End-Point mode connected to a x16 PCIe edge connector (gold edge fingers) 2x standard QSFP56 optical module interfaces connected to the E-tile transceivers 3x UPI or PCIe interface supporting UPI x20 at 11.2Gbps or PCIe x16 at 16Gbps via SlimSAS connectors (cables shipped separately)
Memory interfaces	<ul style="list-style-type: none"> Two on-board independent single rank DDR4 x72 (ECC) channels operating at 1200 MHz (DDR4-2400) Two DIMM sockets supporting DDR4 DIMM or Intel's Optane DC Persistent memory module
Communication ports	<ul style="list-style-type: none"> 2xQSFP28 optical interface port JTAG header USB (Micro USB) on-board Intel FPGA Download Cable II System I2C header
Buttons, Switches, and LEDs	<ul style="list-style-type: none"> System Reset Push button CPU Reset Push button PCIe Reset Push button Four dedicated User LEDs Link LED of each QSFP28 port to indicate the link and data transceiver Two dedicated configuration status LEDs
Heatsink and Fan	<ul style="list-style-type: none"> Air-cooled heatsink assembly Red Over-Temperature Warning LED Indicator
Power	<ul style="list-style-type: none"> PCIe input power including required 2x4 AUX power connector Blue Power-On LED On/Off Slide Power Switch for benchtop operation On board power and temperature measurement circuitry
Mechanical	<ul style="list-style-type: none"> PCIe standard height form factor 4.376" x 10.0" board size 2 Slots height with heatsink

2.2. Recommended Operating Conditions

Follow these operating range or limit for different physical parameters:

- Ambient operating temperature range: 0°C to 35°C
- Maximum ICC load current: 192 A
- Maximum ICC load transient percentage: 30%
- FPGA maximum power supported by the supplied heatsink/fan: 192 W

2.3. Handling the Board

When handling the board, it is important to observe static discharge precautions.

Caution: Without proper anti-static handling, the board can be damaged. Therefore, use anti-static handling precautions when touching the board.

Important: This development kit should not be operated in a vibrating environment.

3. Power Up the Development Kit

The Intel Stratix 10 DX FPGA development kit is designed to operate in two modes:

- As a PCIe* add-in card
- Bench-top mode

When operating the card as a PCIe system, insert the card into an available PCIe slot and connect a 2x4 pin PCIe power cable from the system to power connectors at **J42** of the board.

Note: When operating as a PCIe add-in card, the board does not power on unless power is supplied to **J42**.

In Bench-top mode, you must supply the board with 240 W of power supply connected to the power connector **J42**.

This development kit ships with its switches preconfigured to support the design examples in the kit. If you suspect that your board may not be correctly configured with the default settings, refer to the *Default Switch and Jumper Settings* section of this chapter.

Follow these instructions:

1. Connect the supplied power supply to an outlet and the DC Power Jack (J42) on the FPGA board.

Note: Use only the supplied power supply. Power regulation circuits on the board can be damaged by power supplies with greater voltage.

2. Set the power switch (**SW31**) to the ON position.

When the board powers up, the blue LED illuminates and the board is ready for use. The Orange LED (**D56**) should also illuminate indicating that all the power rails on the board are good. If the POWER GOOD LED (**D56**) is not illuminated, it indicates that the power supply is malfunctioned and the board will not power up.

Note: The standby powers are always present as soon as the AUX power is applied to **J42**. Use power switch **SW31** to start the board.

3.1. Default Switch Settings

This development kit ships with its switches preconfigured to support the design examples in the kit. If you suspect that your board may not be correctly configured with the default settings, refer to the following table to return to its factory settings before proceeding.

Table 4. Default Switch Settings

Switch	Default Position	Description				
SW1[1:4]	ON/OFF/OFF/X	Configuration mode setting bits:				
		Mode	MSEL0	MSEL1	MSEL2	QSPI_AVST_SEL
		JTAG	OFF (Open)	OFF (Open)	OFF (Open)	X
		Avalon-ST	ON (Close)	OFF (Open)	OFF (Open)	X
SW33[1:4]	OFF/X/ON/ON	JTAG, MAX10, UPI controls:				
		SW33	ON (Close)	OFF (Open)		
		1 - JTAG Debug	JTAG Header (J2) dedicated for Max10		Normal JTAG (Default)	
		2 - JTAG SOURCE	Not used		Not used	
		3 - UPI Mode	2 Sockets		4 Sockets	
		4 - M10 JTAG EN	M10 JTAG Enabled		M10 JTAG Disabled	
SW2[1:4]	ON/ON/ON/ON	PCIe PRSNT X1/x4/x8/x16 settings:				
		PCIe PRSNT X1	PCIe PRSNT X4	PCIe PRSNT X8	PCIe PRSNT X16	
		ON (Close)	ON (Close)	ON (Close)	ON (Close)	
SW28	ON (Close)	PCIe Edge connector PERSTn selection: <ul style="list-style-type: none"> ON: Endpoint (Default) OFF: Root Port 				
SW27	ON (Close)	Intel Stratix 10 DX PERSTn selection: <ul style="list-style-type: none"> ON: Endpoint (Default) OFF: Root Port 				
SW16	ON (Close)	UPI0 PERSTn selection - UPI0 connector side: <ul style="list-style-type: none"> ON: PERSTn from PCIe Edge connector to FPGA OFF: PERSTn from FPFA to CPU (Default) 				
SW24	ON (Close)	UPI0 PERSTn selection - FPGA side: <ul style="list-style-type: none"> ON: PERSTn from FPGA to CPU (Default) OFF: PERSTn from PCIe Edge connector to FPGA 				
SW17	ON (Close)	UPI1 PERSTn selection - UPI1 connector side: <ul style="list-style-type: none"> ON: PERSTn from PCIe Edge connector to FPGA OFF: PERSTn from FPFA to CPU (Default) 				
SW25	ON (Close)	UPI1 PERSTn selection - FPGA side: <ul style="list-style-type: none"> ON: PERSTn from FPGA to CPU (Default) OFF: PERSTn from PCIe Edge connector to FPGA 				
SW18	ON (Close)	UPI2 PERSTn selection - UPI2 connector side: <ul style="list-style-type: none"> ON: PERSTn from PCIe Edge connector to FPGA OFF: PERSTn from FPFA to CPU (Default) 				
SW26	ON (Close)	UPI2 PERSTn selection - FPGA side:				
<i>continued...</i>						

Switch	Default Position	Description
		<ul style="list-style-type: none"> ON: PERSTn from FPGA to CPU (Default) OFF: PERSTn from PCIe Edge connector to FPGA
SW14	ON (Close)	PCIe REFCLK source selection: <ul style="list-style-type: none"> ON: 100MHz REFCLK internal generated OFF: 100MHz REFCLK from PCIe Edge Connector (Default)
SW31	ON (Close) or OFF (Open)	Power switch: <ul style="list-style-type: none"> ON: Turn on power (set to this position for use in PCIe slot) OFF: Turn off power This switch must be ON when the card is plugged into a PCIe slot <i>Note:</i> (with 2x4 Aux power connected) or on the bench with external ATX power supply.

Figure 3. Location of Switches and Push Buttons

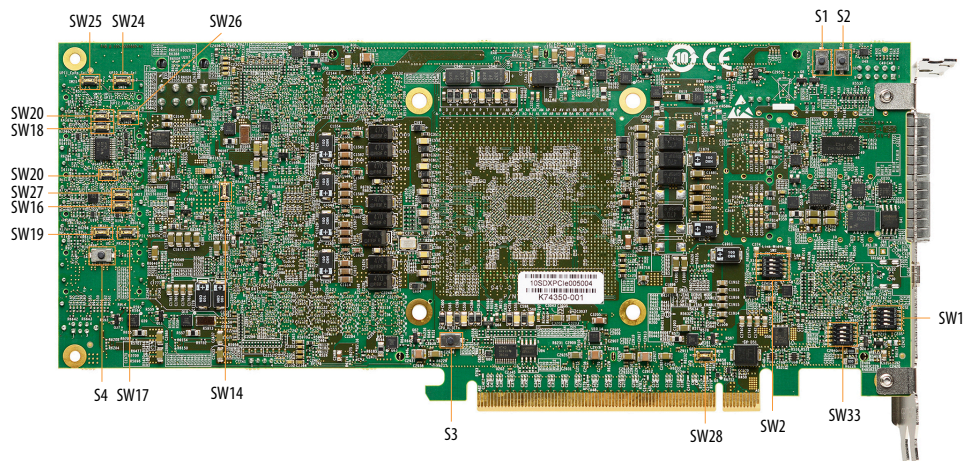

Table 5. Push Buttons

Push Buttons		Descriptions
S1	PCIe Reset	Push to reset PCIe bus
S2	MAX10 Reset	Push to reset Max10
S3	CPU Reset	Push to reset FPGA
S4	USER Push Button	Push button for user assigned function

3.2. Connectors and LEDs

Figure 4. Location of Connectors and LEDs

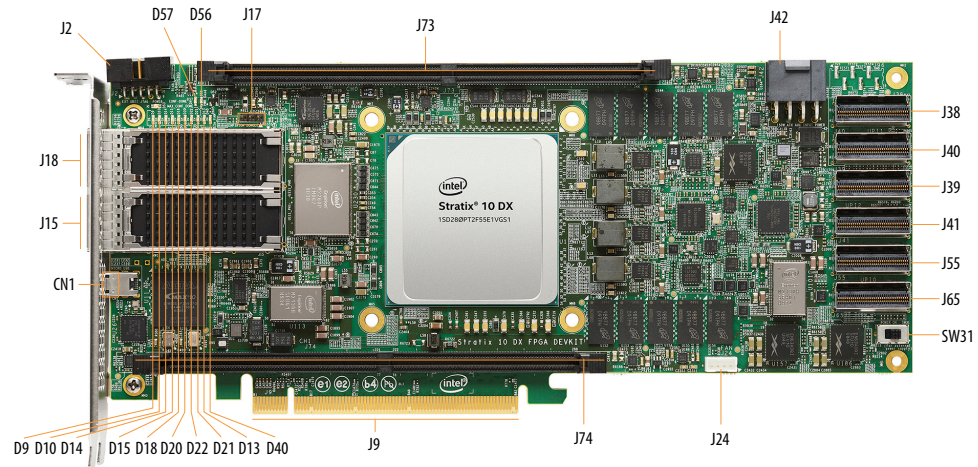

Table 6. Connectors

Connector		Description
J2	External JTAG connector	For use with Intel FPGA Download Cable
J42	AUX Power connector	For external 12V AUX power supply or power adapter
J97	I2C/PMBus connector	For accessing the core power controller
J17	I2C connector	To access I2C bus
J15	QSFP 1 connector	For using the QSFP interface
J18	QSFP 2 connector	
CN1	USB connector	For programming FPGA using on-board Intel FPGA Download Cable
J73	DIMM 0 connector	For DDR4/DDR-T memory channel 0
J74	DIMM 1 connector	For DDR4/DDR-T memory channel 1
J9	PCIe x16 Gold Finger	For using the PCIe interface
J38	UPI 1 Transmit	For UPI Link 1 connection from FPGA to CPU
J40	UPI 1 Receive	For UPI Link 1 connection from CPU to FPGA
J39	UPI 2 Transmit	For UPI Link 2 connection from FPGA to CPU
J41	UPI 2 Receive	For UPI Link 2 connection from CPU to FPGA
J55	UPI 0 Transmit	For UPI Link 0 connection from FPGA to CPU
J65	UPI 0 Receive	For UPI Link 0 connection from CPU to FPGA
J24	Fan connector	For connecting to the heatsink cooling fan

Table 7. LEDs

LEDs		Description
D18	QSFP 1 Link LED for 25G	Green LED: <ul style="list-style-type: none"> • ON: link • Blinks: Activities
D20	QSFP 1 Link LED for 10G	Yellow LED: <ul style="list-style-type: none"> • ON: link • Blinks: Activities
D22	QSFP 2 Link LED for 25G	Green LED: <ul style="list-style-type: none"> • ON: link • Blinks: Activities
D21	QSFP 2 Link LED for 10G	Yellow LED: <ul style="list-style-type: none"> • ON: link • Blinks: Activities
D9	USER LED 0	Green LED for USER LED 0
D10	USER LED 1	Green LED for USER LED 1
D14	USER LED 2	Green LED for USER LED 2
D15	USER LED 3	Green LED for USER LED 3
D56	POWER GOOD LED	Yellow LED: <ul style="list-style-type: none"> • ON: All power is good • OFF: Power failure
D57	CONFIG DONE LED	Green LED: <ul style="list-style-type: none"> • ON: FPGA configuration successful • OFF: FPGA configuration failed
D13	MAX10 CONFIG DONE LED	Green LED: <ul style="list-style-type: none"> • ON: MAX10 configuration successful • OFF: MAX10 configuration failed
D40	Over Temp LED	Red LED: <ul style="list-style-type: none"> • ON: • OFF:
D53	POWER LED	Blue LED: <ul style="list-style-type: none"> • ON: Devkit power is on • OFF: Devkit power is off

3.3. Performing Board Restore through Board Test System (BTS)

The development kit ships with FPGA design examples stored in the QSPI flash device and pre-programmed Intel MAX[®] 10 system. If you want to restore the board QSPI flash with the default factory image, follow these steps:

1. Connect USB cable between **CN1** USB connector and your computer.
2. Open Intel Quartus Prime Pro Edition Programmer.
3. Detect JTAG chain and attach factory default image on system Intel MAX 10 device.
4. Select programming options and click **Program** button.

3.4. Controlling On-board Clock

The clock controller application can change the on-board Si53XX programmable oscillators to any customized frequency between 0.2 MHz and 800 MHz.

The clock control application (`ClockControl.exe`) runs as a stand-alone application and resides in the location `<package_dir>\examples\board_test_system`. The clock control application communicates with the system Intel MAX 10 device through either USB port CN1 or 10pin JTAG header J2. The system Intel MAX 10 device controls these programmable clock parts through a two-wire serial bus.

4. Board Test System (BTS)

The Intel Stratix 10 DX FPGA Development Kit includes an application called Board Test System (BTS) to test the functionality of this board. The BTS provides an easy-to-use Graphical User Interface (GUI) to alter functional settings and observe results. You can use the BTS to test board components, modify functional parameters, observe performance, and measure power usage.

The BTS communicates over the JTAG bus to a test design running in the Intel Stratix 10 DX FPGA device. You can use the BTS to reconfigure the FPGA with test designs specific to the functionality that you are testing.

The BTS is also useful as a reference for designing systems.

Figure 5. BTS GUI Home

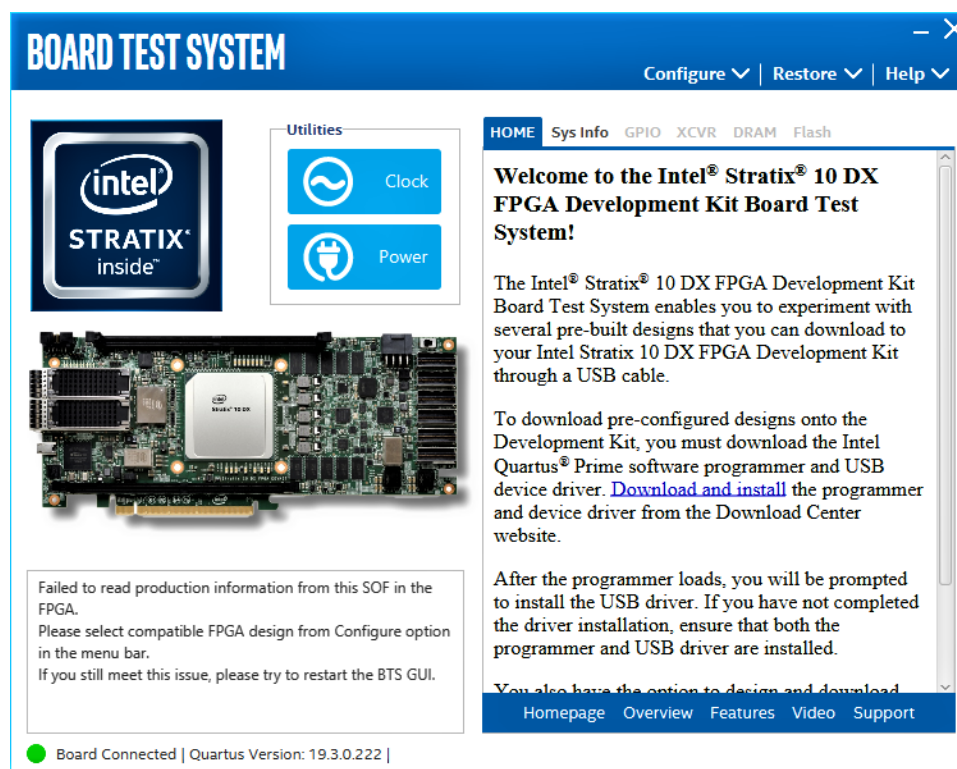
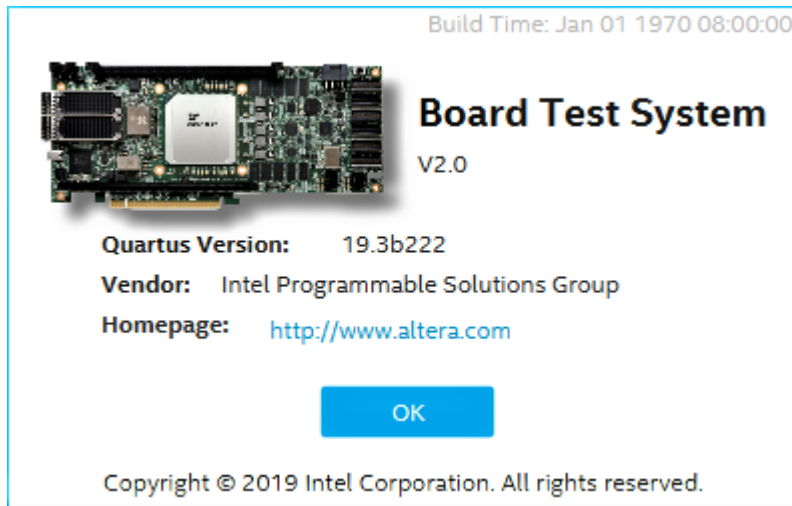

Figure 6. About BTS



4.1. Preparing the Development Kit

Several designs are provided to test the major board features. Each design provides data for one or more tabs in the application. The **Configure Menu** identifies the appropriate design to download to the FPGA for each tab.

After successful FPGA configuration, an appropriate tab appears that allows you to exercise the related board features. Highlights appear in the board picture around the corresponding components.

The BTS communicates over the JTAG bus to a test design running in the FPGA. The BTS and Power Monitor share the JTAG bus with other applications like the Nios® II debugger and the Signal Tap II Embedded Logic Analyzer. Because the BTS is designed based on the Intel Quartus Prime software, be sure to close other applications before you use the BTS.

The BTS relies on the Intel Quartus Prime software's specific library. Before running the BTS, open the Intel Quartus Prime software to automatically set the environment variable `$QUARTUS_ROOTDIR`. The BTS uses this environment variable to locate the Intel Quartus Prime library. The version of Intel Quartus Prime software set in the `QUARTUS_ROOTDIR` environment variable should be newer than version 14.1. For example, the Development Kit Installer version 15.1 requires that the Intel Quartus Prime software 14.1 or later version is installed.

Additionally, to ensure that the FPGA is configured successfully, you should install the latest Intel Quartus Prime software that can support the silicon on the development kit. For this board, Intel recommends installing the Intel Quartus Prime version 19.3 b222.

Refer to the `README.txt` file under `\examples\board_test_system` directory.

4.2. Running the Board Test System

With the power to the board turned off, follow these steps:

1. Connect the USB cable to your PC and the board.
2. Check whether the board switches and jumpers are set according to your preferences.
3. Turn on the power to the board.

To ensure operating stability, keep the USB cable connected and the board powered on when running the demonstration application. The BTS cannot run correctly unless the USB cable is attached and the board is powered on.

To run the BTS, navigate to the `<package_dir>\examples\board_test_system` directory and run the `BoardTestSystem.exe` application. A GUI appears, displaying the application tab corresponding to the design running in the FPGA. If the design loaded in the FPGA is not supported by the BTS GUI, you will receive a message prompting you to configure your board with a valid BTS design. Refer to the [Configure Menu](#) on page 17 for configuring your board.

If some design is running in the FPGA, the BTS GUI loads the design file (`.sof`) in the image folder to check the current running design in the FPGA. Therefore, the design running in the FPGA must be the same as the design file in the image folder.

4.3. Using the Board Test System

This section describes each tab in the BTS.

4.3.1. Configure Menu

Use the **Configure** menu to select the design you want to use. Each design example tests different board features. Select a design from this menu and the corresponding tabs become active for testing.

Figure 7. Configure Menu

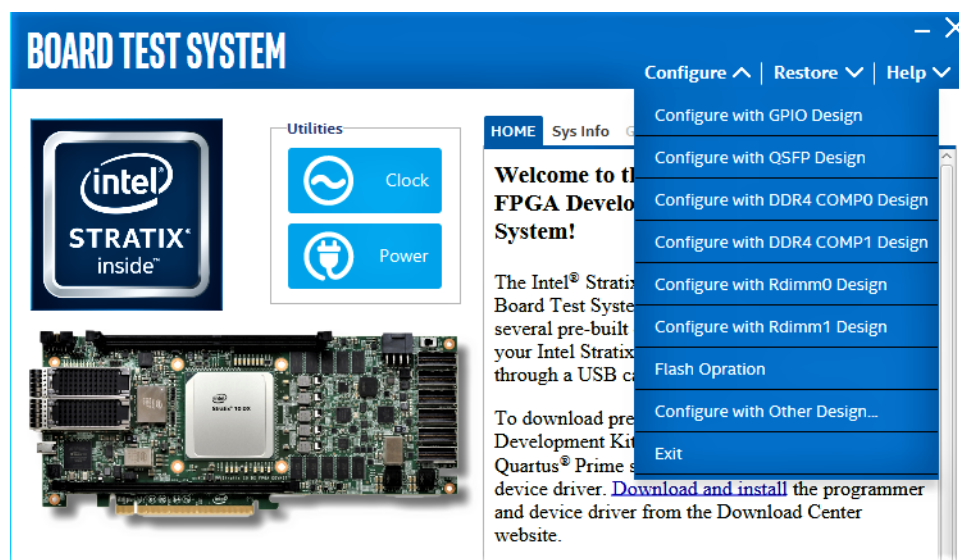

To configure the FPGA with a test system design, perform the following steps:

1. On the **Configure** menu, click the configure command that corresponds to the functionality you want to test.
2. In the dialog box that appears, click **Configure** to download the corresponding design to the FPGA.

When configuration finishes, close the Intel Quartus Prime software GUI if it's already open. The design begins running in the FPGA. The corresponding GUI application tabs that interface with the design are now enabled.

Note: If you use the Intel Quartus Prime Programmer for configuration rather than the BTS GUI, you may need to restart the GUI.

4.3.2. Sys Info Tab

The Sys Info tab shows the board's current configuration. The tab displays the contents of the Intel MAX 10 registers, the JTAG chain, the Ethernet port numbers, and other details stored on the board.

Figure 8. Sys Info Tab

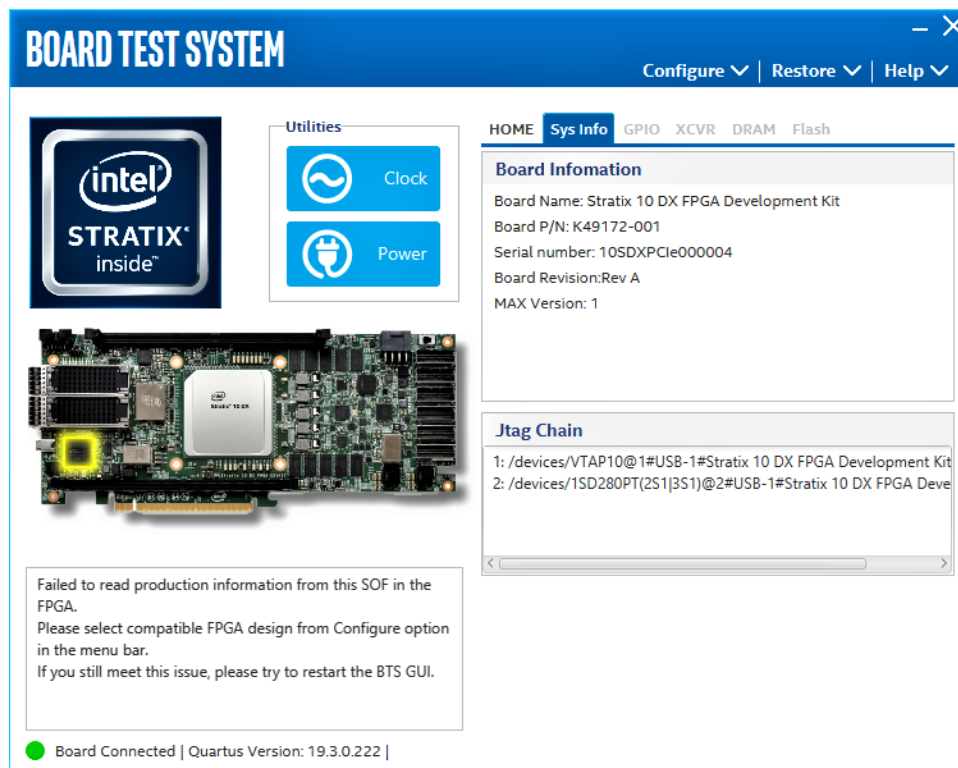

The following sections describe the controls of the **Sys Info** tab.

Board Information

Displays static information about your board:

- **Board Name:** Indicates the official name of the board given by the BTS.
- **Board P/N:** Indicates the part number of the board.
- **Serial Number:** Indicates the serial number of the board.
- **Board Revision:** Indicates the revision of the board.
- **MAX Version:** Indicates the version of Intel MAX 10 code currently running on the board.

JTAG Chain

Shows devices which are currently in the JTAG chain.

4.3.3. GPIO Tab

The **GPIO** tab allows you to interact with all the general purpose user I/O components on your board. You can turn LEDs on or off.

Figure 9. GPIO Tab

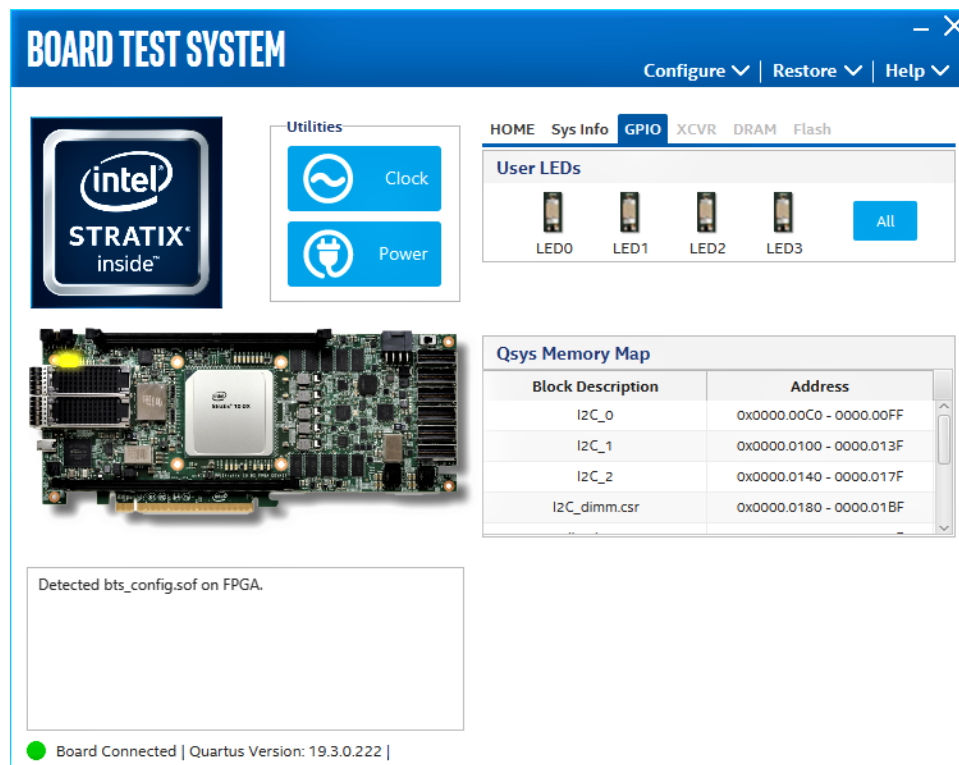

The following sections describe the controls on the **GPIO** tab:

User LEDs

Displays the current state of user LEDs. Toggle the LED buttons to turn the board LEDs on and off.

Qsys Memory Map

Shows the memory map of the GPIO or FLASH Platform Designer system on your board.

4.3.4. QSFP Tab

This tab allows you to perform loopback tests on the QSFP ports.

Figure 10. QSFP Tab

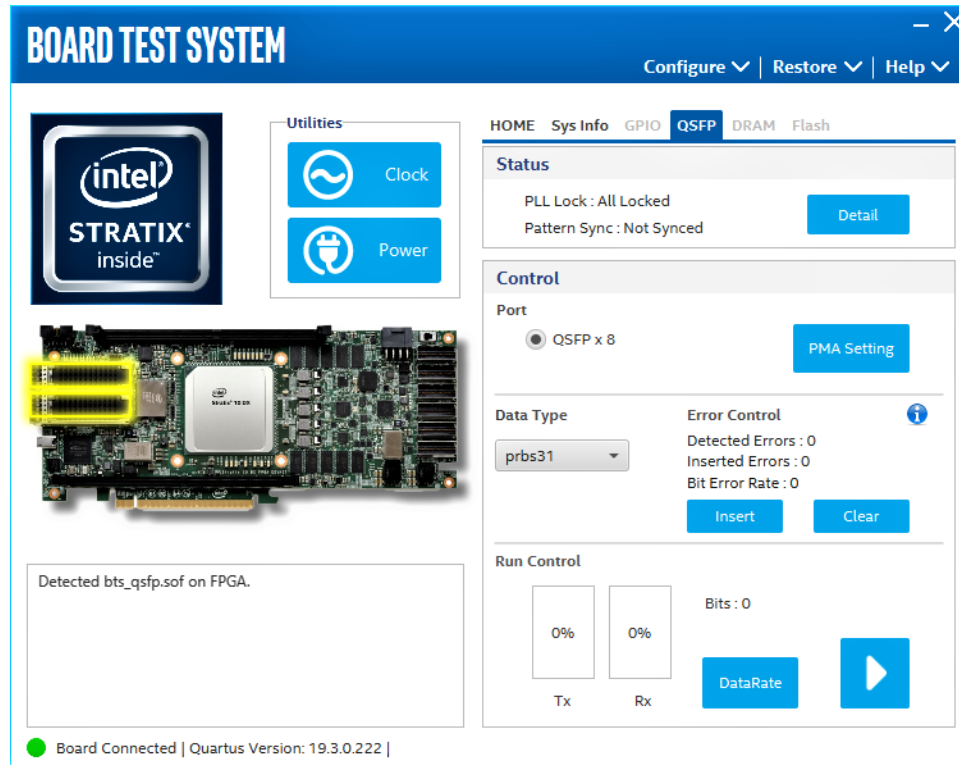

The following sections describe the controls on the **QSFP** tab:

Status

Displays the following status information during a loopback test:

- **PLL Lock:** Shows the PLL locked or unlocked state.
- **Pattern sync:** Shows the pattern synced or not synced state. The pattern is considered synced when the start of the data sequence is detected.
- **Details:** Shows the PLL lock and pattern sync status:

Figure 11. PLL and Pattern Status

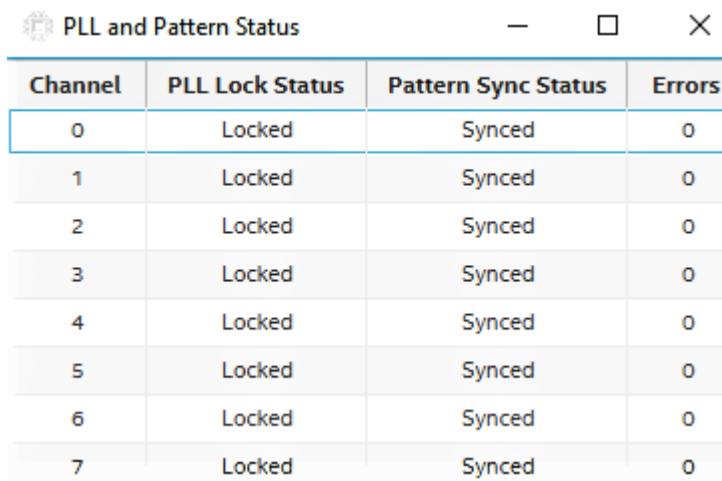

Channel	PLL Lock Status	Pattern Sync Status	Errors
0	Locked	Synced	0
1	Locked	Synced	0
2	Locked	Synced	0
3	Locked	Synced	0
4	Locked	Synced	0
5	Locked	Synced	0
6	Locked	Synced	0
7	Locked	Synced	0

Port

Allows you to specify which interface to test. The following port tests are available:

- QSFP x8

PMA Setting

Allows you to make changes to the PMA parameters that affect the active transceiver interface. The following settings are available for analysis:

- **Serial Loopback:** Routes signals between the transmitter and the receiver.
- **VOD:** Specifies the voltage output differential of the transmitter buffer.
- **Pre-emphasis tap:**
 - **Pre-tap 1:** Specifies the amount of pre-emphasis on the first pre-tap of the transmitter buffer.
 - **Pre-tap 2:** Specifies the amount of pre-emphasis on the second pre-tap of the transmitter buffer.
 - **Pre-tap 3:** Specifies the amount of pre-emphasis on the third pre-tap of the transmitter buffer.
 - **Post-tap 1:** Specifies the amount of pre-emphasis on the post-tap of the transmitter buffer.
- **Equalizer:** Specifies the RX tuning mode for receiver equalizer.

Figure 12. PMA Setting

Serial Loopback		Pre-emphasis tap					
		VOD	Pre-tap 1	Pre-tap 2	Pre-tap 3	Post-tap 1	Equalizer
<input type="checkbox"/>	All CH	8	0	0	0	10	Stop
<input type="checkbox"/>	CH0	8	0	0	0	10	Stop
<input type="checkbox"/>	CH1	8	0	0	0	10	Stop
<input type="checkbox"/>	CH2	8	0	0	0	10	Stop
<input type="checkbox"/>	CH3	8	0	0	0	10	Stop
<input type="checkbox"/>	CH4	8	0	0	0	10	Stop
<input type="checkbox"/>	CH5	8	0	0	0	10	Stop
<input type="checkbox"/>	CH6	8	0	0	0	10	Stop
<input type="checkbox"/>	CH7	8	0	0	0	10	Stop

Data Type

Specifies the type of data contained in the transactions. The following data types are available for analysis:

- **PRBS 7:** Selects pseudo-random 7-bit sequences.
- **PRBS 15:** Selects pseudo-random 15-bit sequences.
- **PRBS 23:** Selects pseudo-random 23-bit sequences.
- **PRBS 31:** Selects pseudo-random 31-bit sequences.
- **HF:** Selects highest frequency divide-by-2 data pattern 10101010.
- **LF:** Selects lowest frequency divide-by-33 data pattern.

Error Control

Displays data errors detected during analysis and allows you to insert errors:

- **Detected errors:** Displays the number of data errors detected in the hardware.
- **Inserted errors:** Displays the number of errors inserted into the transmit data stream.
- **Insert:** Inserts a one-word error into the transmit data stream each time you click the button. Insert is only enabled during transaction performance analysis.
- **Clear:** Resets the detected errors and inserted errors counters to zero.

Loopback

- **Start:** Initiates the selected ports transaction performance analysis. Always click **Clear** before Start.
- **Stop:** Terminates transaction performance analysis.
- **TX and RX performance bars:** Show the percentage of maximum theoretical data rate that the requested transactions are able to achieve.

4.3.5. Component DDR4 CH0 Tab

This tab allows you to read and write Component DDR4 CH0 memory on your board.

Figure 13. Component DDR4 CH0 Tab

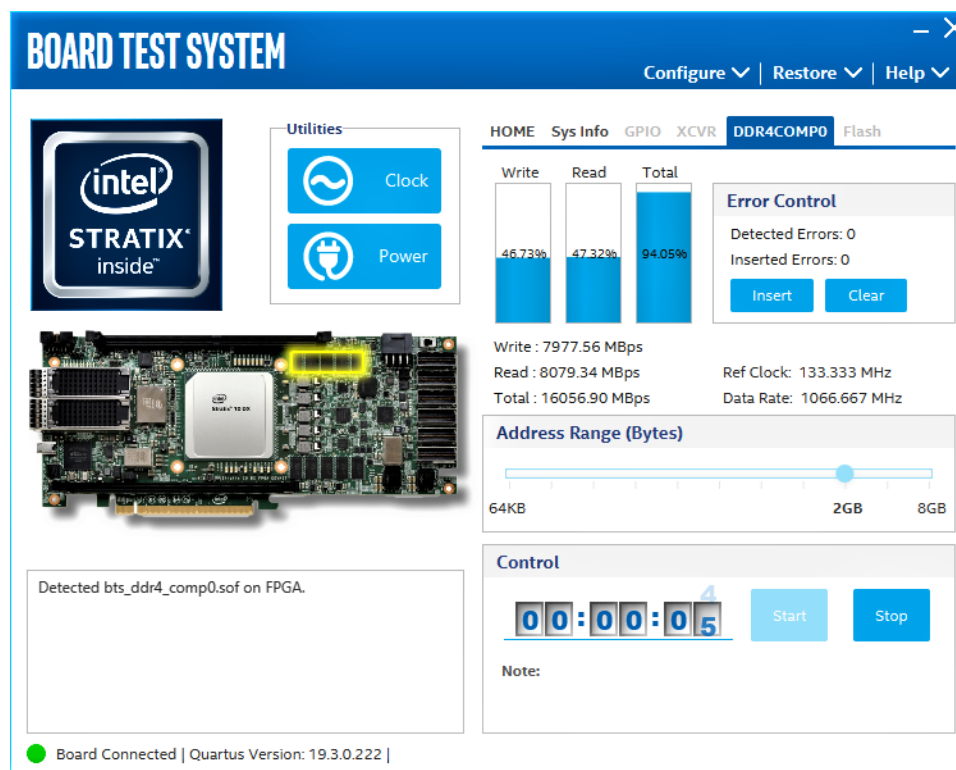

The following sections describe the controls on the **Component DDR4 CH0** tab:

Start

Initiates DDR4 memory transaction performance analysis.

Stop

Terminates transaction performance analysis.

Performance Indicator

These controls display current transaction performance analysis information collected since you last clicked Start:

- **Write, Read and Total performance bars:** Shows the percentage of maximum theoretical data rate that the requested transactions are able to achieve.
- **Write (MBps), Read (MBps) and Total (MBps):** Shows the number of bytes analyzed per second.
- **Data Bus:** 72-bits (8-bits ECC) wide and the frequency is 1066 MHz double data rate. 2133 Mbps per pin. Equating to a theoretical maximum bandwidth of 136,512 Mbps or 17,064 MBps.

Error Control

This control displays data errors detected during analysis and allows you to insert errors:

- **Detected errors:** Displays the number of data errors detected in the hardware.
- **Inserted errors:** Displays the number of errors inserted into the transaction stream.
- **Insert:** Inserts a one-word error into the transaction stream each time you click the button. Insert error is only enabled during transaction performance analysis.
- **Clear:** Resets the detected error and inserted error counters to zero.

Address Range

Determines the number of addresses to use in each iteration of reads and writes.

4.3.6. Component DDR4 CH1 Tab

This tab allows you to read and write Component DDR4 CH1 memory on your board.

Figure 14. Component DDR4 CH1 Tab

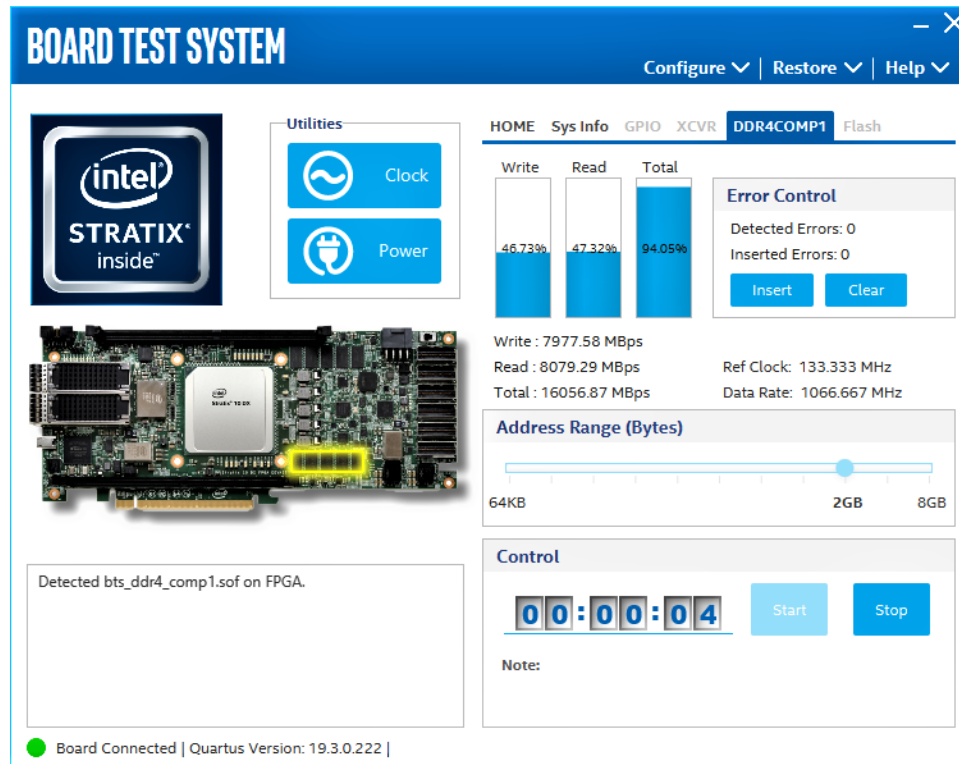

The following sections describe the controls on the **Component DDR4 CH1** tab.

Start

Initiates DDR4 memory transaction performance analysis.

Stop

Terminates transaction performance analysis.

Performance Indicators

These controls display current transaction performance analysis information collected since you last clicked Start:

- **Write, Read and Total performance bars:** Shows the percentage of maximum theoretical data rate that the requested transactions are able to achieve.
- **Write (MBps), Read (MBps) and Total (MBps):** Shows the number of bytes analyzed per second.
- **Data Bus:** 72-bits (8-bits ECC) wide and the frequency is 1066 MHz double data rate. 2133 Mbps per pin. Equating to a theoretical maximum bandwidth of 136,512 Mbps or 17,064 MBps.

Error Control

This control displays data errors detected during analysis and allows you to insert errors:

- **Detected errors:** Displays the number of data errors detected in the hardware.
- **Inserted errors:** Displays the number of errors inserted into the transaction stream.
- **Insert:** Inserts a one-word error into the transaction stream each time you click the button. Insert error is only enabled during transaction performance analysis.
- **Clear:** Resets the detected error and inserted error counters to zero.

Address Range

Determines the number of addresses to use in each iteration of reads and writes.

4.3.7. DDR4 DIMM CH0 Tab

This tab allows you to read and write Dual Inline Memory Module (DIMM) DDR4 CH0 memory on your board.

Figure 15. DDR4 DIMM CH0 Tab

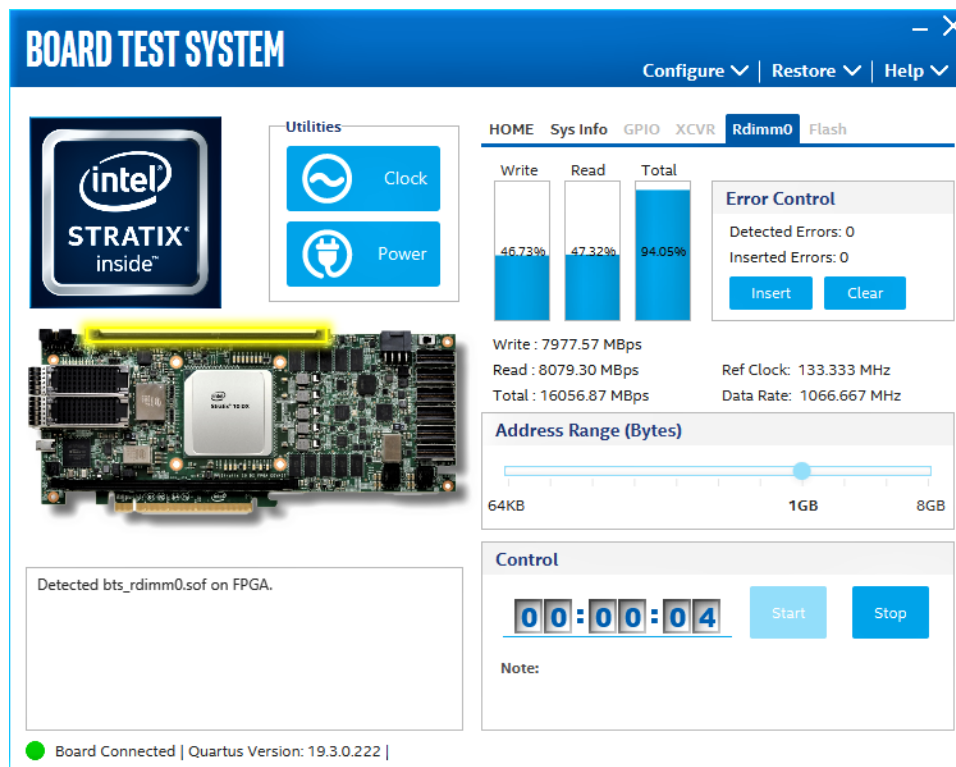

The following sections describe the controls on the **DDR4 DIMM CH0** tab:

Start

Initiates DDR4 memory transaction performance analysis.

Stop

Terminates transaction performance analysis.

Performance Indicators

These controls display current transaction performance analysis information collected since you last clicked Start:

- **Write, Read and Total performance bars:** Shows the percentage of maximum theoretical data rate that the requested transactions are able to achieve.
- **Write (MBps), Read (MBps) and Total (MBps):** Shows the number of bytes analyzed per second.
- **Data Bus:** 72-bits (8-bits ECC) wide and the frequency is 1066 MHz double data rate. 2133 Mbps per pin. Equating to a theoretical maximum bandwidth of 136,512 Mbps or 17,064 MBps.

Error Control

This control displays data errors detected during analysis and allows you to insert errors:

- **Detected errors:** Displays the number of data errors detected in the hardware.
- **Inserted errors:** Displays the number of errors inserted into the transaction stream.
- **Insert:** Inserts a one-word error into the transaction stream each time you click the button. Insert error is only enabled during transaction performance analysis.
- **Clear:** Resets the detected error and inserted error counters to zero.

Address Range

Determines the number of addresses to use in each iteration of reads and writes.

4.3.8. DDR4 DIMM CH1 Tab

This tab allows you to read and write Dual Inline Memory Module (DIMM) DDR4 CH1 memory on your board.

Figure 16. DDR4 DIMM CH1 Tab

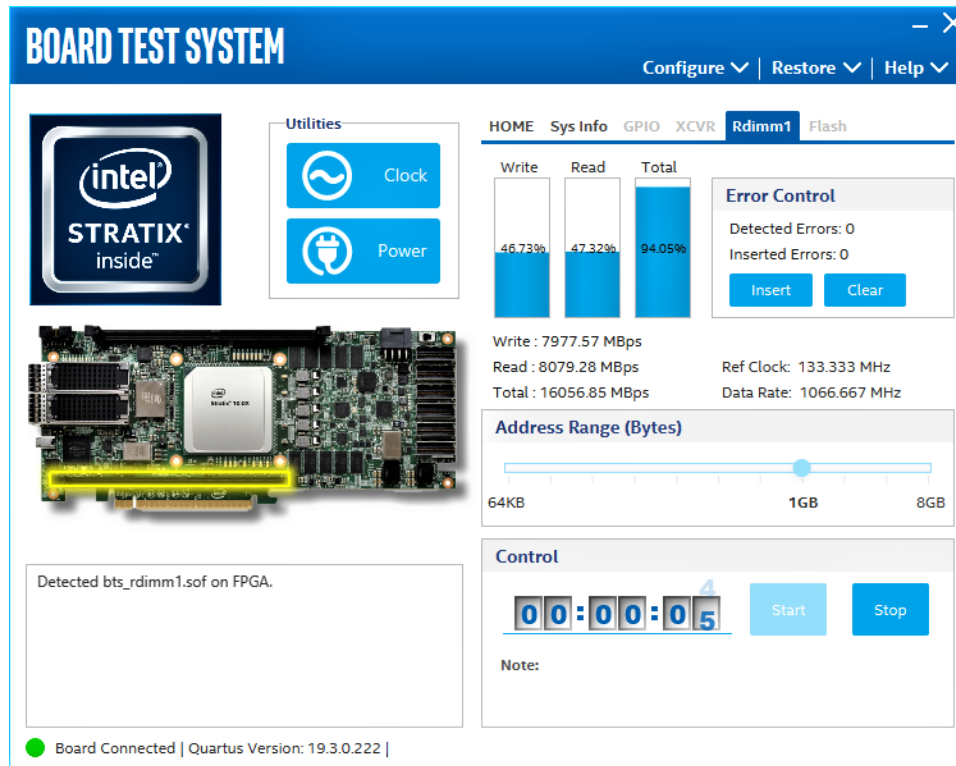

The following sections describe the controls on the **DDR4 DIMM CH1** tab:

Start

Initiates DDR4 memory transaction performance analysis.

Stop

Terminates transaction performance analysis.

Performance Indicators

These controls display current transaction performance analysis information collected since you last clicked Start:

- **Write, Read and Total performance bars:** Shows the percentage of maximum theoretical data rate that the requested transactions are able to achieve.
- **Write (MBps), Read (MBps) and Total (MBps):** Shows the number of bytes analyzed per second.
- **Data Bus:** 72-bits (8-bits ECC) wide and the frequency is 1066 MHz double data rate. 2133 Mbps per pin. Equating to a theoretical maximum bandwidth of 136,512 Mbps or 17,064 MBps.

Error Control

This control displays data errors detected during analysis and allows you to insert errors:

- **Detected errors:** Displays the number of data errors detected in the hardware.
- **Inserted errors:** Displays the number of errors inserted into the transaction stream.
- **Insert:** Inserts a one-word error into the transaction stream each time you click the button. Insert error is only enabled during transaction performance analysis.
- **Clear:** Resets the detected error and inserted error counters to zero.

Address Range

Determines the number of addresses to use in each iteration of reads and writes.

4.3.9. Power Monitor

The Power Monitor measures and reports current power information and communicates with the Intel MAX 10 device on the board through the JTAG bus. A power monitor circuit attached to the Intel MAX 10 device allows you to measure the power that the Intel Stratix 10 DX FPGA is consuming.

To start the application, click the **Power Monitor** icon in the BTS. You can also run the Power Monitor as a stand-alone application. The `PowerMonitor.exe` resides in the `<package_dir>\examples\board_test_system` directory.

Note: You cannot run the stand-alone power application and the BTS simultaneously. Also, you cannot run power and clock interface at the same time.

Figure 17. Power Monitor Interface

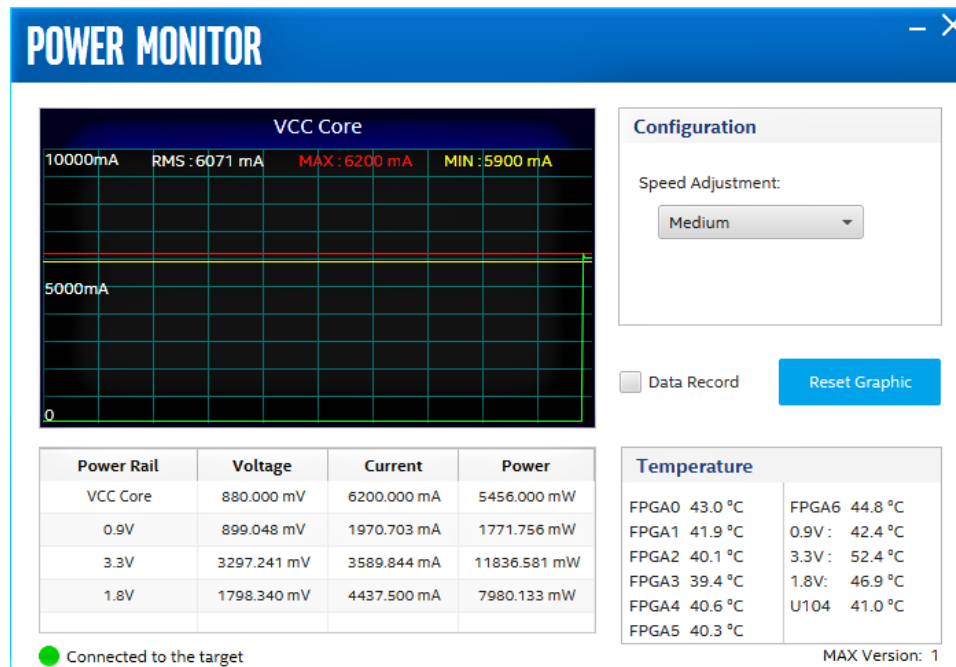

4.3.10. Clock Controller

The Clock Controller application sets the Si5391 programmable oscillators to any frequency between 0.16 MHz and 710 MHz.

The Clock Controller application sets the Si5332 programmable oscillators to any frequency between 0.1 MHz and 712.5 MHz.

The Clock Control communicates with the Intel MAX 10 on the board through the JTAG bus. The programmable oscillator are connected to the Intel MAX 10 device through a 2-wire serial bus.

Figure 18. Clock Controller - Si5391

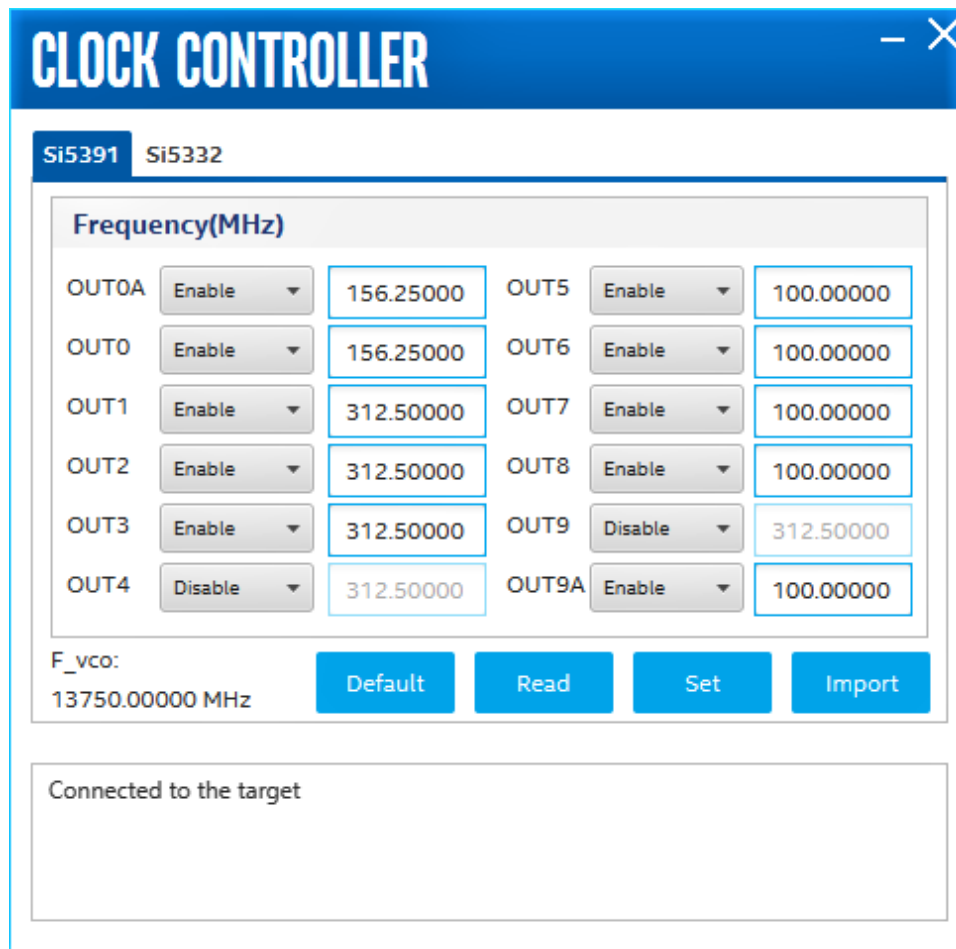
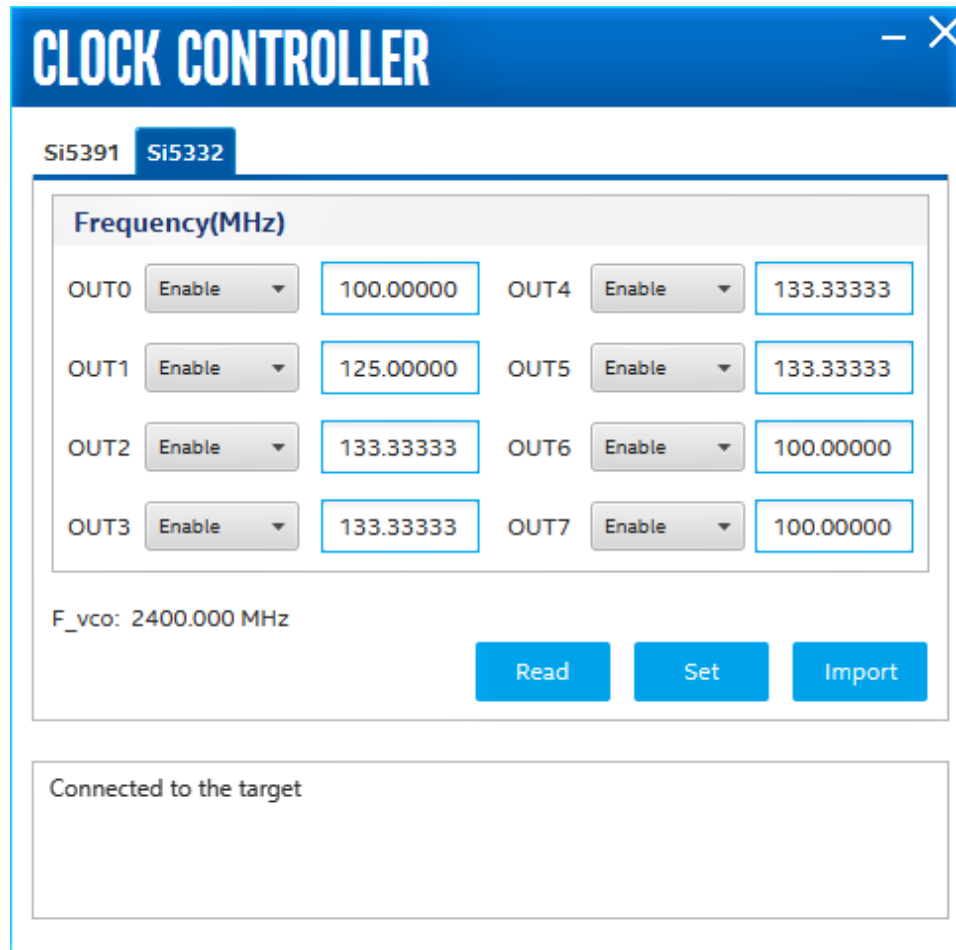

Figure 19. Clock Controller - Si5332



Si5391 tab and Si5332 tab display the same GUI controls for each clock generators. Each tab allows for separate control. The Si5391 is capable of synthesizing four independent user-programmable clock frequencies up to 710 MHz.

The controls of the clock controller are described below:

F_vco

Displays the generating signal value of the voltage-controlled oscillator.

Register

Display the current frequencies for each oscillator.

Frequency

Allows you to specify the frequency of the clock in MHz.

Read

Reads the current frequency setting for the oscillator associated with the active tab.

Default

Sets the frequency for the oscillator associated with the active tab back to its default value. This can also be accomplished by power cycling the board.

Set

Sets the programmable oscillator frequency for the selected clock to the value in the CLK0 to CLK3 controls for the Si5391. Frequency changes might take several milliseconds to take effect. You might see glitches on the clock during this time. Intel recommends resetting the FPGA logic after changing frequencies.

Import

Import register map file generated from Silicon Laboratories ClockBuilder Desktop.

4.4. Smart VID Setting

If you are creating your own design and want to generate programming .sof file, you must add the correct Smart VID Setting into Intel Quartus Prime project for Intel Stratix 10 DX FPGA Development Kit to make configuration successfully. Before you add the following Smart VID setting into the .qsf file, you must change the configuration scheme to Avalon® streaming interface x8 for your project. You can also extract the Smart VID setting from the Golden Top file.

For Intel Stratix 10 DX FPGA Development Kit (Production):

```

set_global_assignment -name USE_CONF_DONE SDM_IO16
set_global_assignment -name USE_CVP_CONFDONE SDM_IO5
set_global_assignment -name VID_OPERATION_MODE "PMBUS MASTER"
set_global_assignment -name USE_PWRMGT_SCL SDM_IO0
set_global_assignment -name USE_PWRMGT_SDA SDM_IO12
set_global_assignment -name PWRMGT_BUS_SPEED_MODE "100 KHZ"
set_global_assignment -name PWRMGT_SLAVE_DEVICE_TYPE ED8401
set_global_assignment -name PWRMGT_SLAVE_DEVICE0_ADDRESS 49
set_global_assignment -name PWRMGT_SLAVE_DEVICE1_ADDRESS 00
set_global_assignment -name PWRMGT_SLAVE_DEVICE2_ADDRESS 00
set_global_assignment -name PWRMGT_SLAVE_DEVICE3_ADDRESS 00
set_global_assignment -name PWRMGT_SLAVE_DEVICE4_ADDRESS 00
set_global_assignment -name PWRMGT_SLAVE_DEVICE5_ADDRESS 00
set_global_assignment -name PWRMGT_SLAVE_DEVICE6_ADDRESS 00
set_global_assignment -name PWRMGT_SLAVE_DEVICE7_ADDRESS 00
set_global_assignment -name PWRMGT_VOLTAGE_OUTPUT_FORMAT "LINEAR FORMAT"
set_global_assignment -name PWRMGT_LINEAR_FORMAT_N "-13"
set_global_assignment -name PWRMGT_TRANSLATED_VOLTAGE_VALUE_UNIT VOLTS
set_global_assignment -name PWRMGT_PAGE_COMMAND_ENABLE OFF

```

For Intel Stratix 10 DX FPGA Development Kit (ES1):

```

set_global_assignment -name USE_CONF_DONE SDM_IO16
set_global_assignment -name USE_CVP_CONFDONE SDM_IO5
set_global_assignment -name VID_OPERATION_MODE "PMBUS MASTER"
set_global_assignment -name USE_PWRMGT_SCL SDM_IO0
set_global_assignment -name USE_PWRMGT_SDA SDM_IO12
set_global_assignment -name PWRMGT_BUS_SPEED_MODE "100 KHZ"
set_global_assignment -name PWRMGT_SLAVE_DEVICE_TYPE OTHER
set_global_assignment -name PWRMGT_SLAVE_DEVICE0_ADDRESS 60
set_global_assignment -name PWRMGT_SLAVE_DEVICE1_ADDRESS 00
set_global_assignment -name PWRMGT_SLAVE_DEVICE2_ADDRESS 00
set_global_assignment -name PWRMGT_SLAVE_DEVICE3_ADDRESS 00
set_global_assignment -name PWRMGT_SLAVE_DEVICE4_ADDRESS 00
set_global_assignment -name PWRMGT_SLAVE_DEVICE5_ADDRESS 00
set_global_assignment -name PWRMGT_SLAVE_DEVICE6_ADDRESS 00

```

4. Board Test System (BTS)

683561 | 2020.11.16



```
set_global_assignment -name PWRMGT_SLAVE_DEVICE7_ADDRESS 00
set_global_assignment -name PWRMGT_VOLTAGE_OUTPUT_FORMAT "DIRECT FORMAT"
set_global_assignment -name PWRMGT_DIRECT_FORMAT_COEFFICIENT_M 1
set_global_assignment -name PWRMGT_DIRECT_FORMAT_COEFFICIENT_R 3
set_global_assignment -name PWRMGT_TRANSLATED_VOLTAGE_VALUE_UNIT VOLTS
set_global_assignment -name PWRMGT_PAGE_COMMAND_ENABLE OFF
```

5. Development Kit Hardware and Configuration

5.1. FPGA Configuration

Prerequisites:

- Install the Intel Quartus Prime Pro Edition and Intel FPGA Download Cable II driver on the host computer.
- Connect the micro-USB cable to the Intel Stratix 10 DX FPGA Development Kit.
- Power-on the board. Ensure that no running application is using the JTAG chain.

Follow these steps to configure the FPGA with your SRAM Object File (.sof) using the Intel Quartus Prime Pro Edition Programmer:

1. Start the Intel Quartus Prime Pro Edition Programmer.
2. Click **Auto Detect** to display the devices in the JTAG chain.
3. Click **Change File** and select the path to the desired *.sof file.
4. Turn on the **Program or Configure** option for the added file.
5. Click **Start** to download the selected file to the FPGA. The configuration is completed successfully when the progress bar reaches 100%.

Using the Intel Quartus Prime Pro Edition Programmer to configure a device on the board causes other JTAG- based applications such as the Board Test System and the Power Monitor to lose their connection to the board. Restart those applications after the configuration is complete.

Note: While using the Intel Quartus Prime Pro Edition software version 19.3, you may observe occasional crash. Contact Intel support to access additional patch (0.01) for Intel Quartus Prime Pro Edition Programmer to mitigate this issue.

5.2. Programming the FPGA Over Intel FPGA Download Cable

The figure below shows the high-level conceptual block diagram for programming the Intel Stratix 10 DX FPGA over the embedded Intel FPGA Download Cable or external Intel FPGA Download Cable.

Figure 20. Programming Concept Block Diagram

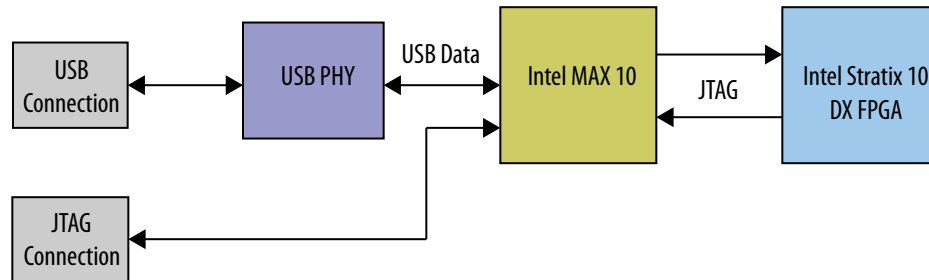

5.3. Configuration Modes

The Intel Stratix 10 DX FPGA Development Kit supports two configuration modes:

- **Avalon Streaming Interface x8** - using the 2Gb QSPI Flash device (U66)
- **JTAG** - using either the embedded Intel FPGA Download Cable or external Intel FPGA Download Cable.

5.3.1. Avalon Streaming Interface x8 Mode

The SDM block in the Intel Stratix 10 DX FPGA device controls the configuration process and interface. The Intel MAX 10 System Controller (U11) interfaces to Intel Stratix 10 DX FPGA in Avalon Streaming Interface X8 mode.

For Avalon Streaming Interface x8 mode, the MSEL[2:0] configuration pin strapping (SW1) must be set to [110] (which means SW1.1: ON (Close), SW1.2: OFF (Open), SW1.3: OFF (Open)).

5.3.1.1. Avalon Streaming Interface x8 Configuration Guideline

Ensure the following conditions are met before you proceed:

- The Intel Quartus Prime Programmer and the Intel FPGA Download Cable II driver are installed on the host computer.
- If you are using an external JTAG programmer, ensure the Intel FPGA Download Cable II is connected to the board through the 10-pin female connector. Verify that the Intel FPGA Download Cable II LED for proper connection to the host computer through a micro-USB cable.
- Power to the board is on, and no other applications that use the JTAG chain are running.

Avalon Streaming Interface x8 Programmer Object File (.pof) Generation using the Intel Quartus Prime Pro Edition software version 20.1 or later

Note: If you already have the Programmer Object File (.pof), you can skip this section.

1. Open the Intel Quartus Prime Pro Edition software and click on **File > Programming File Generator** to launch **Programming File Generator** tool.
2. In the **Device Family** list, select **Stratix 10**, and in the **Configuration mode** list, select **AVST x8** to specify the device and configuration mode.

3. In the **Output directory** tab, click **Browse** to specify the output directory for .pof file, in the **Name** column, input filename for .pof file.
4. In the **Description** column, select the **Programmer Object File (.pof)** and **Memory Map File (.map)** option.

Figure 21. Step 2 to 4 Illustration

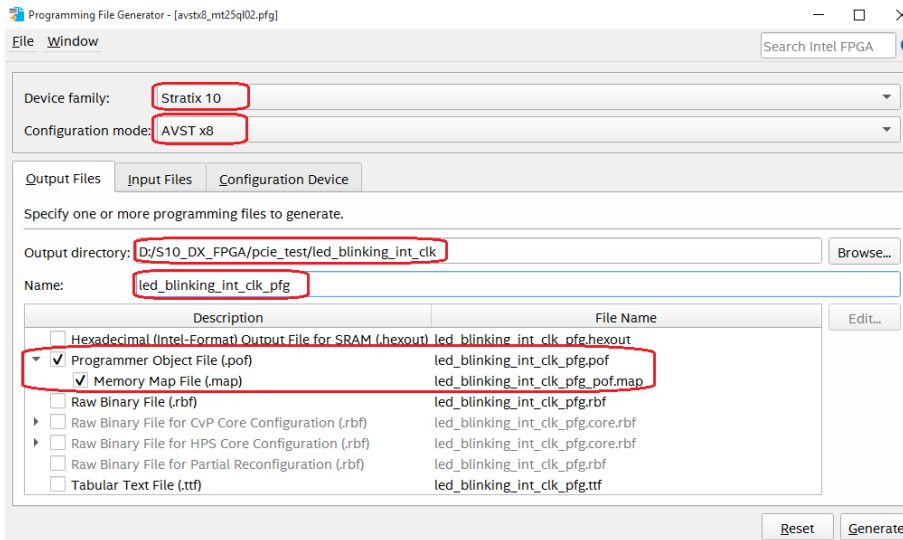

5. Click on **Input Files>Add Bitstream** tab to specify a .sof that contains the configuration bitstream.

Figure 22. Step 5 Illustration

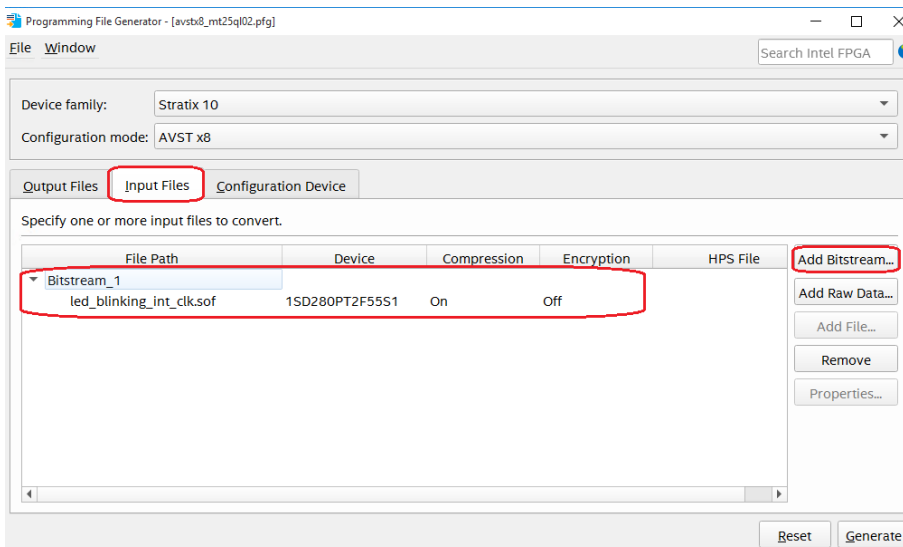

6. Click on **Configuration Device>Add Device** to specify the flash device. In the **Device** list of the pop-up window, select **CFI_2Gb** for the configuration flash device.

7. Click on **OPTIONS** row, and then click on **Edit** option to modify the start address. In the **Address Mode** list of the pop-up window, select **Start**; in the **Start address** list, input **0x00010000**.

Figure 23. Step 7 Illustration

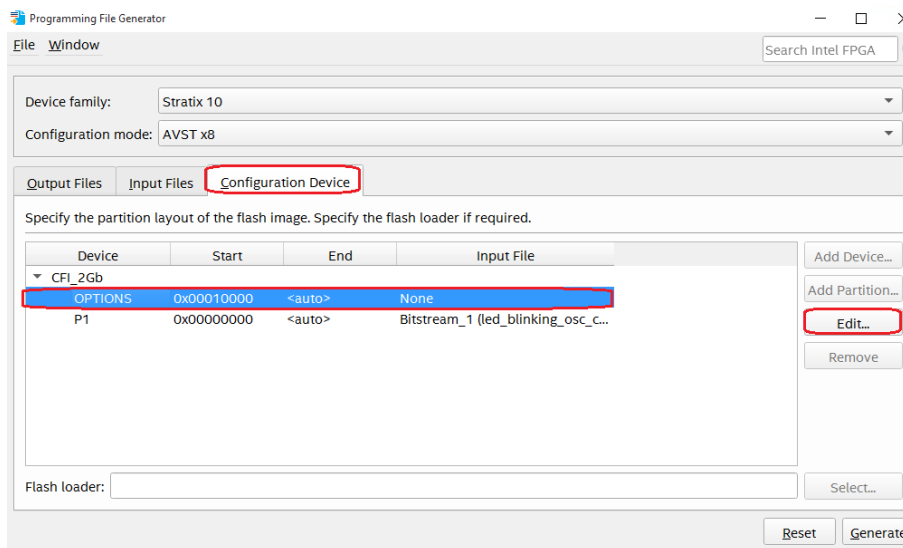

8. Click on **CFI_2Gb** row, and then click **Add Partition** option. In the **Input file** list of pop-up window, select **Bitstream (input_sof_file.sof)**; in the **Address Mode** list of pop-up window, select **Start**; in the **Start address** list, input **0x00100000**.

Figure 24. Step 8 Illustration

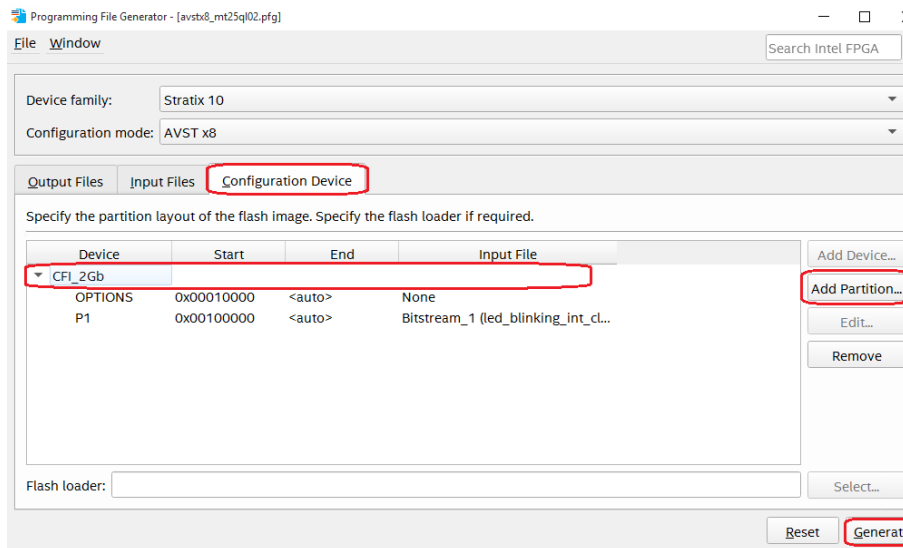

9. Click **Generate** to generate the .pof file.

Avalon Streaming Interface x8 Programmer Object File (.pof) Generation using the Intel Quartus Prime Pro Edition software version 19.3 or 19.4

The `avstx8.cof` and `avstx8.cdf` are included in the `factory_recovery` folder of installer package.

Note: If you already have the Programmer Object File (.pof), you can skip this section.

1. Open `avstx8.cof` using the text editor.
2. Change the `.pof` file name and directory based on your local output file name and directory, the location is marked as **1** in the figure below.
3. Change the `.sof` file name and directory based on your local input file name and directory, the location is marked as **2** in the figure below.

Figure 25. Step 2 and 3 Illustration

```

1  <?xml version="1.0" encoding="US-ASCII" standalone="yes"?>
2  <cof>
3  <eprom name>CFI_2GB</eprom name>
4  <output_filename>C:/Laptop/Debug/S10_DX_FPGA/led_blinking/19.2/avstx8.pof</output_filename>
5  <n_pages>1</n_pages>
6  <width>1</width>
7  <mode>20</mode>
8  <sof_data>
9  <start_address>00100000</start_address>
10 <user_name>Page_0</user_name>
11 <page_flags>1</page_flags>
12 <bit0>
13 <sof_filename>C:/Laptop/Debug/S10_DX_FPGA/led_blinking/19.2/bts_config.sof</sof_filename>
14 </bit0>
15 </sof_data>
16 <version>10</version>
17 <create_cvp_file>0</create_cvp_file>
18 <create_hps_iocsr>0</create_hps_iocsr>
19 <auto_create_rpd>0</auto_create_rpd>
20 <rpdc_little_endian>1</rpdc_little_endian>
21 <options>
22 <map_file>1</map_file>
23 <option_start_address>10000</option_start_address>
24 <dynamic_compression>0</dynamic_compression>
25 </options>
26 <advanced_options>
27 <ignore_epcs_id_check>1</ignore_epcs_id_check>
28 <ignore_condone_check>2</ignore_condone_check>
29 <plc_adjustment>0</plc_adjustment>
30 <post_chain_bitstream_pad_bytes>-1</post_chain_bitstream_pad_bytes>
31 <post_device_bitstream_pad_bytes>-1</post_device_bitstream_pad_bytes>
32 <bitslice_pre_padding>1</bitslice_pre_padding>
33 </advanced_options>
34 </cof>
  
```

4. Save the change and close the `avstx8.cof` file.
5. Open the Intel Quartus Prime Pro Edition software 19.3 or later version, and click on **File > Convert Programming Files** to launch **Convert Programming File** tool.
6. Click on **Open Conversion Setup Data** to locate the recently saved `avstx8.cof` file and open it.

Figure 26. Step 6 Illustration

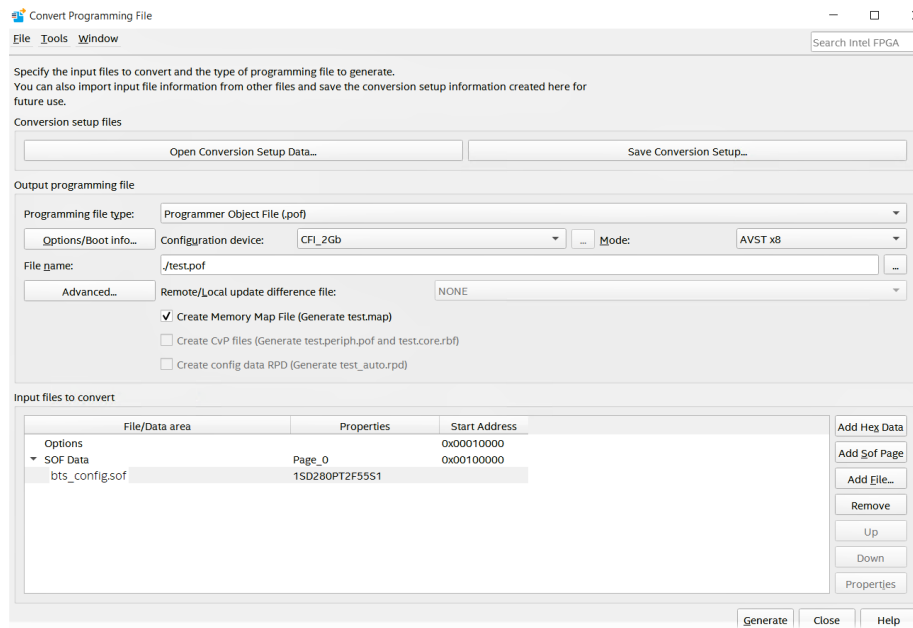

7. Click **Generate** to generate the .pof file.

QSPI Flash Programming with Avalon Streaming Interface x8 Configuration Testing

1. Open avstx8.cdf using the text editor.
2. Change the .pof file name and directory based on your local output file name and directory, the location is marked as **1** in the figure below. Ensure to save the file.

Figure 27. Step 2 Illustration

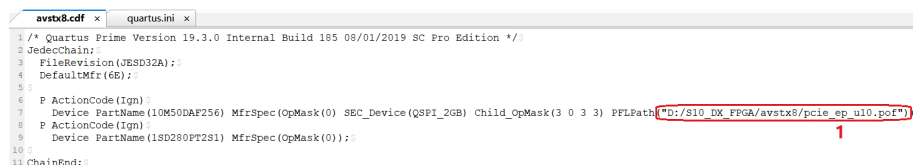

3. Change switch **SW33.1** to OFF (1'b0:far from board edge) position for normal JTAG mode.
4. Plug in the USB dongle to external JTAG header (**J2**) or plug in the USB cable into micro USB port (**CN1**).
5. Plug ATX Power into **J42**, switch **SW31** to turn ON the Intel Stratix 10 FPGA power.
6. Open the Intel Quartus Prime Pro Edition software 19.3 or later version, and open avstx8.cdf file.

Figure 28. Step 6 Illustration

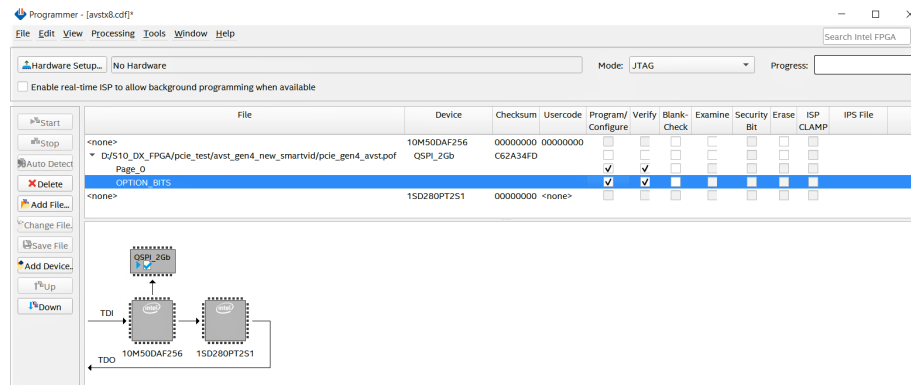

- Click on **Hardware Setup** in the Intel Quartus Prime Programmer to change **Hardware frequency** to 16 MHz.

Use the following command to change TCK frequency to 16 MHz:

```
jtagconfig --setparam <cable_number> JtagClock 16M
```

- Click on **Start** to start QSPI Flash programming.
- After programming is successful, change switch **SW31** to power OFF, and unplug the ATX power from **J42** to completely power down the development kit. Change the **MSEL(SW1)** to 110 (AVSTx8, **SW1.1**: ON (Close), **SW1.2**: OFF (Open), **SW1.3**: OFF (Open))

Note: If the development kit is installed in the server, you must power off the server and power it on to completely power cycle the development kit.

- Plug ATX Power into J42 and change switch **SW31** to power ON the development kit. Observe whether the **D57** is ON (ON means the AVST x8 configuration is successful).

5.3.2. JTAG Mode

The JTAG Switch implemented in the Intel MAX 10 System Control (U11) allows the selection of the device(s) to be included in the JTAG chain. It is done by the settings of the DIP switch SW33. The embedded Intel FPGA Download Cable (or external Intel FPGA Download Cable) or PCIe JTAG can be selected as the source for programming the device(s) on the chain. The embedded Intel FPGA Download Cable is the default setting for this configuration mode.

Figure 29. JTAG Chain

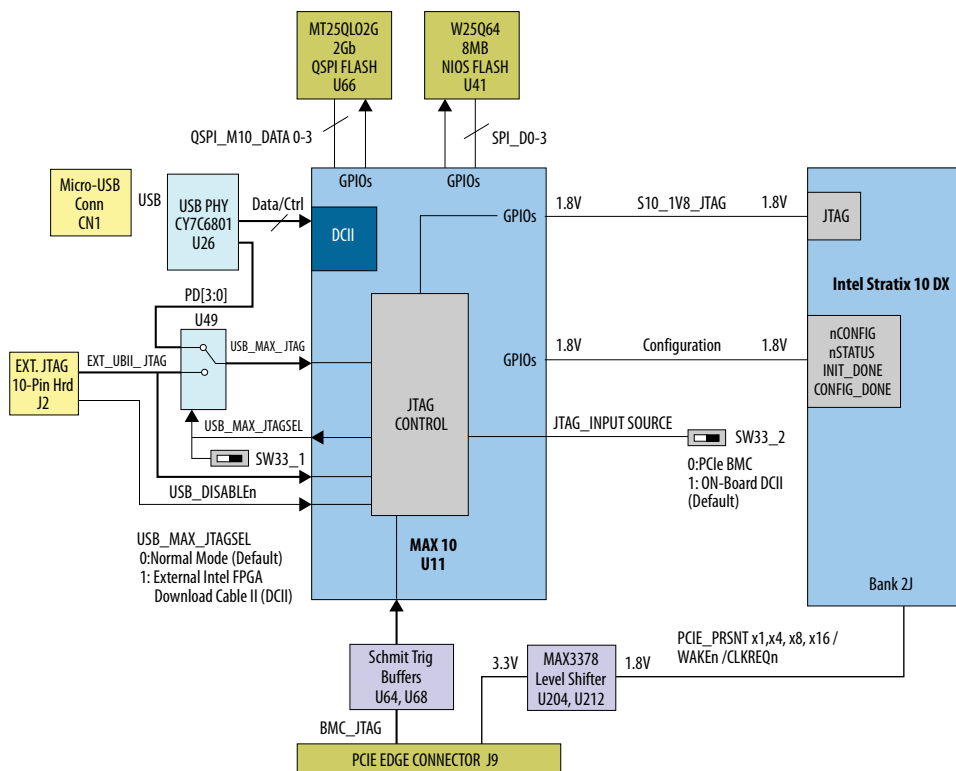

The on-board Intel FPGA Download Cable is implemented in a Intel MAX 10 device. A micro-USB connector connecting to a CY7C68013A USB2 PHY provides the data to Intel MAX 10 device. This allows you to configure the FPGA using a USB cable, which is directly connected to a host PC running Intel Quartus Prime Pro Edition software without requiring the external Intel FPGA Download Cable.

You can also use the external Intel FPGA Download Cable on J2 to configure the FPGA.

6. Document Revision History for Intel Stratix 10 DX FPGA Development Kit User Guide

Document Version	Changes
2020.11.16	Clarified the Smart VID Setting for ES1 and Production version of the Intel Stratix 10 DX FPGA Development Kit.
2020.11.04	Sections updated: <ul style="list-style-type: none"> • About this Document on page 4 • Default Switch Settings on page 9 • Connectors and LEDs on page 12 • Smart VID Setting on page 32 • Development Kit Components on page 43 • Components Overview on page 44 • Power Distribution on page 49 • Power Measurement on page 52 • I2C Interface on page 66
2020.08.17	Clarified the default position for Switch Settings.
2020.04.20	Updated steps in section: <i>Avalon Streaming Interface x8 Programmer Object File (.pof) Generation</i> .
2019.12.09	Initial release.

A. Development Kit Components

This appendix provides detailed information about the Intel Stratix 10 DX FPGA Development Kit components.

Figure 30. Development Kit Front

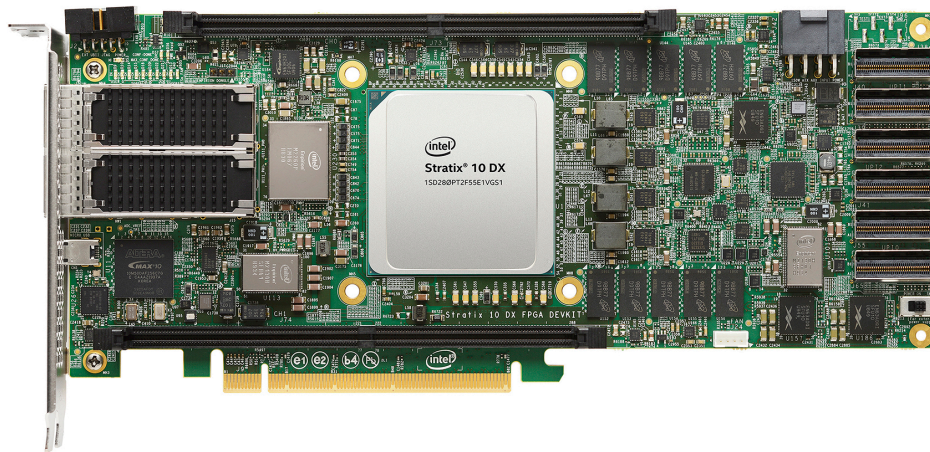
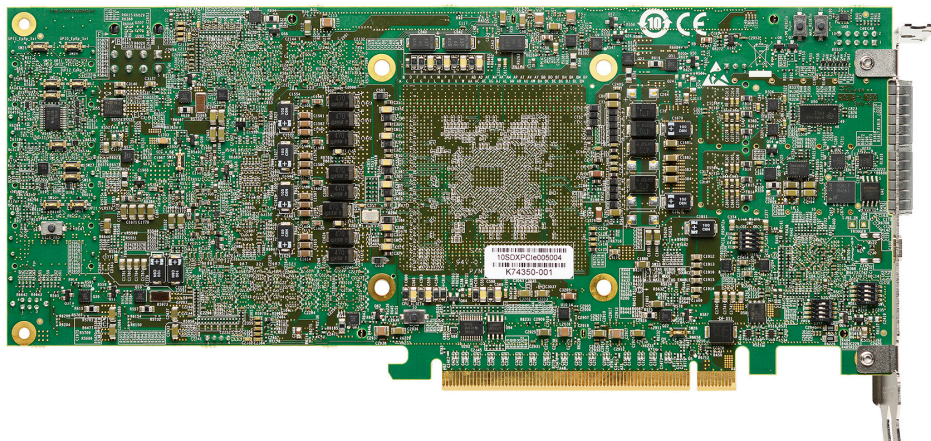

Figure 31. Development Kit Back



Intel Corporation. All rights reserved. Intel, the Intel logo, and other Intel marks are trademarks of Intel Corporation or its subsidiaries. Intel warrants performance of its FPGA and semiconductor products to current specifications in accordance with Intel's standard warranty, but reserves the right to make changes to any products and services at any time without notice. Intel assumes no responsibility or liability arising out of the application or use of any information, product, or service described herein except as expressly agreed to in writing by Intel. Intel customers are advised to obtain the latest version of device specifications before relying on any published information and before placing orders for products or services.

*Other names and brands may be claimed as the property of others.

A.1. Components Overview

Table 8. Intel Stratix 10 DX FPGA Development Kit Components

Board Reference	Component	Description
Featured Devices		
U1	Intel Stratix 10 DX FPGA	<ul style="list-style-type: none"> Logic elements: 2.8M DSP blocks: 5760 M20K memory blocks: 11721 Package type: 2912 BGA Transceiver count: 84 <ul style="list-style-type: none"> 4x P-Tile supporting PCIe X16 Gen4 (16 Gb/s) or UPI X 20 (1up to 11.2 GT/s) 1x E-Tile transceiver supporting 2x 56Gbps PAM4 or 4x 25Gbps NRZ
U11	Intel MAX 10	<ul style="list-style-type: none"> Logic elements: 50K Package type: 256 FBGA 1.8V VCCINT
Clock Circuits		
X4	Intel MAX 10 Reference Clock	<p>The crystal oscillator provides the reference clock for Intel MAX 10 device:</p> <ul style="list-style-type: none"> Out = 125.00 MHz
U7	Programmable Clock Generator Si5332A	<p>Default frequencies:</p> <ul style="list-style-type: none"> Out0 = 100.00 MHz Out1 = 125.00 MHz Out2 = 133.333MHz Out3 = 133.333MHz Out4 = 133.333 MHz Out5 = 133.333MHz Out6 = 100.00 MHz Out7 = 100.00MHz
U9	Programmable Clock Generator Si5391A	<p>Default frequencies:</p> <ul style="list-style-type: none"> CLK0 = 156.25MHz CLK0A = 156.25 MHz CLK1 = 312.50 MHz CLK2 = 312.50 MHz CLK3 = 312.50 MHz CLK4 = Not used CLK5 = Not used CLK6 = 100.00 MHz CLK7 = 100.00 MHz CLK8 = 100.00 MHz CLK9 = 100.00 MHz CLK9A = 100.00 MHz
Transceiver Interfaces		
J9	PCIe x16 gold fingers	PCIe TX/RX x16 interface from FPGA P-tile 10A
J38	PCIe x16 or UPI x20, Link 1	PCIe/UPI Transmit interface from FPGA P-tile 11B
J40	PCIe x16 or UPI x20, Link 1	PCIe/UPI Receive interface from FPGA P-tile 11B
J39	PCIe x16 or UPI x20, Link 2	PCIe/UPI Transmit interface from FPGA P-tile 11C
<i>continued...</i>		

Board Reference	Component	Description
J41	PCIe x16 or UPI x20, Link 2	PCIe/UPI Receive interface from FPGA P-tile 11C
J55	PCIe x16 or UPI x20, Link 0	PCIe/UPI Transmit interface from FPGA P-tile 10B
J65	PCIe x16 or UPI x20, Link 0	PCIe/UPI Receive interface from FPGA P-tile 10B
J15	QSFP 1 connector	Four TX/RX channels from FPGA Bank 4F
J18	QSFP 2 connector	Four TX/RX channels from FPGA Bank 4F
General User Input/Output		
D9, D10, D14, D15	User defined LEDs	Four green-color user LEDs. Illuminates when driven low
Memory		
J73	DDR4 x72 DIMM connector	One X72 memory interface supporting DDR4 (x72) or Intel Optane DC Persistent memory module: <ul style="list-style-type: none"> • DDR4 memory (x72) 1333 MHz • Intel Optane DC Persistent memory (requires memory controller IP core)
J74	DDR4 x72 DIMM connector	One X72 memory interface supporting DDR4 (x72) or Intel Optane DC Persistent memory module: <ul style="list-style-type: none"> • DDR4 memory (x72) 1333 MHz • Intel Optane DC Persistent memory (requires memory controller IP core)
U142, U143, U144, U145, U146	On-board DDR4 x72 Memory interface	This on-board DDR4 x72 memory supports 8 GB at up to 1200 MHz
U152, U153, U154, U155, U156	On-board DDR4 x72 Memory interface	This on-board DDR4 x72 memory supports 8 GB at up to 1200 MHz
U41	NIOS Flash 64K-bit	This on-board Flash is for Intel MAX 10
U66	QSPI 2 Gbit NOR Flash	This on-board Flash is for image storage for FPGA
Communication Ports		
J9	PCI Express x16 edge connector	Gold-plated edge fingers for up to x16 signaling in either Gen1, Gen2, Gen3, or Gen4 mode
J15	QSFP 1 Interface	Provides four transceiver channels for a 100G QSFP module
J18	QSFP 2 Interface	Provides four transceiver channels for a 100G QSFP module
J97	I2C/PMBus connector	For accessing core power controller
J17	I2C connector	For accessing the I2C1 bus
J2	External JTAG Port	This port allows the use of Intel FPGA Download Cable II dongle to access the JTAG links on the board. Connection to this port automatically disables the internal Intel FPGA Download Cable II JTAG.
CN1	Micro-USB connector	Embedded Intel Intel FPGA Download Cable II JTAG for programming the FPGA via USB cable.
Power Supply		
J9	PCI Express edge connector	Interfaces to a PCI Express root port such as an appropriate PC motherboard for 12V power source
J42	DC input jack	Accepts a 12 V DC power supply when powering the board from the provided power brick for lab bench operation.

continued...

Board Reference	Component	Description
		When operating from the PCIe slot, this input must also be connected to the 8-pin Aux PCIe power connector provided by the PC system along with J42, or else the board will not power on.
SW31	Power switch	Switch to power ON or OFF the board when supplied from the DC input jack
U217	12V Hot Swap Controller	Provide protection for AUX power input (J42)
U96	12V Hot Swap Controller	Provide protection for PCIe slot power input (J9)
U93	Controlled power FET	Perform power bridging function between AUX2 and PCIe slot when the board is not used in PCIe system
U101	3.3V Voltage regulator	Provides 3.3V to power system
U99	5V Voltage regulator	Provides 5V to power system
U47,U240,U77,U241,U242	4-phase VCC Core Voltage regulator	Provides power to VCC core of Intel Stratix 10 FPGA
U230	0.9V Voltage regulator	Provides power to all power rails in Group 1
U113	1.8V Voltage regulator	Provides power to VCCPT and other rails in Group 2
U186	1.8V Voltage regulator	Provides power to VCCH and VCCCLK for P-tiles
U184	1.1V Voltage regulator	Provides power to VCCH for E-tile
U78	2.5V Voltage regulator	Provides power to VCCCLK for E-tile
U76	2.4V Voltage regulator	Provides power to VCCFUSEWR_SDM of Intel Stratix 10 FPGA
U188	1.8V Voltage regulator	Provides power to VCCIO of Intel Stratix 10 FPGA
U116	1.2V and 2.5V Voltage regulator	Provides power to Intel MAX 10 core and other rails
U79	1.8V Voltage regulator	Provides power to VCCIO of Intel MAX 10
U163	2.5V Voltage regulator	Provides power to DDR4 Channel 0
U164	0.6V Voltage regulator	Provides power to DDR4 VTT Channel 0
U159	1.2V Voltage regulator	Provides power to DDR4 Channel 0
U165	2.5V Voltage regulator	Provides power to DDR4 Channel 1
U166	0.6V Voltage regulator	Provides power to DDR4 VTT Channel 1
U157	1.2V Voltage regulator	Provides power to DDR4 Channel 1
U192, U193	0.6V Precision voltage reference	Provides reference voltage to DDR4 Channel 0 and Channel 1
U136	Controlled power FET	Control power to all memory voltage regulators
U51	Power protector	Provides power protection to QSFP 1 (J16)
U52	Power protector	Provides power protection to QSFP 2 (J18)

A.2. Power, Thermal, and Mechanical Considerations

A.2.1. Power Guidelines

This section describes the power supply for Intel Stratix 10 DX FPGA Development Kit.

A laptop-style DC power supply is provided with the development kit. Use only the supplied power supply. The power supply has an auto-sensing input voltage of 100-240 V AC power and will output 12 V DC power at 20 A to the development board. The 12 V DC input power is then stepped down to various power rails used by the board components.

An on-board multi-channel analog-to-digital converter (ADC) measures both the voltage and current for several specific board rails. The power utilization is displayed on a graphical user interface (GUI) that can graph power consumption versus time.

The Intel Stratix 10 DX FPGA Development Kit has two modes of operation:

- **Standard PCIe compliant system**

In this mode, plug the board into an available PCI Express slot and connect the standard 2x4 power cords available from the PC's ATX power supply to J11 on the board. The PCIe slot together with the auxiliary PCIe power cords are required to power the entire board. If you do not connect the 2x4 auxiliary power connection, the board does not power on. The power switch SW3 is ignored when the board is used in the PCIe system.

Figure 32. Setup Example

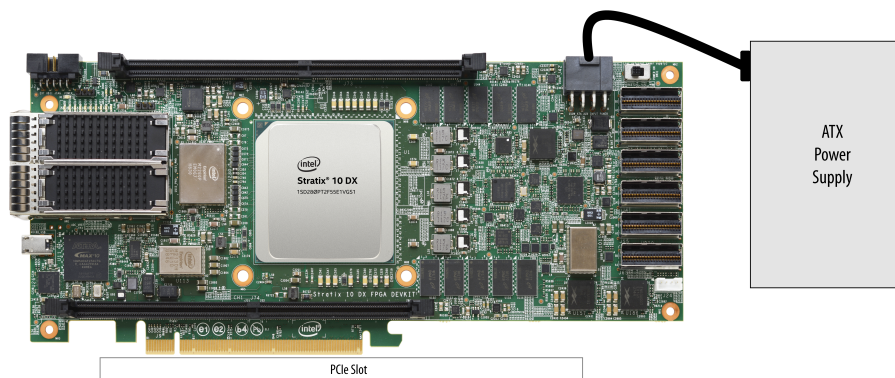

- **Standalone evaluation board** powered by included power supply
In this mode, plug the included power supply into the 2x4 pin connector (J42) and the AC power cord of the power supply into a power outlet. This power supply provides the entire power to the board without the need to obtain power from the PCIe slot. The power switch SW31 controls powering of the board.

Figure 33. Setup Example

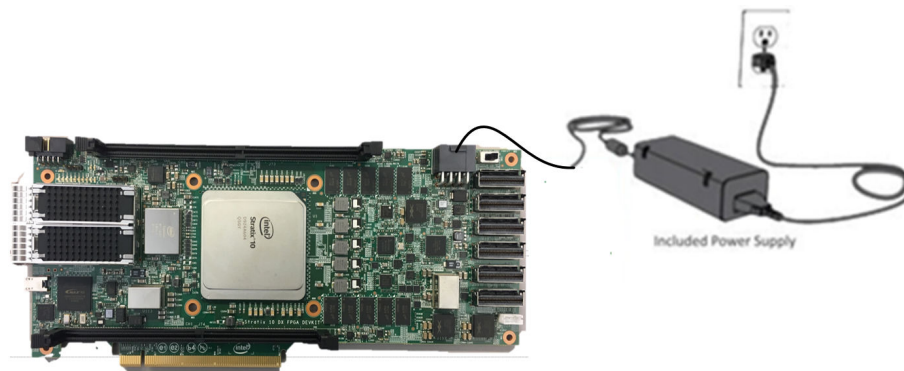

Table 9. Power Supply List

Source Name	Power Name	Maximum Output Current (A)	Description
ED8401(U47)	VCC	160	Core logic power
	VCCP		Periphery power
EN2260 (U230) 0.9V	S10_VCCERAM	53	Embedded memory and digital transceiver power
	VCCPLLDIG_SDM		Digital PLL power for SDM
	S10_VCCFUSE_GXP		Fuse power for P-Tile
	S10_VCCRT_GXP		Analog power for high speed circuits P-Tile
	S10_VCCRT_GXE		Analog power for high speed circuits E-Tile
	S10_VCCRTPLL_GXE		PLL power for E-Tile
EN2130H (U113) 1.8V	S10_VCCPLL_SDM	18	SDM PLL power
	S10_VCCADC		ADC power
	S10_VCCA_PLL		Analog power for PLL
	S10_VCCPT		
	S10_VCCBAT		
EN63A0 (U186) 1.8V	S10_VCCH_GXP	12	Analog power for P-Tile
	S10_VCCCLK_GXP		Clock power for P-Tile
EN63A0 (U184) 1.1V	S10_VCCH_GXE	8	Analog power for E-Tile
EP53F8QI (U78) 2.5V	S10_VCCCLK_GXE	1.5	Clock power for E-Tile
	2.5V		2.5V for others on board
EP53F8QI (U76) 2.4V	S10_VCCFUSEWR_SDM	0.5	Fuse power for SDM
EN6382QII (U188) 1.8V	S10_VCCIO	6	Power for IO banks of Intel Stratix 10
EZ6303QI (U116) 1.2V	M10_VCC_1.2V	1	Core power for Intel MAX 10
	M10_VCCDPLL		PLL power for Intel MAX 10
EZ6303QI (U116) 2.5V	M10_VCCA/VCC_ADC	0.2	Power for Intel MAX 10 ADC circuits
FP53F8QI (U79) 1.8V	M10_VCCIO	1	Power for 1.8V IOs of Intel MAX 10
EM2130H(U101) 3.3V	3.3V_REG_INST	30	System 3.3V rail
EV1320QI (U164) 0.6V	0p6V_DDR4_VTT_CH00	0.02	Termination power for on-board DDR4
EP53F8QI (U163) 2.5V	2V5_DDR4_CH00	0.1	2.5V rail for DDR4
EN63A0 (U159) 1.2V	S10_1v2OUT_CH00	12	Memory IO power for Ch00
EV1320QI (U166) 0.6V	0p6V_DDR4_VTT_CH11	0.02	Termination power for on-board DDR4
EP53F8QI (U165) 2.5V	2V5_DDR4_CH11	0.1	2.5V rail for DDR4

continued...

Source Name	Power Name	Maximum Output Current (A)	Description
EN63A0 (U157) 1.2V	S10_1v2OUT_CH11	12	Memory IO power for Ch00
MAX16550 (U217) 12V	12V_AUX2_IN	20	12V rail from AUX Power connector
MAX16550 (U96) 12V	12V_PCIe_SLOT	5.5	12V rail from PCIe Edge Connector

A.2.1.2. Power Sequence

The Intel Stratix 10 DX FPGA device requires proper power up and power down sequences.

Table 10. Power Sequencing Groups

Group 1	Group 2	Group 3
V _{CCL} /V _{CC} (0.89) V _{CCERAM} (0.9) V _{CCPLLDIG_SDM} (0.9) V _{CCRT_GXP} (0.9) V _{CCRT_GXE} (0.9) V _{CCRTPLL_GXE} (0.9) V _{CCFUSE_GXP} (0.9)	V _{CCH_GXE} (1.1) V _{CCH_GXP} (1.8) V _{CCADC} (1.8) V _{CCPLL_SDM} (1.8) V _{CCAPLL} (1.8) V _{CCIO} (2.5) V _{CCIO} (1.8)	V _{CCIO} (1.2, 1.25, 1.35, 1.5, 1.8) V _{CCFUSEWR_SDM} (2.4) V _{CCN_SDM} (1.8) V _{CCIO3} (1.5, 1.8, 2.5, 3.0)

- Required power up sequence: **Group 1 > Group 2 > Group 3**
 - Required power down sequence: **Group 3 > Group 2 > Group 1**
 - I/O pins are tri-stated during power-up or down sequence when the proper power sequence is followed. I/O pins should not be driven externally during this time or excess I/O pin current can result.
 - Power supplies in each group can be ramped up in any order.
 - The total power supply ramp-down time must not exceed 100 ms.
 - Ramp-up the last power supply of Group 1 to 90% (0.72) before ramping up the Group 2 supplies. Ramp up the last power supply of Group 2 to 90% (1.62V) before ramping up the Group 3 supplies.
 - V_{CCBAT_SDM} can be powered up anytime.
 - To use CvP/autonomous hard IP, the total time must be within 10 ms, from the first power supply ramp-up to the last power supply ramp-up.
- Note:* The POR delay time in Intel Stratix 10 DX FPGA is always within 2ms.
- V_{CCL} and V_{CC} should be tied together at customer board.
 - V_{CCPLL_HPS} and V_{CCPLL_SDM} should be tied together at customer board.
 - V_{CCPLLDIG_SDM} and V_{CCERAM} should be tied together at customer board with a filter.
 - V_{CCADC} and V_{CCA} should be tied together at customer board with or without a filter.
 - V_{CCERT}, V_{CCERT_PLL} and V_{CCERAM} should be tied together at customer board with or without a filter and should ramp up together for better current control.
 - Noise mask specifications must be met.
 - Use of an LC Filter is proposed to enable sourcing V_{CCERT}, V_{CCERT_PLL} from V_{CCERAM}.

- V_{CCN_SDM} has to stay in Group 3. It cannot be moved to Group 2 or merged with any Group 2 regulator.
- V_{CCFUSE_GXP} is always connected to V_{CCERAM} on customer board. For only internal testing purposes, V_{CCFUSE_GXP} is connected to V_{CCR} .
- All power rails must ramp up monotonically.
- All power rails must ramp up to full rail in Tramp specified in the [Intel Stratix 10 Device Datasheet](#).
- Ensure $(V_{CCIO} - V_{CCPT})$ is less than 1.92 to avoid damage to the device
- Hot socket is not supported in Intel Stratix 10 DX FPGA.

Figure 35. Power Sequence Flow Diagram

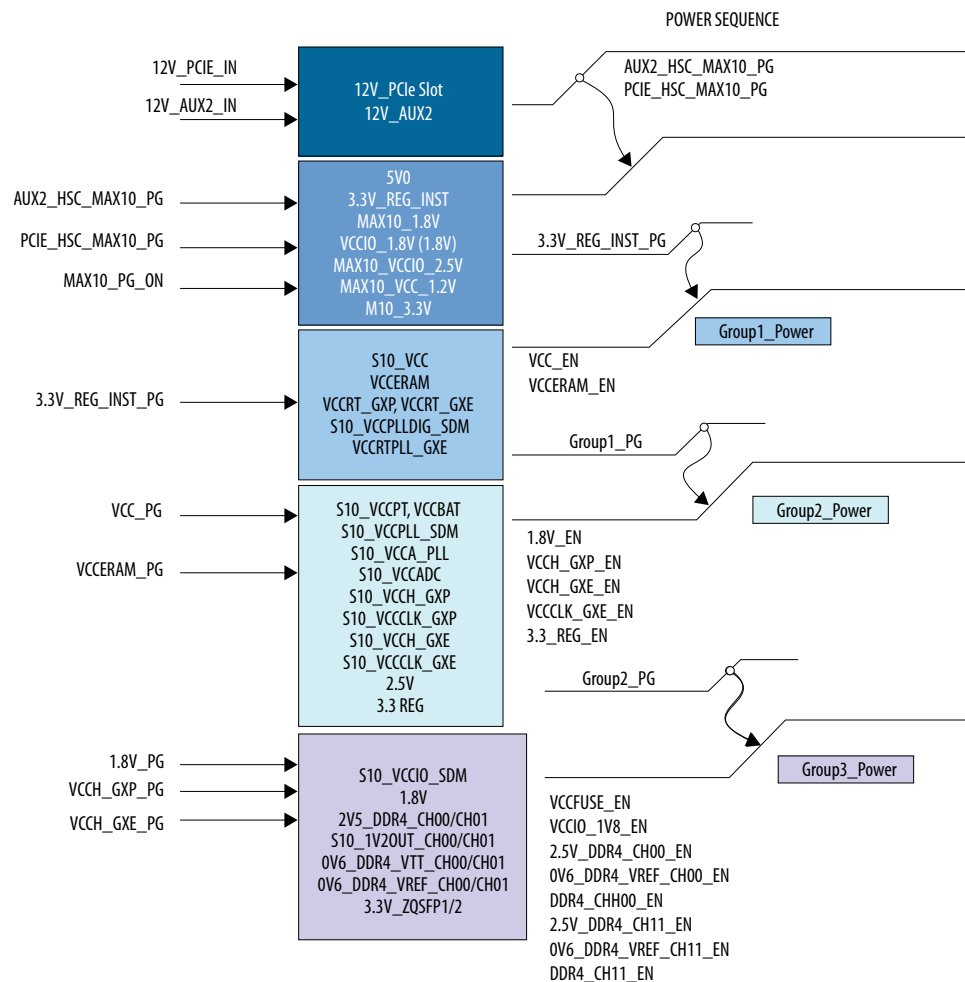

A.2.1.3. Power Measurement

Power measurements are provided for six FPGA power rails by using an ADC and sense resistors. The sense resistors are connected in series to the power regulator output. The I²C interface of the ADC or the regulators are used to sense the voltages. The I²C are connected to the Intel MAX 10 device for reading the voltage. The current

(A) reading is achieved by a PAC1931 (U233) reading the voltage drop across the sense resistor and software converts the voltage readings to current for each measured rail. The following power rails are monitored:

- VCC, VCCP (Power sensing by I²C on ED8401)
- 0.9V (Power sensing by I2C on EN2260, U230)
- 1.8V (Power sensing by I2C on EN2310, U113)
- 3.3V (Power sensing by I2C on EN2310, U101)
- VCCRT_GXE (Sense resistor R6685, monitoring via PAC1931, U233)
- VCCRT_GXP (Sense resistor R6688, monitoring via PAC1931, U233)
- 12V PCIe slot (Power sensing by I2C on MAX16550, U217)
- 12V AUX2 (Power sensing by I2C on MAX16550, U96)

A.2.2. Thermal Requirements

The thermal solution is an active cooling system designed to cool up to 250W total power of the board. The heatsink is designed to meet the height constraints of a 2-slot PCIe card form-factor as defined by the PCIe CEM specification revision 3.0.

The heatsink is securely mounted to the board using screws for easy assembly and removal. The thermal material used between FPGA and heatsink also ensures good thermal contact.

Figure 36. Air-cooled Heatsink Setup



A.2.2.1. Operating Conditions

The Intel Stratix 10 DX FPGA Development Kit is designed to operate within the following conditions while keeping the FPGA die temperature within its recommended operating T_j as defined in the Intel Stratix 10 DX FPGA data sheet (usually 100°C):

- Maximum power dissipation — 250 W
- Maximum ambient temperature — 0°C - 35°C
- FPGA Junction Temperature — 85°C

A.2.2.2. Temperature Monitoring

A temperature sensing device (MAX6581) monitors the temperature of the Intel Stratix 10 DX FPGA device. The Intel Stratix 10 DX FPGA device has seven die temperature diodes. The MAX6581 device senses these diodes and convert the signals to a digital form for the Intel MAX 10 device that can be read via a I²C bus.

Additionally, the OVERTEMP_n and ALERT_n signals from the MAX6581 allow Intel MAX 10 device to immediately sense a temperature fault condition. The Intel MAX 10 device controls the over temperature warning LED (D40, red-colored) to indicate an over temperature fault condition. Temperature fault set points can be programmed into the MAX6581 device.

Figure 37. MAX6581 Temperature Sensor Circuit

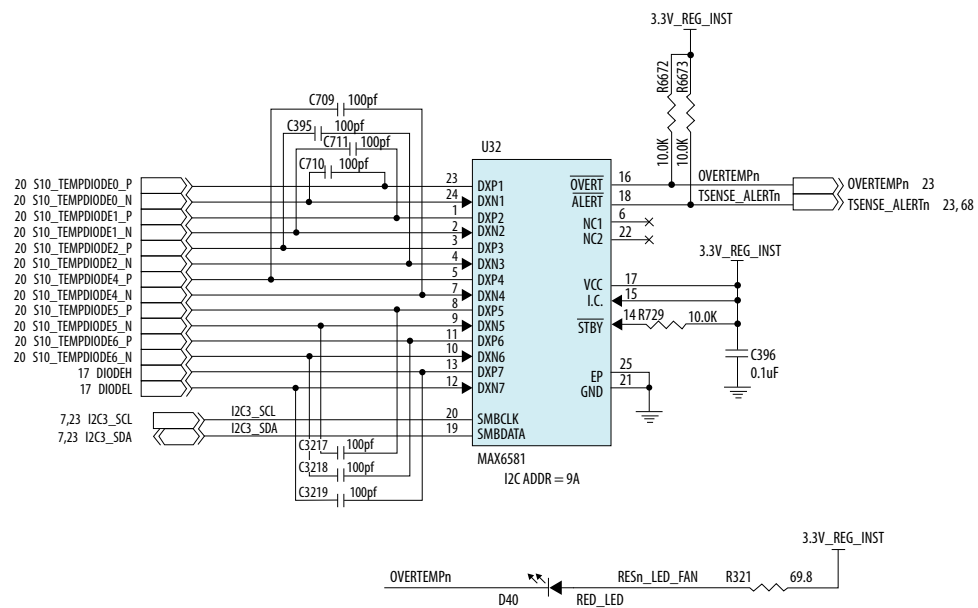

A.2.3. Mechanical Requirements

The Intel Stratix 10 DX FPGA Development Kit has a PCIe standard-height (4.376 in tall), 10.8" long, dual-slot (1.37 in high above the top surface of the PCB) form factor as defined by the PCIe CEM specification Revision 3.0. Additionally, this development kit includes the feature for retaining a high-mass card in the PCIe slot.

Figure 38. Sectional Profile

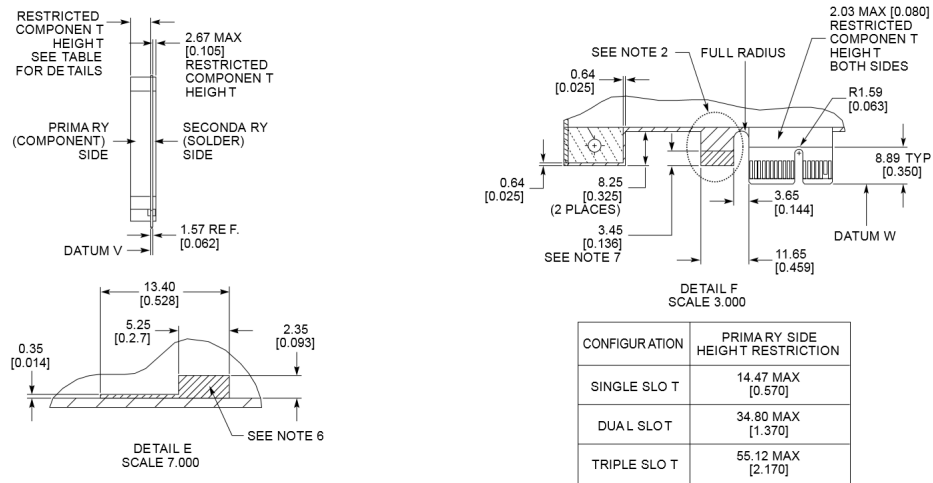
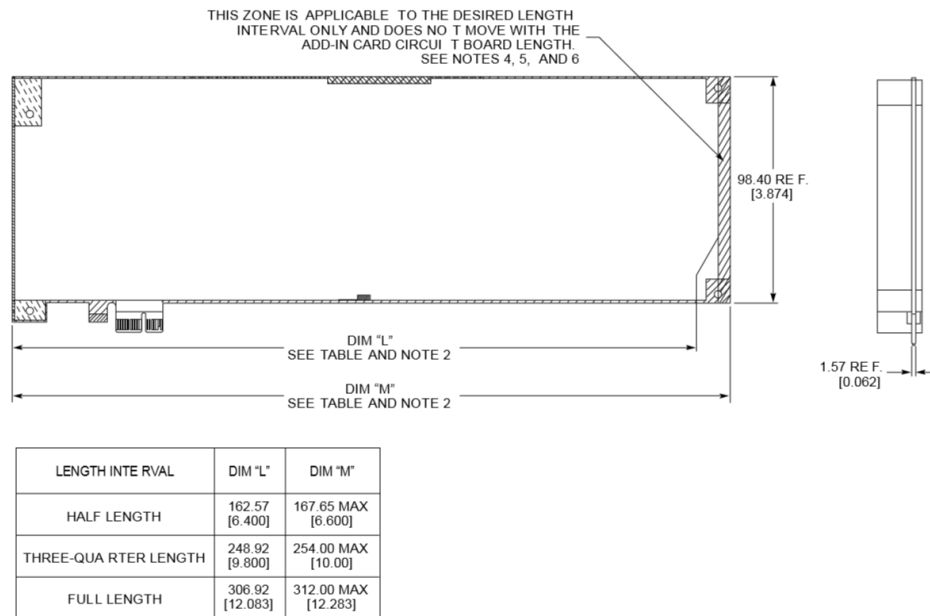

Figure 39. Top and Side Profile



A.3. Clock Circuits

All clocks are supplied by two on-board low-jitter programmable clock generator circuits. The following figure depicts the clock connection to the Intel Stratix 10 DX FPGA:

Figure 40. Clock Connection

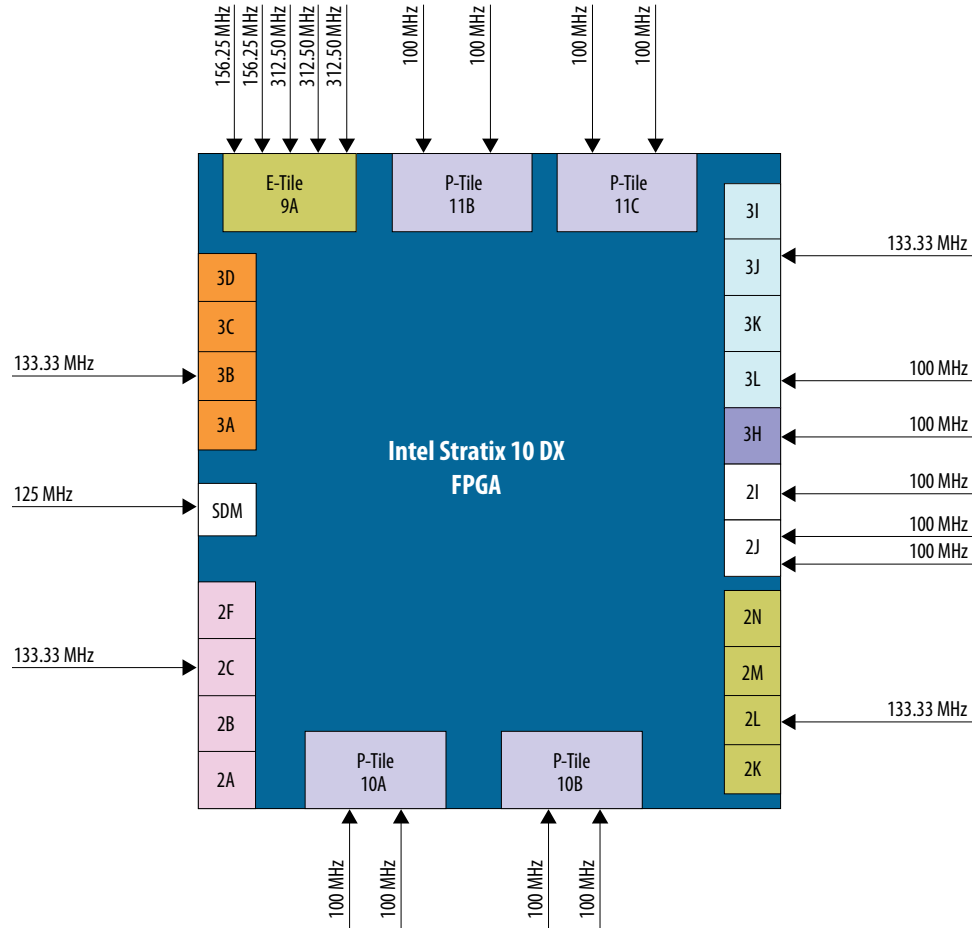

Table 11. On-board Oscillators

Signal Name	Frequency (MHz)	I/O Standard	Application
Source: U7 (Si5332A)			
CLK_100M_FPGA_3H_P	100	LVDS	FPGA Fabric Clock Bank 3H
CLK_100M_FPGA_3H_N		LVDS	
CLK_125M_LVC1_CONFIG	125	LVC MOS	FPGA Config Clock
CLK_133M_DDR4_0_P	133.33	LVDS	FPGA Fabric Clock Bank 3J
CLK_133M_DDR4_0_N		LVDS	
<i>continued...</i>			

Signal Name	Frequency (MHz)	I/O Standard	Application
CLK_133M_DDR4_1_P	133.33	LVDS	FPGA Fabric Clock Bank 2L
CLK_133M_DDR4_1_N		LVDS	
CLK_133M_DIMM_1_P	133.33	LVDS	FPGA Fabric Clock Bank 3B
CLK_133M_DIMM_1_N		LVDS	
CLK_133M_DIMM_0_P	133.33	LVDS	FPGA Fabric Clock Bank 2C
CLK_133M_DIMM_0_N		LVDS	
CLK_100M_FPGA_3L_0_P	100	LVDS	FPGA Fabric Clock Bank 3L
CLK_100M_FPGA_3L_0_N		LVDS	
CLK_100M_TEST_P	100	HCSL	Clock for bench test
CLK_100M_TEST_N		HCSL	
Source: U9 (Si5391A)			
CLk_156M.25M_QSFP1_P	156.25	LVPECL	Reference Clock for Transceivers 9A
CLk_156M.25M_QSFP1_N		LVPECL	
CLk_156M.25M_QSFP0_P	156.25	LVPECL	Reference Clock for Transceivers 9A
CLk_156.25M_QSFP0_N		LVPECL	
CLk_312M.50M_QSFP0_P	312.50	LVPECL	Reference Clock for Transceivers 9A
CLk_312M.50M_QSFP0_N		LVPECL	
CLk_312M.50M_QSFP1_P	312.50	LVPECL	Reference Clock for Transceivers 9A
CLk_312M.50M_QSFP1_N		LVPECL	
CLk_312M.50M_QSFP2_P	312.50	LVPECL	Reference Clock for Transceivers 9A
CLk_312M.50M_QSFP2_N		LVPECL	
CLK_100M_FPGA_2I_P	100	LVDS	FPGA Fabric Clock Bank 2I
CLK_100M_FPGA_2I_N		LVDS	
CLK_100M_FPGA_2J_1_P	100	LVDS	FPGA Fabric Clock Bank 2J
CLK_100M_FPGA_2J_1_N		LVDS	
CLK_100M_FPGA_2J_0_P	100	LVDS	FPGA Fabric Clock Bank 2J
CLK_100M_FPGA_2J_0_N		LVDS	
CLK_100M_Si5391_P	100	LVDS	Clock to U7 Input 2
CLK_100M_Si5391_N		LVDS	

The default clock frequencies are as listed in the table. All the clock frequencies can be changed by using the Clock GUI.

A.4. Memory Interface

The Intel Stratix 10 DX FPGA device supports four independent memory interfaces:

- Two independent on-board DDR4
- Two DIMM sockets for DDR4 or Intel Optane DC Persistent memory modules

Figure 41. Memory Interface

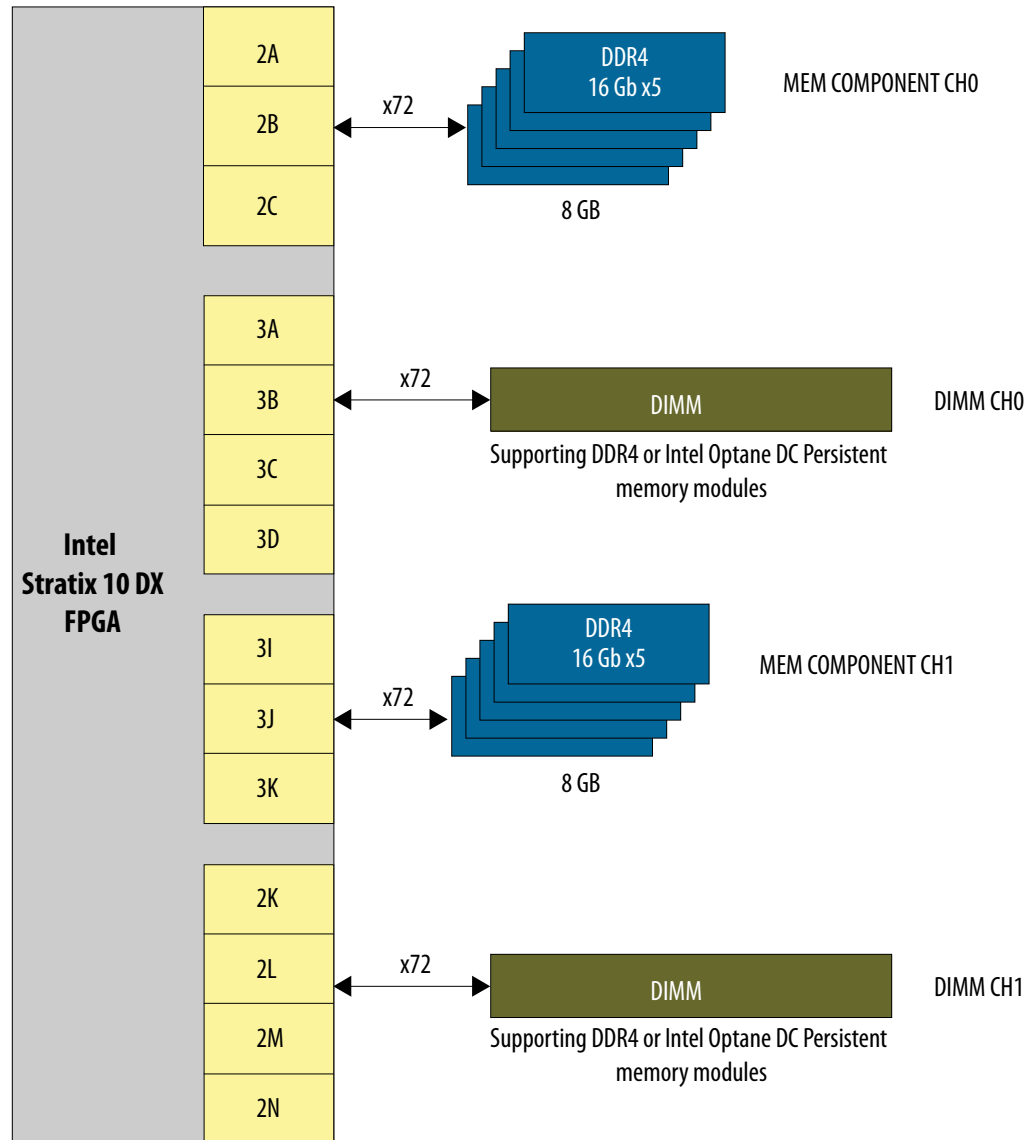

The on-board DDR4 uses five 16Gb DDR4 single rank devices connecting to bank 2K, 2L, 2M for memory component channel 1 and bank 3I, 3J, 3K for memory component channel 0. The total memory size of each channel is 8 GB running at 1200 MHz.

The 288-pin DIMM socket interfaces to bank 3I, 3J, 3K, 3L for DIMM channel 0 and to bank 2K, 2L, 2M, 2N for DIMM channel 1. This socket accepts DDR4 or Intel Optane DC Persistent memory module (requires Intel memory controller IP core). It supports dual rank at frequency 1067 MHz, 16 GB per channel. It also supports single rank at frequency 1200 MHz, 8 GB per channel.

A.5. PCIe Interface

The Intel Stratix 10 DX FPGA Development Kit supports four PCIe Gen4 x16 interfaces using the four P-Tile of the Intel Stratix 10 DX FPGA device.

- One P-Tile (10A) supports PCIe x16 connecting to the devkit's PCIe edge connector. This interface supports PCIe x1, x4, x8, and x16 PCIe End point.
- Three P-Tile (11B, 11C, 10B) each connecting to their corresponding SlimSAS connector can be used as UPI (x20) or PCIe x16 interface in Endpoint or Root Port mode.

The PCIe Edge Connector has PCIe Wake signal (pin B11) and PCIe Clock request (pin B12) routed to the GPIO of the Intel Stratix 10 FPGA device.

A.6. UPI Interface

The Intel Stratix 10 DX FPGA Development Kit supports three individual UPI interfaces. The UPI functionality is enabled by a combination of the appropriate P-Tile settings and UPI protocol IP core available in Intel Quartus Prime Pro Edition software (additional licensing and enablement may apply). Each interface consists of two SlimSAS connectors, one for transmit signals and one for receive signals. Each UPI interface provides node ID for the host CPU to identify. Node ID can be set by strapping resistors on the board.

The Slim SAS connectors also carry SMBus/I2C, clock, GPIO, and PCIe signals.

A.7. Transceiver Signals: PCIe and UPI Interface

Figure 42. PCIe X16 End point - PCIe Slot Interface

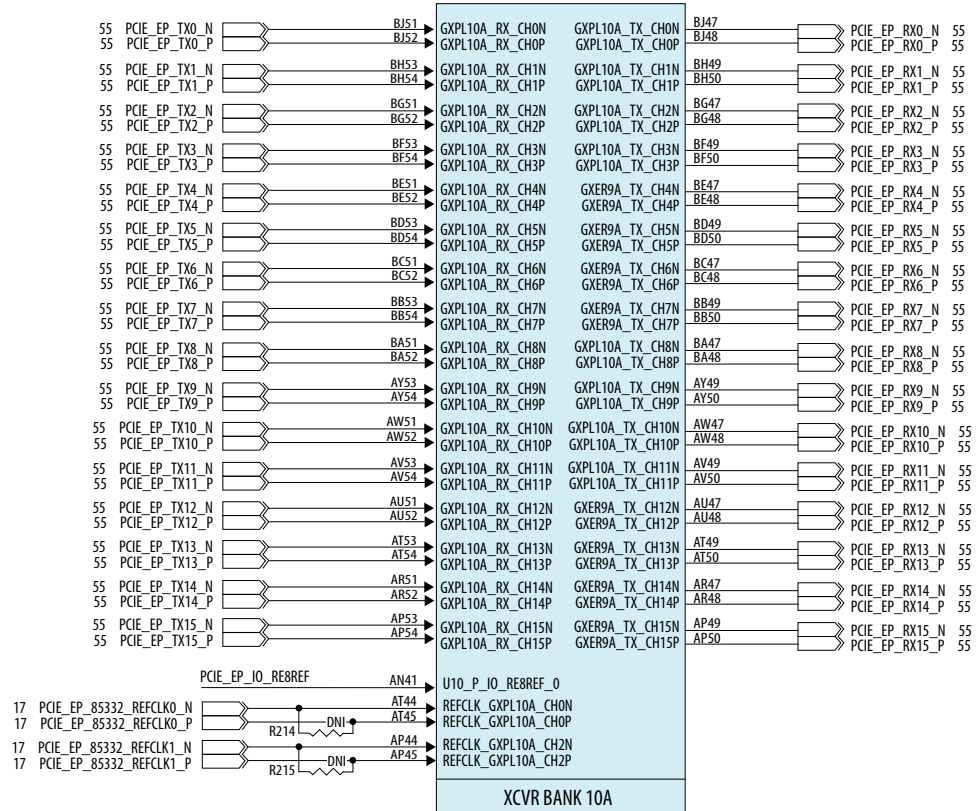

Figure 43. UPI 0 Link or PCIe Interface

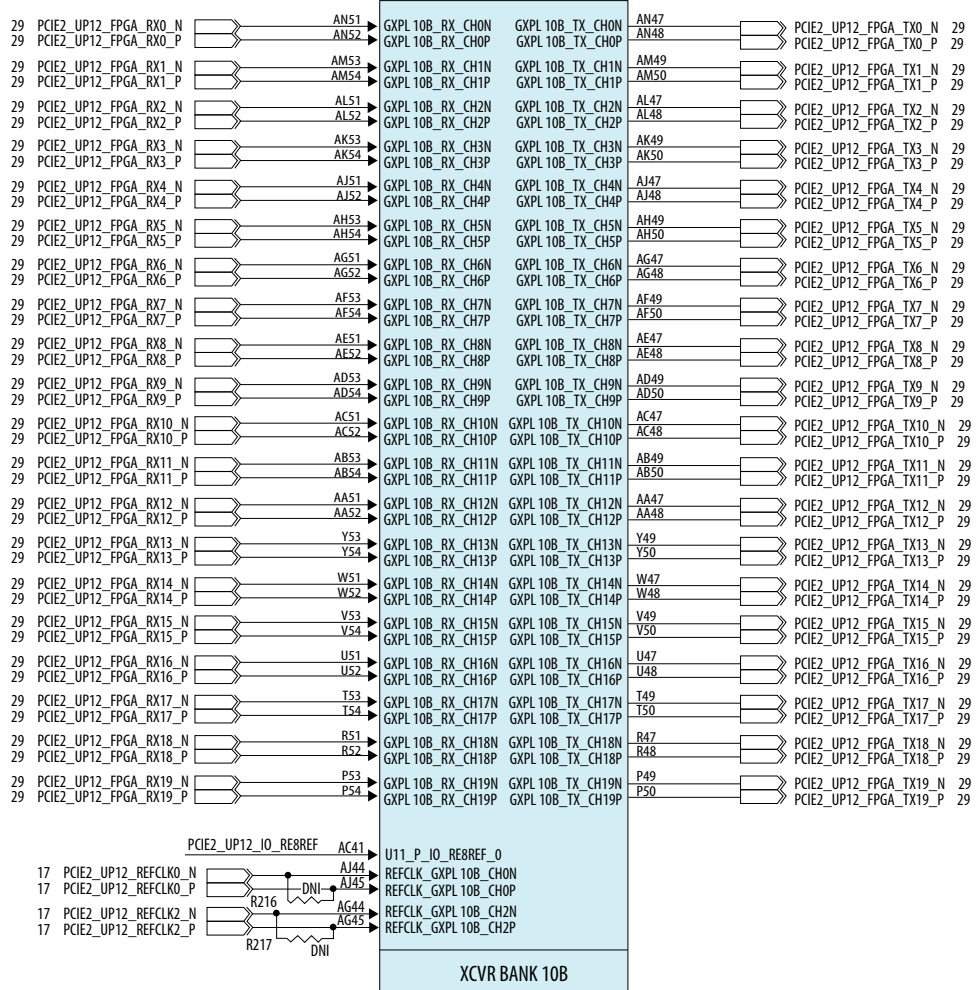

Figure 44. UPI 1 Link or PCIe Interface

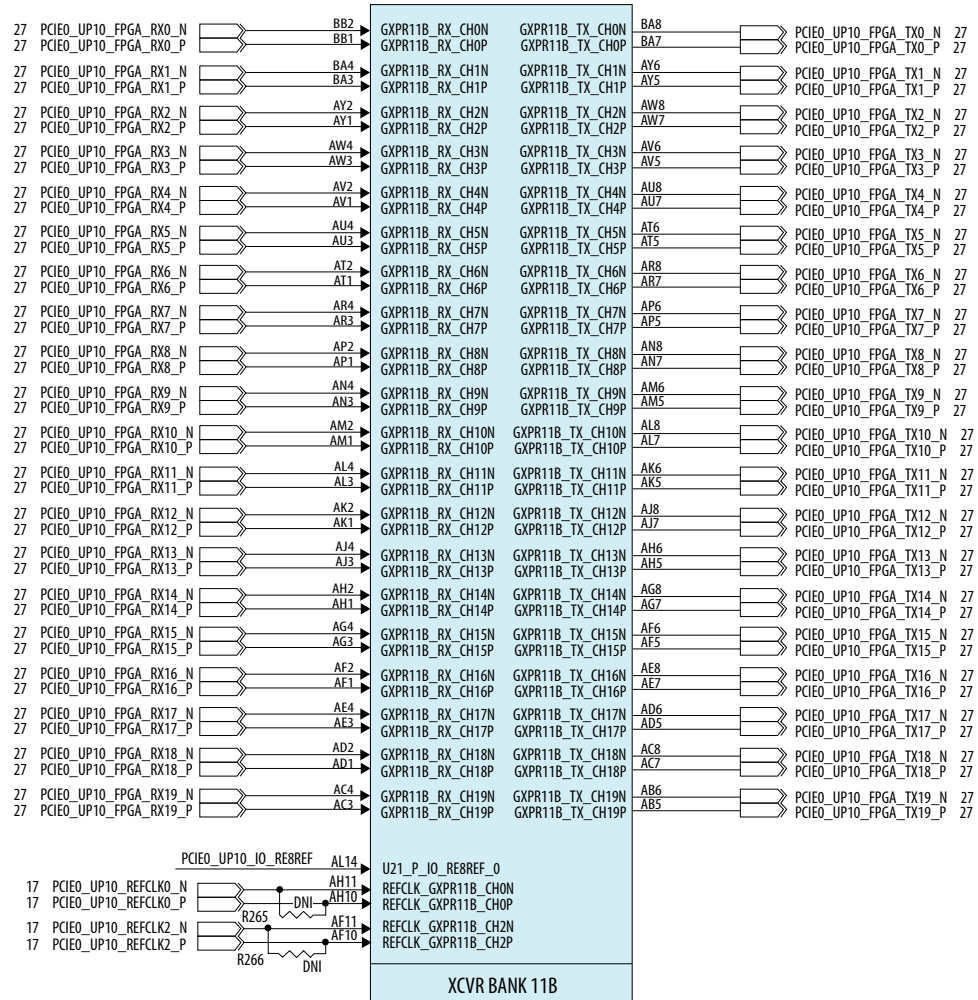
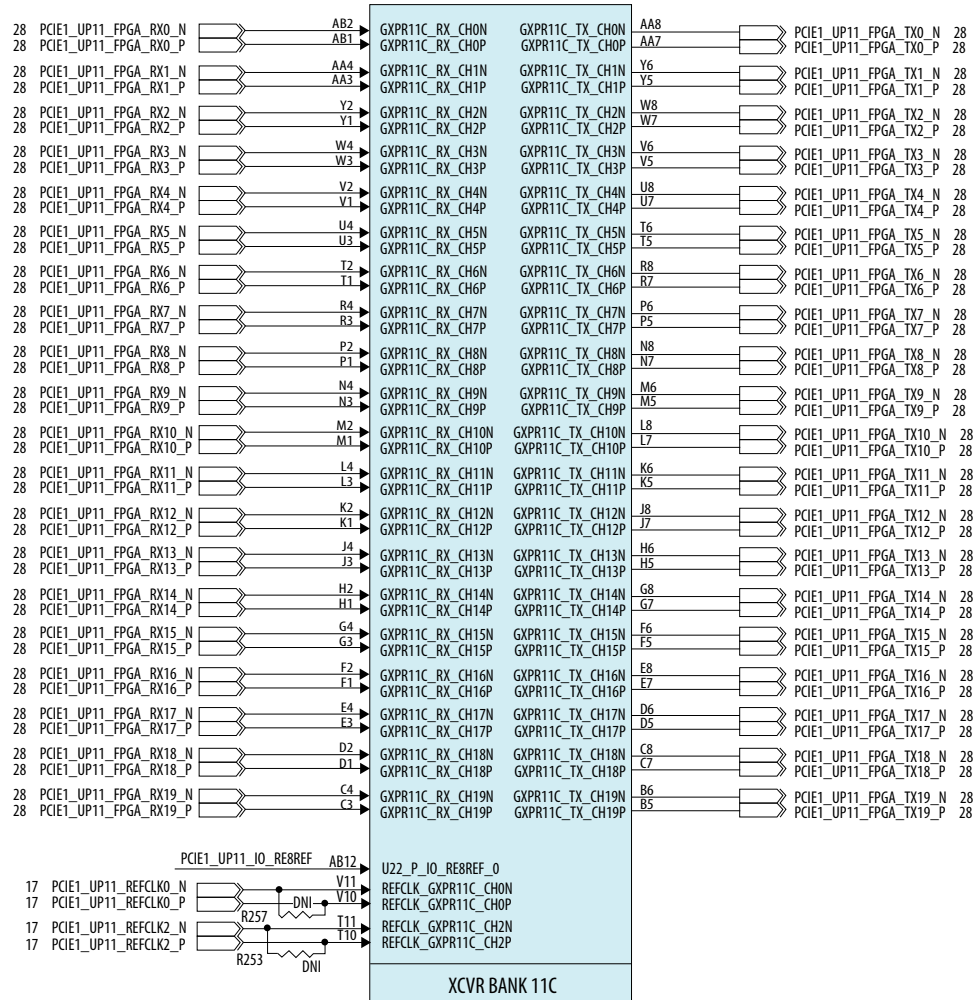

Figure 45. UPI 2 Link or PCIe Interface



A.8. SlimSAS Connector

Each PCIe or UPI interface connects to two slim SAS connectors, one for transmit signals and one for receive signals. Cables are used to connect the UPI or PCIe links from the devkit to the host board.

For UPI interface:

- UPI 0 Link, P-tile (10B) is routed to J55(FPGA-to-CPU) and J65(CPU-to-FPGA)
- UPI 1 Link, P-tile (11B) is routed to J38(FPGA-to-CPU) and J40(CPU-to-FPGA)
- UPI 2 Link, P-tile (11C) is routed to J39(FPGA-to-CPU) and J41(CPU-to-FPGA)

Figure 46. SlimSAS Connector Pinout

	A		B Latch Side	
	1	GND	GND	1
	2	TX_18_DN	TX_19_DN	2
	3	TX_18_DP	TX_19_DP	3
	4	GND	GND	4
	5	TX_16_DN	TX_17_DN	5
	6	TX_16_DP	TX_17_DP	6
	7	GND	GND	7
	8	TX_14_DN	TX_15_DN	8
	9	TX_14_DP	TX_15_DP	9
	10	GND	GND	10
	11	TX_12_DN	TX_13_DN	11
	12	TX_12_DP	TX_13_DP	12
	13	GND	GND	13
	14	TX_10_DN	TX_11_DN	14
	15	TX_10_DP	TX_11_DP	15
	16	GND	GND	16
	17	TX_8_DN	TX_9_DN	17
	18	TX_8_DP	TX_9_DP	18
	19	GND	GND	19
	20	TX_6_DN	TX_7_DN	20
	21	TX_6_DP	TX_7_DP	21
	22	GND	GND	22
	23	TX_4_DN	TX_5_DN	23
	24	TX_4_DP	TX_5_DP	24
	25	GND	GND	25
	26	TX_2_DN	TX_3_DN	26
	27	TX_2_DP	TX_3_DP	27
	28	GND	GND	28
	29	TX_0_DN	TX_1_DN	29
	30	TX_0_DP	TX_1_DP	30
	31	GND	GND	31
	32	TX_MISC_2	TX_MISC_6	32
	33	TX_MISC_1	TX_MISC_5	33
	34	GND	GND	34
	35	BCLK_OUT_DN	TX_MISC_4	35
	36	BCLK_OUT_DP	TX_MISC_3	36
	37	GND	GND	37

TX Fixed Connector Pinout

	A		B Latch Side	
	1	GND	GND	1
	2	RX_19_DN	RX_18_DN	2
	3	RX_19_DP	RX_18_DP	3
	4	GND	GND	4
	5	RX_17_DN	RX_16_DN	5
	6	RX_17_DP	RX_16_DP	6
	7	GND	GND	7
	8	RX_15_DN	RX_14_DN	8
	9	RX_15_DP	RX_14_DP	9
	10	GND	GND	10
	11	RX_13_DN	RX_12_DN	11
	12	RX_13_DP	RX_12_DP	12
	13	GND	GND	13
	14	RX_11_DN	RX_10_DN	14
	15	RX_11_DP	RX_10_DP	15
	16	GND	GND	16
	17	RX_9_DN	RX_8_DN	17
	18	RX_9_DP	RX_8_DP	18
	19	GND	GND	19
	20	RX_7_DN	RX_6_DN	20
	21	RX_7_DP	RX_6_DP	21
	22	GND	GND	22
	23	RX_5_DN	RX_4_DN	23
	24	RX_5_DP	RX_4_DP	24
	25	GND	GND	25
	26	RX_3_DN	RX_2_DN	26
	27	RX_3_DP	RX_2_DP	27
	28	GND	GND	28
	29	RX_1_DN	RX_0_DN	29
	30	RX_1_DP	RX_0_DP	30
	31	GND	GND	31
	32	RX_MISC_6	RX_MISC_2	32
	33	RX_MISC_5	RX_MISC_1	33
	34	GND	GND	34
	35	RX_MISC_4	BCLK_IN_DN	35
	36	RX_MISC_3	BCLK_IN_DP	36
	37	GND	GND	37

RX Fixed Connector Pinout

A.9. QSFP Network Interface

The Intel Stratix 10 DX FPGA Development Kit supports two QSFP28 connectors each connecting to the E-Tile (9A) transceivers. Each port can operate at 2x50G or 4x25G. These two ports support ZQSFP56 SR Optical modules as well as 3M DAC electrical cables.

The FPC202 dual port controller (from Texas Instruments) serves as the low speed signal aggregator that makes up the Dual 100Gpbs Ethernet interfaces. The FPC202 aggregates all low speed and I2C signals across two ports and presents it as a single

management interface to the host. The current limiters TP2557 (from Texas Instruments) also limit the current, in case if there is a short in the DAC electrical cables or Optical modules.

Figure 47. Transceiver QSFP-56 Two Ports of 25GbE

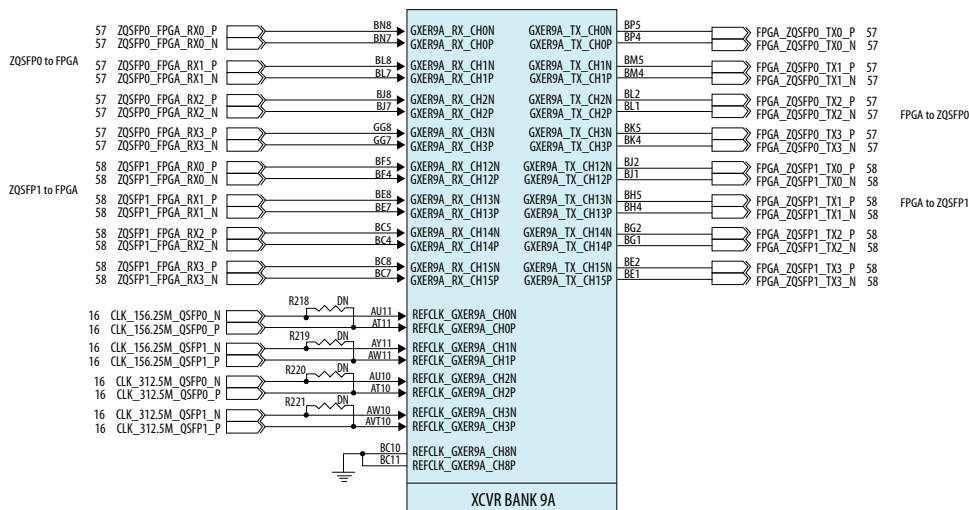

The E-tile (9A) of the Intel Stratix 10 DX FPGA provides eight transceiver channels, channel 0-3 are routed to QSFP0 and channel 12-15 are routed to QSFP1. The transceiver bank requires 156.25 MHz clocks for 28 Gbps NRZ and 325.50 MHz clocks for 56 Gbps PAM4. These clocks must have RPM jitter < 250 fs.

Figure 48. QSFP Connector

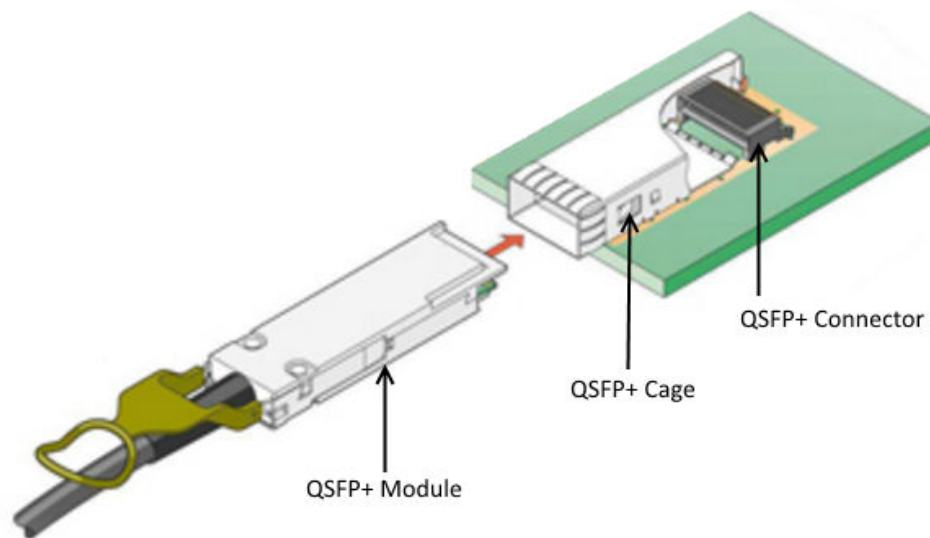

A.9.1. Dual Port Controller

The FPC202 dual port controller (from Texas Instruments) serves as the low speed signal aggregator for the two QSFP ports.

Table 12. I²C Device Address

Type	Bus	Address	Device
Intel Stratix 10 / Intel MAX 10 I ² C Address	I2C1	0x31	EM2140 (U230)
		0x44	EM2130 (U101)
		0x47	EM2130 (U113)
	I2C2	0xD8/0x6C	97ML1252E (U117)
		0x6A	Si5332A (U7)
		0x74	Si5391A (U9)
		0x4E/0x27	PCA9534 (U232)
		0x57	M24128 (U94)
		0x02	QSFP1 (U50)
		0x1E	QSFP2 (U50)
	I2C3	0x4D/0x9A	MAX6581 (U32)
PCIE_EP_3V3_I2C	TBD	PCIe End Point (J9)	

A.11. QSPI Flash Memory

A.11.1. Configuration QSPI Flash Memory

The Intel Stratix 10 DX FPGA Development Kit has one 2-Gbit QSPI flash device for non-volatile storage of the FPGA configuration data, board information, test application data and user code space.

The flash device is implemented to achieve a 4-bit wide data bus. Only Intel MAX 10 CPLD can access this flash device. The Intel MAX 10 CPLD accesses are for AVST x8 configuration of the FPGA at power-on and board reset events. It uses the Parallel Flash Loader (PFL) II IP core.

Table 13. Memory Map of the QSPI 2G Flash

Block	Access	Size	Address
Reserved	RW	17,920 KB	0x510.0000 - FFF.FFFF
Factory image	RW	81,920 KB	0x010.0000 - 50F.FFFF
PFL Option bits	RW	960 KB	0x001.0000 - 00F.FFFF
Reserved	RW	64 KB	0x000.0000 - 000.FFFF

A.11.2. NIOS QSPI Flash Memory

The Intel Stratix 10 DX FPGA development board has a 64 Mb QSPI flash for non-volatile storage of the NIOS application data, board information, test application data, and user code space.

The quad-serial flash provided has a ×4 data width, which can support an x1 access mode and ×4 access mode. This memory provides non-volatile storage for Board Test System Scratch, Board Information, and other information.

Table 14. NIOS QSPI Flash Memory Map

Block	Size (KB)	Address	Description
Board Test System Scratch	512	078.0000 - 07F.FFFF	BTS System Testing
Board Information	64	077.0000 - 077.FFFF	Board Information
Reserved	7616	000.0000 - 076.FFFF	Reserved
Total	8192	-	-

B. Safety and Regulatory Information

ENGINEERING EVALUATION KIT - THIS DEVICE IS INTENDED FOR EVALUATION ONLY! NOT FCC APPROVED FOR RESALE



This product has not been tested or approved by any agency or approval body for Electrical Safety, Electromagnetic Compatibility, Wired, or Wireless Telecommunications at the time of distribution.

Sales are limited to product developers, software developers, and system integrators; FCC NOTICE: This development kit is designed to allow:

- Product developers to evaluate electronic components, circuitry, or software associated with the kit to determine whether to incorporate such items in a finished product.
- Software developers to write software applications for use with the end product. This kit is not a finished product and when assembled, may not be resold or otherwise marketed unless all required.

FCC equipment authorizations are first obtained. Operation is subject to the condition that this product does not cause harmful interference to licensed radio stations and that this product does accept harmful interference. Unless the assembled kit is designed to operate under part 15, part 18, or part 95 of this chapter, the operator of the kit must operate under the authority of an FCC license holder or must secure an experimental authorization under FCC Part 5 of CFR Title 47.

Safety Certifications that may be required for installation and operation in your region have not been obtained.

B.1. Safety Warnings

Power Supply Hazardous Voltage

AC mains voltages are present within the power supply assembly. No user serviceable parts inside the power supply.



Power Connect and Disconnect

The AC power supply cord is the primary disconnect device from mains (AC power) and used to remove all DC power from the board/system. The socket outlet shall be installed near the equipment and shall be readily accessible.

System Grounding (Earthing)

To avoid shock, ensure that the power cord is connected to a properly wired and grounded receptacle. Ensure that any equipment to which this product is attached is also connected to properly wired and grounded receptacles.

	WARNING	
	RISK OF ELECTRIC SHOCK	
<p>Connect only to a properly earth grounded outlet. Apparaten skall anslutas till jordat uttag när den ansluts till ett nätverk.</p>		

Power Cord Requirements

The connector that plugs into the wall outlet must be a grounding-type male plug which is designed for use in your region. It must have certification marks showing certification by an agency in your region. The connector that plugs into the AC receptacle on the power supply must be an IEC 320, sheet C13, female connector. For more information, refer to the [website](#). If the power cord supplied with the system does not meet requirements for use in your region discard the cord, do not use with adapters.

	WARNING	
	RISK OF ELECTRIC SHOCK	
<p>Do not attempt to modify or use the supplied AC power cord if it is not the exact type and rating required.</p>		

Lightning or Electrical Storm

Do not connect or disconnect any cables or perform installation or maintenance of this product during an electrical storm.



Risk of Fire

To reduce the risk of fire, keep all flammable materials at a safe distance from the boards and power supply and configure the development product on a flame-retardant surface.

B.2. Safety Cautions

Thermal and Mechanical Injury

Certain components such as heat sinks, power regulators, and processors may be hot, heatsink fans are not guarded, and power supply fan may be accessible through guard. Care should be taken to avoid contact with these components.

	CAUTION	
	Hot Surfaces and Sharp Edges	
Integrated Circuits and heat sinks may be hot if the system has been running. Also, there might be sharp pins and edges on some boards. Contact should be avoided.		

Cooling Requirements

Maintain a minimum clearance area of 5 centimeters (2 inches) around the side, front, and back of the development product for cooling purposes; do not block power supply ventilation holes and fan.





Electro Magnetic Interference

This equipment has not been tested for compliance with emission limits of FCC and similar international regulations. Use of this equipment in a residential location is prohibited. This equipment generates, uses and can radiate radio frequency energy, which may result in harmful interference to radio communications. If this equipment does cause harmful interference to radio or television reception, which can be determined by turning the equipment on and off, take measures to eliminate the interference.

Telecommunications Port Restrictions

The wireline telecommunication ports (modem, xDSL, T1/E1) on this product must not be connected to the Public Switched Telecommunication Network (PSTN) as it might result in disruption of the network. No formal telecommunication certification to FCC, R&TTE Directive, or other national requirements has been obtained.

Electrostatic Discharge Warning

A properly grounded ESD wrist strap must be worn during operation/installation of the boards, connection of cables, or during installation or removal of daughter cards. Failure to do so can damage components within the system.

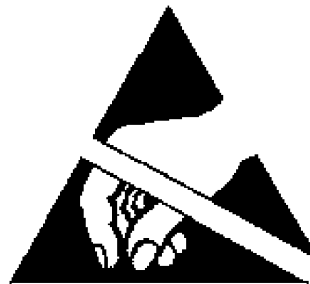

Please return this product to Intel for proper disposition. If it is not returned, refer to the local environmental regulations for proper recycling; do not dispose this product in any unsorted municipal waste.