

Features

- Fast response time
- Wide temperature range
- High surge current rating
- Low capacitance and insertion loss
- Stable performance throughout life
- Small surface mount package
- RoHS compliant*

Applications

- Set top boxes
- Industrial communications
- HVAC controls
- xDSL, POTS, G.Fast
- Antennae

GDT25 Series - Next-Generation 2-Electrode Gas Discharge Tube Arrestor

General Information

Bourns' new and improved next-generation surface mount 2-electrode GDT surge protection devices have been designed using Bourns' proprietary, advanced computer simulation techniques and offer industry-leading maximum impulse voltage limiting specifications in a small, environmentally rugged surface mount package. The performance delivered in the Bourns® GDT25 Series helps to significantly heighten protection against induced voltage transients such as lightning and AC induction. Plus, the enhanced level of protection with tighter voltage limiting provided during fast-rising events will reduce stress on downstream components compared to current GDT designs in the same application.

Product Characteristics

Storage Temperature Range -55 °C to +125 °C
 Operating Temperature Range -55 °C to +125 °C
 Climate Category (IEC 60068-1) 55 / 125 / 21
 Moisture Sensitivity Level (MSL) 1
 ESD Classification - HBM N/A

How to Order

GDT 2 5 - xx - S1 - RP

Description _____
 GDT = Gas Discharge Tube - Next-Generation Series

Electrodes _____
 2 = 2-Electrode

Size _____
 5 = 5 mm Diameter

Voltage _____
 07 = 75 V
 09 = 90 V
 35 = 350 V
 60 = 600 V

Package Designator _____
 S1 = 5 x 4.4 mm SMD (Standard)

Packaging Options _____
 RP = Reel Pack (Standard)
 Blank = Cut Tape
 BK = Bulk

BOURNS®

Asia-Pacific: Tel: +886-2 2562-4117 • Email: asiacus@bourns.com
EMEA: Tel: +36 88 885 877 • Email: eurocus@bourns.com
The Americas: Tel: +1-951 781-5500 • Email: americus@bourns.com
www.bourns.com



WARNING Cancer and Reproductive Harm - www.P65Warnings.ca.gov

*RoHS Directive 2015/863, Mar 31, 2015 and Annex.
 Specifications are subject to change without notice.

Users should verify actual device performance in their specific applications.

The products described herein and this document are subject to specific legal disclaimers as set forth on the last page of this document, and at www.bourns.com/docs/legal/disclaimer.pdf.

Additional Information

Click these links for more information:



Agency Recognition

Agency	Category	Agency File No.
UL	497B - 4th Edition	E153537

Circuit Diagram

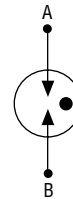

Note: Gas discharge tubes are bidirectional and non-polarized.

Typical Part Marking

Represents total content. Layout may vary.

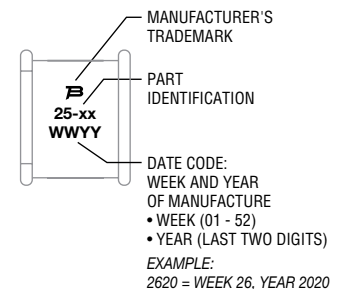

GDT25 Series - Next-Generation 2-Electrode Gas Discharge Tube Arrestor

BOURNS®

Electrical Characteristics

Test Methods per ITU-T K.12, IEEE C62.31 and IEC 61643-311 GDT standards.

Bourns Part No.	Device Specifications ⁽¹⁾								
	DC Sparkover Voltage $\pm 20\%$ (2) (3) (4)	Impulse Sparkover Voltage (2) (5)		Insulation Resistance (IR) (6)	Glow Voltage	Arc Voltage	Glow to Arc Transition Current	Capacitance	DC Holdover Voltage (8)
	100 V/s	100 V/ μ s	1 kV/ μ s	(7)	10 mA	> 1 A		1 MHz	< 150 ms
GDT25-07	75 V	350 V	600 V	> 2 G Ω	~ 70 V	~ 5 V	< 1 A	< 0.6 pF	52 V
GDT25-09	90 V	350 V	500 V						135 V
GDT25-35	350 V	650 V	800 V						
GDT25-60	600 V	1000 V	1100 V						

Bourns Part No.	Life Ratings ⁽⁹⁾					
	Max. Surge Current	Nominal Impulse Discharge Current			Nominal AC Discharge Current	
	8/20 μ s	8/20 μ s	10/350 μ s	10/1000 μ s	11 Cycles @ 60 Hz	1 Second
GDT25-07	10 kA 1 Operation	7 kA 10 Operations	1 kA 1 Operation	100 A 300 Operations	20 Arms 1 Operation	7 Arms 10 Operations
GDT25-09					25 Arms 1 Operation	
GDT25-35					20 Arms 1 Operation	
GDT25-60					25 Arms 1 Operation	

Notes:

- (1) At delivery AQL 0.65 Level II, DIN ISO 2859.
- (2) DC and Impulse Sparkover values are in ionized mode @ 25 °C.
- (3) Bourns recommends reflowing surface mount devices per *IPC/ JEDEC J-STD-020 rev. D*.
- (4) Surface mount GDTs may exhibit a temporary increase in the DC Sparkover Voltage after the solder reflow process. The DC Sparkover Voltage will recover within 24 hours. There is no quality defect nor change in protection levels during the temporary increase in DC Sparkover Voltage.
- (5) Impulse Sparkover voltage is expressed as a maximum value, with a 99 % probability of measured values within limit.
- (6) IR limits after Life Ratings > 100 M Ω .
- (7) IR Test Voltage: 50 V for GDT25-07 and GDT25-09, 100 V for GDT25-35 and GDT25-60.
- (8) Network applied (per *ITU-T K.12 Edition 9.0, Section 7*).
- (9) DC Sparkover Voltage limits after Life Ratings may exceed +20 % but will continue to protect without venting (per *ITU-T K.12 Edition 9.0, Section 6*, where applicable).

Specifications are subject to change without notice.

Users should verify actual device performance in their specific applications.

The products described herein and this document are subject to specific legal disclaimers as set forth on the last page of this document, and at www.bourns.com/docs/legal/disclaimer.pdf.

GDT25 Series - Next-Generation 2-Electrode Gas Discharge Tube Arrestor

BOURNS®

Product Dimensions

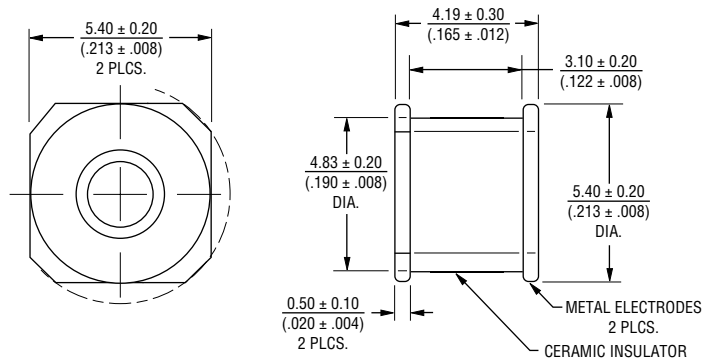

DIMENSIONS: $\frac{\text{MM}}{\text{(INCHES)}}$

Recommended Pad Layout

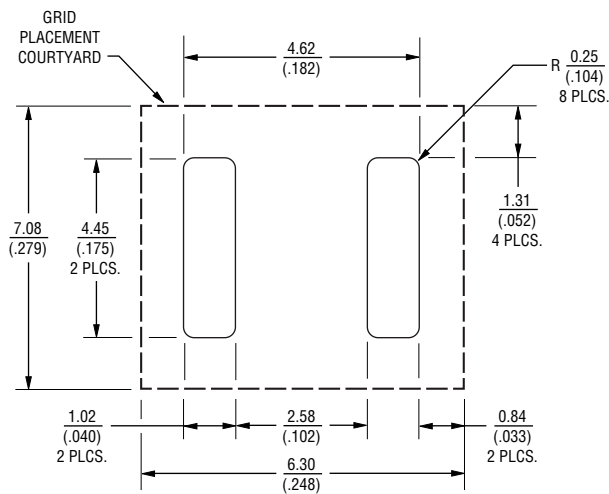

DIMENSIONS: $\frac{\text{MM}}{\text{(INCHES)}}$

Note: Recommended PCB land pattern in compliance with IPC-7351.

Specifications are subject to change without notice.

Users should verify actual device performance in their specific applications.

The products described herein and this document are subject to specific legal disclaimers as set forth on the last page of this document, and at www.bourns.com/docs/legal/disclaimer.pdf.

GDT25 Series - Next-Generation 2-Electrode Gas Discharge Tube Arrestor



Packaging Specifications

Model	Standard Packaging Quantity			
	Bulk (Bag)	Box	Reel	Cut Tape
GDT25				500
GDT25-BK	250	1000		
GDT25-RP			1500	

CUT TAPE

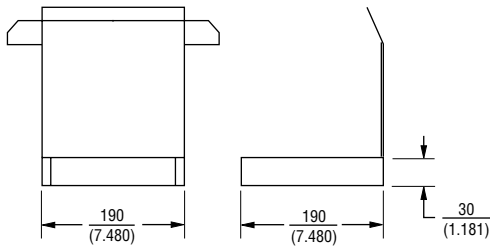

Contains 500 pieces in carrier tape within a carton box.

DIMENSIONS: $\frac{\text{MM}}{\text{(INCHES)}}$

REEL PACK

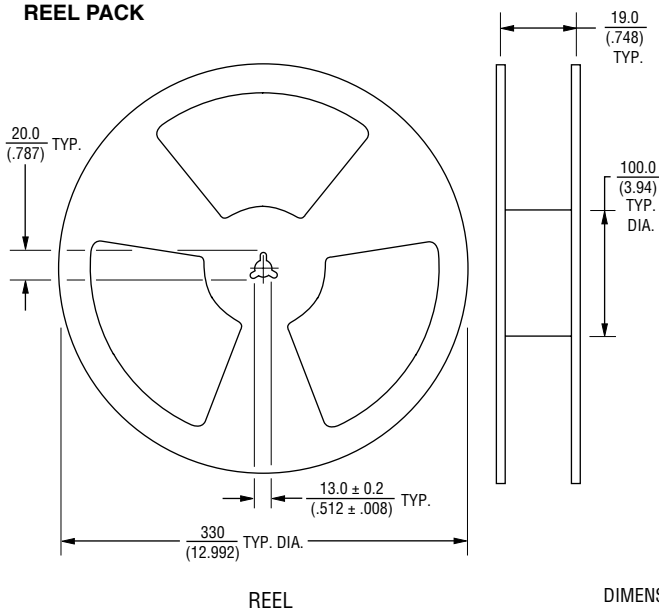

Reel is 330 mm in diameter and 19 mm wide.

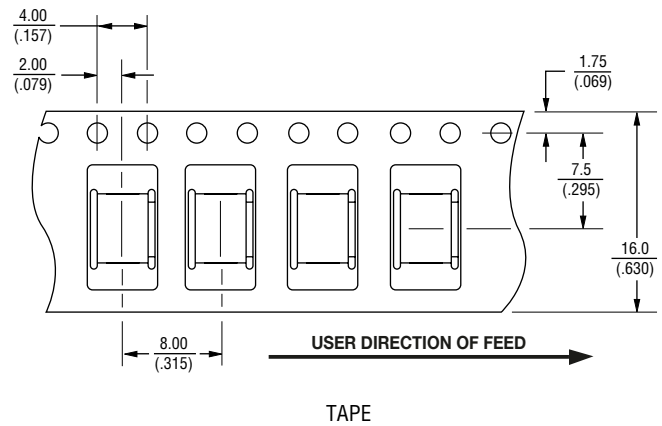

DIMENSIONS: $\frac{\text{MM}}{\text{(INCHES)}}$

TOLERANCES (EXCEPT WHERE NOTED): X.X $\frac{\pm 0.3}{(\pm .012)}$

X.XX $\frac{\pm 0.15}{(\pm .006)}$

DEGREES $\pm 1^\circ$

Specifications are subject to change without notice.

Users should verify actual device performance in their specific applications.

The products described herein and this document are subject to specific legal disclaimers as set forth on the last page of this document, and at www.bourns.com/docs/legal/disclaimer.pdf.

Soldering Parameters - Reflow Soldering

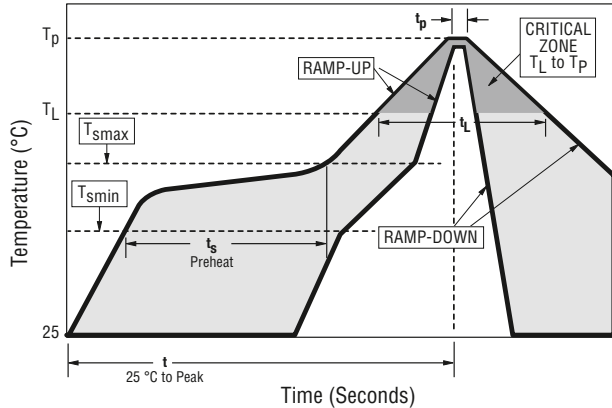

Notes:

Bourns recommends reflowing surface mount devices per *IPC/JEDEC J-STD-020 rev D*.

Surface mounted components (SMD) may exhibit a temporary increase in the DC Sparkover Voltage after the solder reflow process. The components should recover within 24 hours. There is no quality defect nor change in protection levels during the temporary change in DC Sparkover Voltage.

Reflow Condition		Pb-free Assembly
Preheat	Temperature Min. ($T_{S(min)}$)	150 °C
	Temperature Max. ($T_{S(max)}$)	200 °C
	Time (Min. to Max.) (T_S)	60 – 120 seconds
Average Ramp-up Rate (Liquidus Temperature (T_L) to Peak)		3 °C / second max.
$T_{S(max)}$ to T_L - Ramp-up Rate		5 °C / second max.
Reflow	Temperature (T_L) (Liquidus)	217 °C
	Temperature (T_L)	60 – 150 seconds
Peak Temperature (T_P)		260 +0/-5 °C
Time within 5 °C of Actual Peak Temperature (T_P)		10 – 30 seconds
Ramp-down rate		6 °C / second max.
Time from 25 °C to Peak Temperature (T_P)		8 minutes max.
Do not Exceed		260 ° C

Soldering Parameters - Hand Soldering

Solder Iron Temperature350 °C ± 5 °C
 Heating Time5 seconds max.